



Bauanleitung
Assembly instruction
Instructions de montage
Bouwhandleiding
Instrucciones de construcción

Manual de montagem
Istruzioni di montaggio
Инструкции по строительству
建筑说明



ADVANCED **Bagger/Digger**

	31057 2 x		172804 2 x		208241 5 x		208480 4 x
	32316 2 x		172805 2 x		208243 2 x		208481 7 x
	35414 2 x		203654 1 x		208244 3 x		208950 8 x
	35797 4 x		208228 1 x		208245 2 x		213384 6 x
	36819 6 x		208229 2 x		208317 1 x		213387 1 x
	36920 5 x		208231 2 x		208439 1 x		213388 5 x
	38237 2 x		208233 6 x		208443 1 x		213389 4 x
	38416 1 x		208234 6 x		208445 3 x		215109 1 x
	160544 2 x		208235 1 x		208446 2 x	  www.fischertechnik.de/FanClub	
	163204 4 x		208238 10 x		208449 1 x		
	172548 2 x		208240 1 x		208476 3 x		



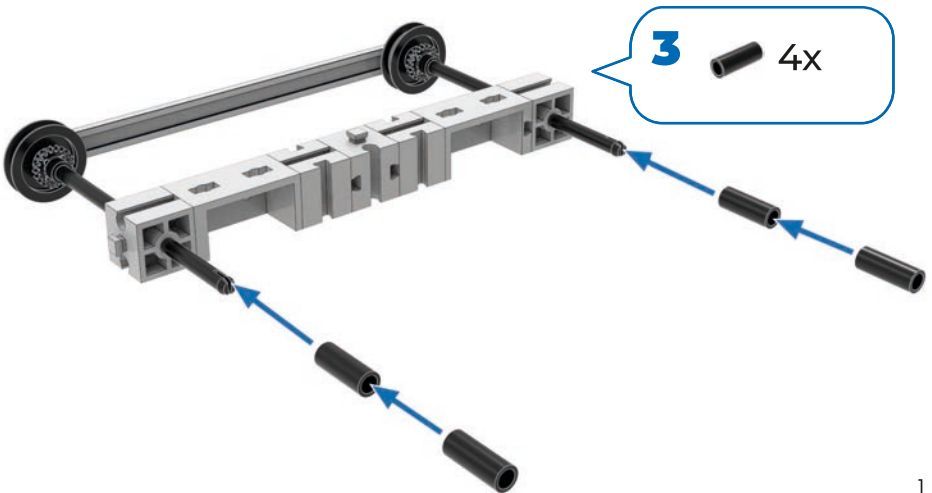
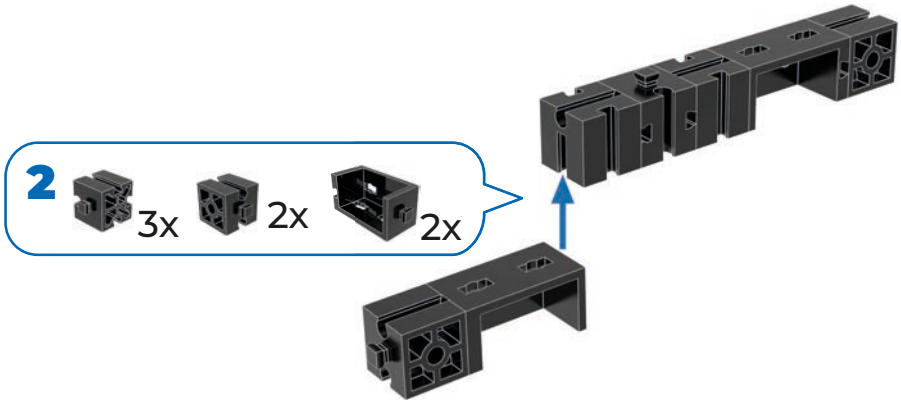
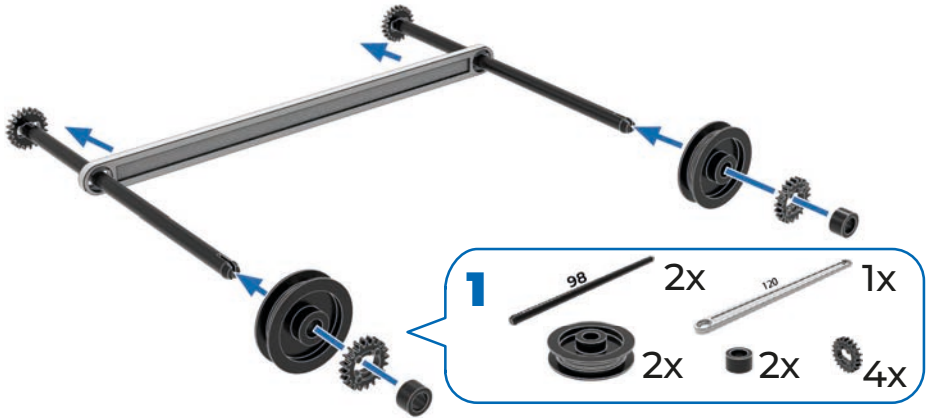

- Alle Einzelteile, insbesondere bewegliche Teile sind falls notwendig zu warten und zu reinigen.
- All components, especially moving parts, should be maintained and cleaned as necessary.
- Toutes les pièces détachées et en particulier les pièces mobiles, sont, si nécessaire, à entretenir et à nettoyer.
- Alle onderdelen, vooral de bewegende delen, kunnen, indien noodzakelijk, onderhouden en gereinigd worden.

- Es necesario mantener limpio y en buen estado cada una de las piezas. Particularmente las piezas móviles.
- Todas as peças individuais, especialmente peças móveis, devem ser submetidas à manutenção e limpas se necessário.
- Se necessario, tutti i singoli componenti, soprattutto le parti mobili, si devono eventualmente sottoporre a manutenzione e pulizia.
- Все детали, особенно подвижные, требуют ухода и чистки.
- 必要时应保养和清洁所有零件，尤指运动部件。

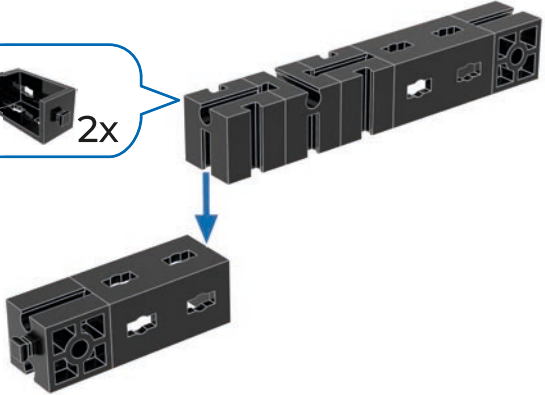

- 4**  3x  2x  2x



- 5**  1x  1x  2x
 2x  4x

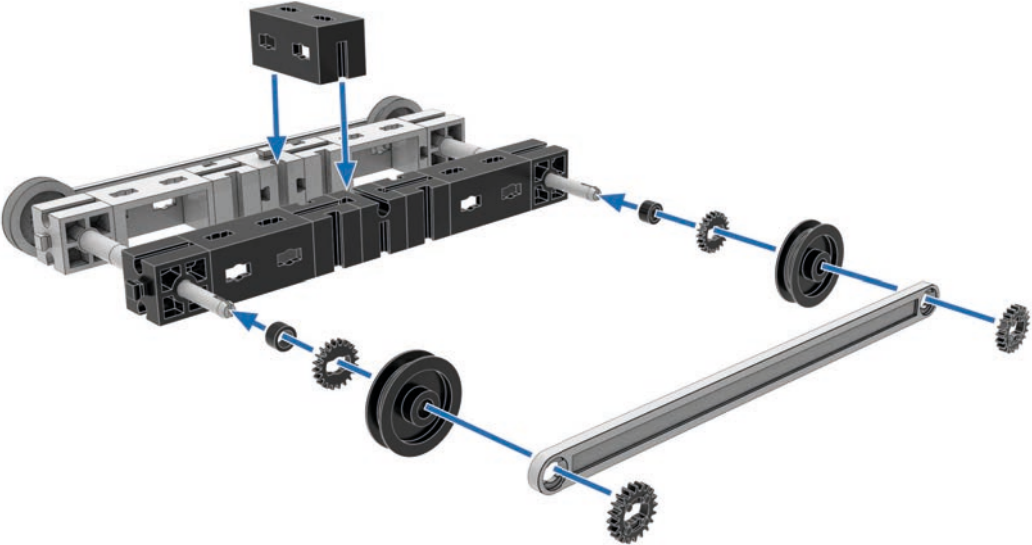

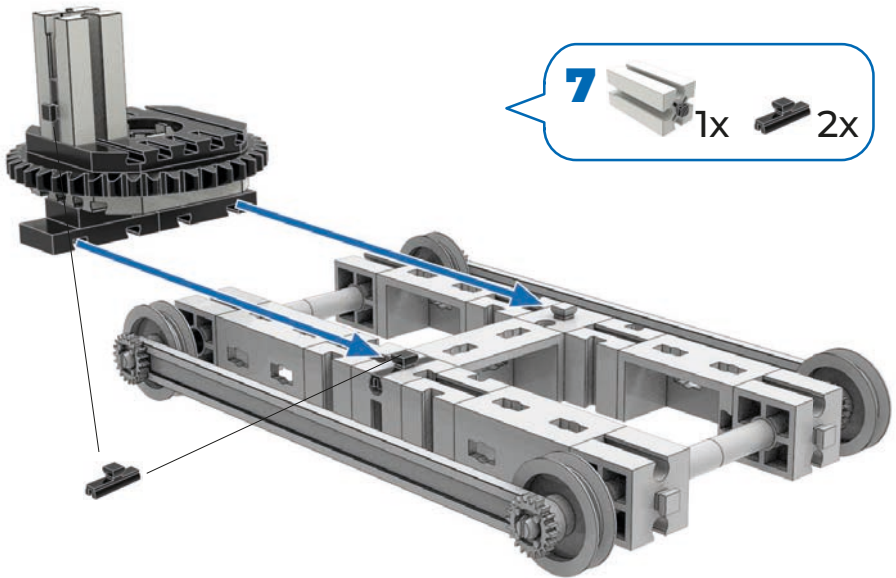
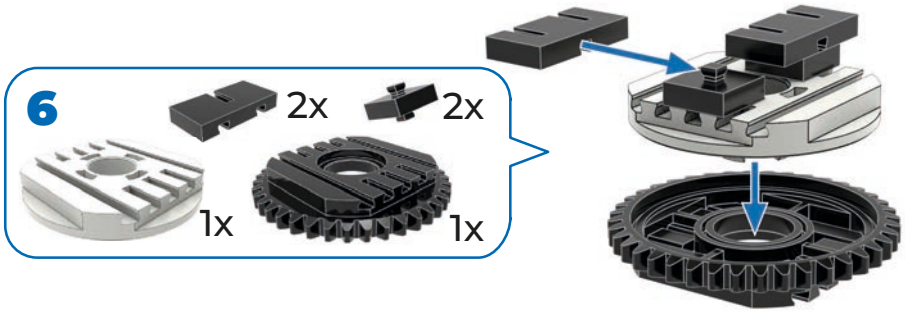

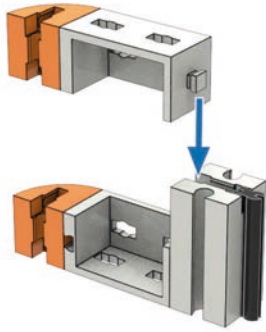

8

- 1x
- 2x
- 1x
- 2x

9

- 2x
- 2x
- 2x
- 2x

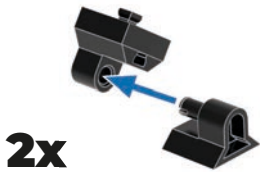
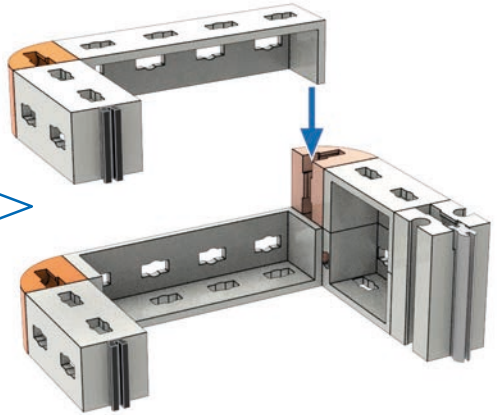

10

- 2x
- 2x
- 2x

11 1x 2x

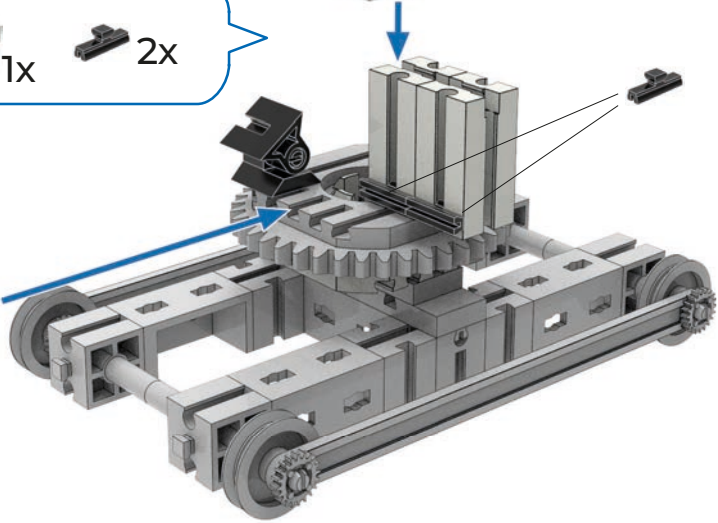

12 2x 2x

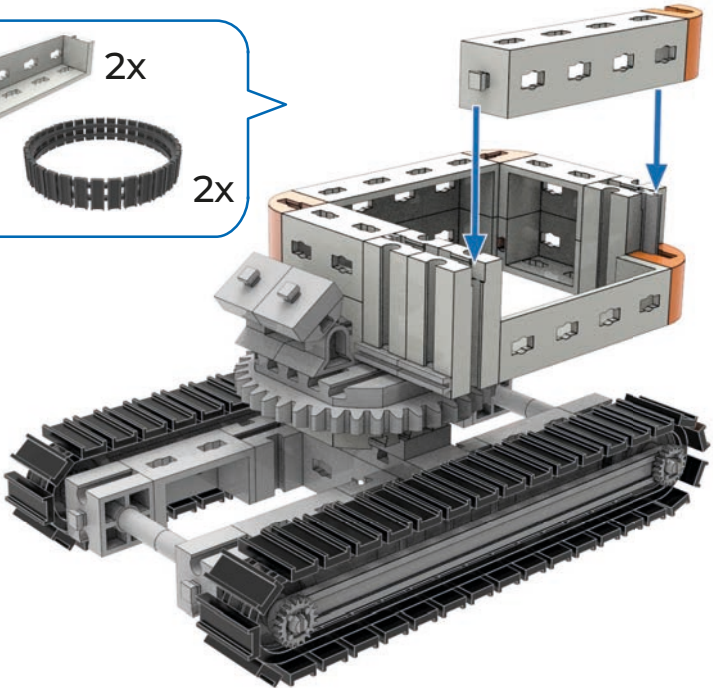

13

2x
1x
2x

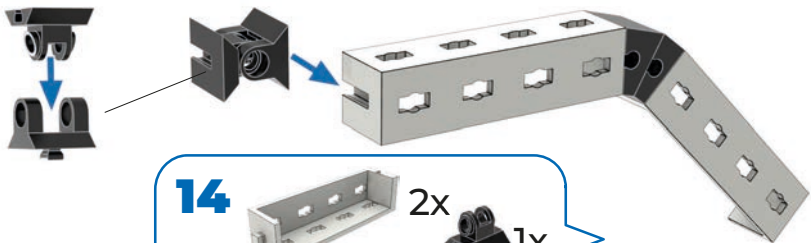
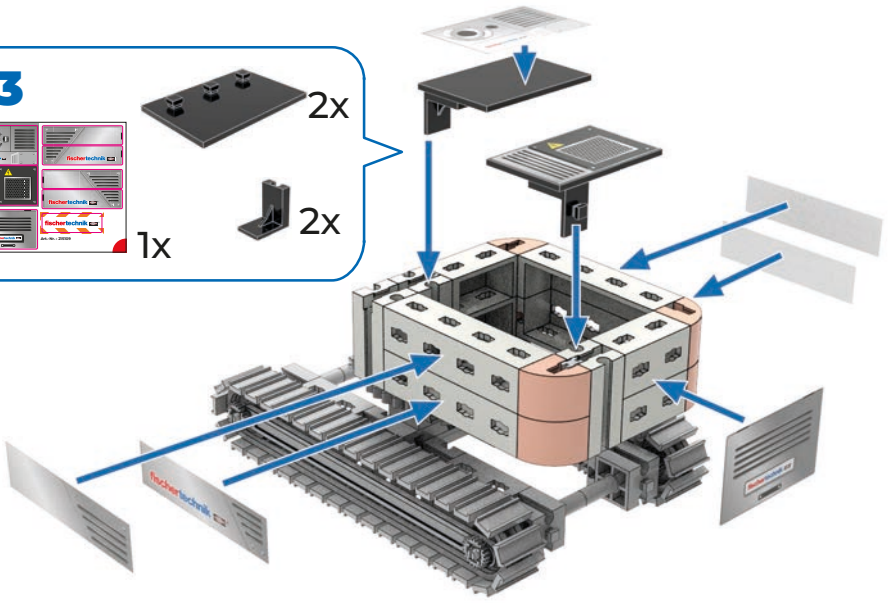





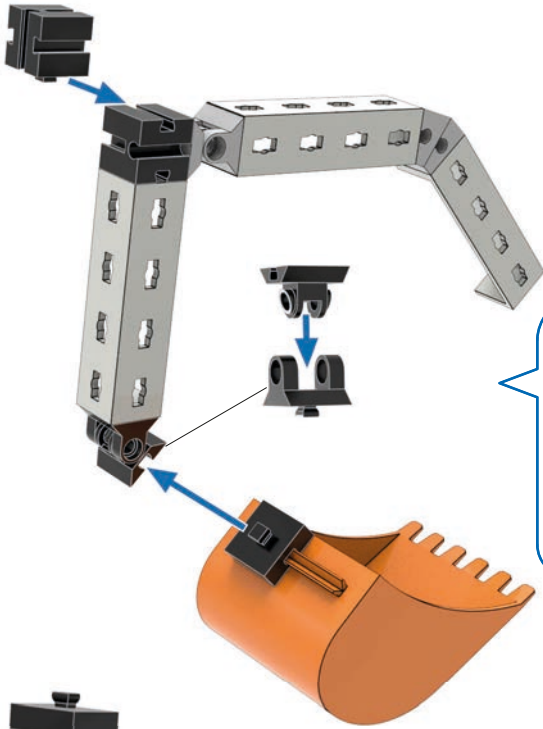

14

2x
30° 1x
15° 1x
1x 1x







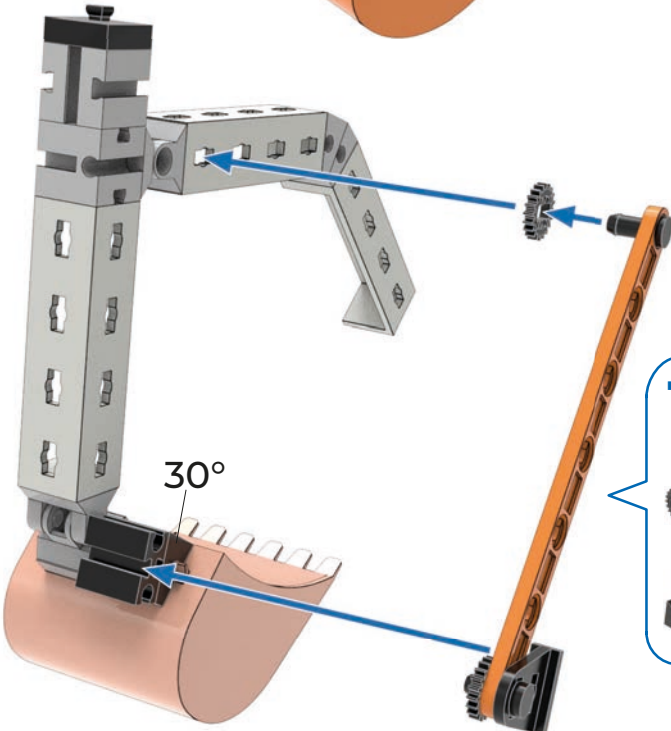

15

	2x		1x
	1x		1x
	1x		1x







16

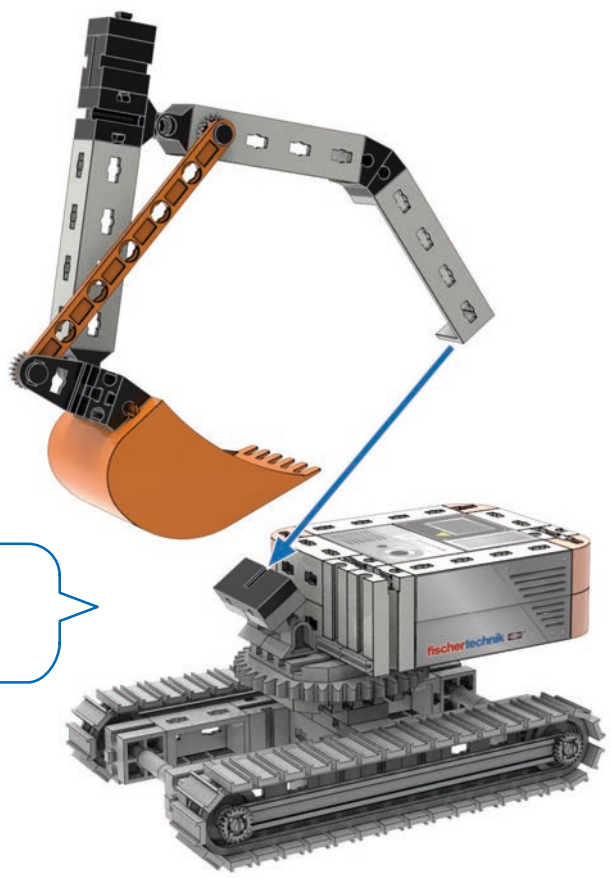



	90	1x				
	2x		2x		1x	
	30°	1x		1x		1x

17  1x

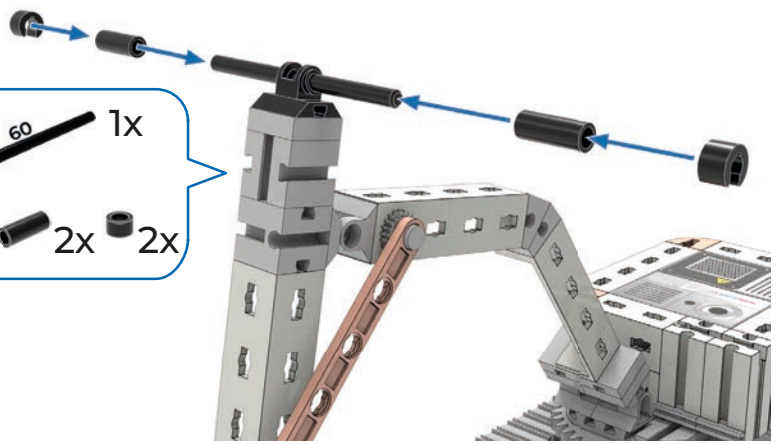



18  1x
 1x  2x  2x



- 19**
-  4x
 -  4x
 -  1x
 -  1x
 -  2x



- 20**
-  1x
 -  2x

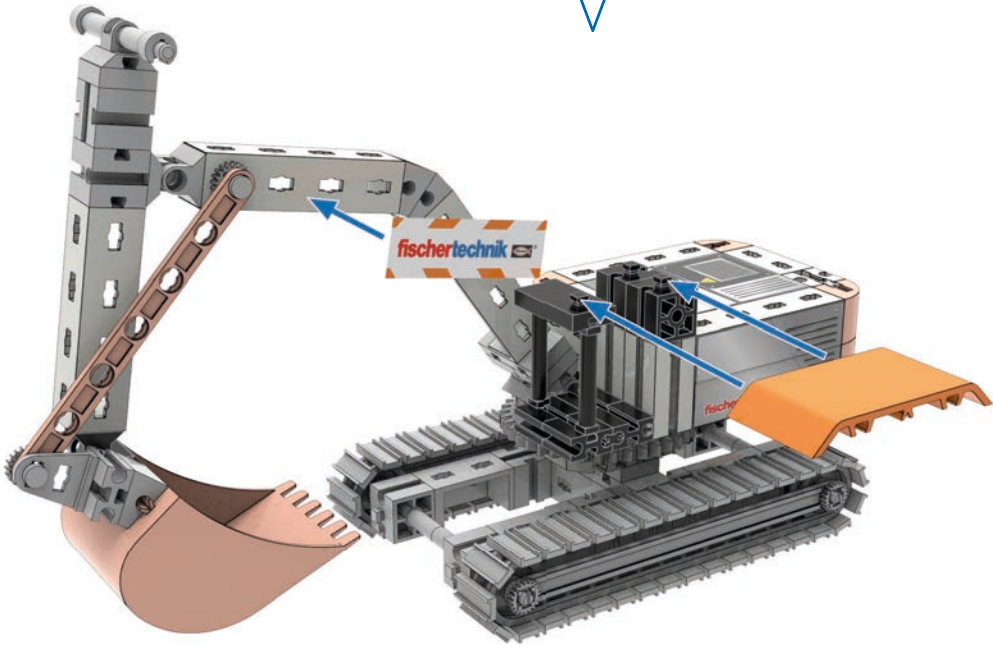

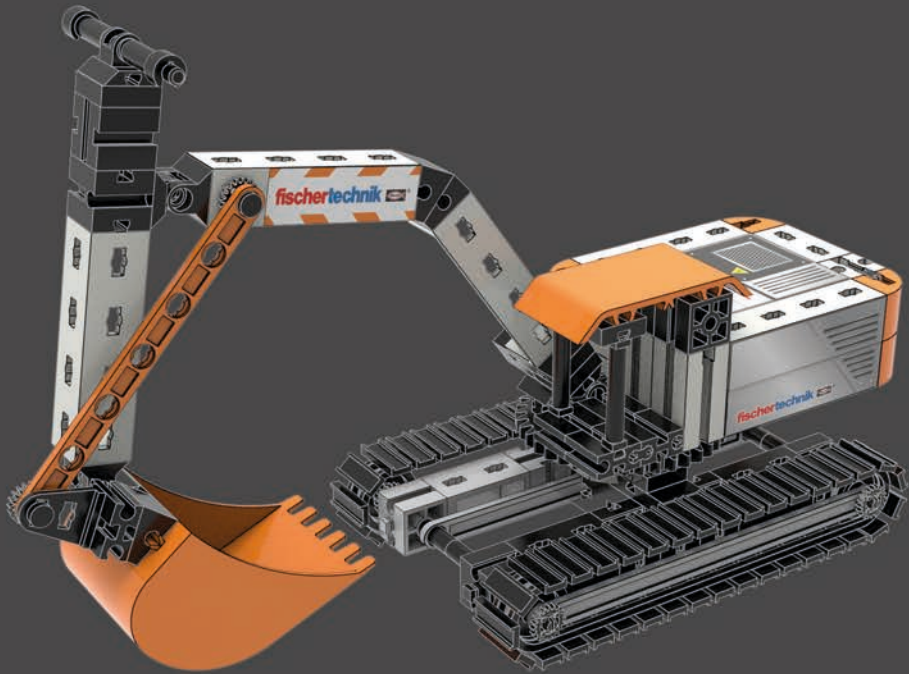

fischertechnik GmbH

Klaus-Fischer-Str. 1
72178 Waldachtal
Germany

Phone: +497443/12-4369

Fax: +497443/12-4591

Fax: +497443/12-4591

info@fischertechnik.de
www.fischertechnik.de

www.fischertechnik.de