

199582 - 06/23 - Co - Printed in Germany - Technische Änderungen vorbehalten - Subject to technical modifications

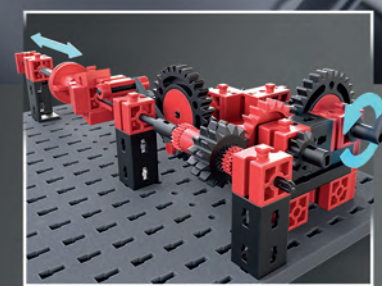
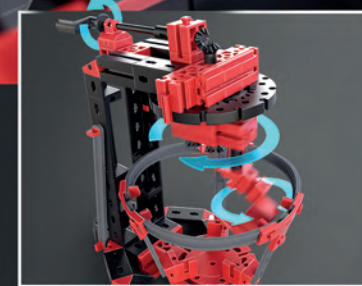
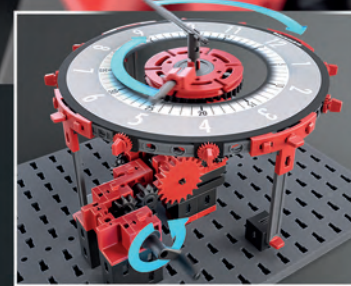

PROFI Mechanics

fischertechnik GmbH
Klaus-Fischer-Str. 1
72178 Waldachtal
Germany

Phone: +4974 43/12-43 69
Fax: +4974 43/12-45 91

info@fischertechnik.de
www.fischertechnik.de

Bauanleitung
Assembly instruction
Instructions de montage
Bouwhandleiding
Instrucciones de construcción

Manual de montagem
Istruzioni di montaggio
Инструкция по сборке
安装说明书

www.fischertechnik.de

PROFI Mechanics

MODELS

12

- Mit dem fischertechnik eLearning Portal geben wir dir die Möglichkeit, noch mehr Hintergrundwissen zum Thema des Baukastens zu erhalten. Über <https://www.fischertechnik.de/elearning-mechanics> gelangen Sie direkt zum eLearning Portal.
- The fischertechnik eLearning Portal provides even more background knowledge on the topic of the building set. You can access the portal directly at <https://www.fischertechnik.de/elearning-mechanics>
- Avec le portail e-learning fischertechnik, nous t'offrons la possibilité d'acquérir encore plus de connaissances de base au sujet du kit de construction. Tu peux accéder directement au portail via le lien <https://www.fischertechnik.de/elearning-mechanics>
- Met het fischertechnik eLearning portaal geven wij jou de mogelijkheid, nog meer achtergrondkennis over het thema van de bouwdoos te verkrijgen. Via <https://www.fischertechnik.de/elearning-mechanics> kom je rechtstreeks naar het portaal.
- Con el portal de eLearning de fischertechnik, te damos la posibilidad de obtener aún más conocimientos básicos sobre el tema del kit de montaje. Para acceder al portal, ingresa a <https://www.fischertechnik.de/elearning-mechanics>
- Com o portal de eLearning da fischertechnik damos lhe a possibilidade de obter ainda mais conhecimentos aprofundados sobre os kits de construção. Em <https://www.fischertechnik.de/elearning-mechanics> pode aceder diretamente ao portal de eLearning.
- Com o portal de aprendizagem virtual da fischertechnik, oferecemos a oportunidade de receber ainda mais informações contextuais sobre o tema kits de construção. Acesse o portal diretamente através do endereço <https://www.fischertechnik.de/elearning-mechanics>
- На обучающем интернет-портале компании fischertechnik вы получите еще больше базовых знаний по теме конструирования. Ссылка <https://www.fischertechnik.de/elearning-mechanics> ведет прямо на портал.
- 通过 fischertechnik 线上学习门户，我们让您能有机会了解更多有关该模块主题的背景知识。可通过 <https://www.fischertechnik.de/elearning-mechanics> 直接前往该门户。



- Werde Mitglied im kostenlosen fischertechnik Fan Club und nutze die Vorteile. Melde dich hierzu einfach unter www.fischertechnik.de/FanClub an.
- Become a member of the free fischertechnik fan club and take advantage of the benefits. Simply register at www.fischertechnik.de/FanClub
- Deviens membre du Fan club fischertechnik gratuit et profite de nombreux avantages. Il suffit de t'inscrire sur www.fischertechnik.de/FanClub.
- Word lid van de gratis fischertechnik Fan Club en maak gebruik van de voordelen. Meldt u hiervoor aan op www.fischertechnik.de/FanClub.
- Hazte miembro del club de aficionados gratuito de fischertechnik y disfruta de todas las ventajas. Regístrate en www.fischertechnik.de/FanClub.
- Torne-se um membro do fã-clube gratuito da Fischertechnik aproveite-a. Basta registrar-se em www.fischertechnik.de/FanClub.
- Diventa membro del fan club gratuito di fischertechnik e sfrutta tutti i vantaggi. Basta registrarsi a www.fischertechnik.de/FanClub.
- Стань членом бесплатного фан-клуба fischertechnik и пользуйся преимуществами. Для этого просто зарегистрируйся по адресу www.fischertechnik.de/FanClub.
- x免费加入慧鱼粉丝俱乐部 (fischertechnik Fan Club) 会员，即刻享受会员福利。只需前往 www.fischertechnik.de/FanClub 完成注册即可。

Inhalt
Contents
Contenu

Inhoud
Contenido
Conteúdo

Contenuto
Содержание
目录

Einzelteilübersicht / Spare parts list / Liste des pièces détachées / Onderdelenoverzicht / Lista de piezas / Resumo de peça individual /
Singoli componenti / Перечень деталей / 零件概览 1

Montagetips / Tips for assembly / Tuyaux pour le montage / Montagetips / Consejos para el montaje / "Dicas" para montagem /
Consigli per il montaggio / Советы по сборке / 装配建议 2

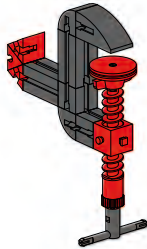

Headsethalter / Headset holder / Porte-casque / Hooftelefoonhouder /
Soporte para auriculares / Suporte de auscultadores / Supporto per cuffie /
Держатель гарнитуры / 耳机支架 3

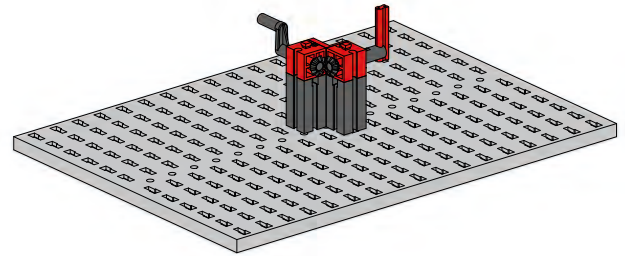

Winkelgetriebe / Angular gear / Réducteur d'angle / Hoekig tandwiel /
Engranaje angular / Engrenagem angular / Ingranaggio angolare /
Угловая передача / 角形齿轮 5

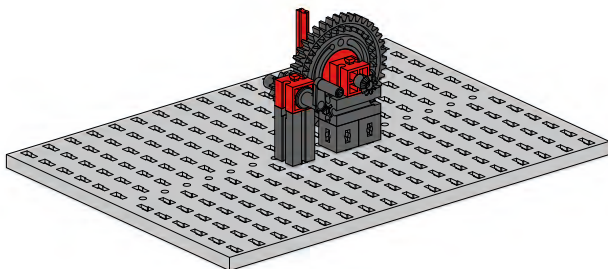

4:1 Stirnradgetriebe / 4:1 Spur gear / 4:1 Réducteur à engrenages cylindriques /
4:1 Tandwiel / 4:1 Engranaje recto / 4:1 Equipamento de esporão /
4:1 Ingranaggio cilindrico / 4:1 Прямозубая шестерня /
4:1 正齿轮 7

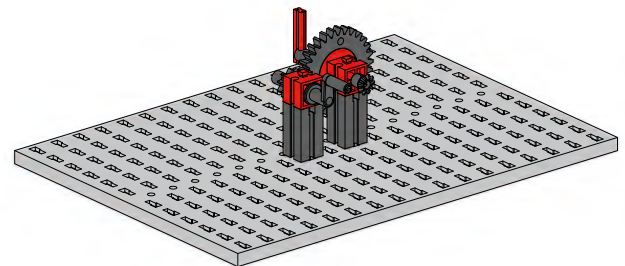

3:1 Stirnradgetriebe / 3:1 Spur gear / 3:1 Réducteur à engrenages cylindriques /
3:1 Tandwiel / 3:1 Engranaje recto / 3:1 Equipamento de esporão /
3:1 Ingranaggio cilindrico / 3:1 Прямозубая шестерня /
3:1 正齿轮 9

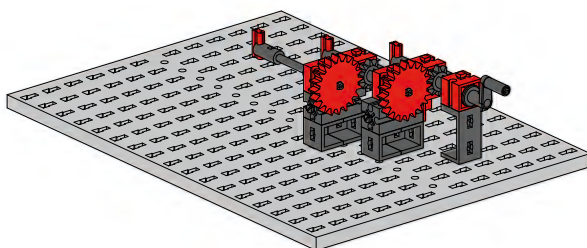

zweistufiges Stirnradgetriebe / two-stage spur gear /
réducteur à engrenages cylindriques à deux étages / tweetraps tandwiel / engranaje
recto de dos etapas / engrenagem de esporão de dois estágios /
ingranaggio cilindrico a due stadi / двухступенчатая
цилиндрическая передача / 两级正齿轮 11

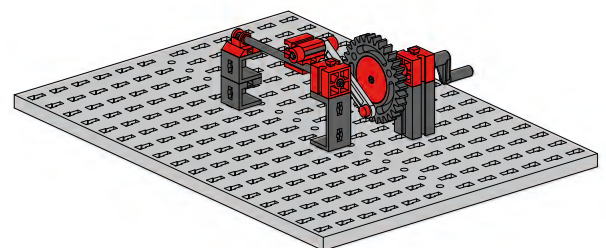

Schubkurbel / Push crank / Manivelle de poussée / Duwkruk / Manivela de empuje /
Manivela de empurrar / Manovella di spinta / Нажимная рукоятка /
推动曲柄 13

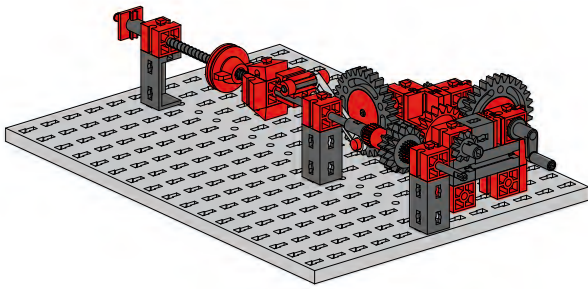

Bohrhammer / Hammer drill / Marteau perforateur / Hamerboor / Martillo perforador /
 Martelo perfurador / Trapano a percussione / Дрель с молотком /
 锤钻 16

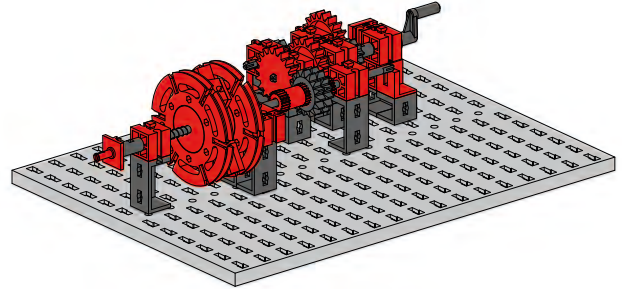

Schlagbohrer / Percussion drill / Perceuse à percussion / Slagboor /
 Taladro de percusión / Perfuratriz de percussão / Trapano a percussione /
 Ударная дрель / 敲击式钻头 22

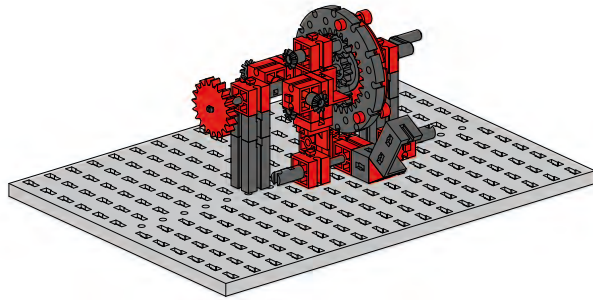

Planetengetriebe / Planetary gear / Réducteur planétaire / Planetair tandwiel /
 Engranaje planetario / Engrenagem planetária / Ingranaggio planetario /
 Планетарная передача / 行星齿轮 28

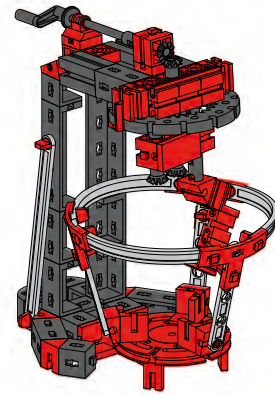

Küchenmaschine / Food Processor / Robot ménager / Keukenmachine /
 Aparato de cocina / Batedeira de cozinha / Robot da cucina /
 Кухонный комбайн / 电动厨具 33

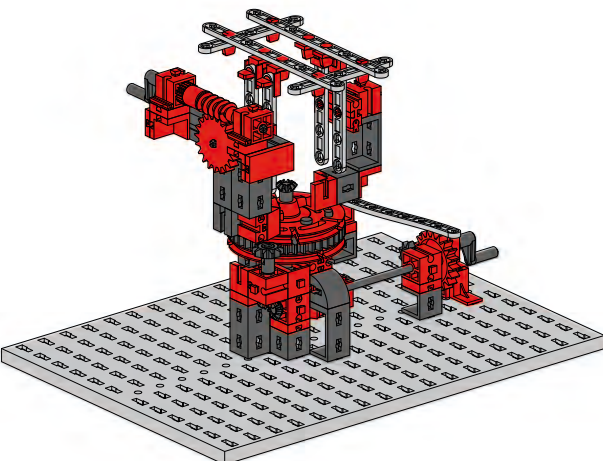

Solartracker / Solar Tracker / Traceur solaire / Zonne tracker / Seguidor solar /
 Rastreador solar / Inseguitore solare / Солнечный трекер /
 太阳能跟踪器 39

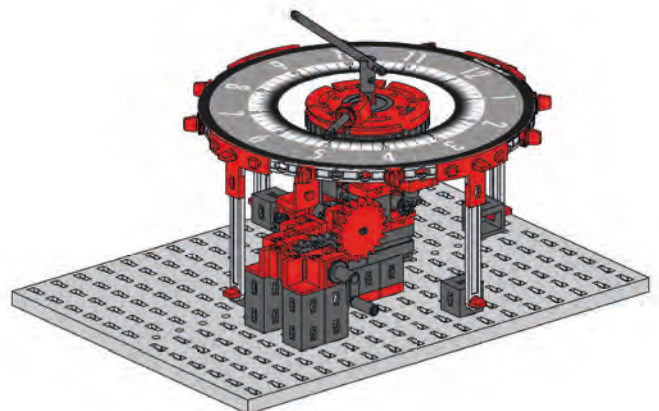

Uhrwerk / Clockworks / Mouvement / Clockwork / Reloj / Clockwork / Orologio /
 Часовой механизм / 发条 48

















Einzelteilübersicht
Spare parts list
Liste des pièces détachées





Onderdelenoverzicht
Lista da piezas
Resumo de peça individual

Singoli componenti
Перечень деталей
零件概览



	31 010 3 x
	31 011 2 x
	31 019 2 x
	31 022 1 x
	31 058 3 x
	31 060 3 x
	31 061 2 x
	31 124 1 x
	31 330 2 x
	31 426 1 x
	31 597 4 x
	31 670 4 x
	31 672 4 x
	31 674 1 x
	31 690 3 x
	31 848 4 x
	31 915 1 x

	31 918 2 x
	31 981 4 x
	31 982 15 x
	32 064 11 x
	32 316 1 x
	32 330 2 x
	32 879 2 x
	32 881 2 x
	35 031 3 x
	35 061 2 x
	35 062 4 x
	35 063 5 x
	35 064 2 x
	35 065 1 x
	35 066 2 x
	35 073 1 x
	35 088 2 x



	35 113 1 x
	35 694 1 x
	35 695 2 x
	35 799 1 x
	35 945 3 x
	36 227 3 x
	36 264 2 x
	36 323 24 x
	36 334 10 x
	36 819 2 x
	36 920 8 x
	36 921 2 x
	36 922 7 x
	36 950 5 x
	36 973 1 x
	37 237 9 x
	37 468 9 x

	37 527 1 x
	37 679 4 x
	37 858 1 x
	37 925 1 x
	37 926 1 x
	38 240 8 x
	38 246 2 x
	38 413 1 x
	38 423 3 x
	68 535 1 x
	130 593 2 x
	137 677 3 x
	153 670 4 x
	160 542 1 x
	160 543 4 x
	160 548 2 x
	172 542 2 x

Einzelteilübersicht
Spare parts list
Liste des pièces détachées

	173 043 1 x
	173 045 6 x

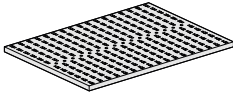
Onderdelenoverzicht
Lista da piezas
Resumo de peça individual

	200 921 1 x
	201 090 1 x

Singoli componenti
Перечень деталей
零件概览

	202 892 1 x

Montagetipps
Tips for assembly
Tuyaux pour le montage

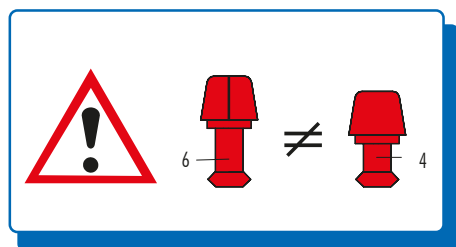

Montagetipps
Consejos para el montaje
"Dicas" para montagem

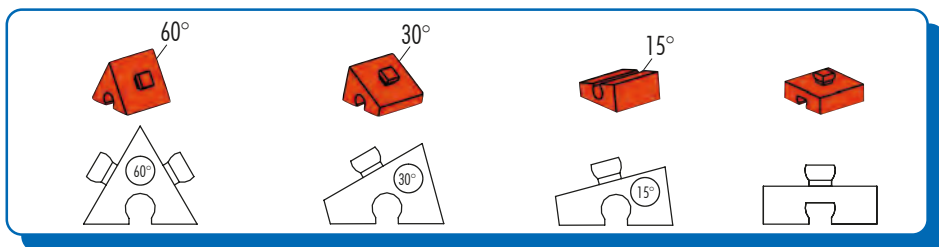

Consigli per il montaggio
Советы по сборке
装配建议

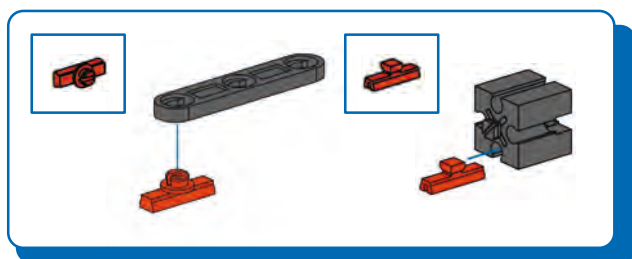

Sicherheitshinweise
Safety Information
Consignes de sécurité

- Achtung! Verletzungsgefahr an Bauteilen mit funktionsbedingten scharfen Kanten und Spitzen!
- Caution! Be careful not to hurt yourself on components with sharp or pointed edges!
- Attention! Risque de blessure sur les éléments comportant des arêtes et o pointes vives indispensables au bon fonctionnement!
- Let op! U kunt zich bezeren aan bouwstenen met scherpe randen of punten!
- Atención! ¡cuidado, no te hagas daño con los componentes con bordes afilados o puntiagudos!

Veiligheidsrichtlijnen
Indicaciones de seguridad
Observações sobre segurança

Informazioni per la sicurezza
Указания по технике безопасности
安全指南

- Atenção! Perigo de ferimentos em peças componentes com cantos vivos e pontas obrigatórios para o funcionamento !
- Attenzione! Pericolo di lesioni dovute a componenti con spigoli vivi e punte per motivi funzionali!
- Будьте осторожны! Об острые края деталей и и наконечники можно порезаться!
- 注意！因功能需要而带有锋利的棱边和尖角的部件可能会带来受伤危险！

- Alle Einzelteile, insbesondere bewegliche Teile sind falls notwendig zu warten und zu reinigen.
- All components, especially moving parts, should be maintained and cleaned as necessary.
- Toutes les pièces détachées et en particulier les pièces mobiles, sont, si nécessaire, à entretenir et à nettoyer.
- Alle onderdelen, vooral de bewegende delen, kunnen, indien noodzakelijk, onderhouden en gereinigd worden.
- Es necesario limpiar y mantener en buen estado todas las diferentes piezas - especialmente las piezas móviles.

- Caso necessário, todas as peças individuais, especialmente peças móveis, tem que ser submetidas à manutenção e ser limpas.
- Se necessario, tutti i singoli componenti, soprattutto le parti mobili, si devono eventualmente sottoporre a manutenzione e pulizia.
- Все детали, особенно подвижные, требуют ухода и чистки.
- 必要时应保养和清洁所有零件，尤指运动部件。

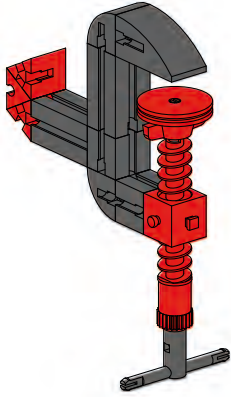



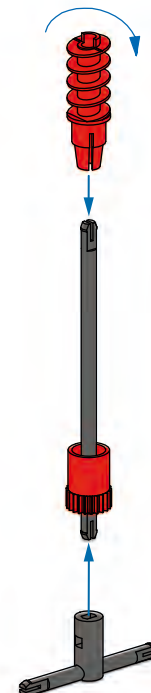
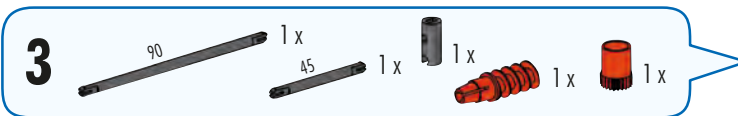
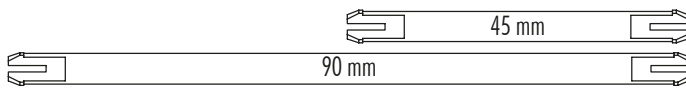
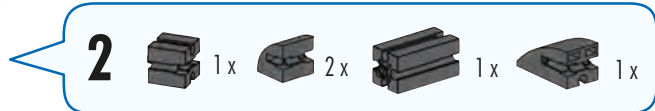
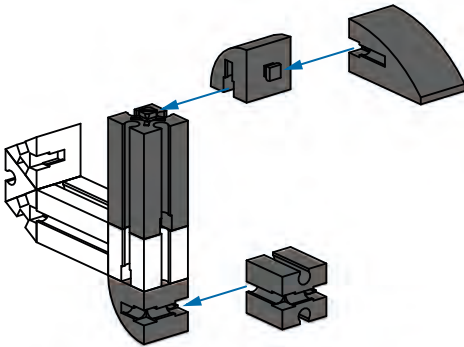
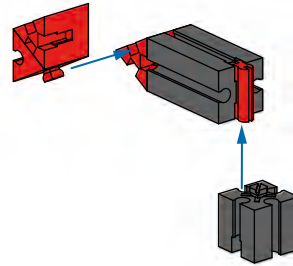
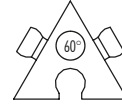
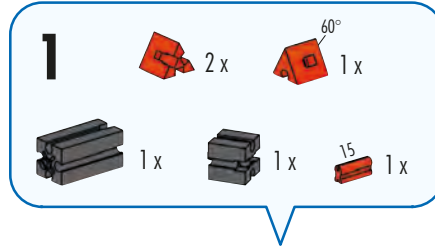

Headsethalter
Headset holder
Porte-casque

Hoofdtelefoonhouder
Soporte para auriculares
Supporte de auscultadores

Supporto per cuffie
Держатель гарнитуры
耳机支架



- 4**  1x  1x  1x  1x

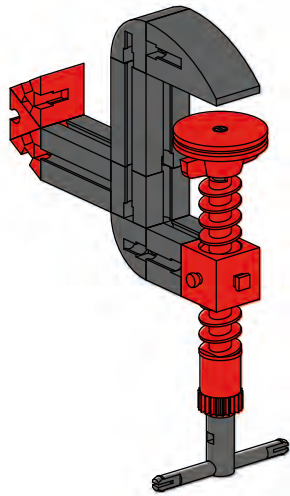
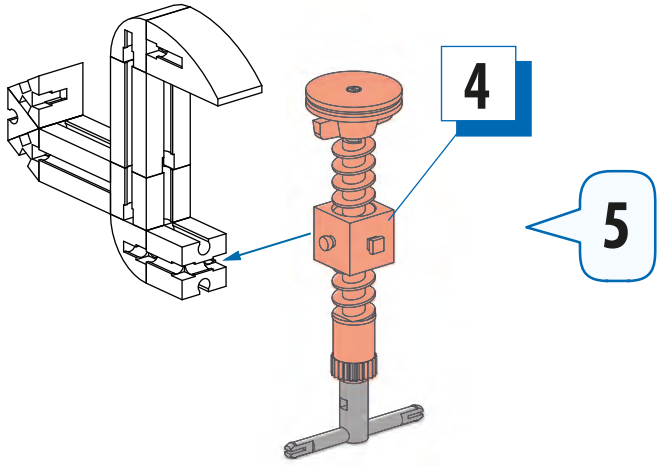
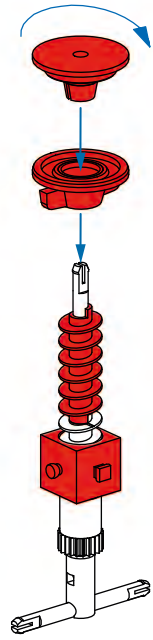



Winkelgetriebe
Angular gear
Réducteur d'angle

Hoekig tandwiel
Engranaje angular
Engrenagem angular

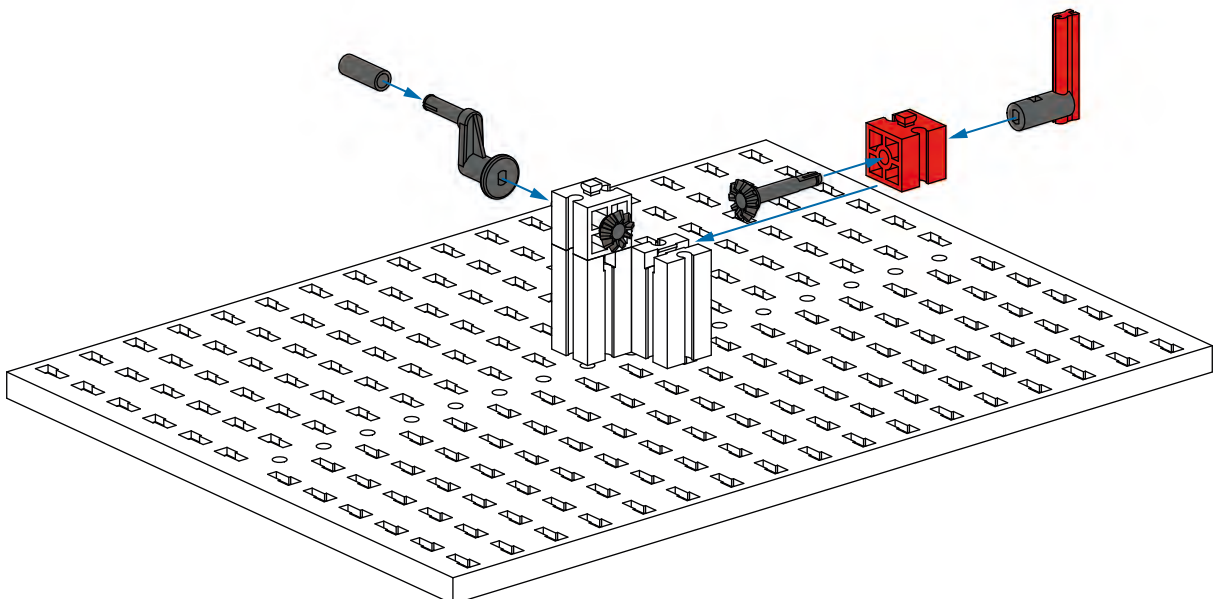
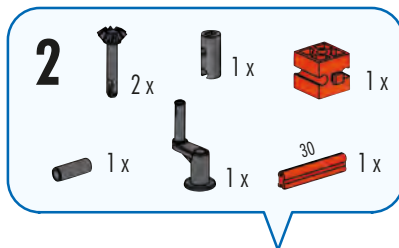
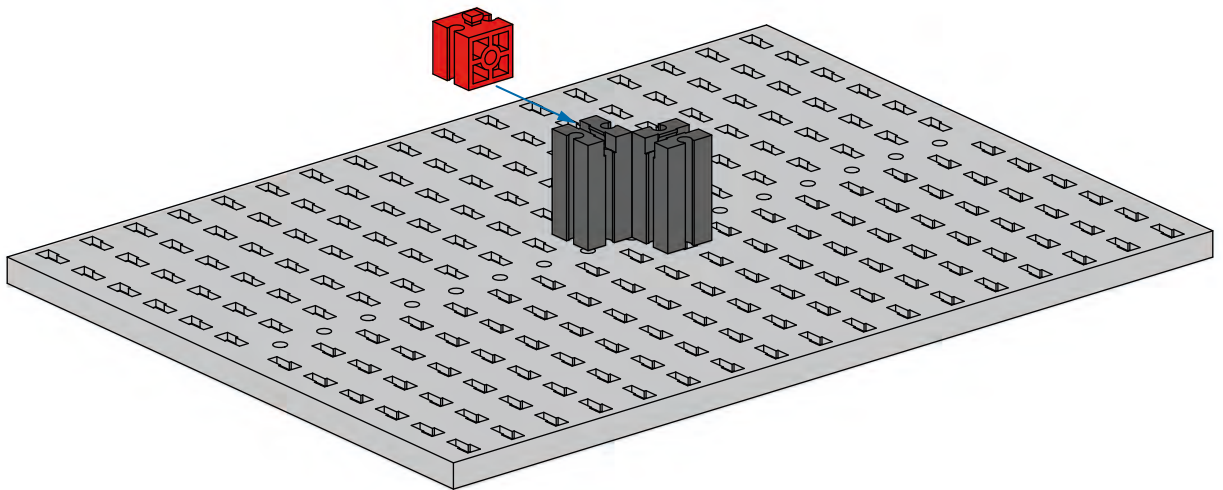
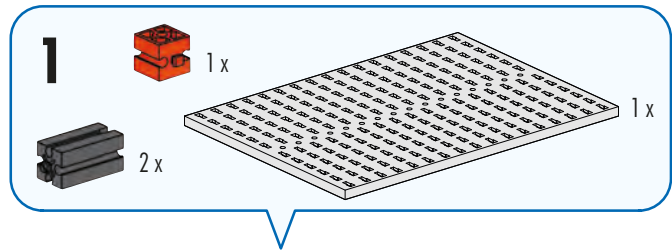
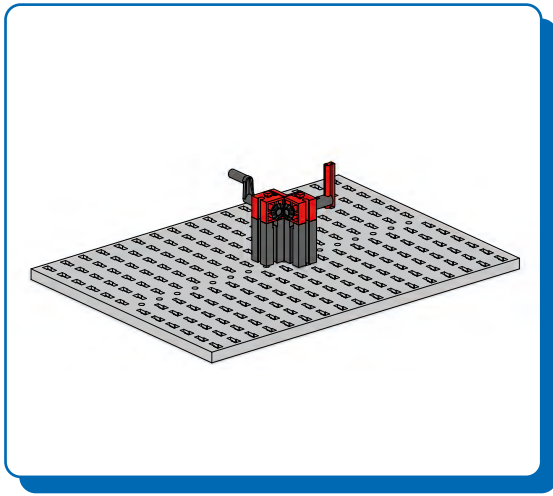
Ingranaggio angolare
Угловая передача
角形齿轮



3  1x  1x

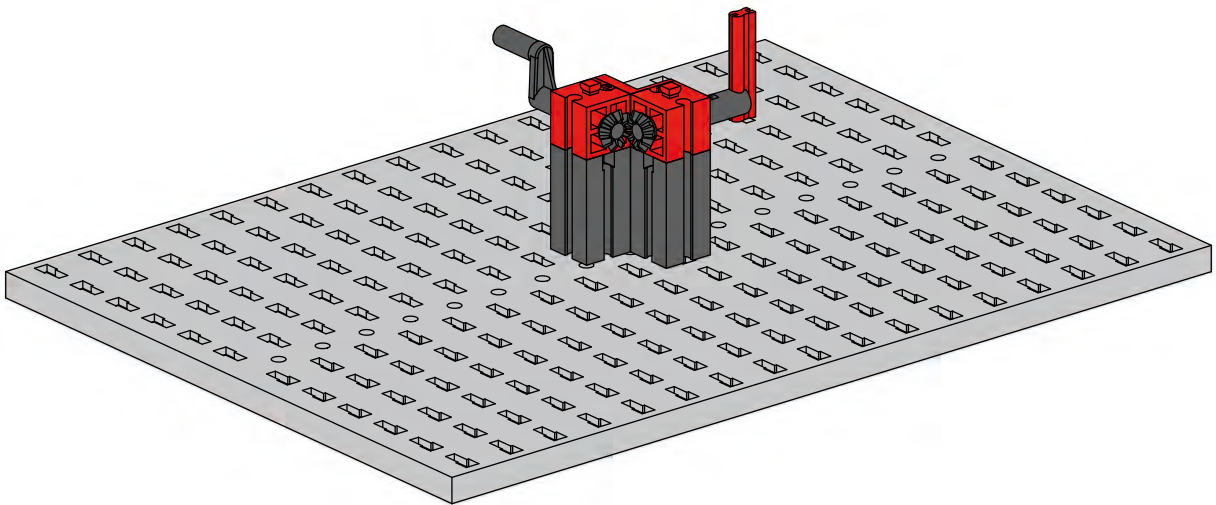
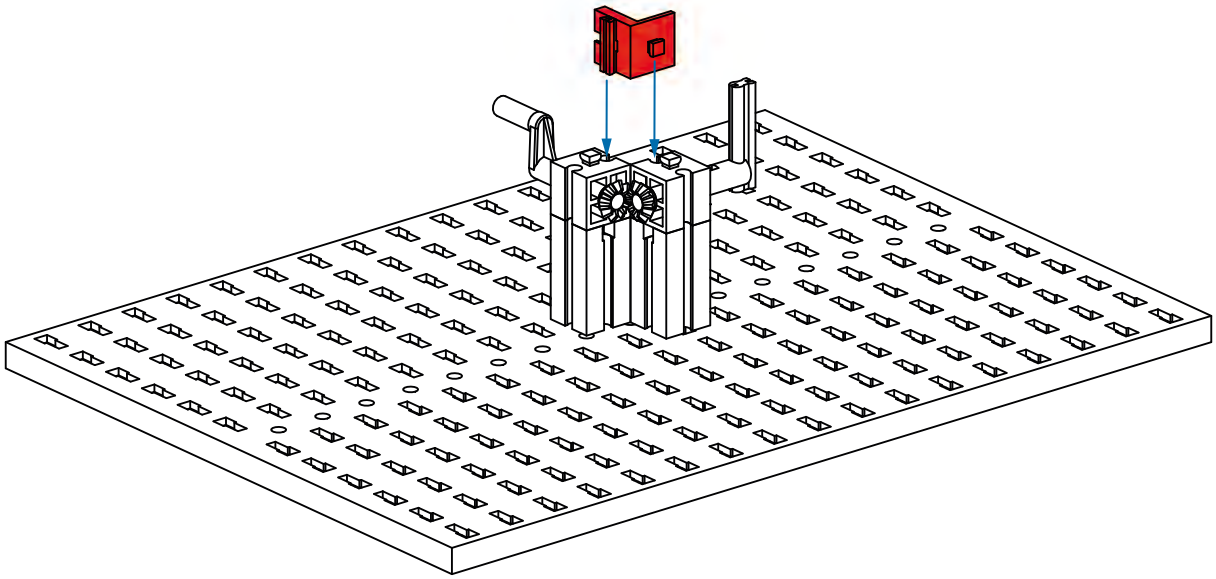

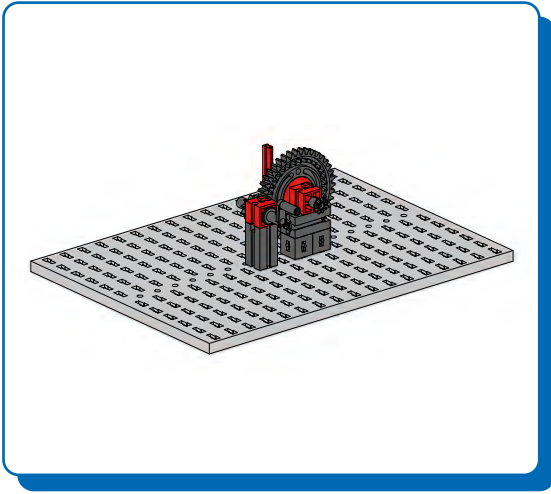

4:1 Stirradgetriebe

4:1 Spur gear

4:1 Réducteur à engrenages cylindriques

4:1 Tandwiel

4:1 Engranaje recto

4:1 Equipamento de engrenajes esporão

4:1 Ingranaggio cilindrico

4:1 Прямозубая шестерня

4:1 正齿轮

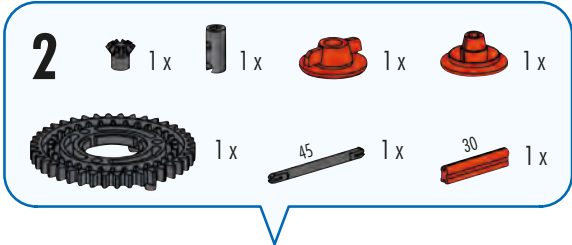
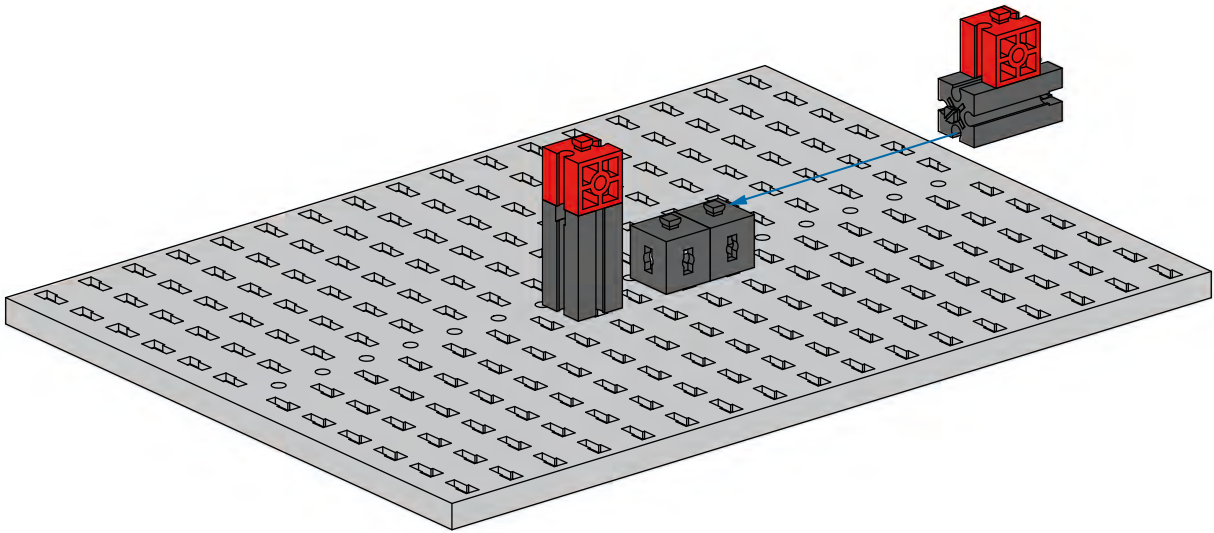
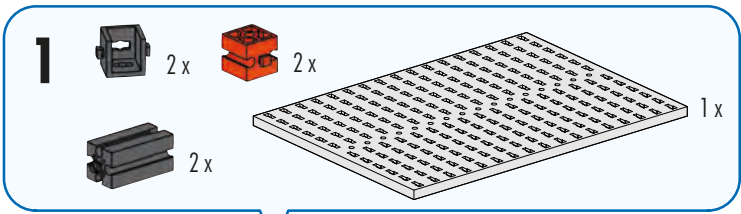

45 mm

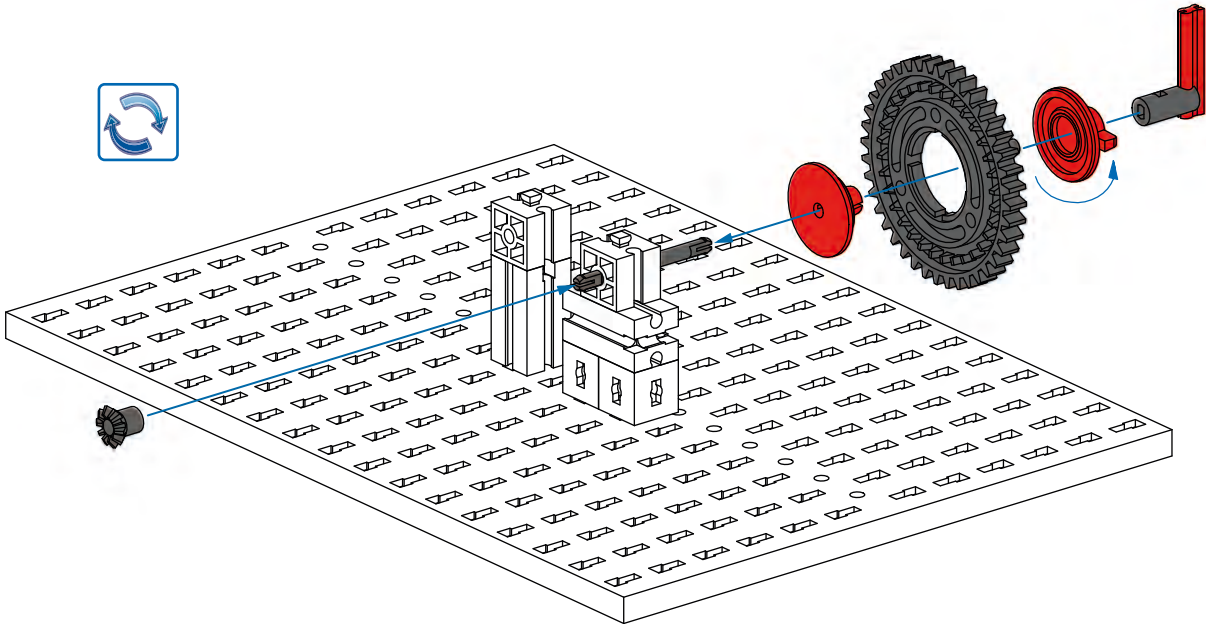

3

- 1x [Pin]
- 1x [Pin 30]
- 1x [Pin with Friction Ridge]
- 1x [L-shaped Pin]

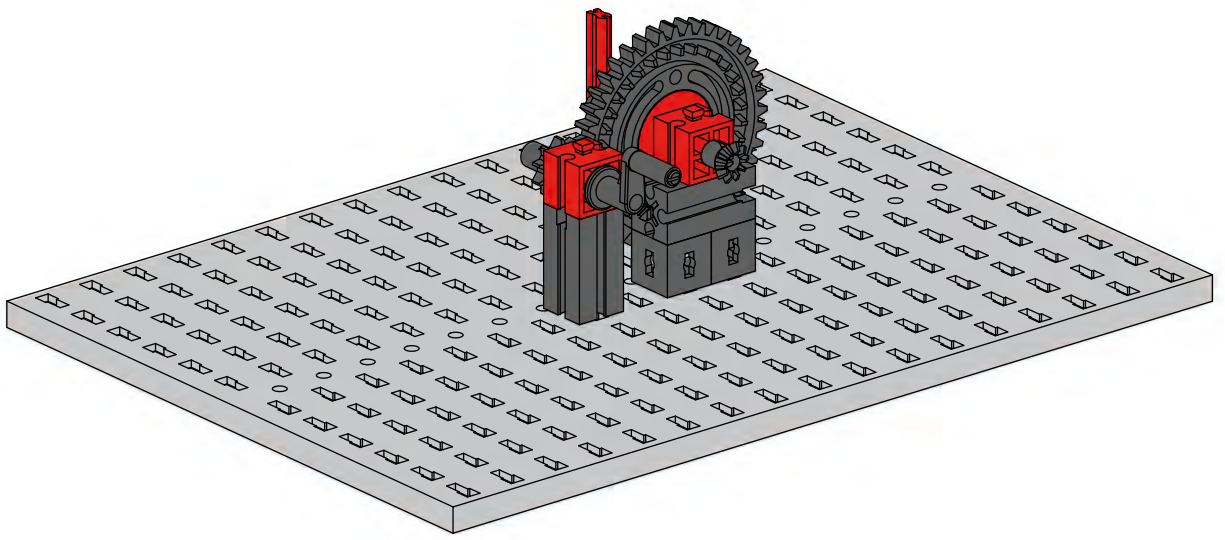
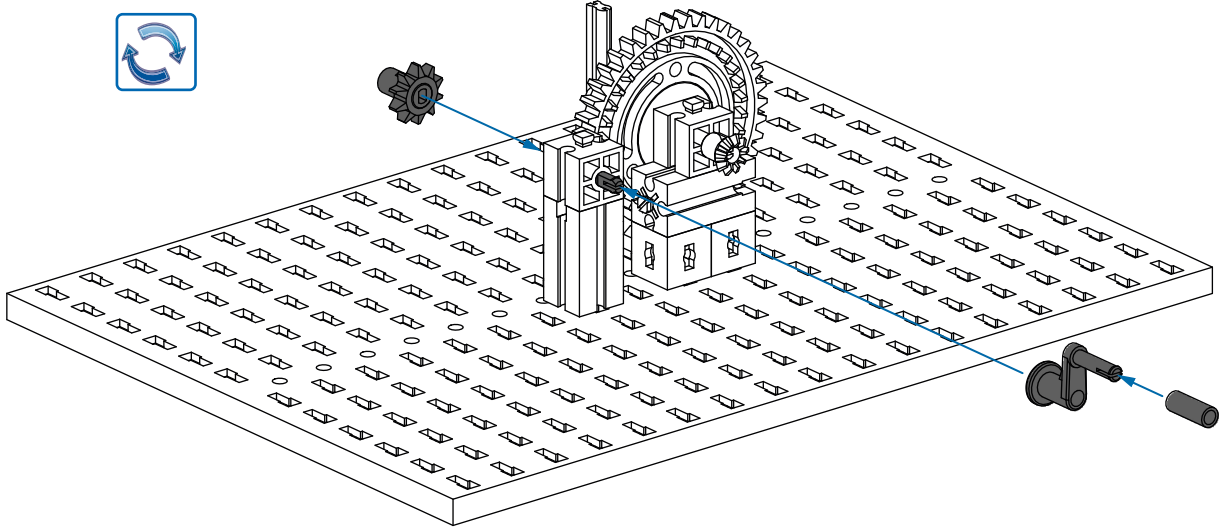
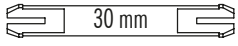

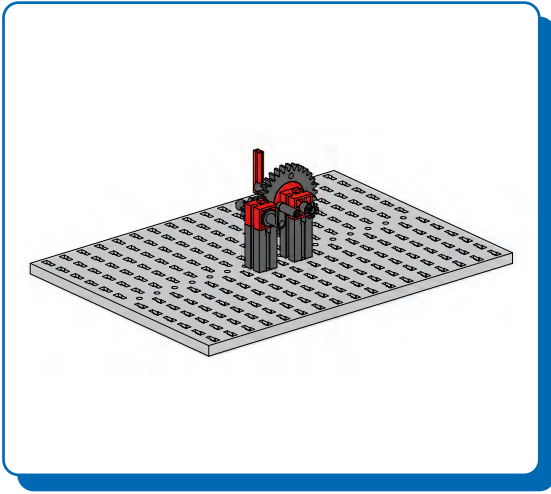

3:1 Stirnradgetriebe

3:1 Spur gear

3:1 Réducteur à engrenages cylindriques

3:1 Tandwiel

3:1 Engranaje recto

3:1 Equipamento de engrenação

3:1 Ingranaggio cilindrico

3:1 Прямозубая шестерня

3:1 正齿轮

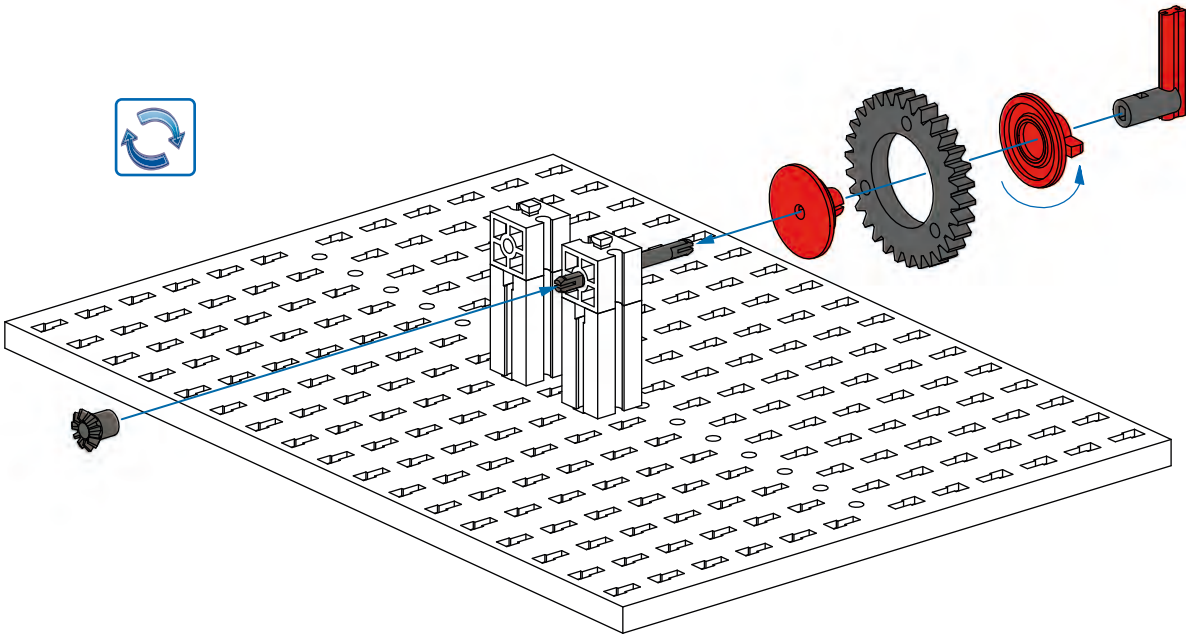
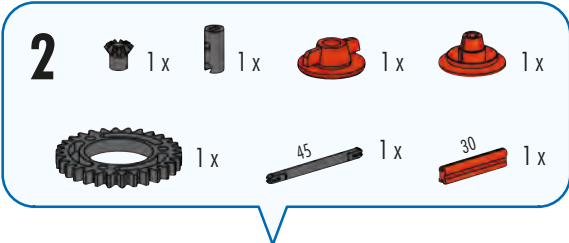
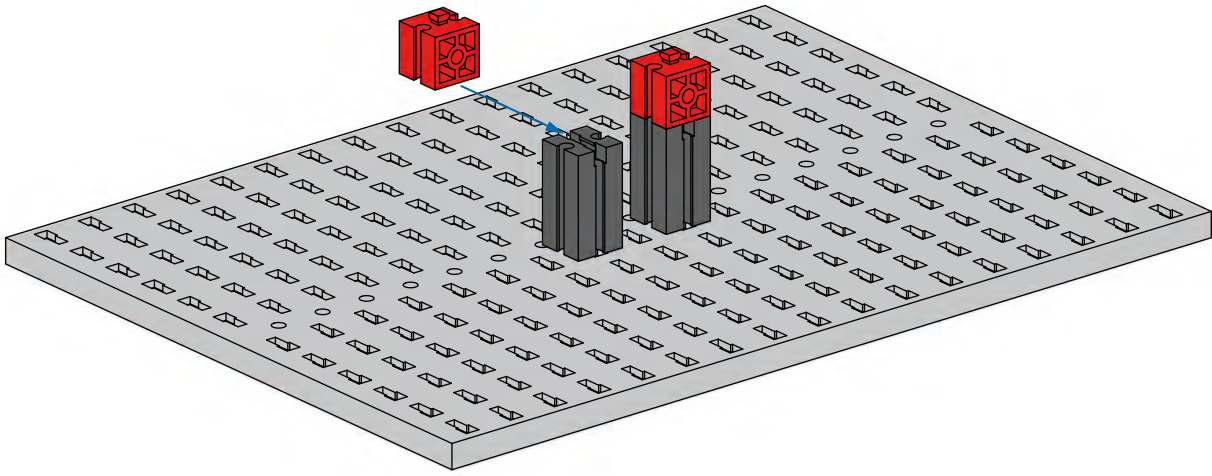
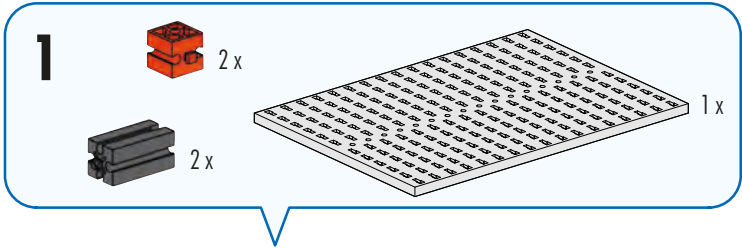

3

- 1 x [Pin]
- 30 1 x [Pin]
- 1 x [Pin]
- 1 x [Pin]

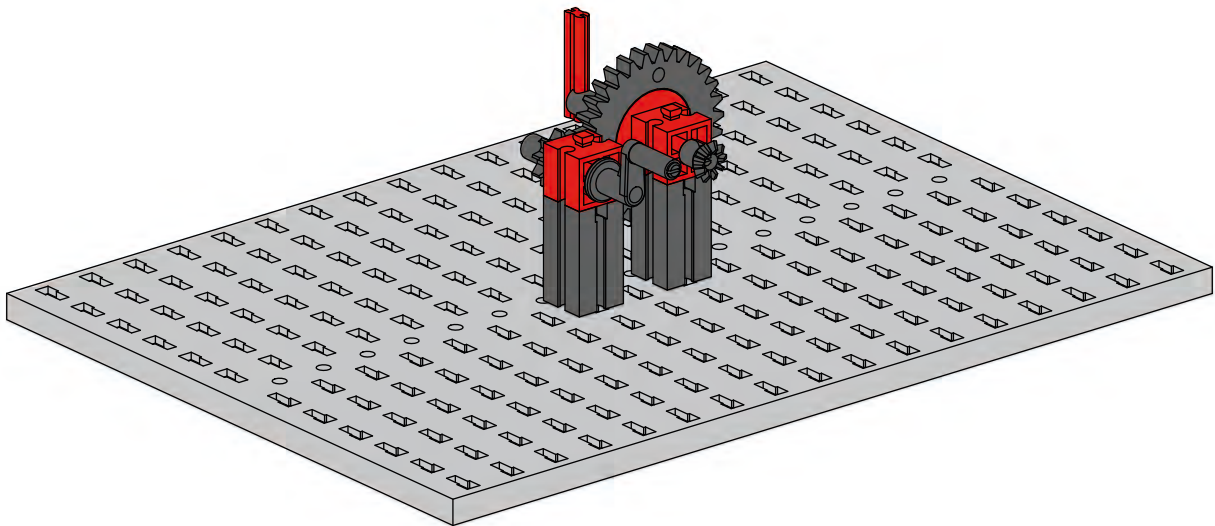
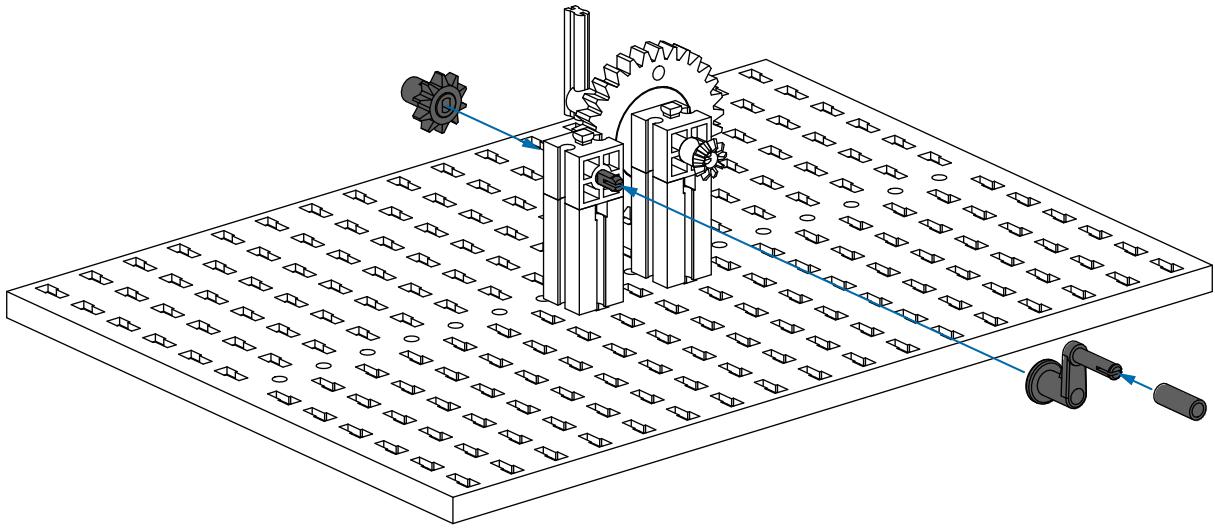
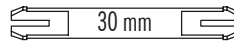

zweistufiges Stirnradgetriebe
two-stage spur gear
réducteur à engrenages
cylindriques à deux étages
tweetraps tandwiel

engranaje recto de dos etapas
engrenagem de esporão de
dois estágios
ingranaggio cilindrico a due
stadi

двухступенчатая
цилиндрическая
передача
两级正齿轮

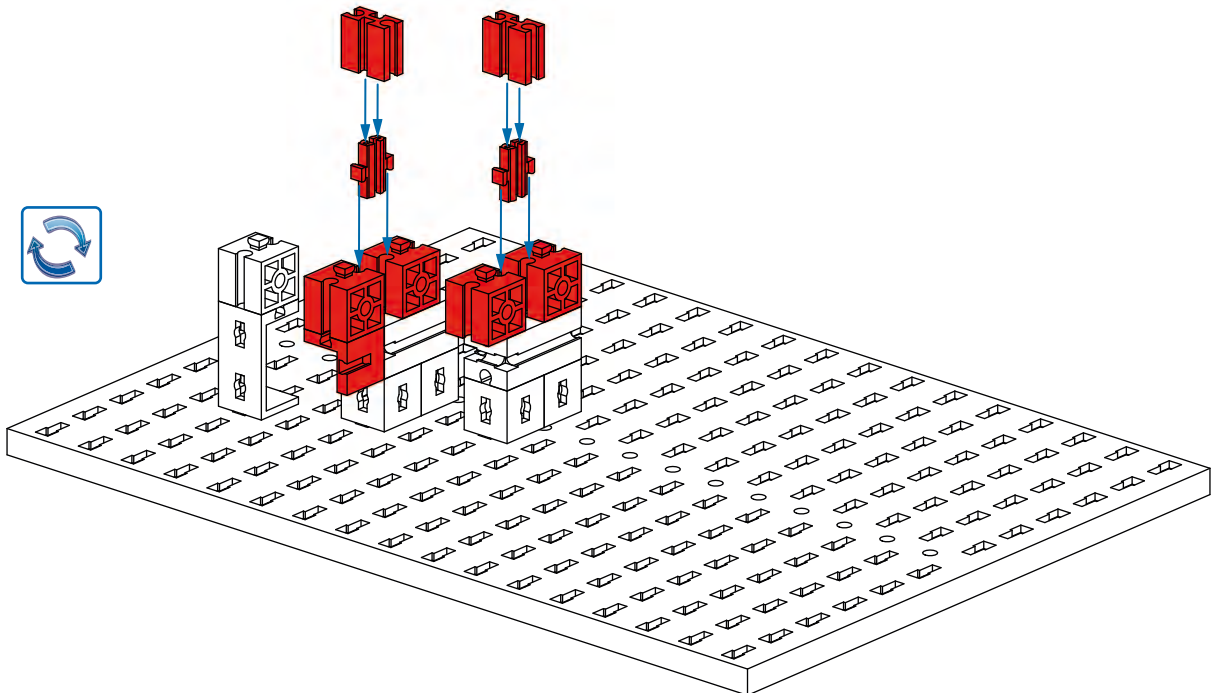
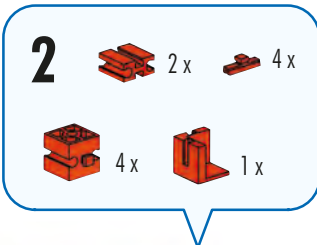
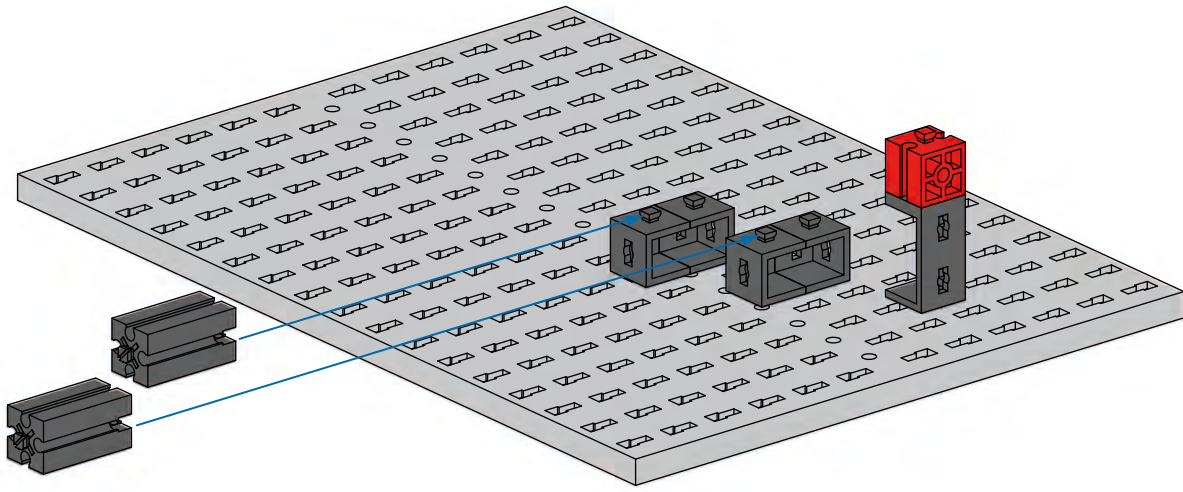
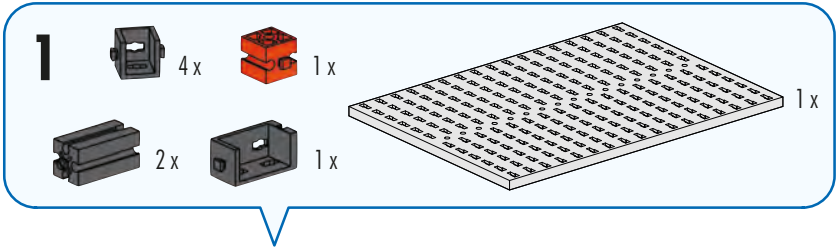
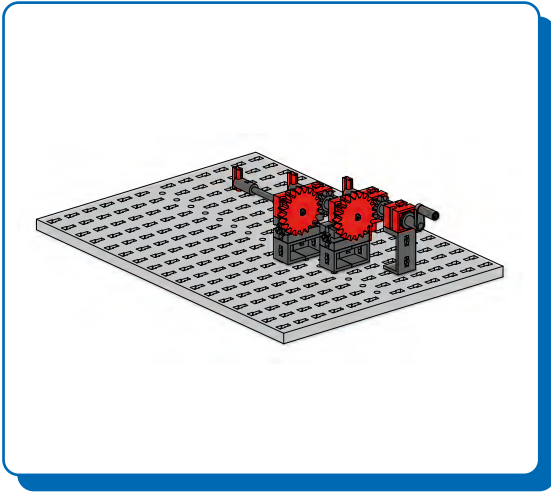

3

- 1 x [Grey Pin]
- 4 x [Grey Pin 30]
- 3 x [Grey Pin]
- 3 x [Red Pin 15]
- 1 x [Red Pin]
- 2 x [Grey Pin]
- 1 x [Grey Pin]
- 1 x [Grey Pin 60]
- 2 x [Red Gear]

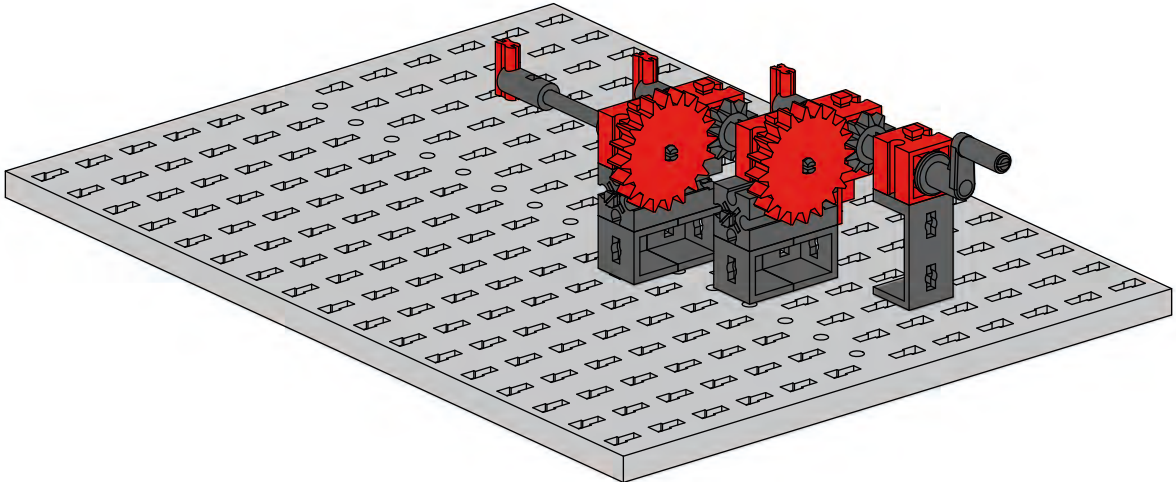
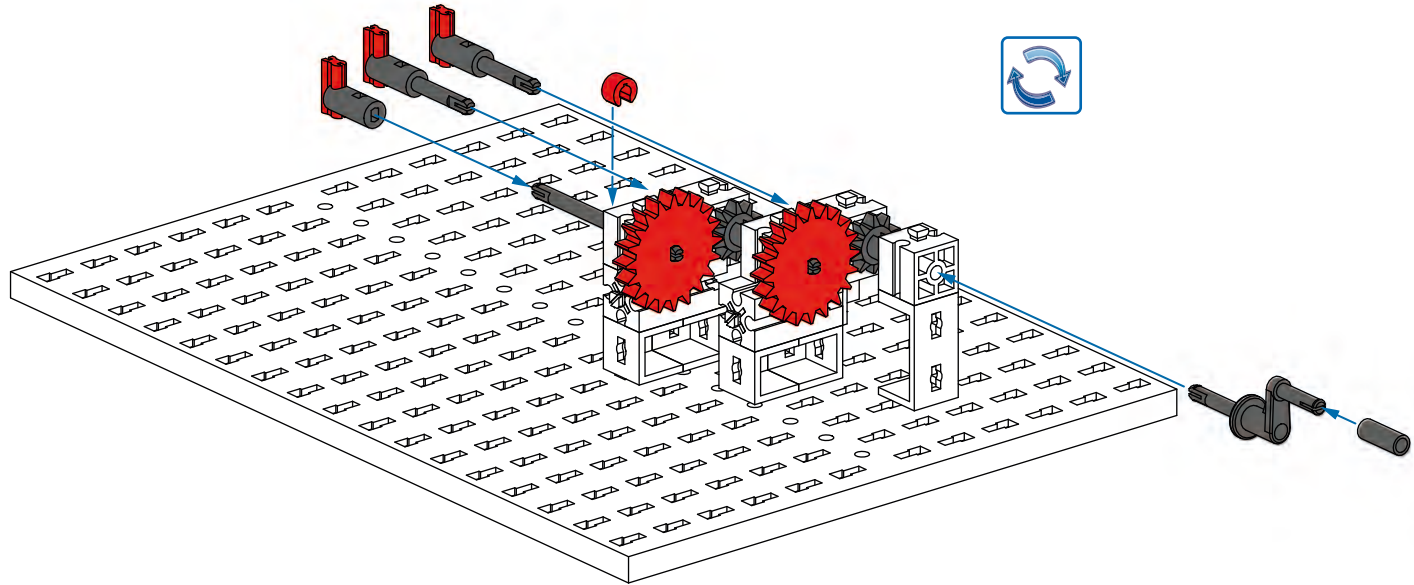
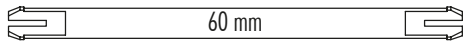



Schubkurbel
Push crank
Manivelle de poussée

Duwkruk
Manivela de empuje
Manivela de empujar

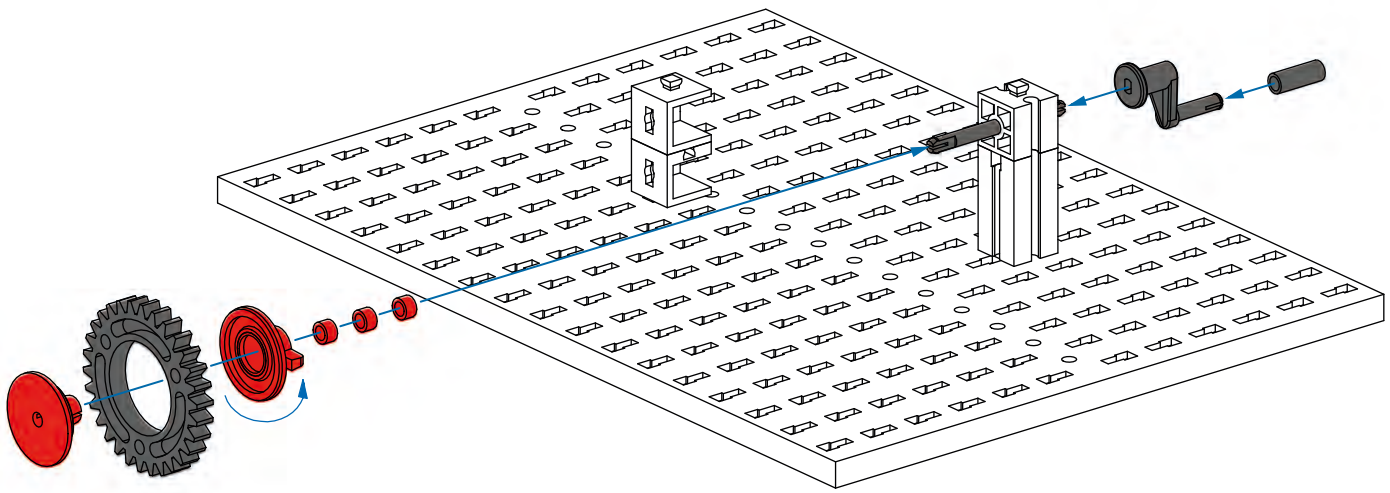
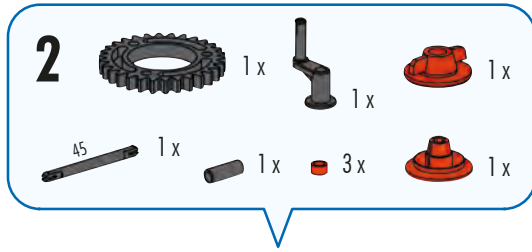
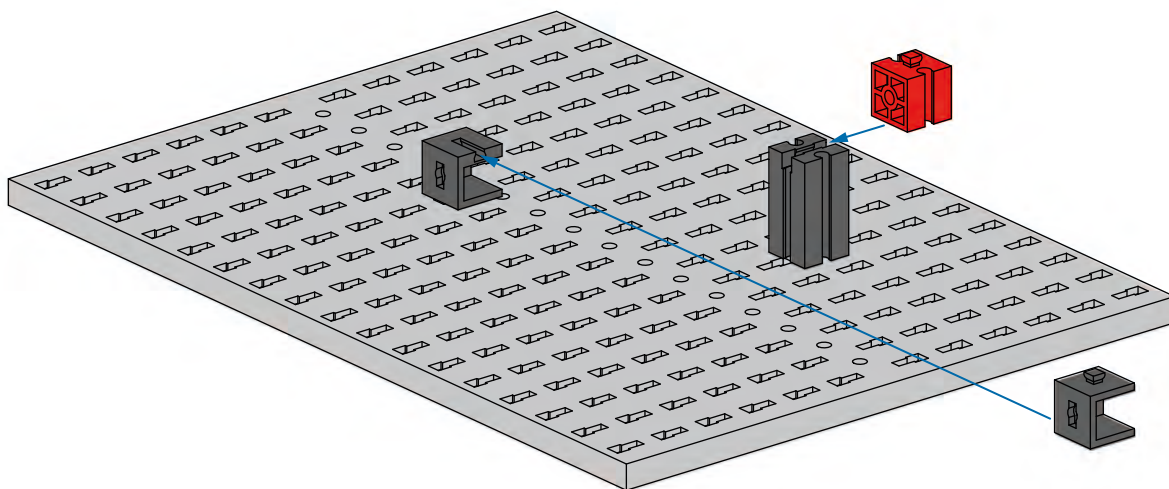
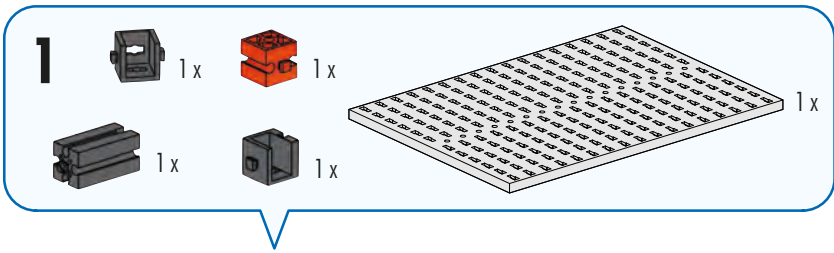
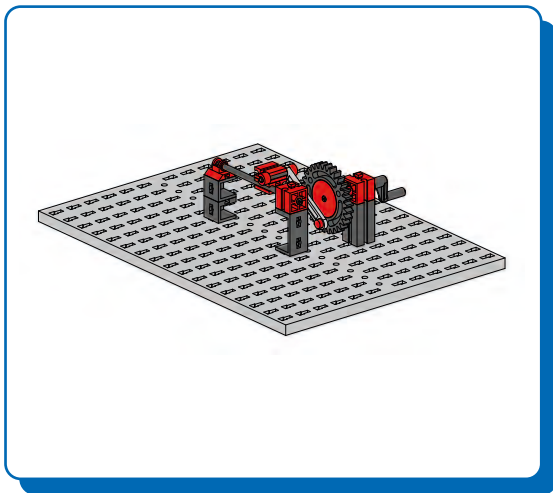
Manovella di spinta
 Нажимная рукоятка
 推动曲柄







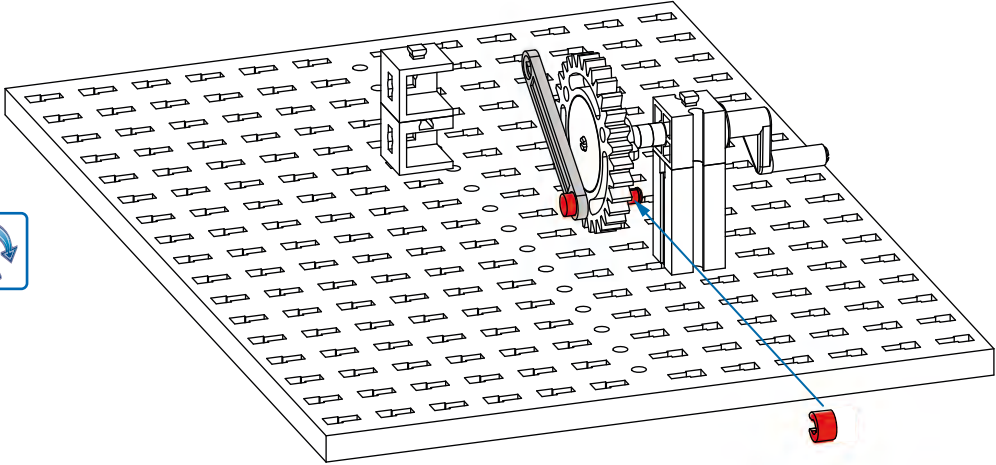

3

- 1x 
- 1x 
- 1x 



90 mm

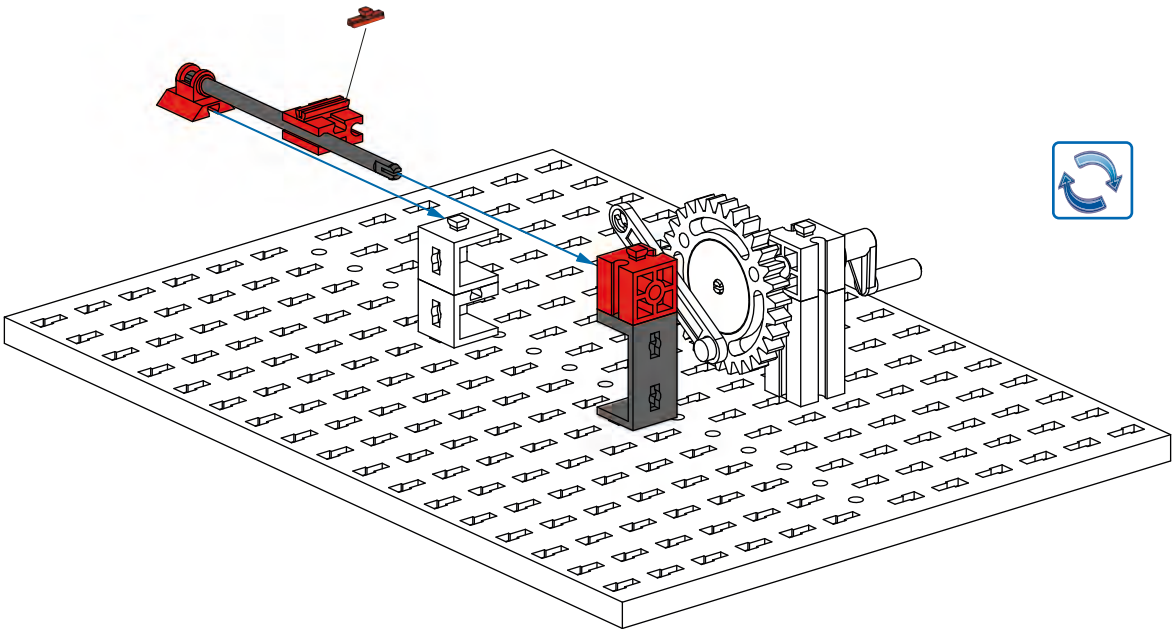

4

- 1x 
- 1x 
- 1x 
- 1x 
- 1x 
- 1x 



30 mm

5

-  2 x
-  30 1 x
-  1 x

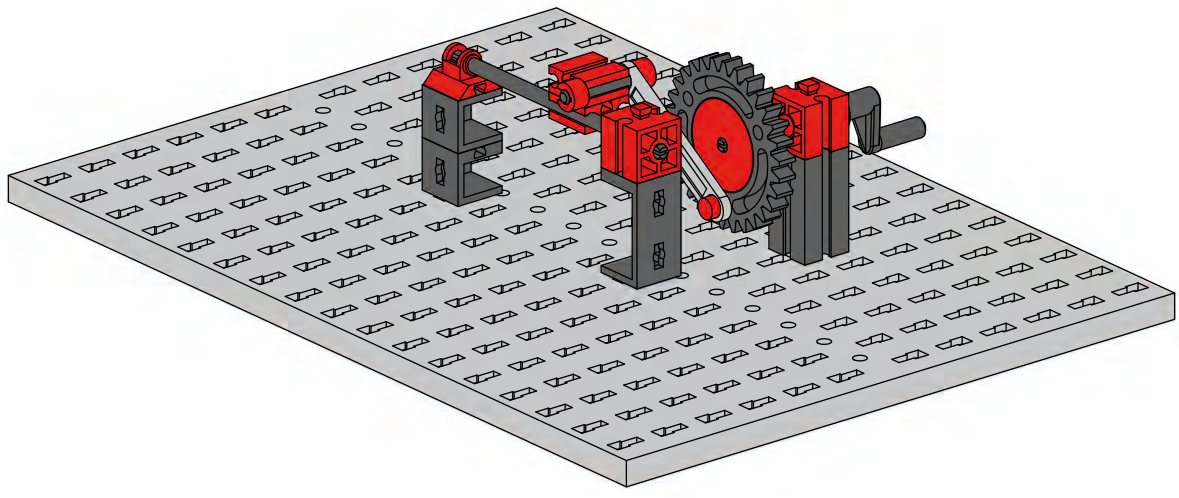
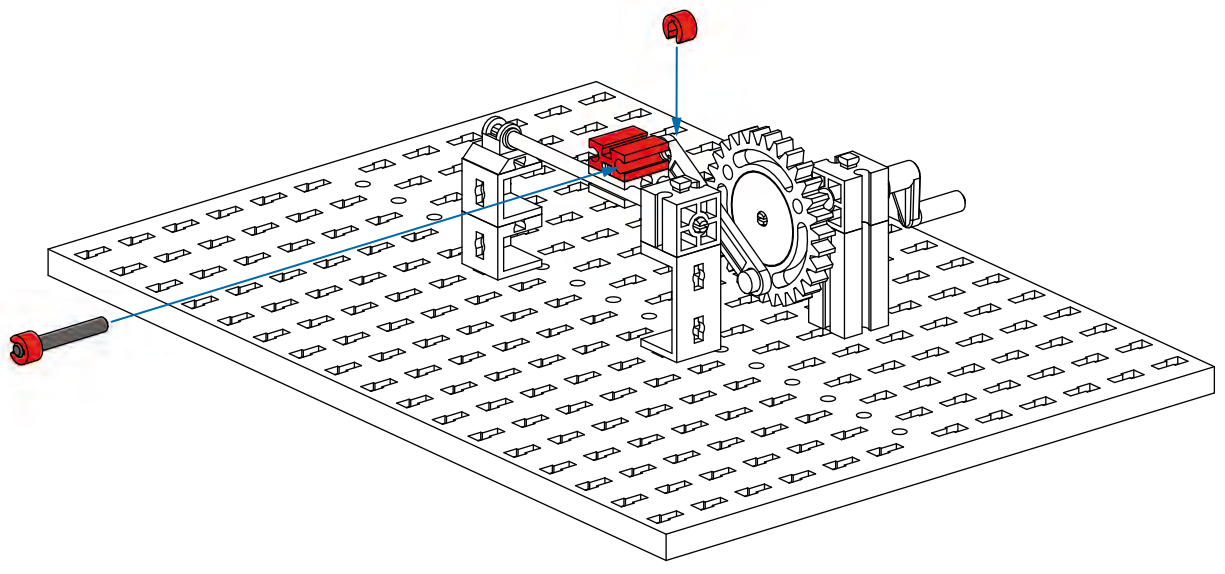





Bohrhammer
Hammer drill
Marteau perforateur

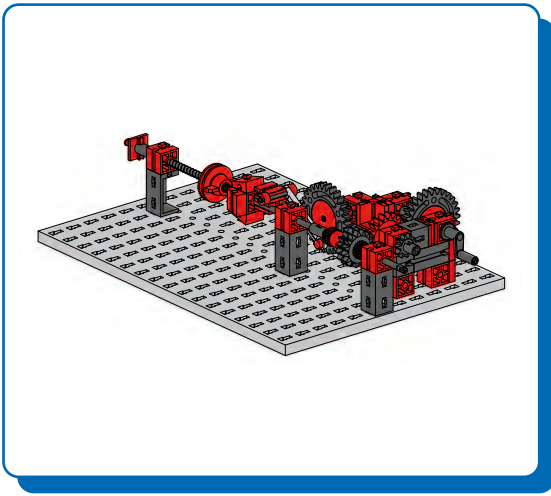



Hamerboor
Martillo perforador
Martelo perforador

Trapano a percussione
 Дрель с молотком
 锤钻

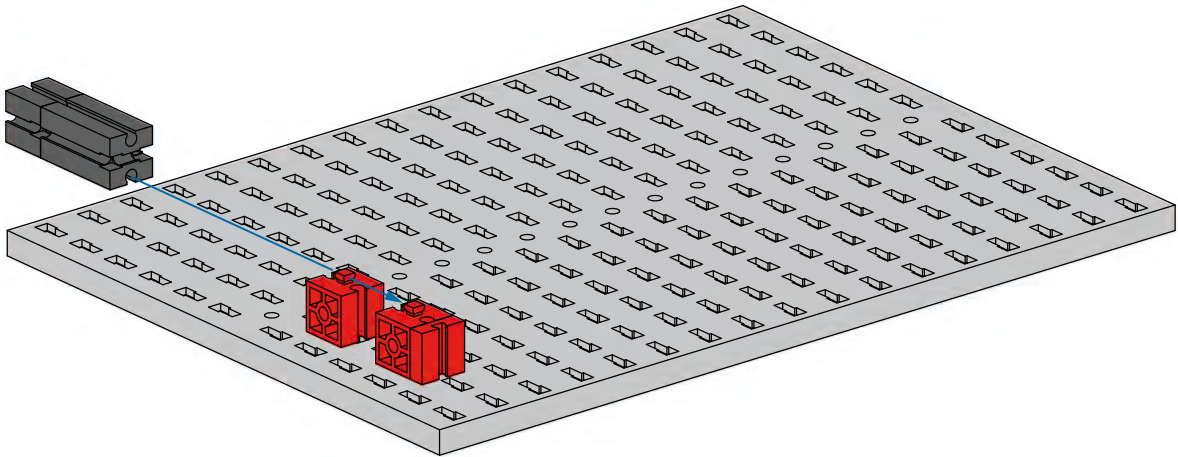
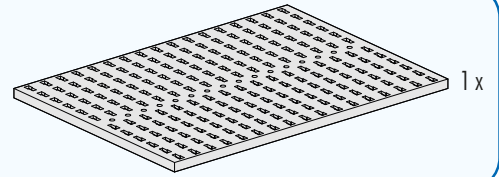

- 1**
-  1x
 -  2x
 -  1x
 -  1x



- 2**
-  1x
 -  1x
 -  1x
 -  2x

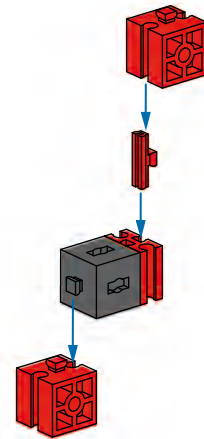

- 3**
-  1x

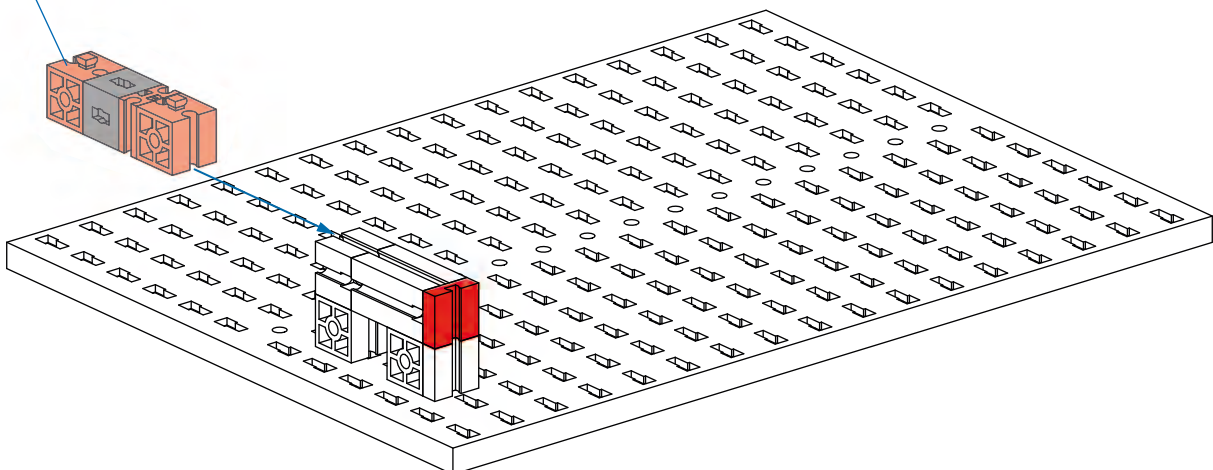
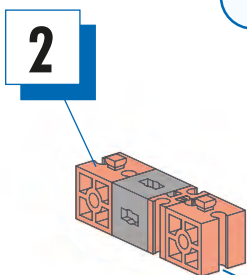

6

2x 1x 1x 1x

1x 45 1x 1x

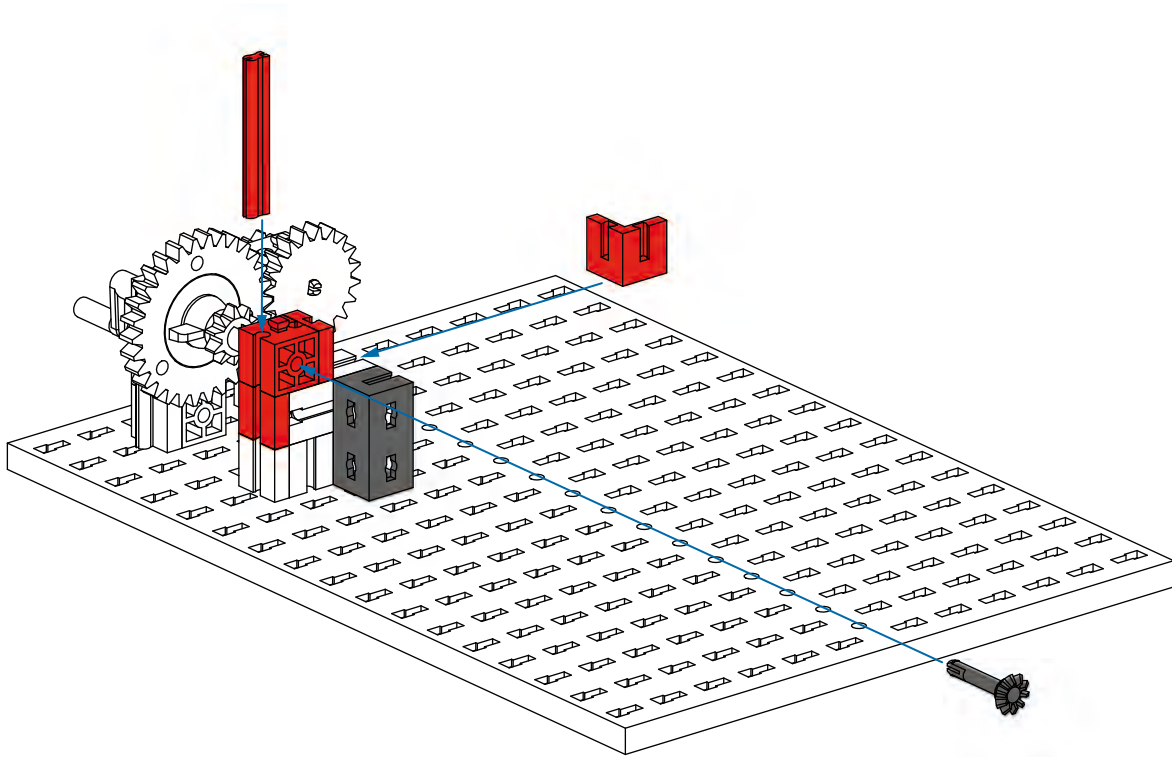

45 mm





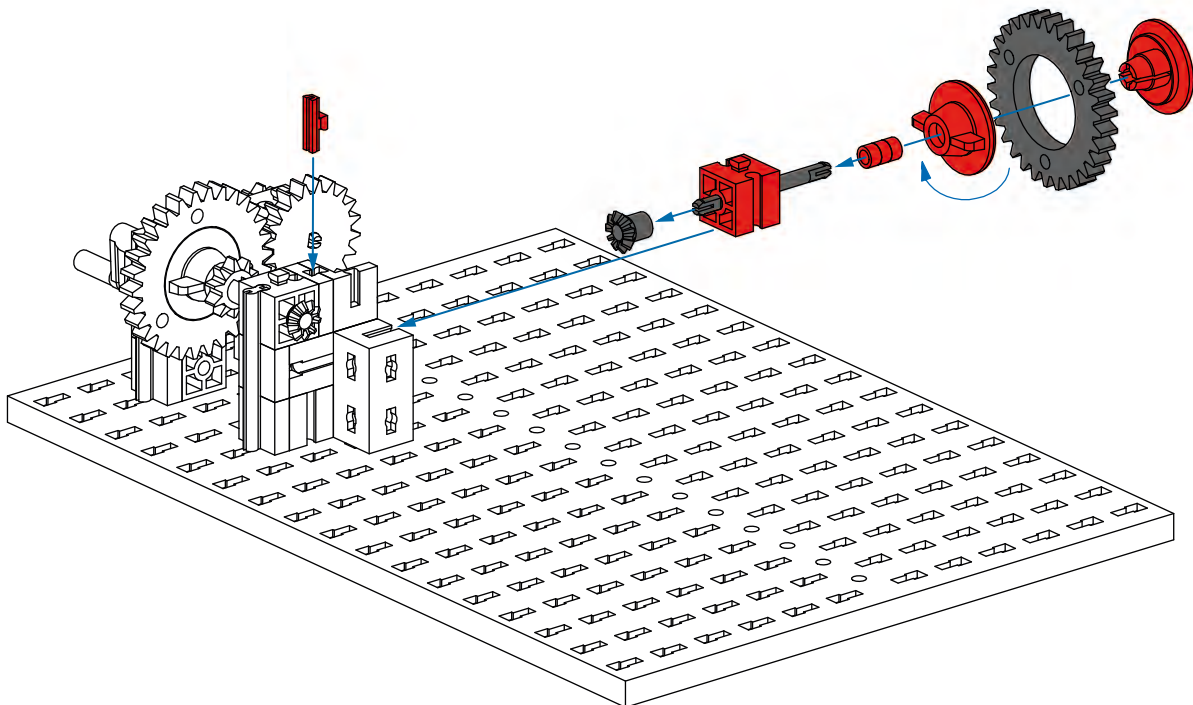

7

1x 1x 1x 3x

1x 45 1x 1x 1x



11

 30 1 x	 45 1 x
 2 x	 1 x
 1 x	 1 x
	 1 x

30 mm

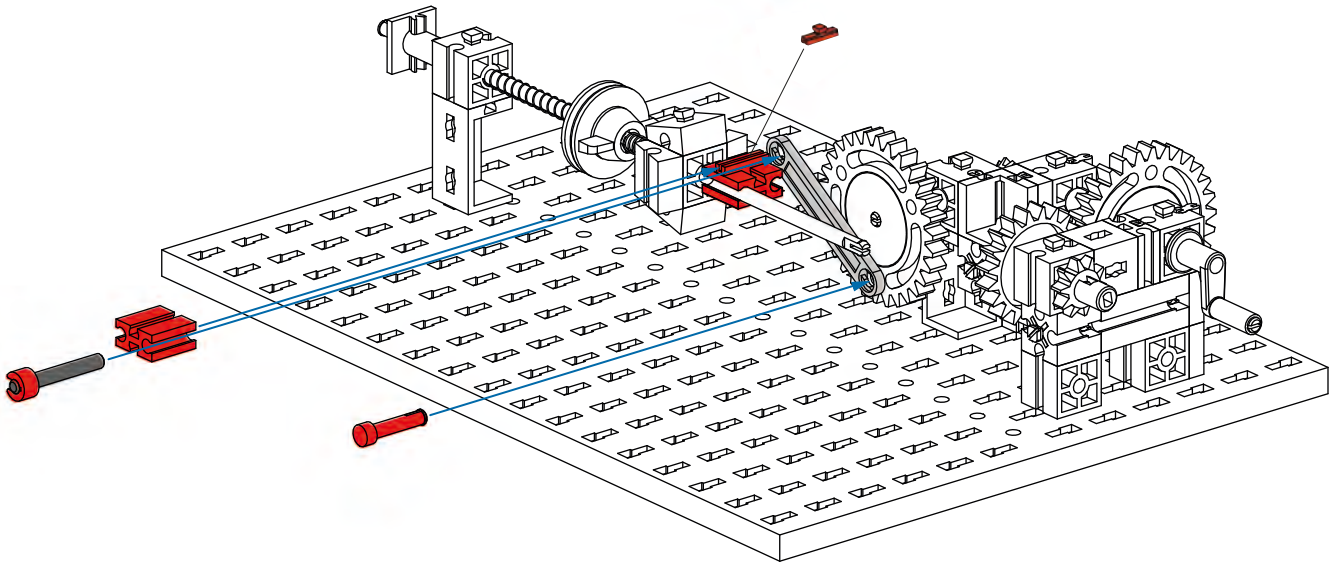

12

 3 x

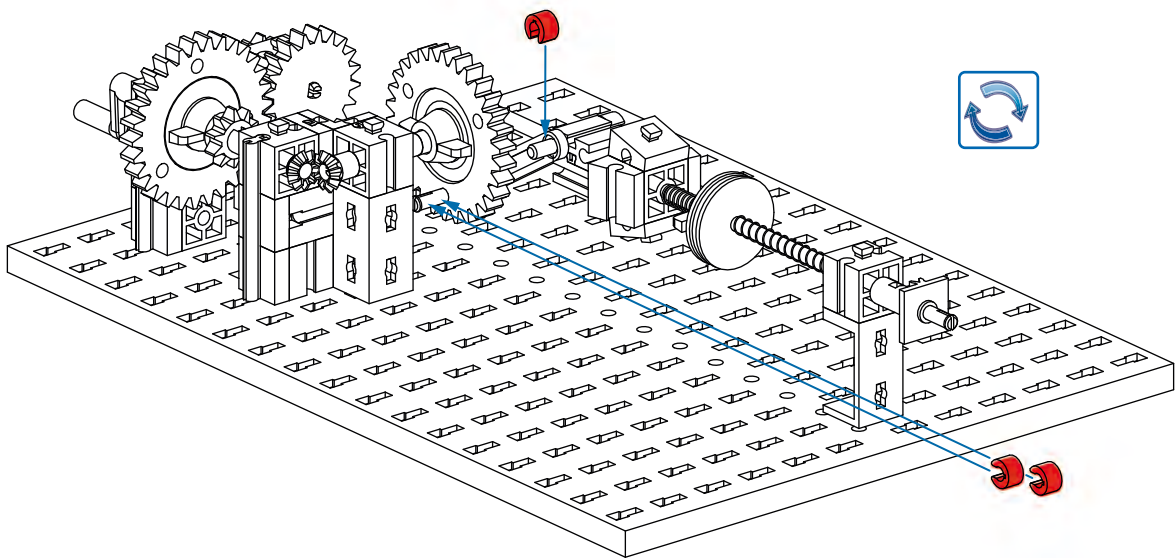

13

- 1x Red 1x2 Technic Brick
- 1x Red Technic Pin
- 1x Red Technic Pin
- 1x Red Technic Pin
- 1x Red Technic Pin
- 1x Grey Technic Axle
- 1x Grey Technic Pin

90 mm

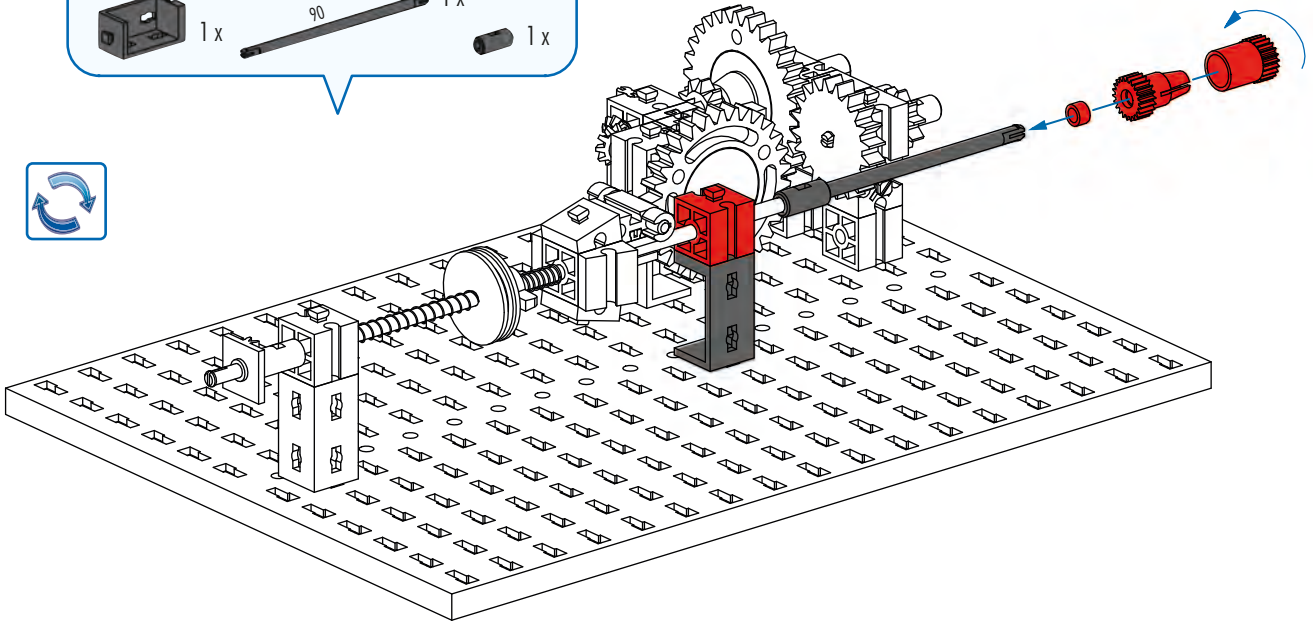

14

- 1x Grey Technic Axle
- 2x Grey Technic Gear
- 1x Red 1x2 Technic Brick
- 2x Red Technic Pin

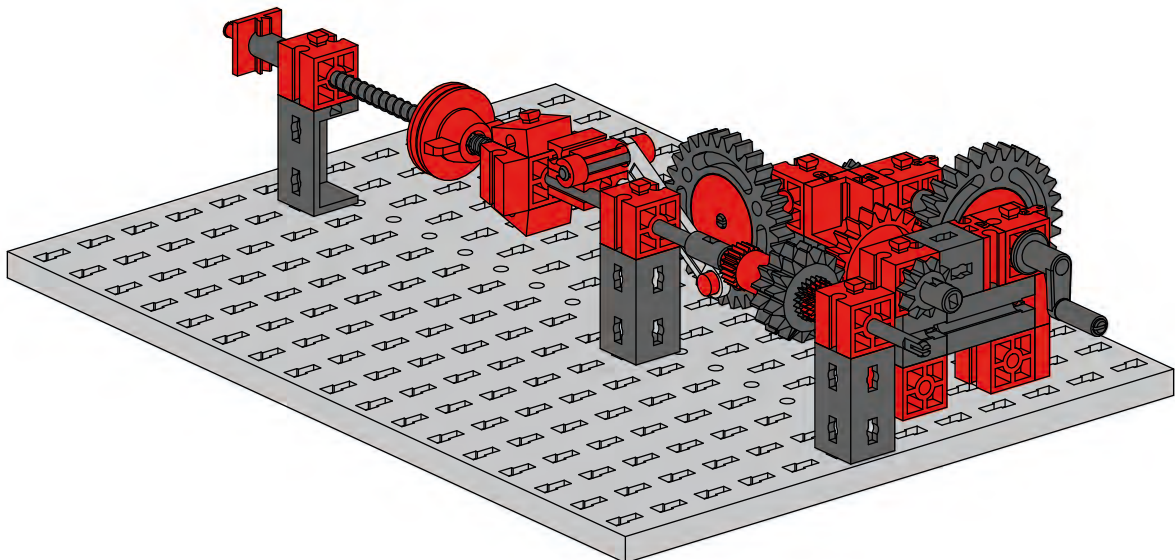
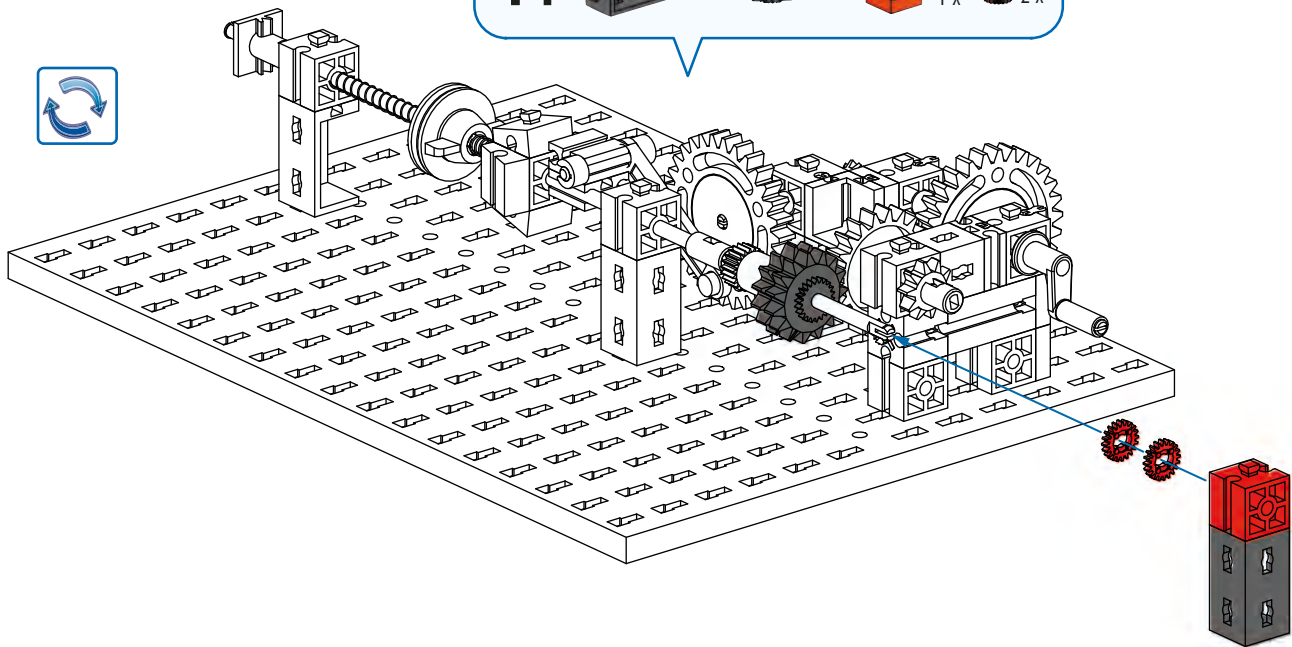

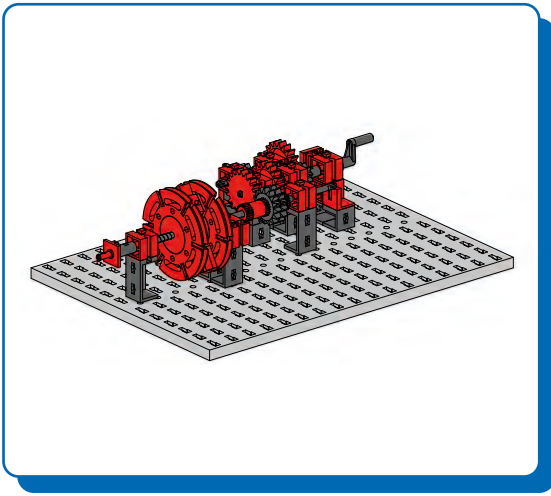

Schlagbohrer
Percussion drill
Perceuse à percussion

Slagboor
Taladro de percusión
Perfuratriz de percussão

Trapano a percussione
Ударная дрель
敲击式钻头

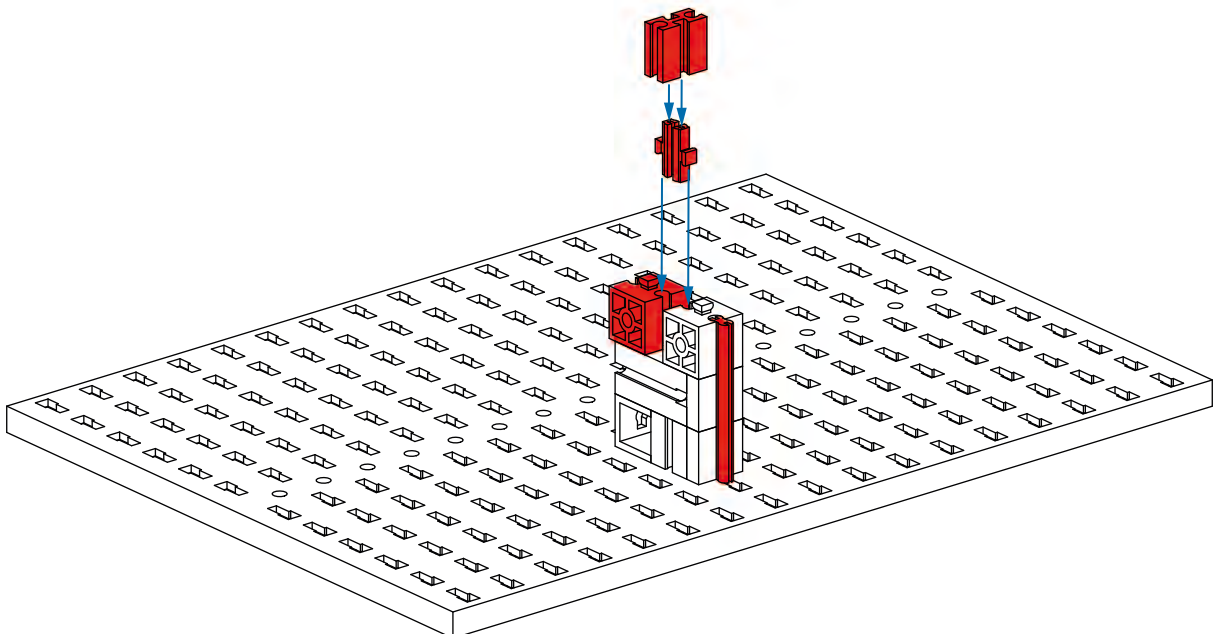
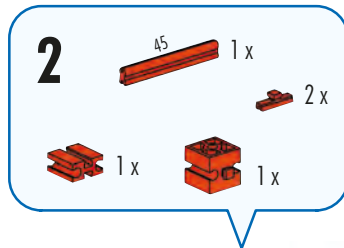
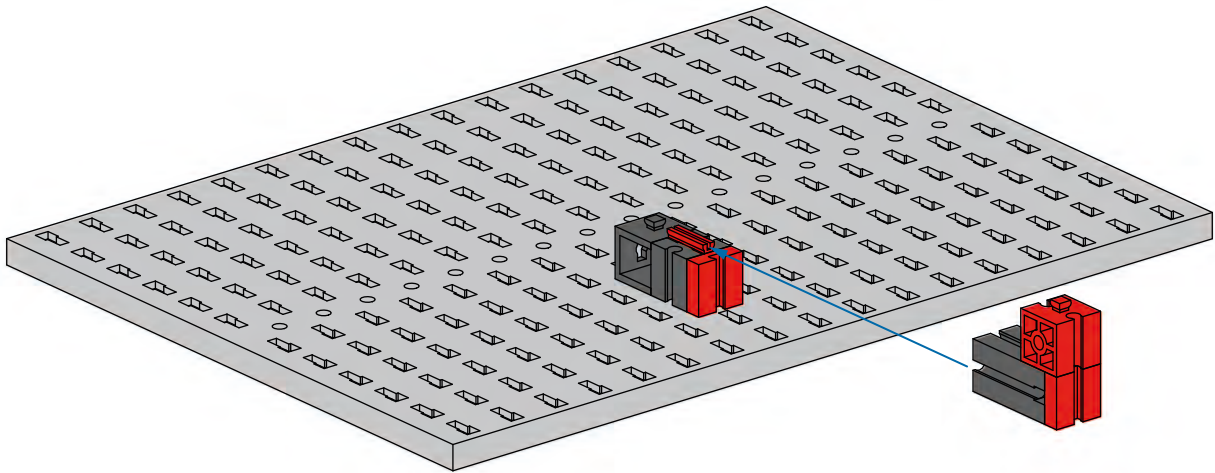
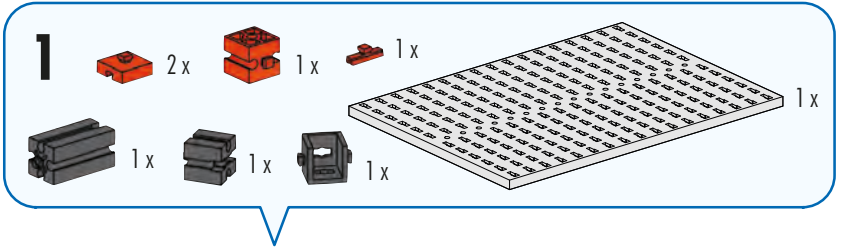

3

30 2x

2x 1x

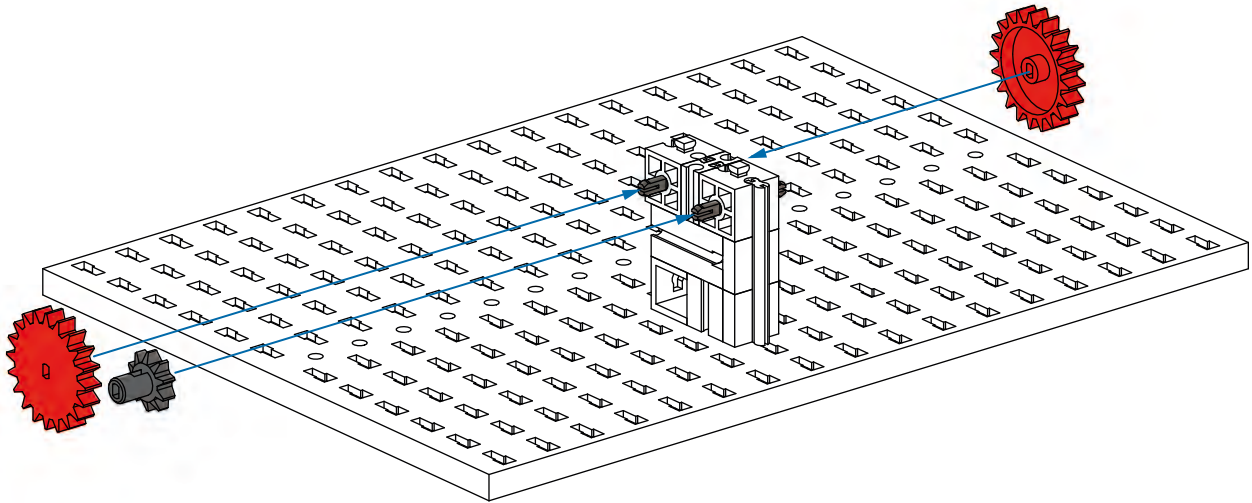
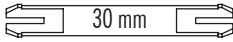

4

1x 2x 1x

1x 1x 1x

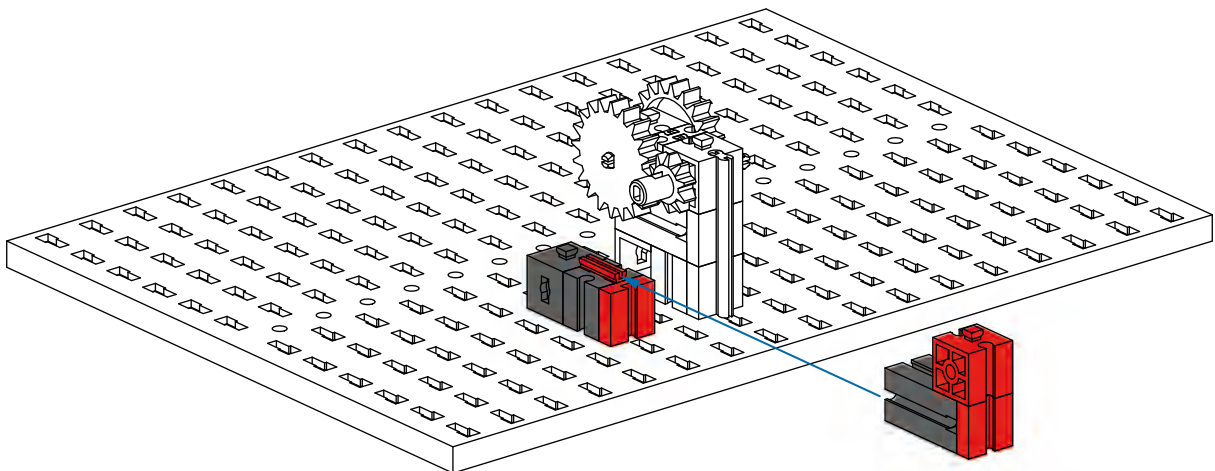

5

- 45 1 x
- 2 x
- 1 x
- 1 x

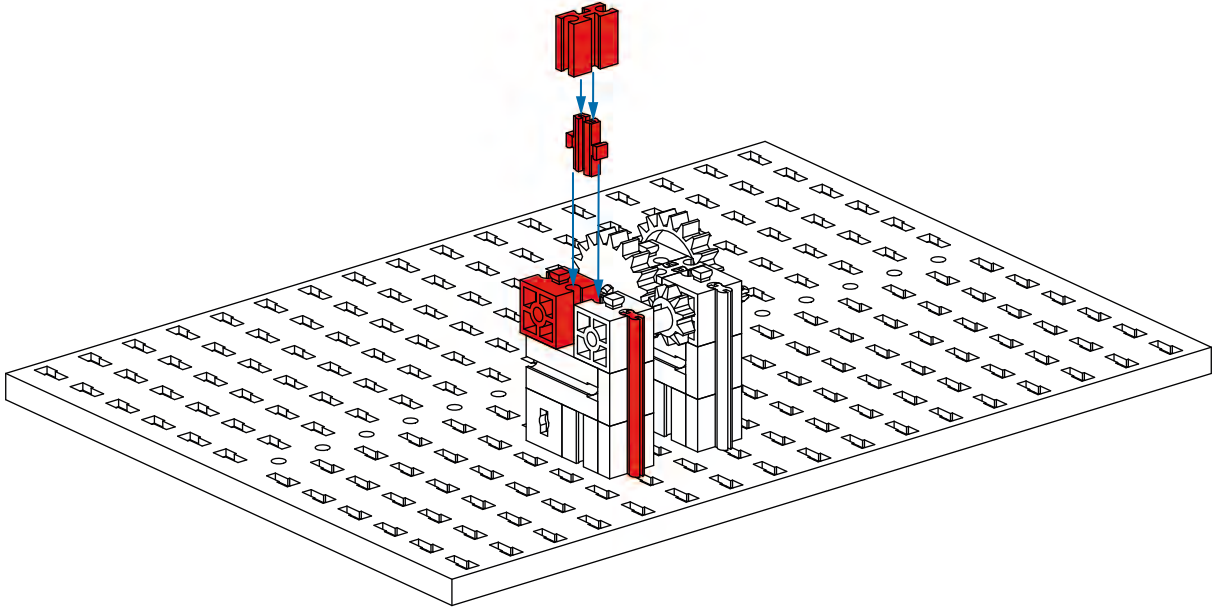

6

- 30 2 x
- 1 x
- 1 x

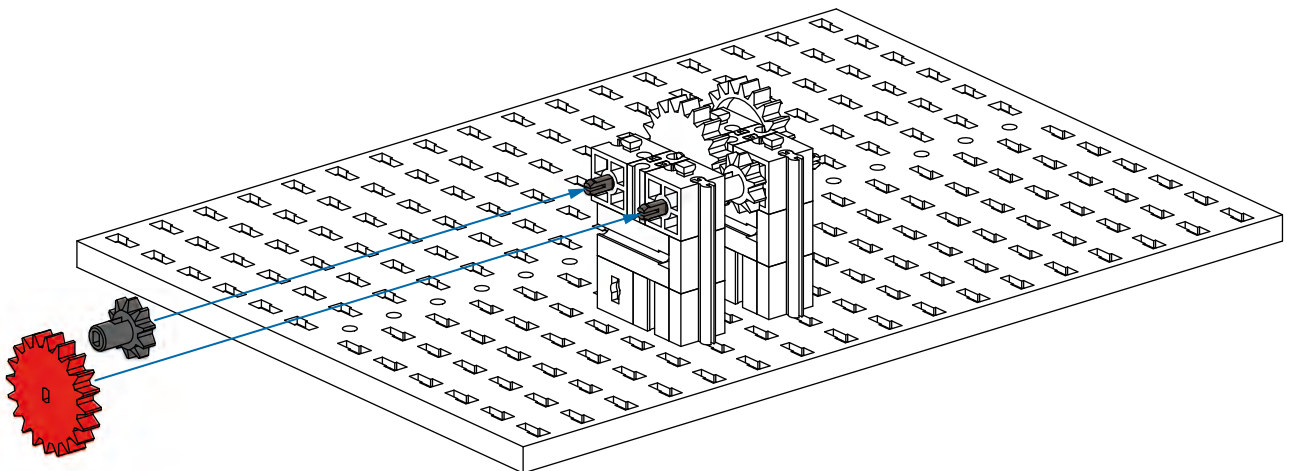
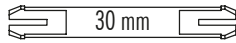

- 7**
- 1x [Grey Technic Pin]
 - 1x [Red Technic Pin]
 - 1x [Grey Technic Connector]
 - 1x [Red Technic Connector]

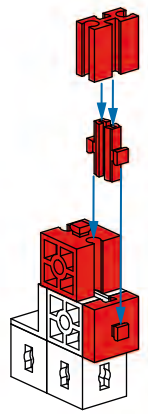
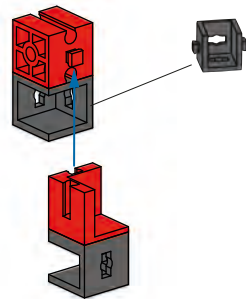

- 8**
- 1x [Red Technic Pin]
 - 2x [Red Technic Pin]
 - 1x [Red Technic Connector]
 - 1x [Red Technic Connector]

- 9**
- 1x [Grey Technic Pin]
 - 1x [Red Technic Pin]
 - 1x [Grey Technic Connector]
 - 1x [Grey Technic Connector]



8

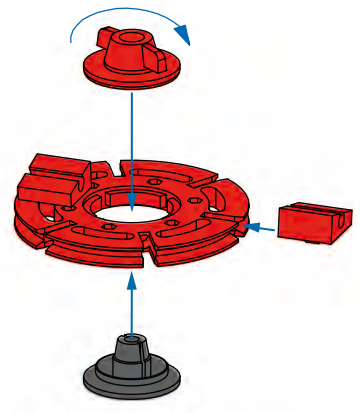
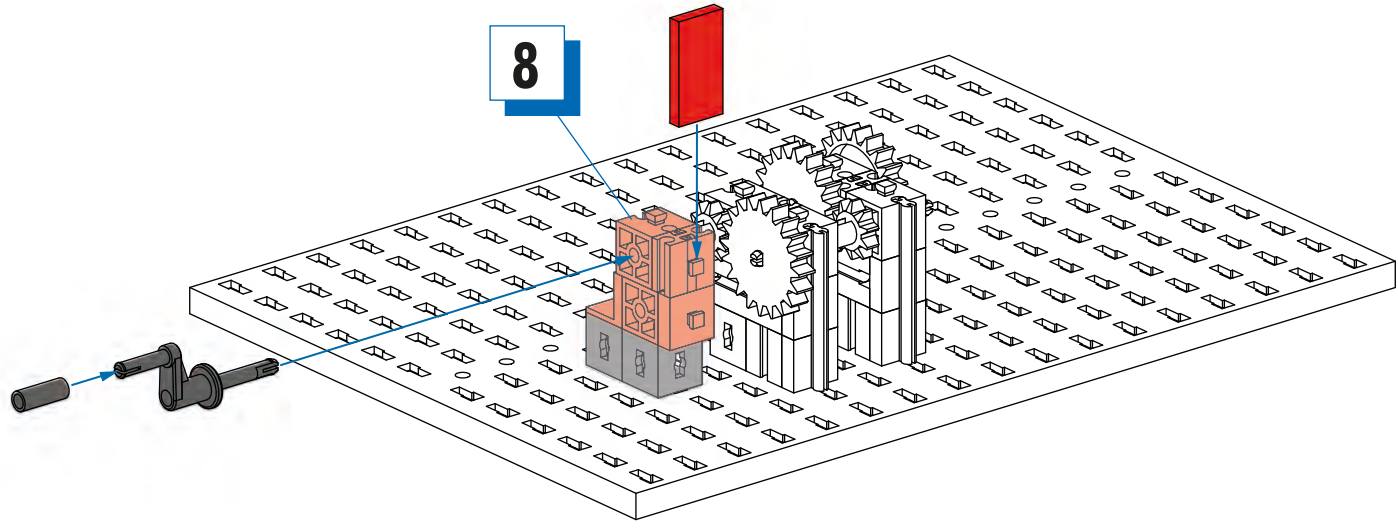

- 10**
- 1x [Red Technic Pin]
 - 1x [Grey Technic Pin]
 - 1x [Red Technic Ring]
 - 2x [Red Technic Pin]

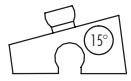

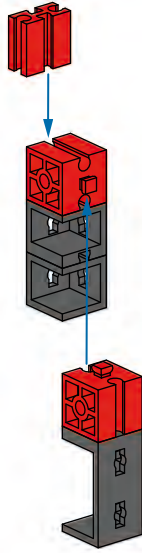

- 11**
- 1x Grey Technic Brick
 - 1x Grey Technic Brick
 - 2x Red Technic Brick
 - 1x Red Technic Brick
 - 1x Grey Technic Brick

- 12**
- 1x Red Technic Brick
 - 4x Red Technic Brick
 - 1x Red Technic Brick
 - 1x Grey Technic Brick

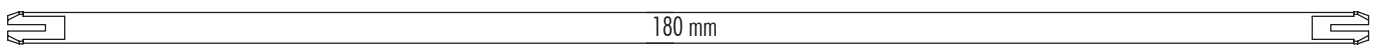
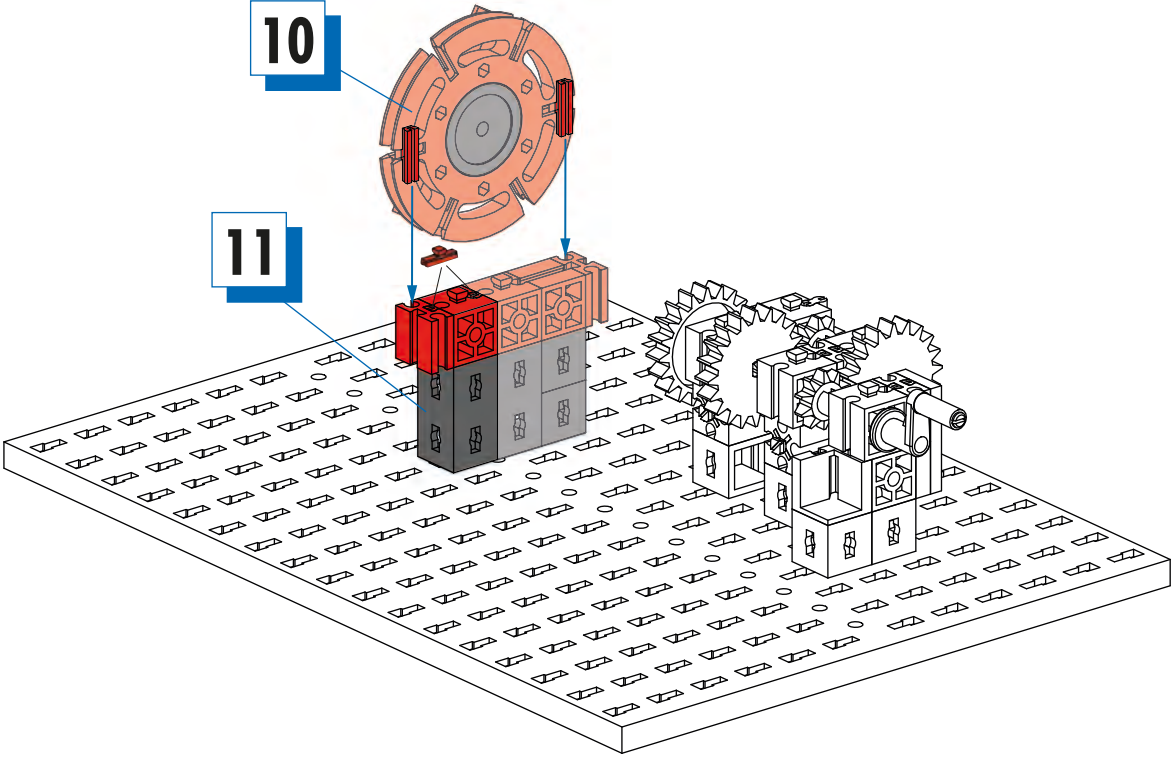



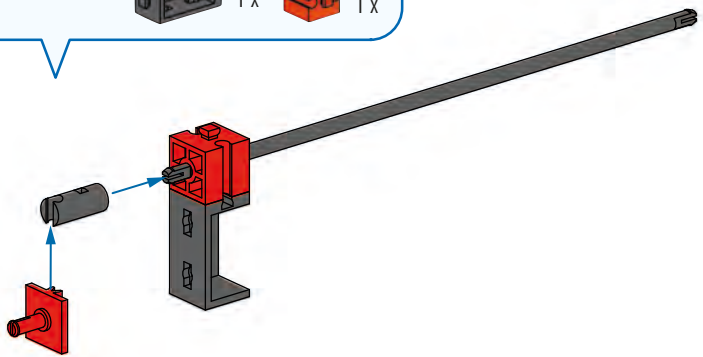

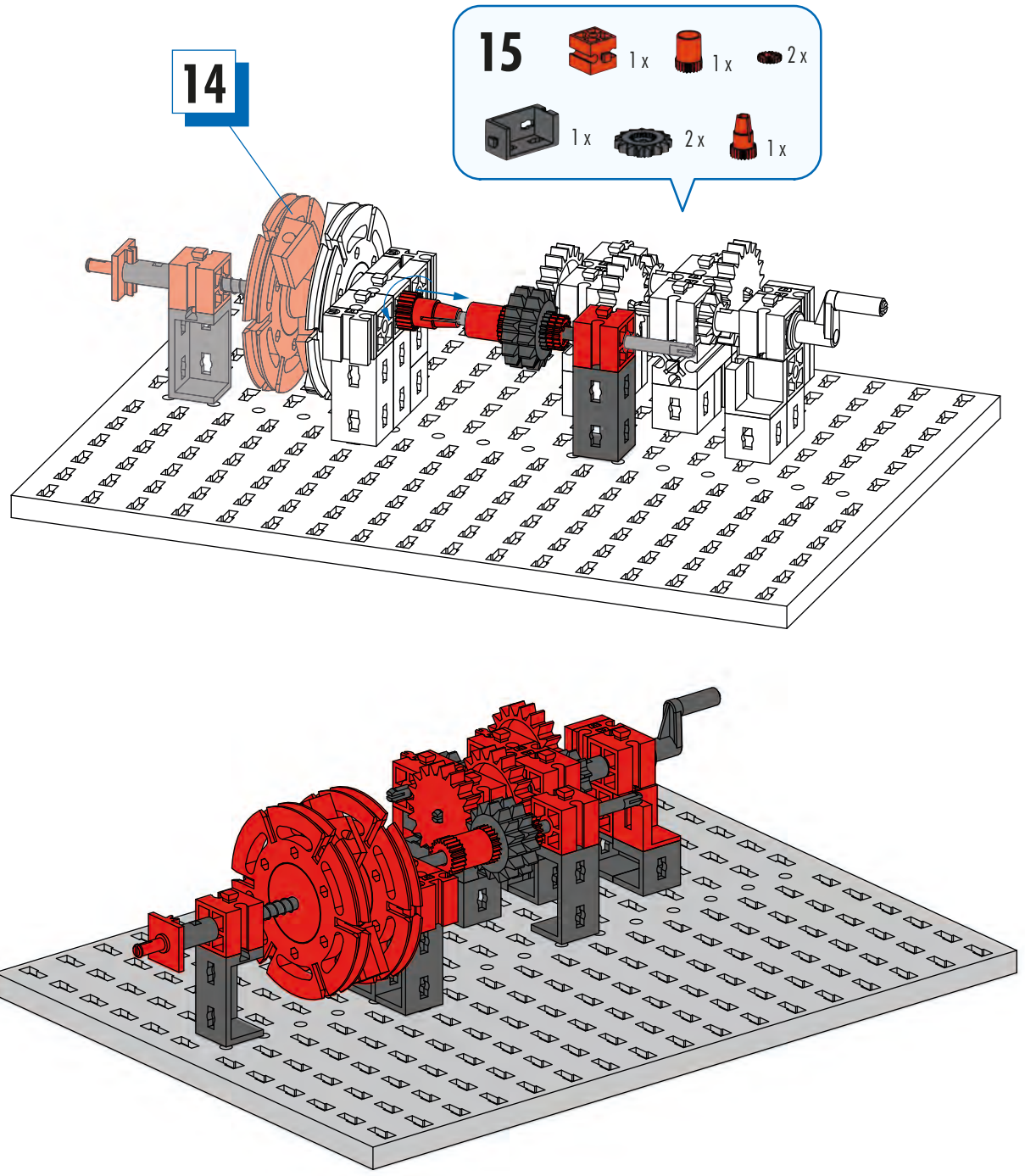
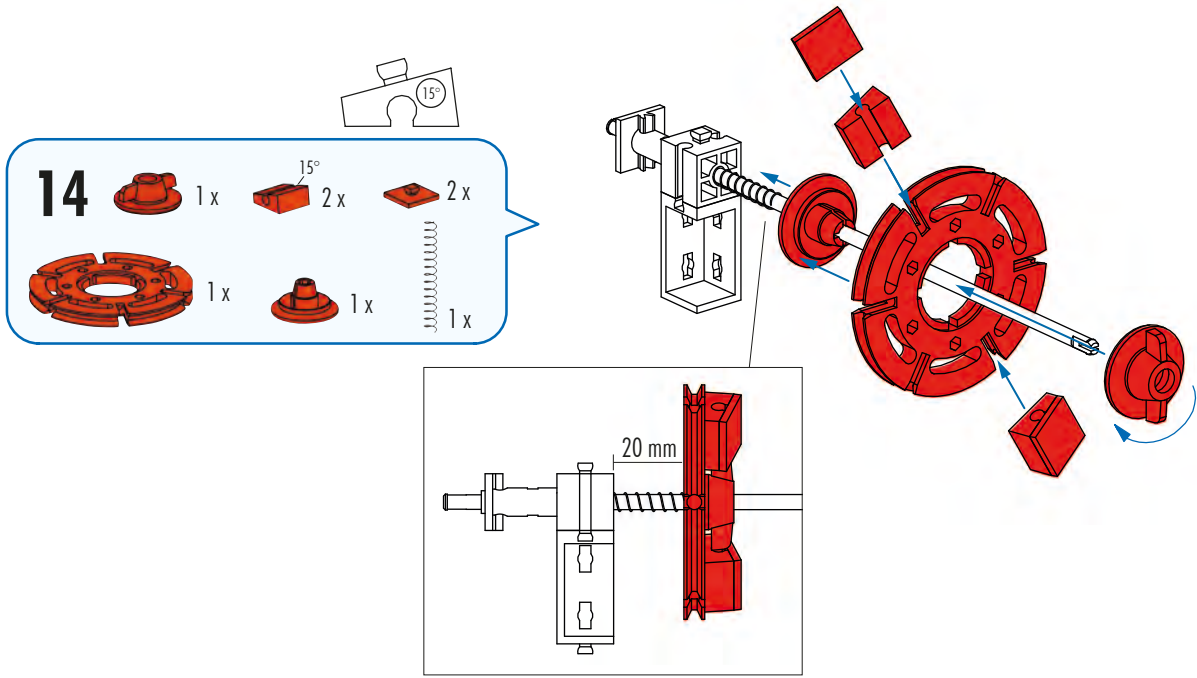
- 13**
- 1x Grey Technic Pin
 - 1x Grey Technic Axle (180)
 - 1x Red Technic Pin
 - 1x Grey Technic Brick
 - 1x Red Technic Brick



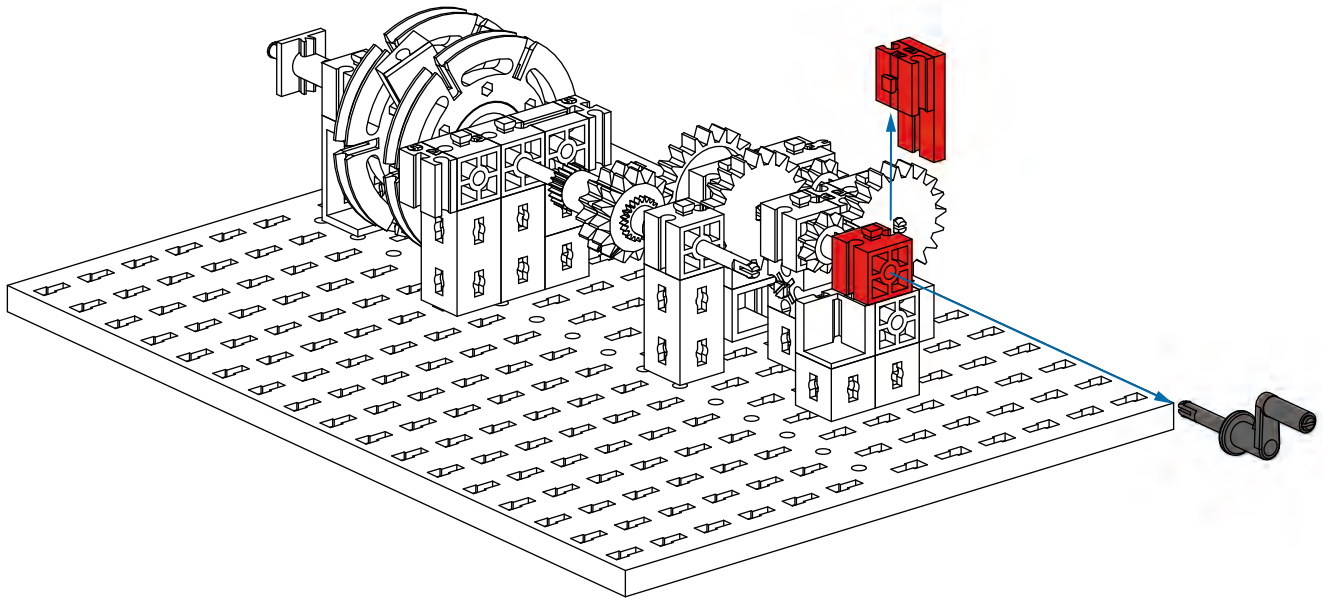

1 X



2  1x  1x
 1x  1x

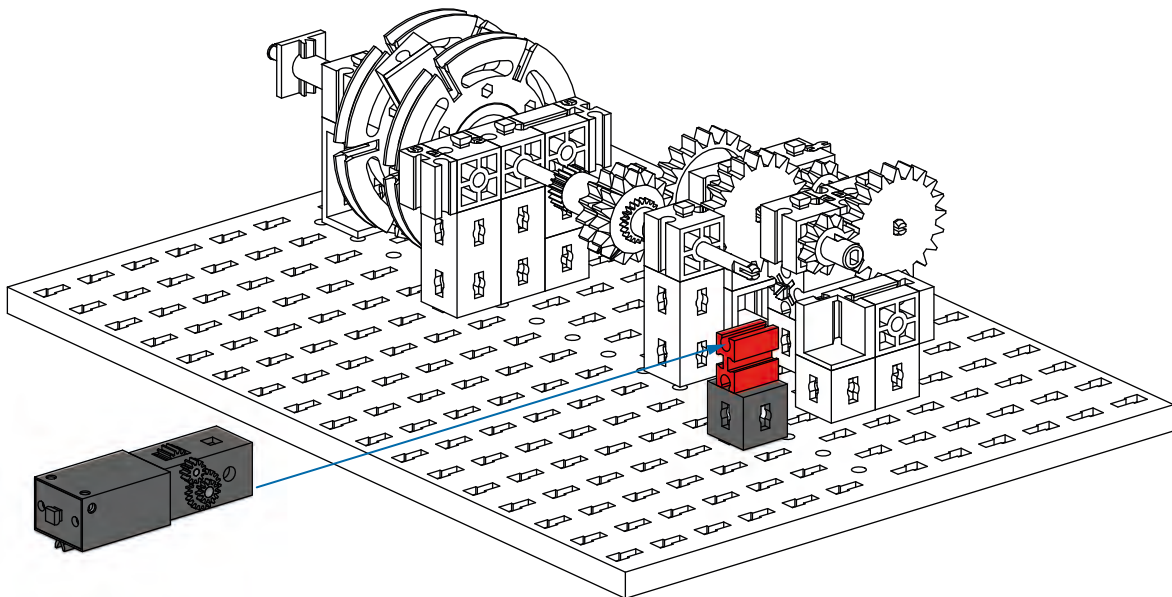

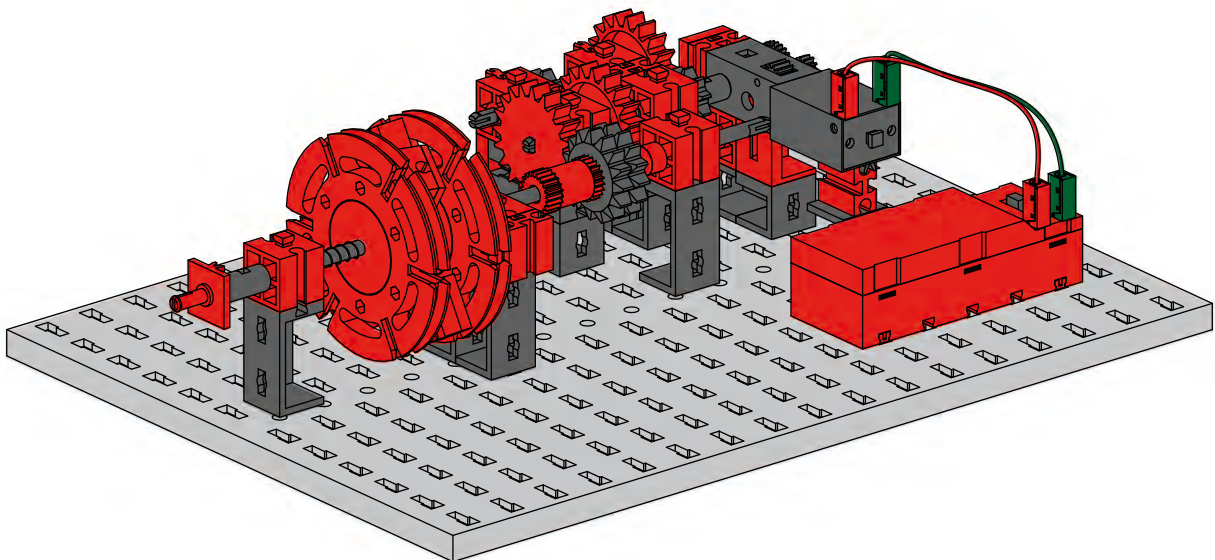
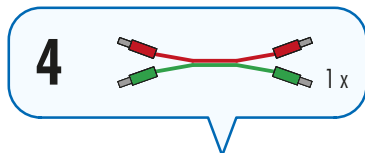
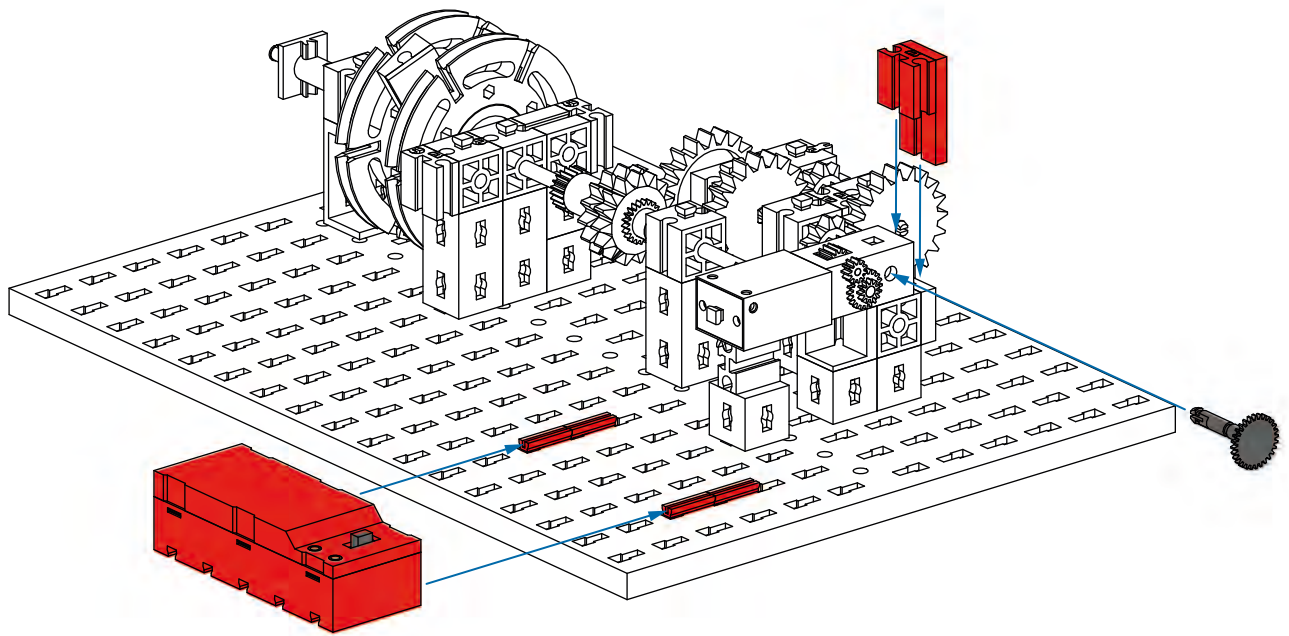
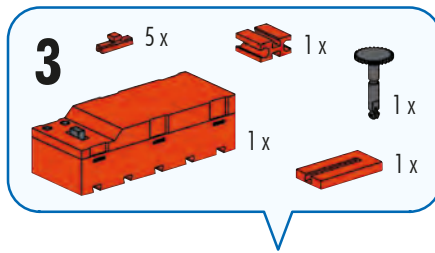

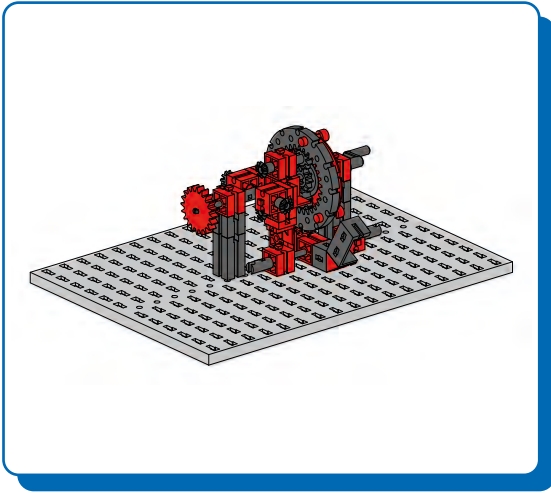



Planetengetriebe
Planetary gear
Réducteur planétaire

Planetair tandwiel
Engranaje planetario
Engrenagem planetária



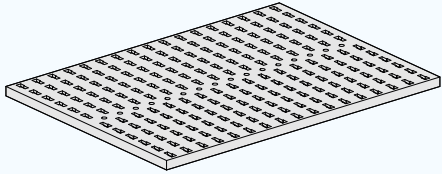

Ingranaggio planetario
Планетарная передача
行星齿轮

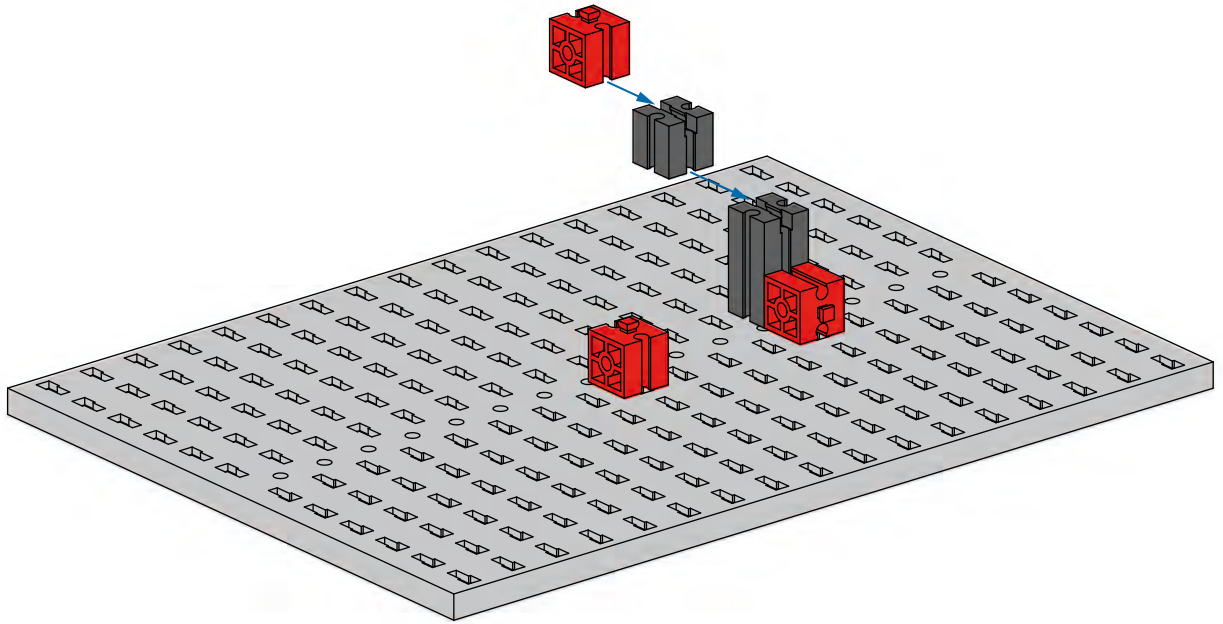
1

 1x
 1x
 3x
 1x



2

 1x
 2x
 1x
 1x
 1x

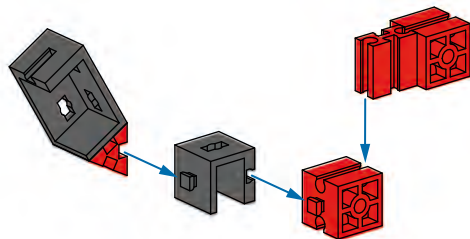

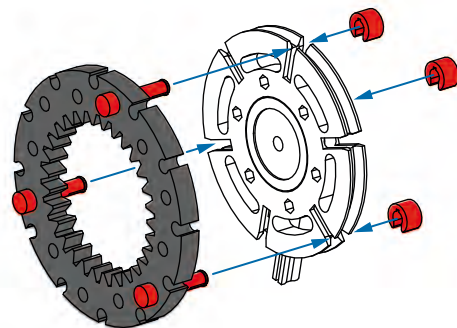
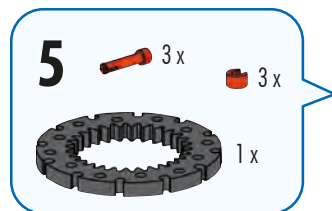
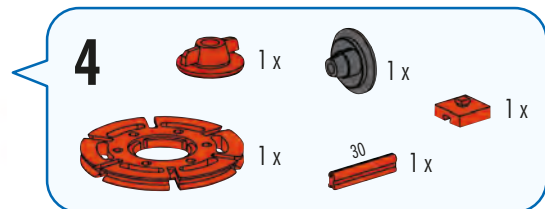
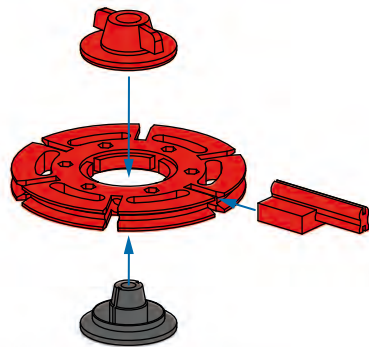
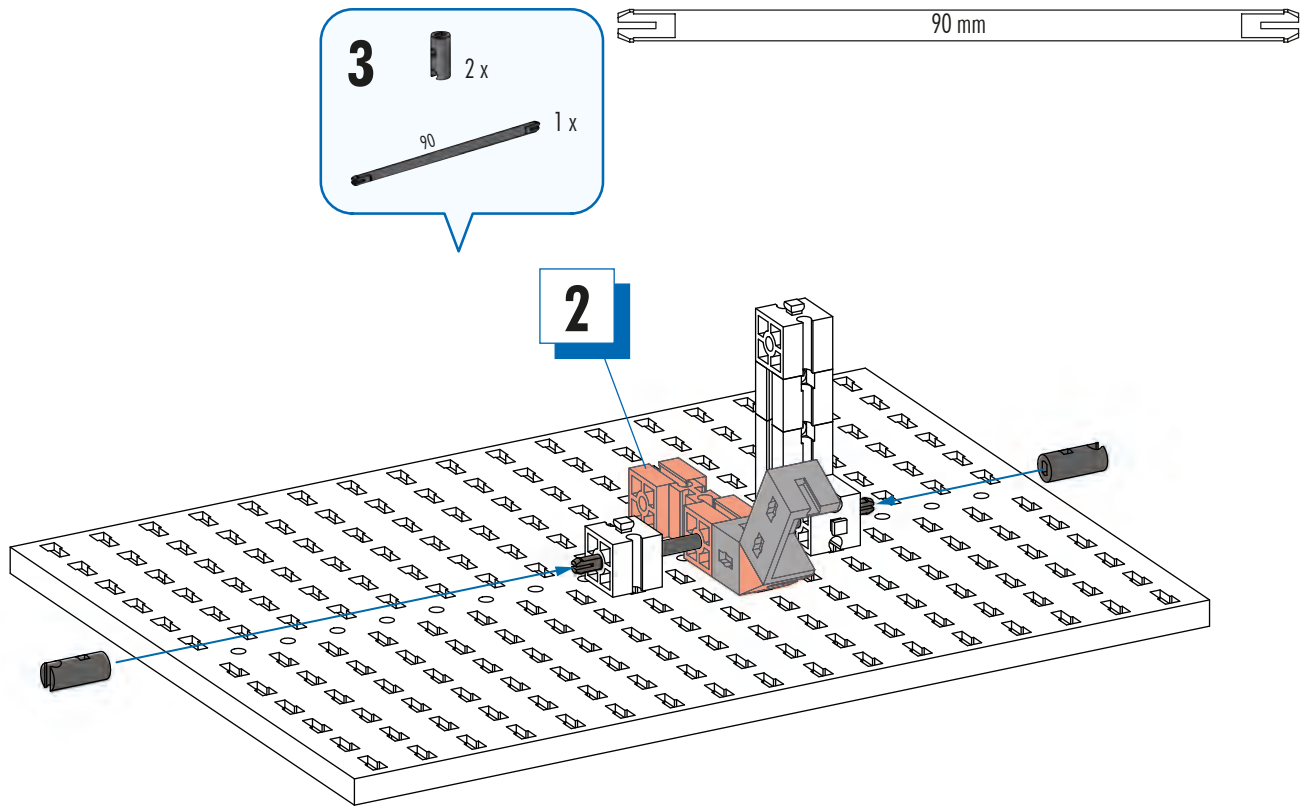

45 mm

- 6**
- 1 x [Red Pin]
 - 1 x [Grey Pin]
 - 1 x [Grey Technic Axle]
 - 1 x [Grey Technic Axle]
 - 1 x [Red Technic Axle 45]
 - 1 x [Red Technic Axle 15]
 - 1 x [Grey Technic Axle 45]

5

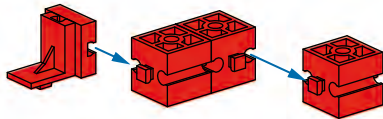
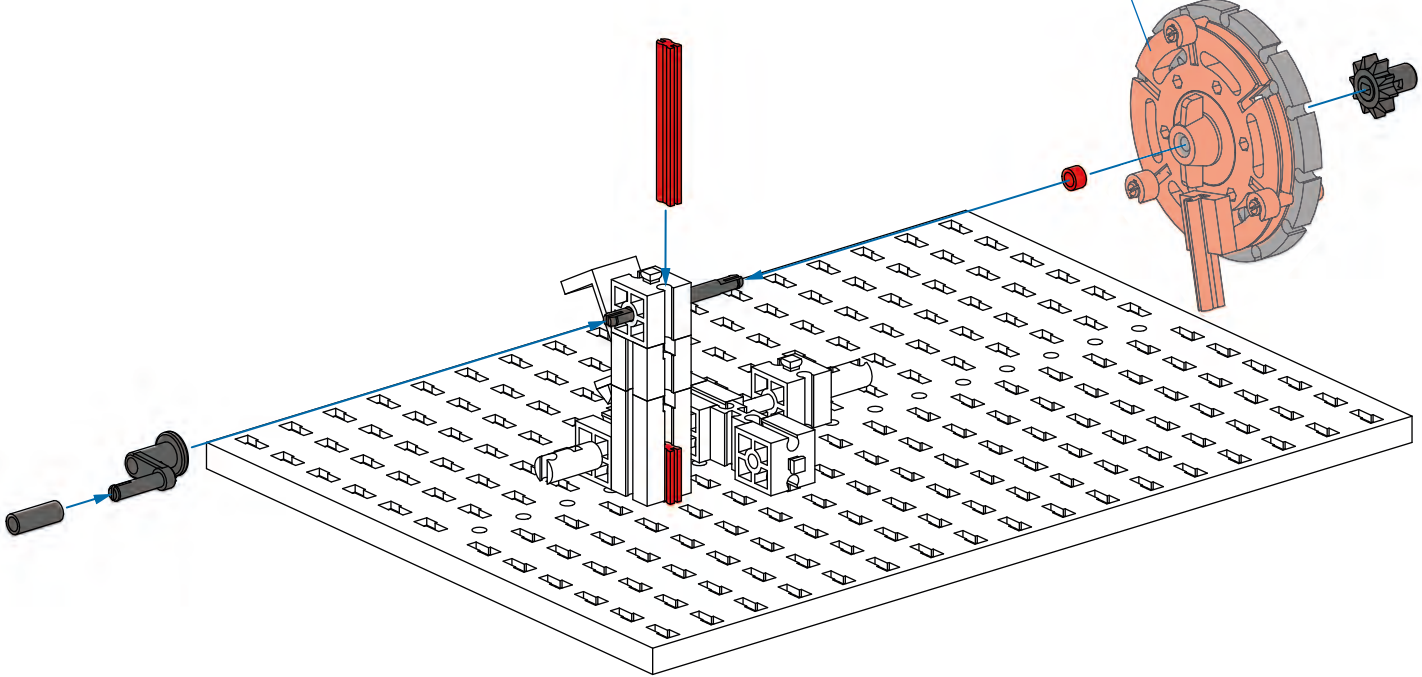

- 7**
- 3 x [Red Technic Brick 1x3]
 - 1 x [Red Technic Brick 1x2]
 - 1 x [Red Technic Brick 1x3]

- 8**
- 1 x [Red Technic Brick 1x3]
 - 1 x [Red Technic Brick 1x2]
 - 1 x [Red Technic Brick 1x3]
 - 1 x [Red Technic Brick 1x3]
 - 1 x [Grey Technic Axle]
 - 1 x [Grey Technic Axle]
 - 1 x [Grey Technic Axle 30]

30 mm

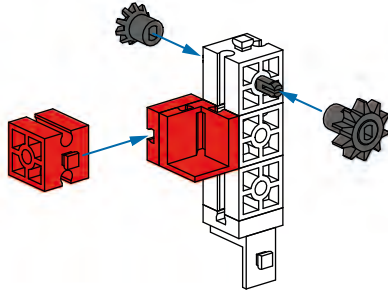

9

- 1x [red 1x2 Technic brick]
- 1x [black 1x2 Technic pin]
- 1x [red L-shaped Technic Technic brick]
- 1x [black 1x2 Technic pin]
- 1x [black 30mm Technic axle]

30 mm

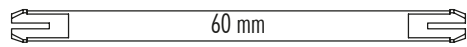
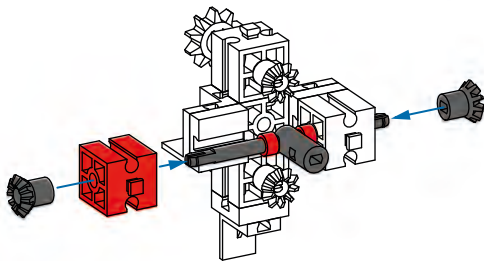
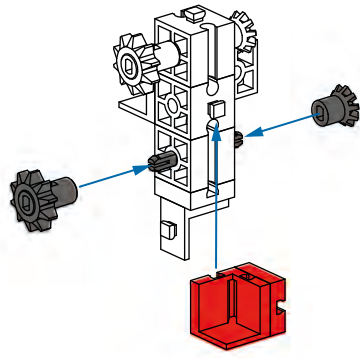

10

- 2x [red 1x2 Technic brick]
- 1x [black 1x2 Technic pin]
- 2x [black 1x2 Technic pin]
- 1x [red 1x2 Technic brick]
- 1x [black 60mm Technic axle]



11

- 1x [black 30mm Technic axle]

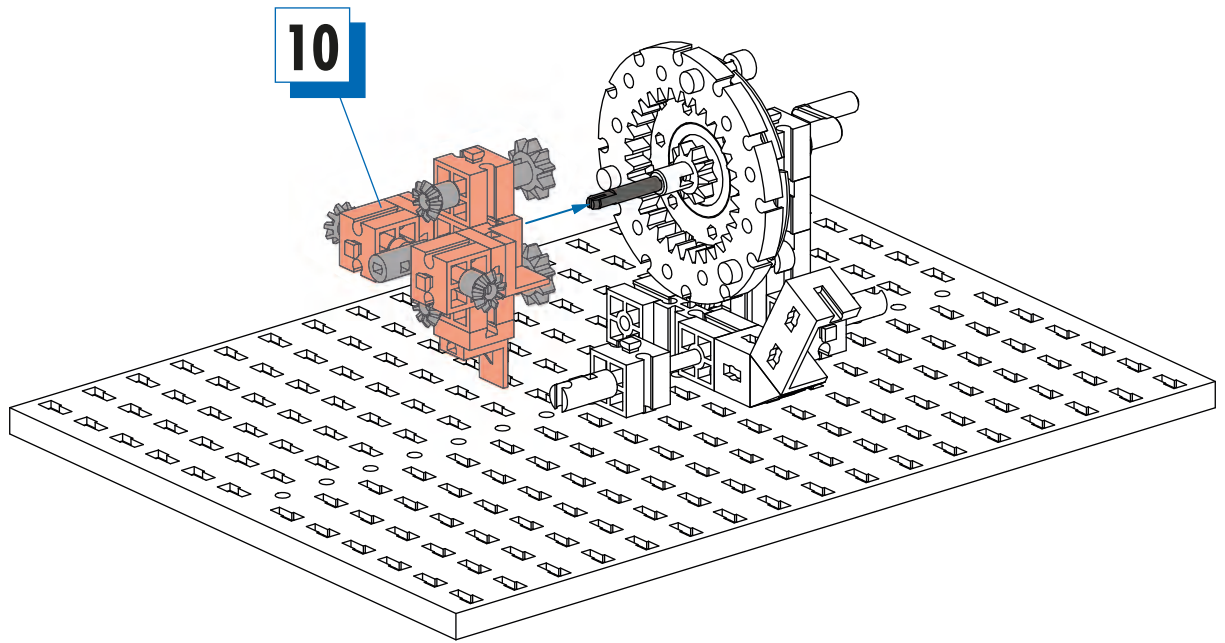

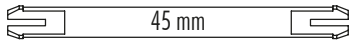

12



1x



1x



1x

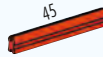

1x



1x



1x



1x

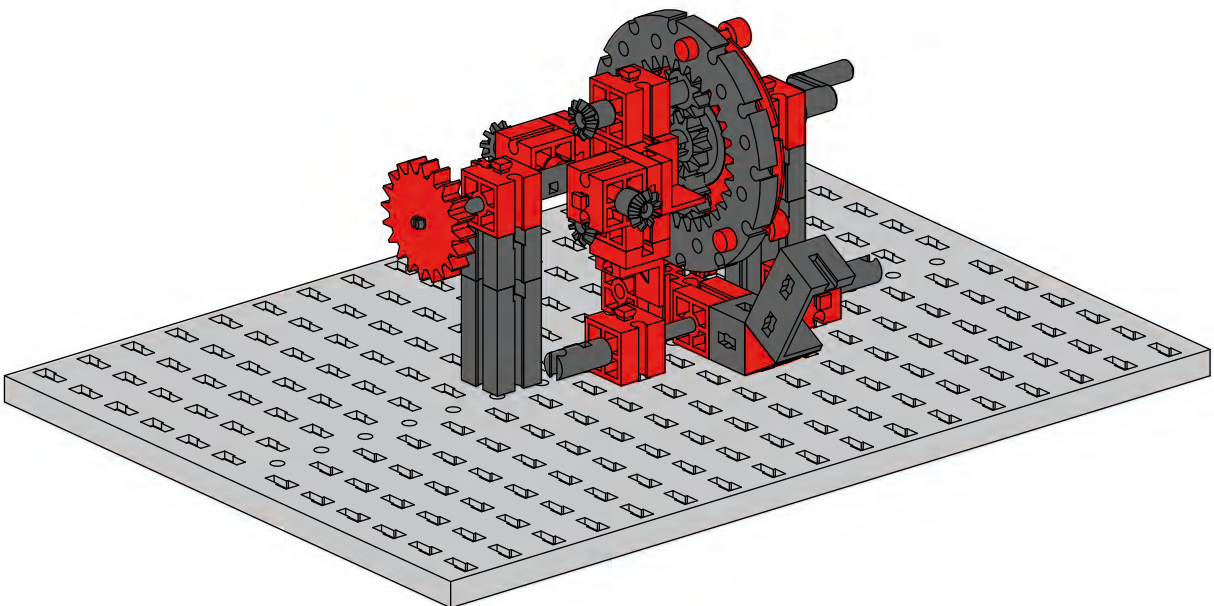
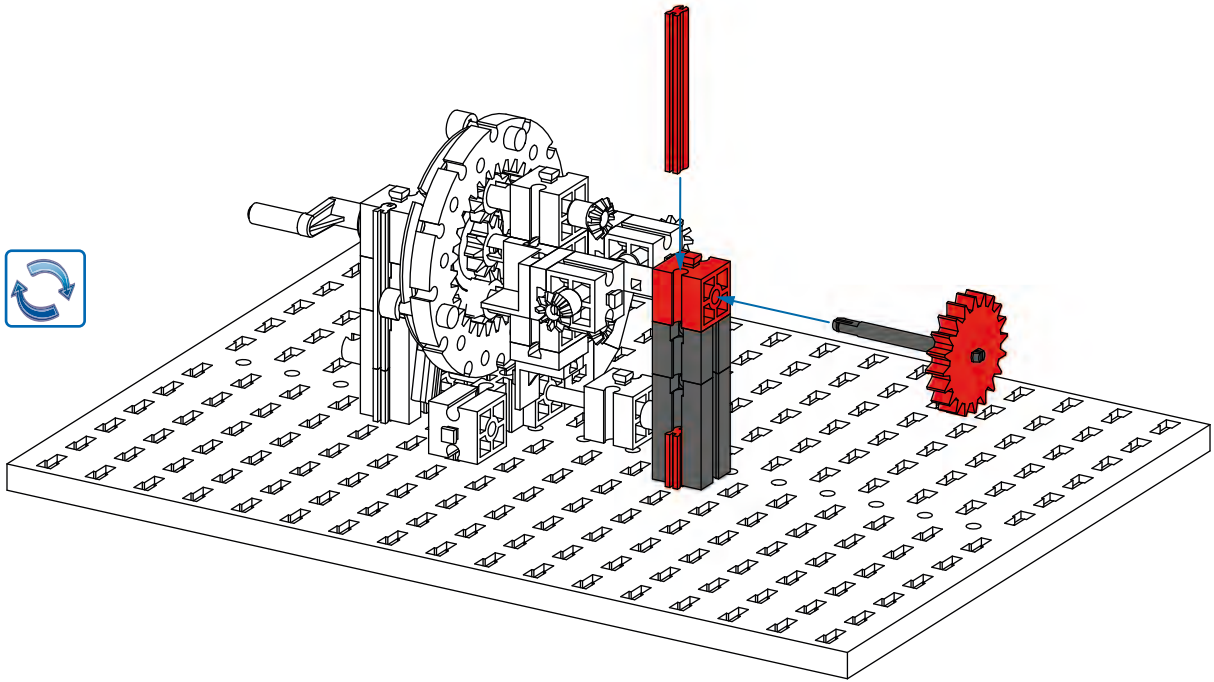

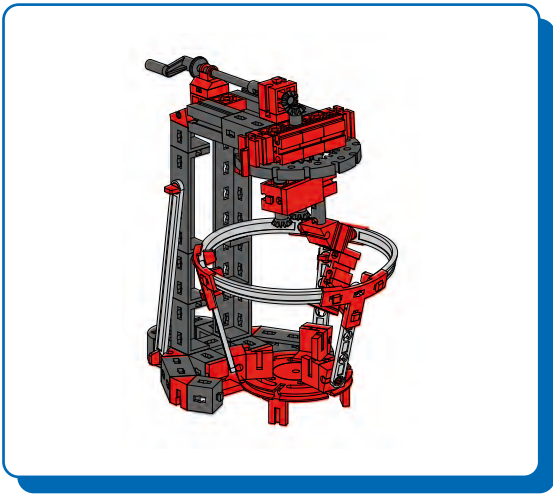

Küchenmaschine
Food Processor
Robot ménager

Keukenmachine
Aparato de cocina
Batedeira de cozinha

Robot da cucina
Кухонный комбайн
电动厨具

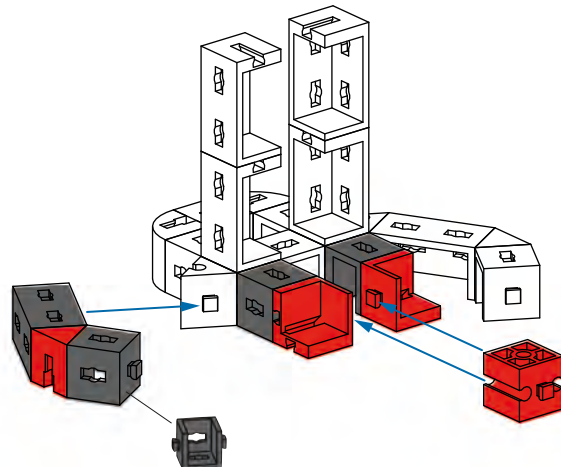
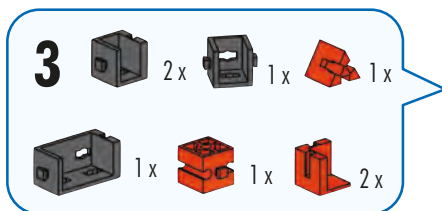
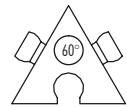
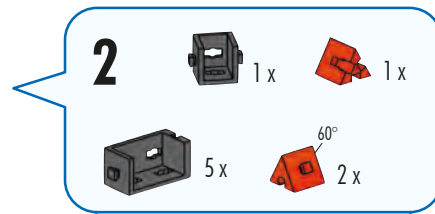
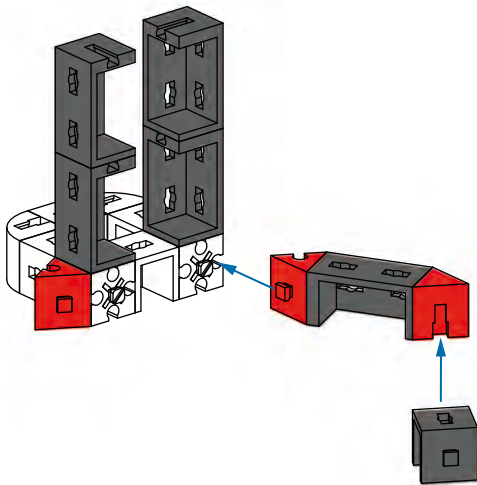
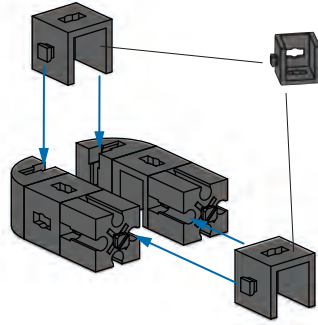
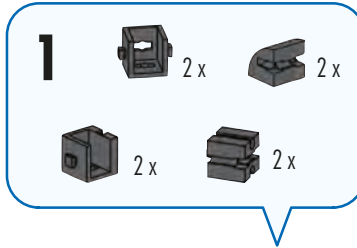

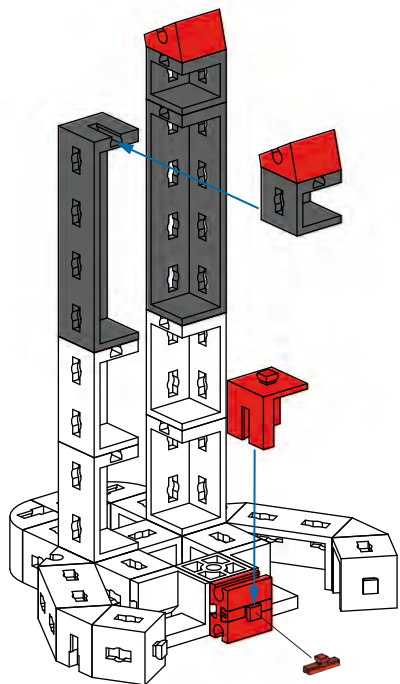

4

- 2x [Grey 1x3 Technic Beam]
- 1x [Red 1x2 Technic Beam]
- 1x [Red 1x2 Technic Beam]
- 1x [Red 1x2 Technic Beam]
- 2x [Grey 1x3 Technic Beam]
- 2x [Red 30° Technic Wedge]
- 1x [Red 1x2 Technic Beam]

5

- 2x [Red 1x2 Technic Beam]
- 2x [Grey 1x3 Technic Beam]
- 1x [Grey 1x3 Technic Beam]

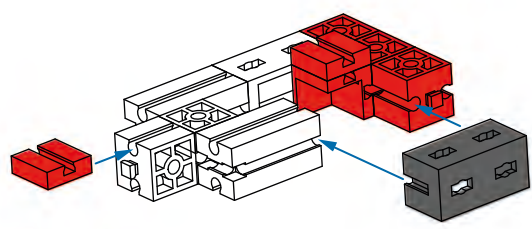
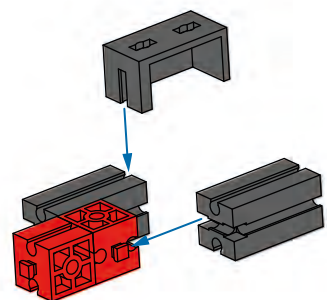

6

- 2x [Red 1x2 Technic Beam]
- 1x [Red 1x2 Technic Beam]
- 1x [Grey 1x3 Technic Beam]
- 3x [Red 1x2 Technic Beam]

7

- 5x [Red 1x2 Technic Beam]
- 1x [Red 1x2 Technic Beam]
- 2x [Red 1x2 Technic Beam]
- 2x [Red 1x2 Technic Beam]
- 1x [Red 45° Technic Wedge]

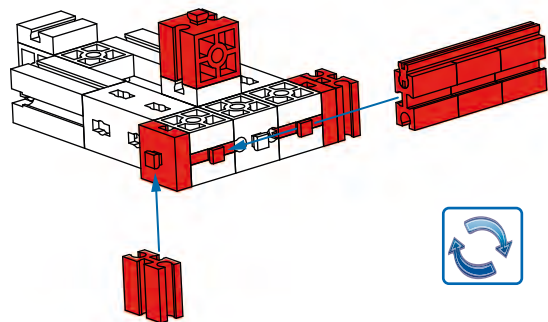

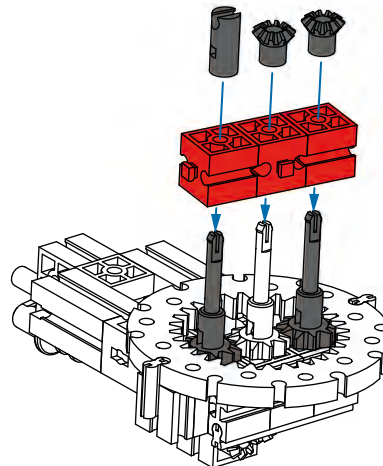
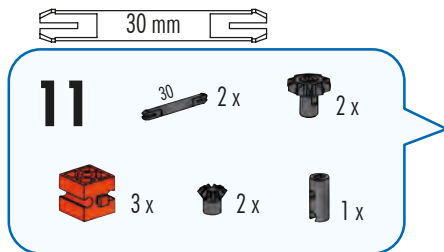
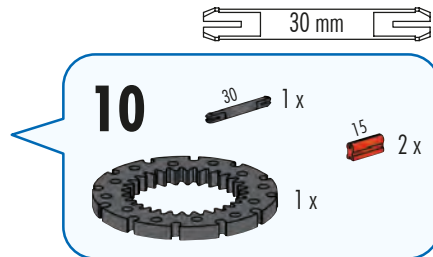
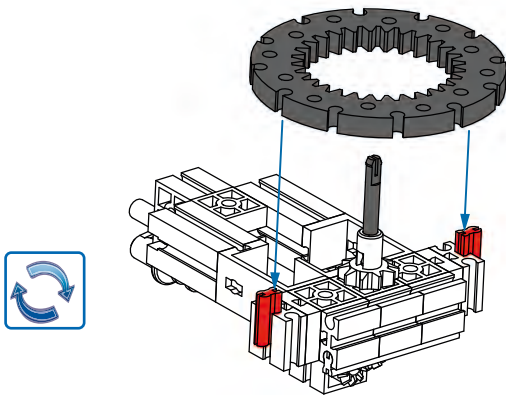
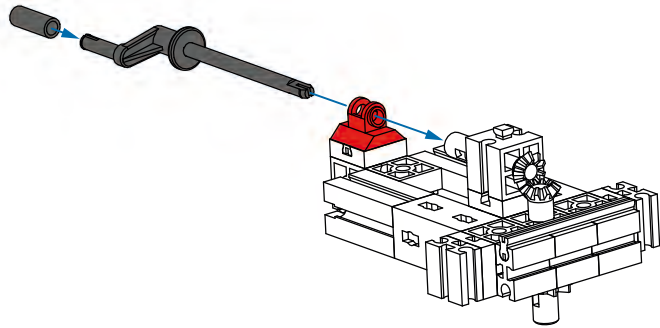
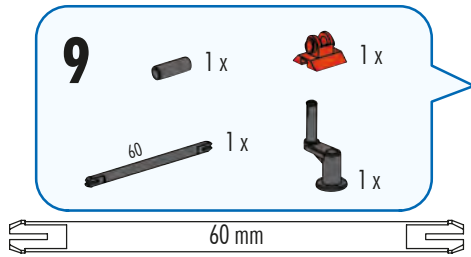
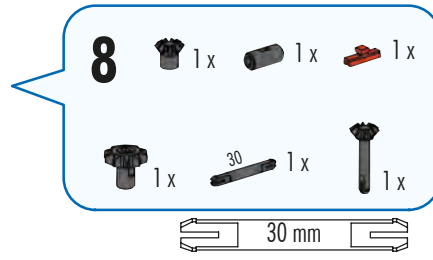
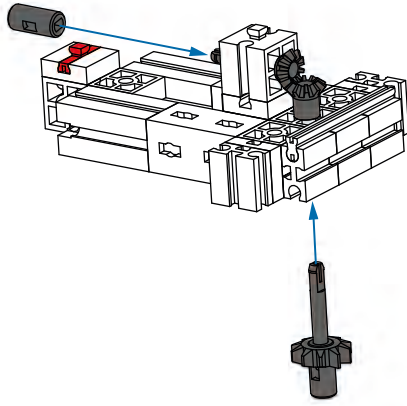

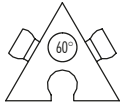

12

- 30 1x
- 15 1x
- 2x
- 1x
- 3x
- 60° 1x
- 1x

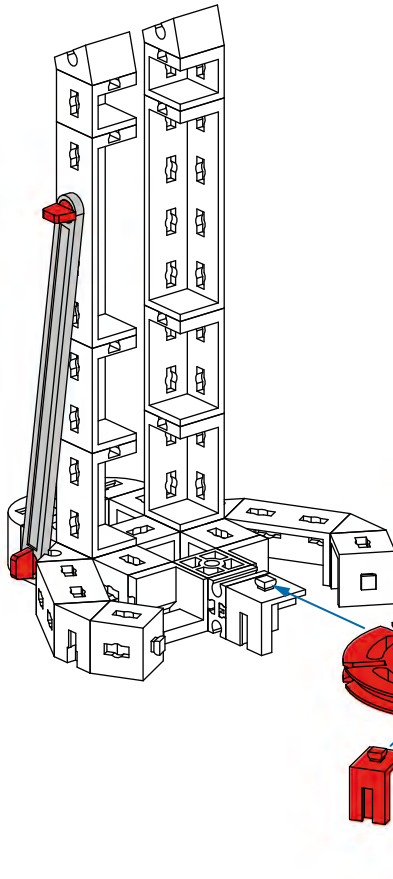
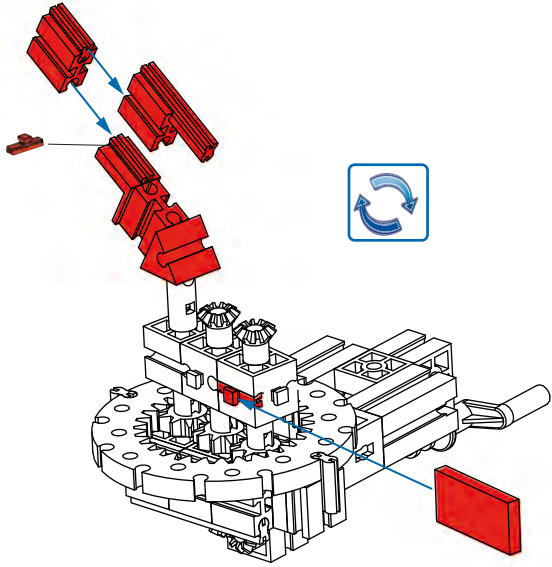

13

- 1x
- 1x
- 2x
- 2x
- 1x
- 106 1x

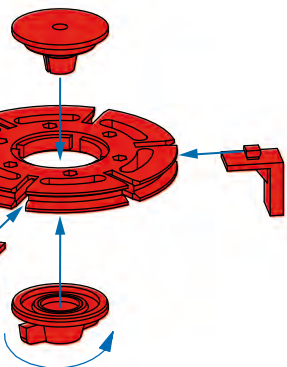
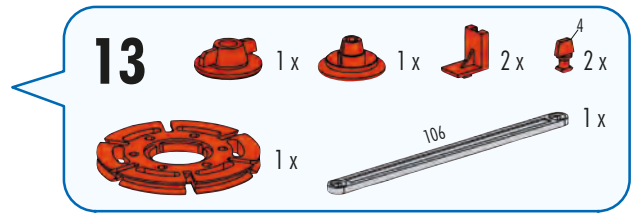

14

- 3x
- 15° 3x
- 3x
- 2x
- 60 3x
- 106 1x

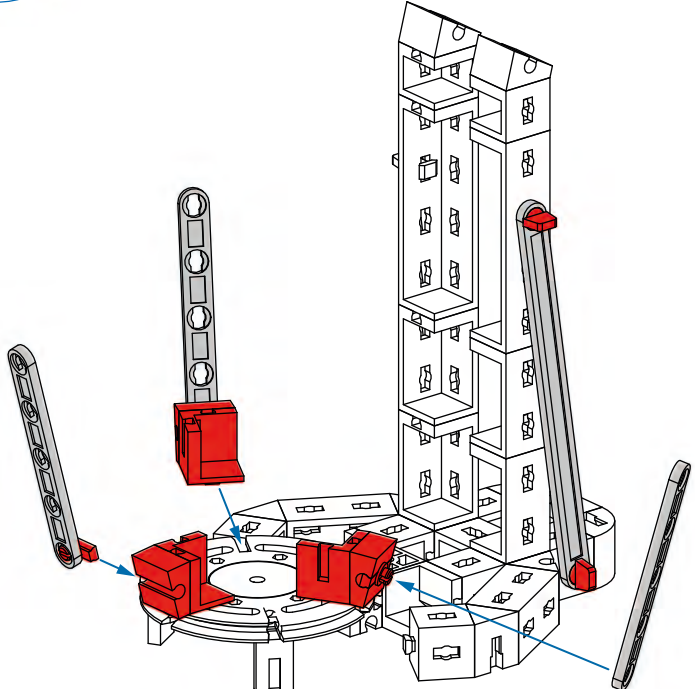
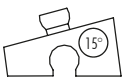

15

3x

3x

5x

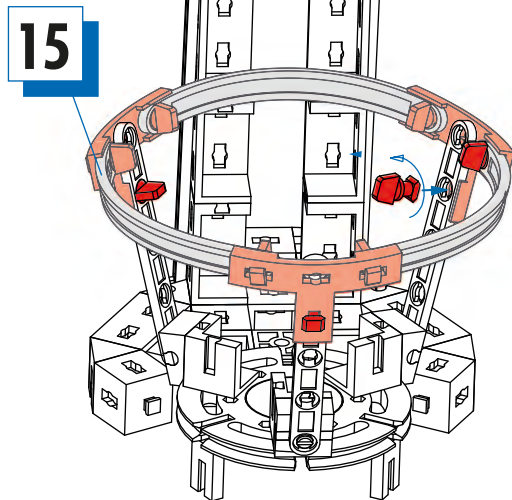
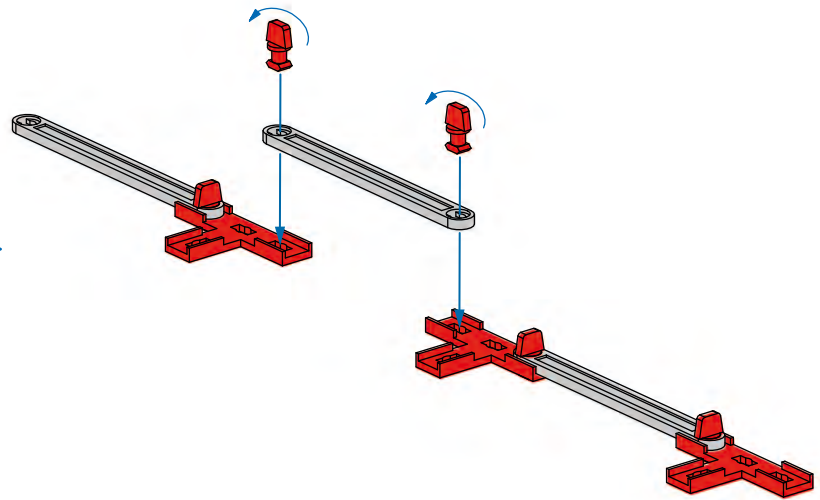

16

4x

12

45 mm

- 17 45 1x
- 1x
- 1x

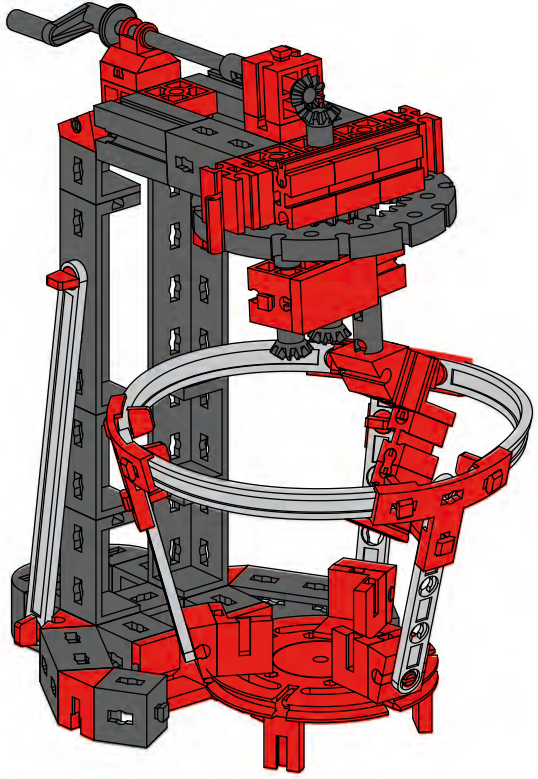
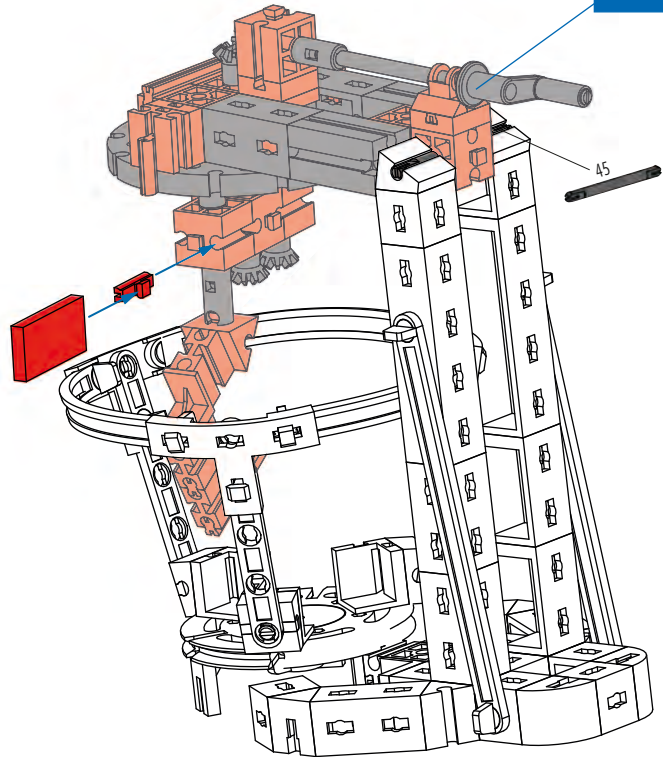

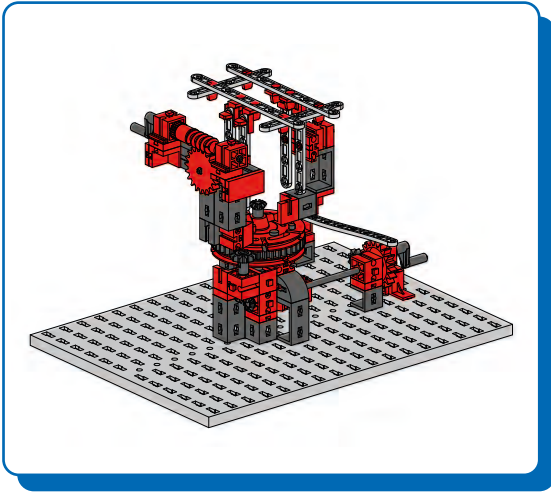

Solartracker
Solar Tracker
Traceur solaire

Zonne tracker
Seguidor solar
Rastreador solar

Inseguitore solare
Солнечный трекер
太阳能跟踪器

1

- 2x [Grey Technic Pin]
- 3x [Red Technic Pin]
- 1x [Grey Technic Bracket]
- 1x [Red Technic Bracket]
- 1x [Grey Technic Base Plate]

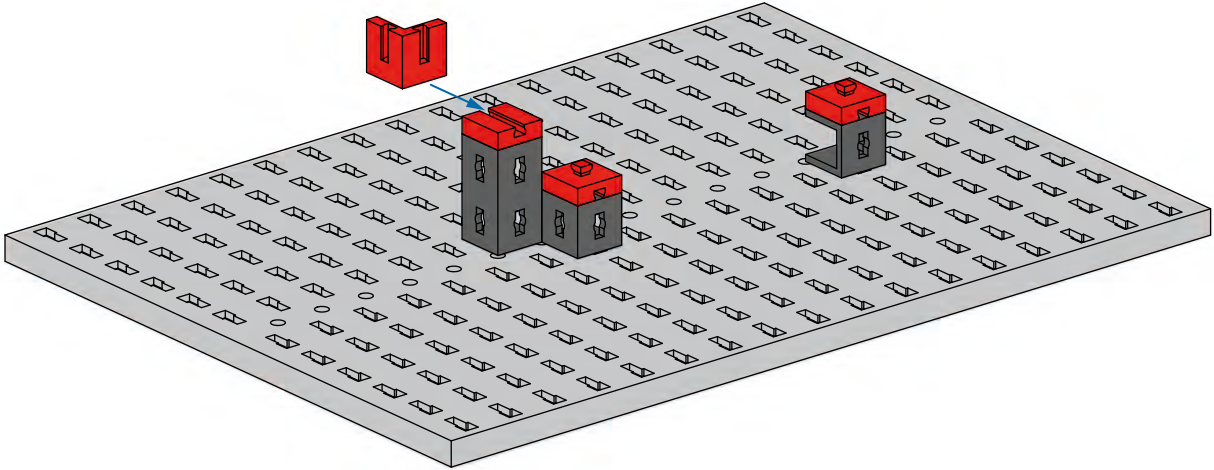

2

- 1x [Grey Technic Pin]
- 1x [Grey Technic Pin]
- 1x [Red Technic Pin]
- 1x [Red Technic Bracket]
- 1x [Red Technic Bracket]
- 2x [Red Technic Pin]

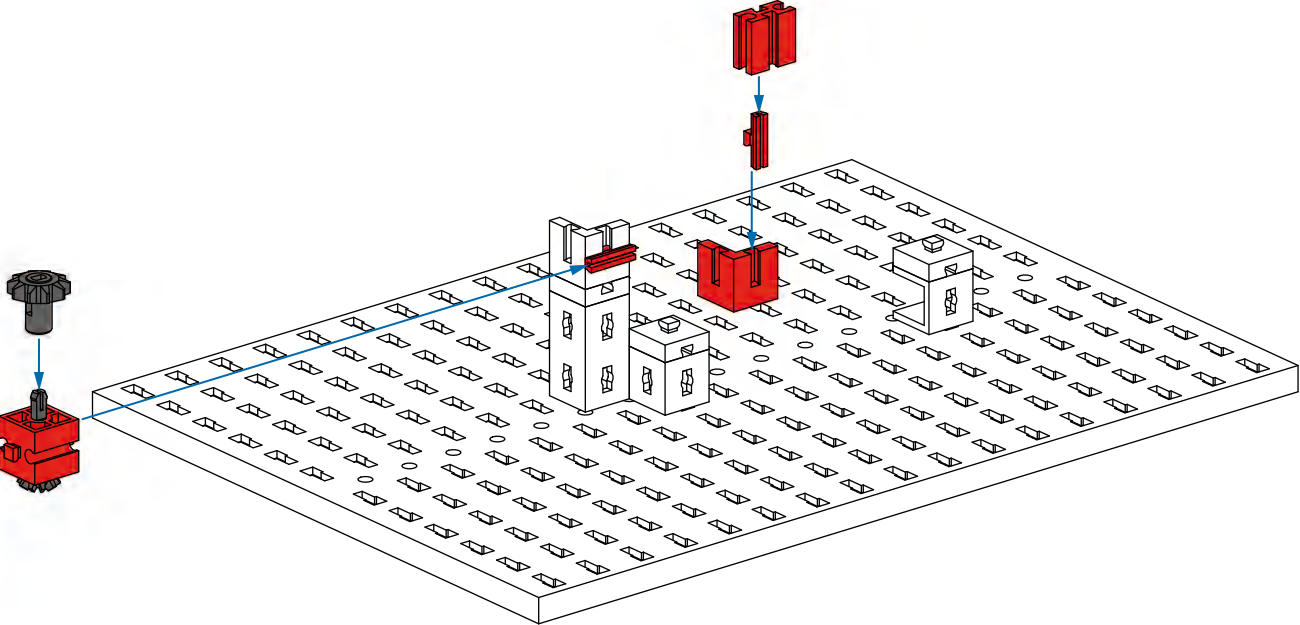

3

- 1x Red 1x2 Technic Brick with Hole
- 1x Black Technic Pin
- 1x Black Technic Pin
- 1x Red 1x2 Technic Brick with Hole
- 1x Red 1x2 Technic Brick with Hole
- 1x Red 1x2 Technic Brick with Hole
- 2x Red 1x2 Technic Brick with Hole

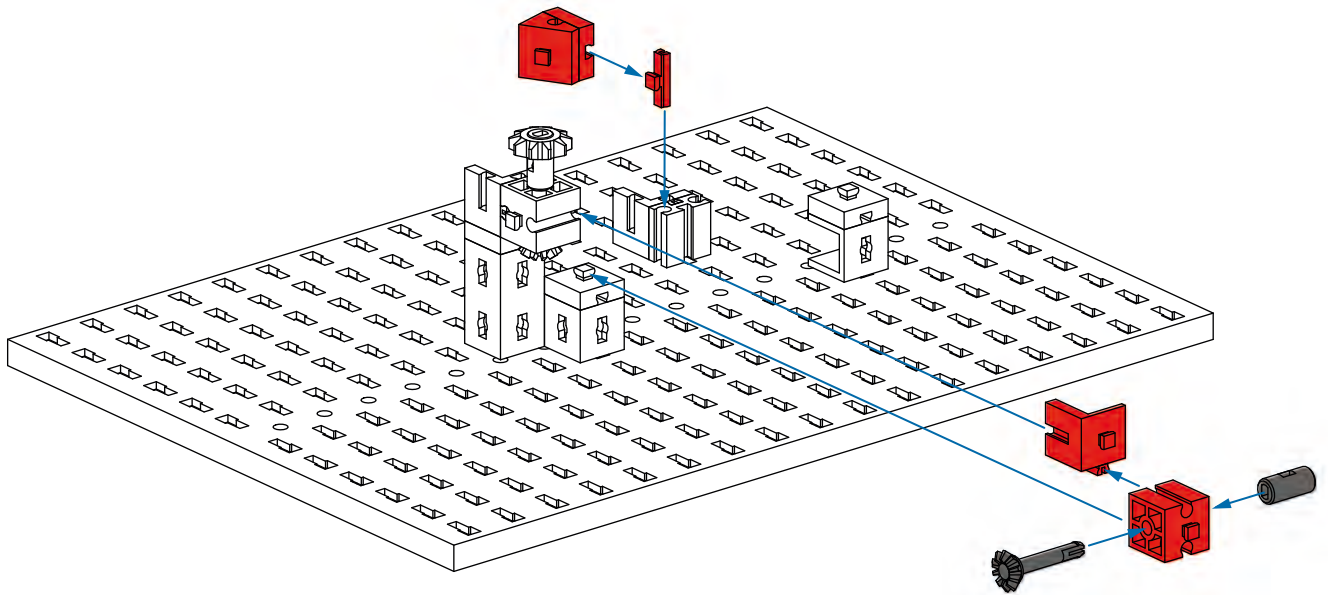

4

- 1x Grey Technic Pin
- 1x Red 1x2 Technic Brick with Hole
- 1x Red 1x2 Technic Brick with Hole
- 2x Grey Technic Pin
- 1x Grey Technic Pin
- 2x Red 1x2 Technic Brick with Hole

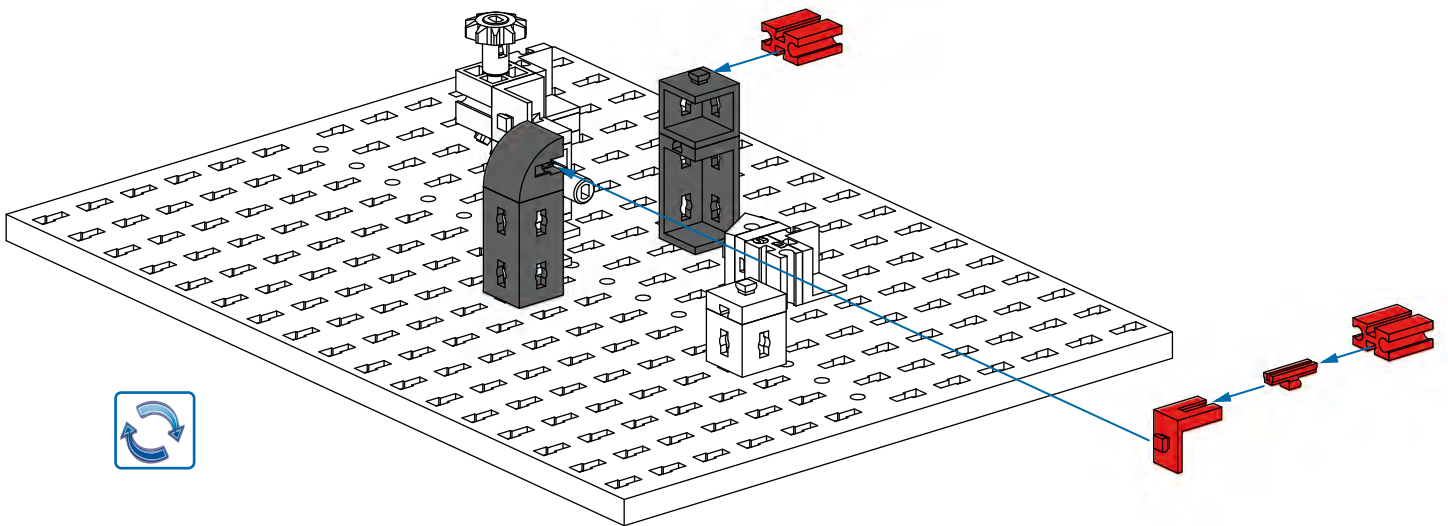

5

- 1x [Grey Technic Brick with 2 holes]
- 1x [Grey Technic Brick with 2 holes]
- 1x [Red Technic L-Shape]
- 1x [Red Technic 1x2 Plate]

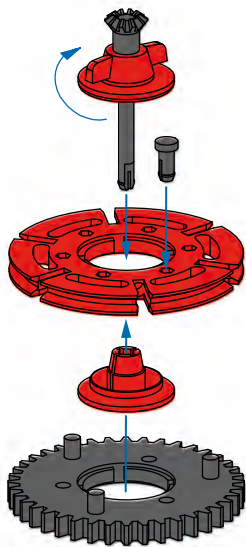
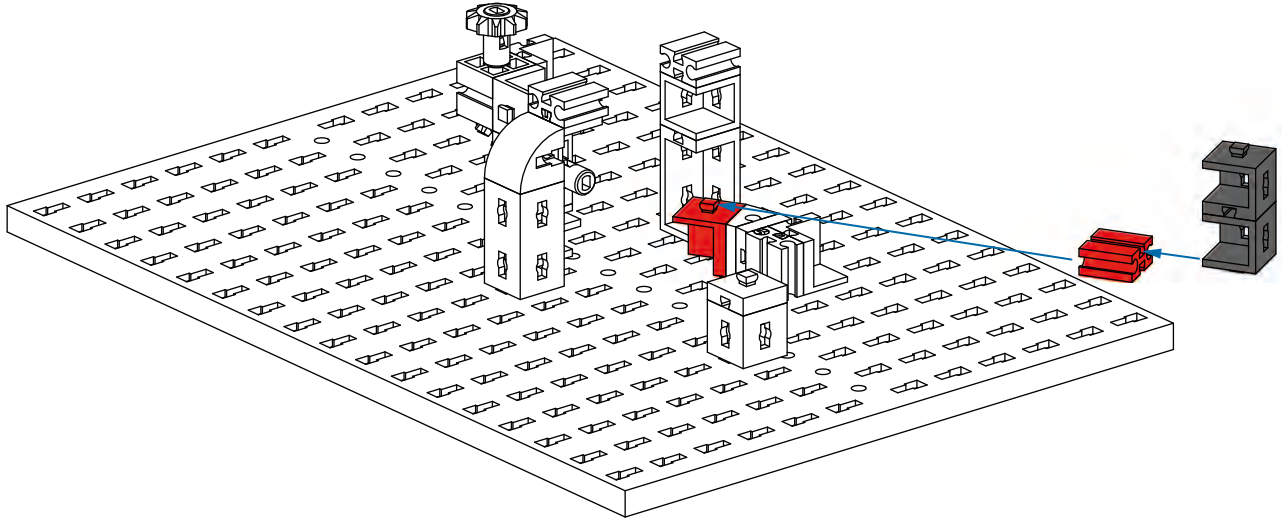

45 mm

6

- 1x [Red Technic Pin]
- 1x [Red Technic Pin]
- 1x [Red Technic Ring]
- 1x [Grey Gear]
- 1x [Grey Axle 45]
- 1x [Grey Pin]
- 1x [Grey Pin]

7

- 1x [Grey Pin]
- 1x [Grey Pin]
- 1x [Red Technic Ring]
- 1x [Red Technic Pin]

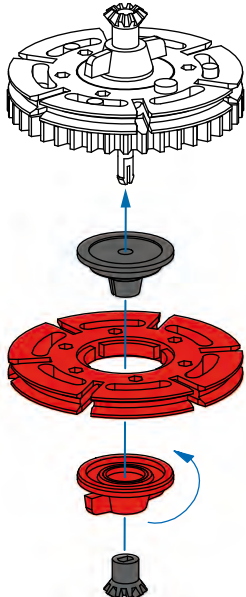

90 mm

- 8**
- 1x
 - 1x
 - 1x
 - 2x

7

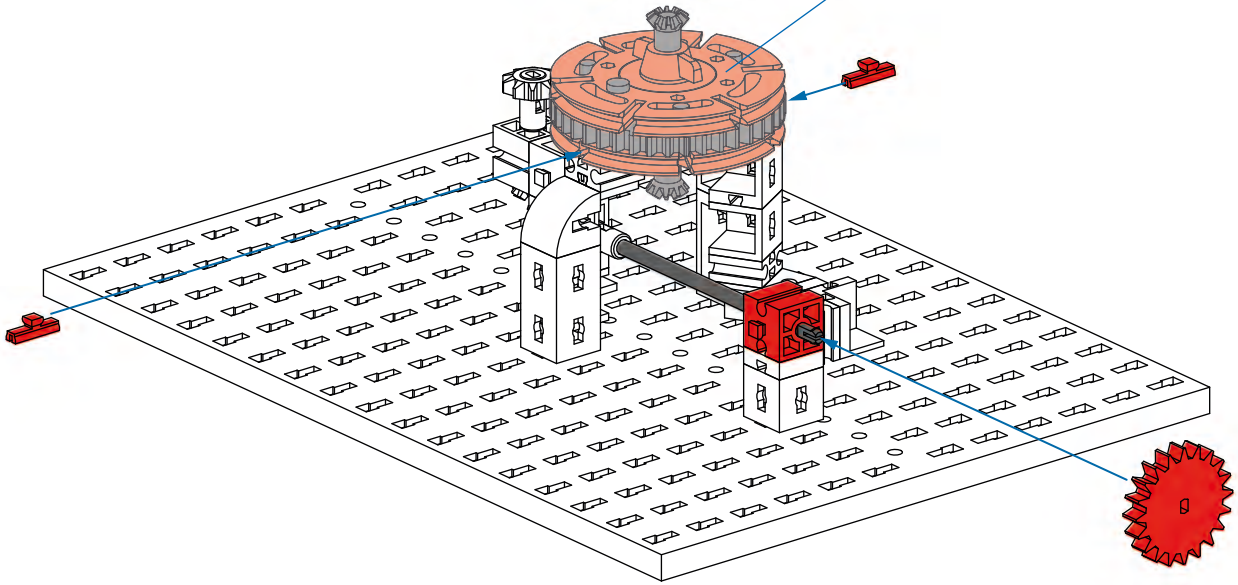

- 9**
- 1x
 - 1x
 - 1x
 - 1x
 - 2x
 - 1x
 - 1x
 - 2x
-
-

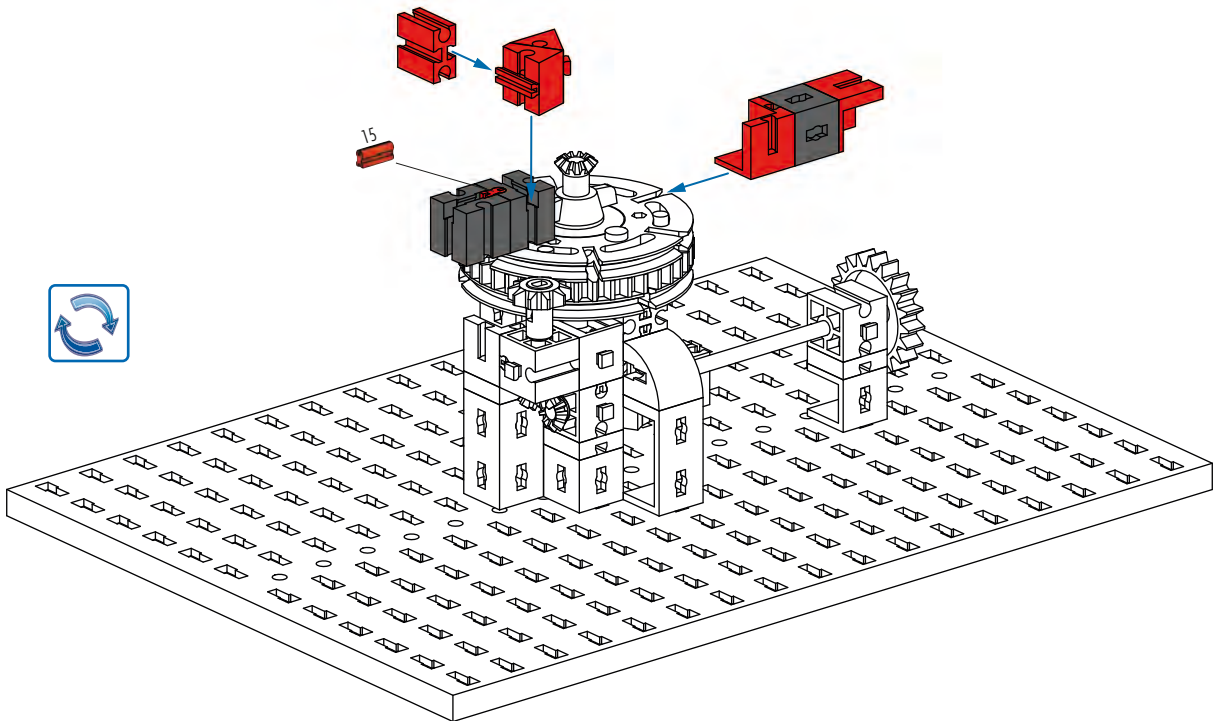

- 12**
- 1x (Red 1x2 Technic Brick with Hole)
 - 1x (Red 1x2 Technic Brick with Hole)
 - 2x (Red 1x2 Technic Brick with Hole)
 - 1x (Red 1x2 Technic Brick with Hole)
 - 2x (Grey 1x2 Technic Brick with Hole)
 - 2x (Grey 1x2 Technic Brick with Hole)
 - 1x (Red 1x2 Technic Brick with Hole)

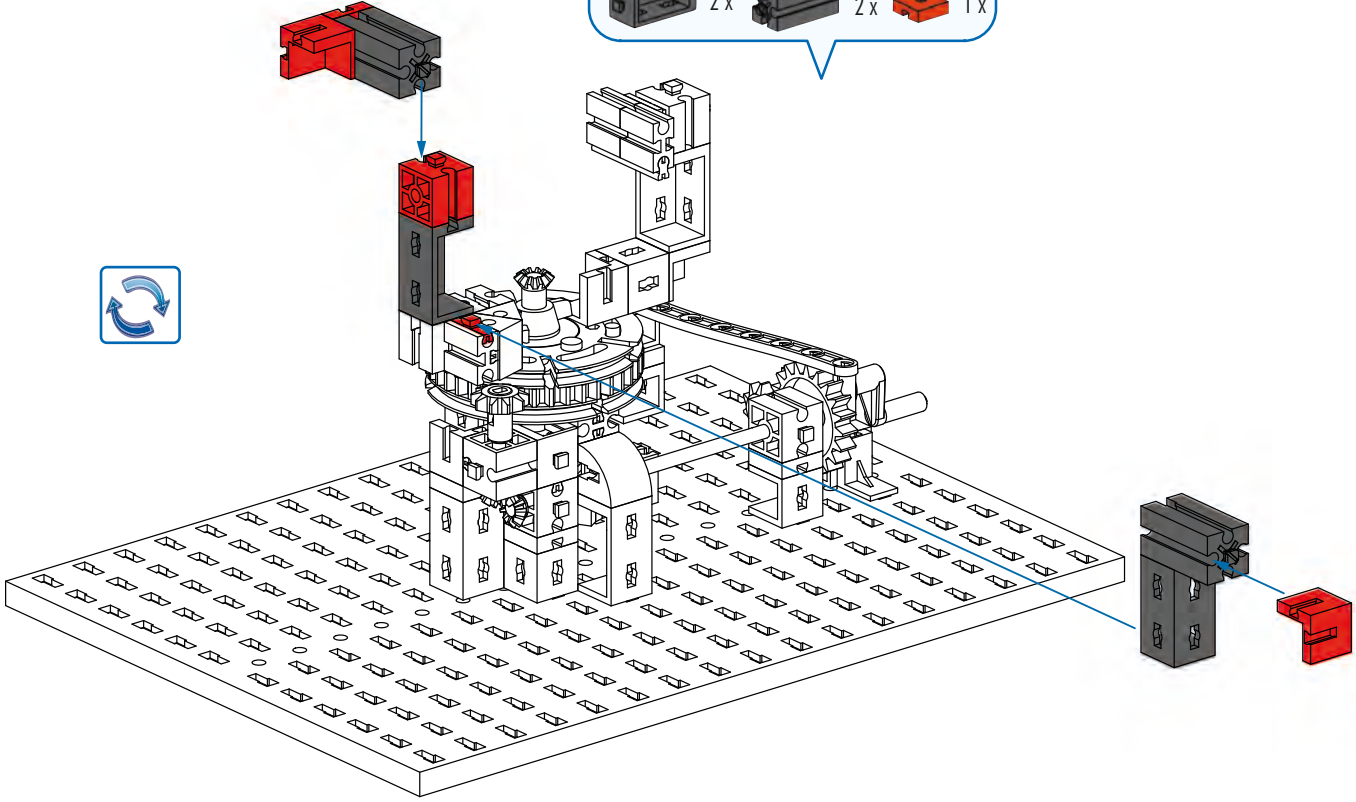

- 13**
- 1x (Red 24-tooth Technic Gear)
 - 4x (Red 1x2 Technic Brick with Hole)
 - 1x (Grey Technic Pin)
 - 2x (Red 1x2 Technic Brick with Hole)
 - 1x (Red 30-length Technic Pin)

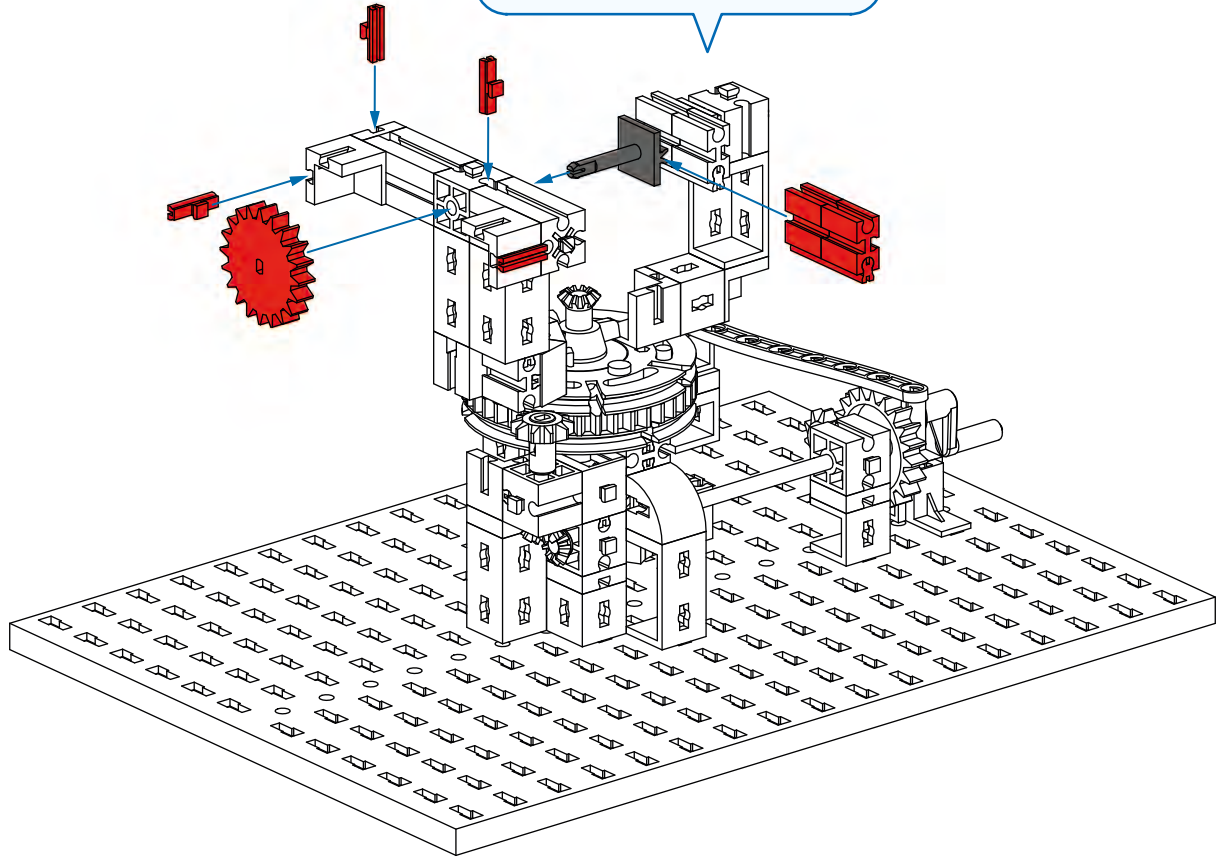

- 14**
- 1 x [Red 1x3 Technic Brick]
 - 2 x [Red L-shaped Technic Connector]
 - 2 x [Red Technic Pin with Friction Ridge]
 - 2 x [Red Technic Pin with Friction Ridge]
 - 2 x [Red 1x2 Technic Brick]
 - 2 x [Grey Technic Axle, length 60]

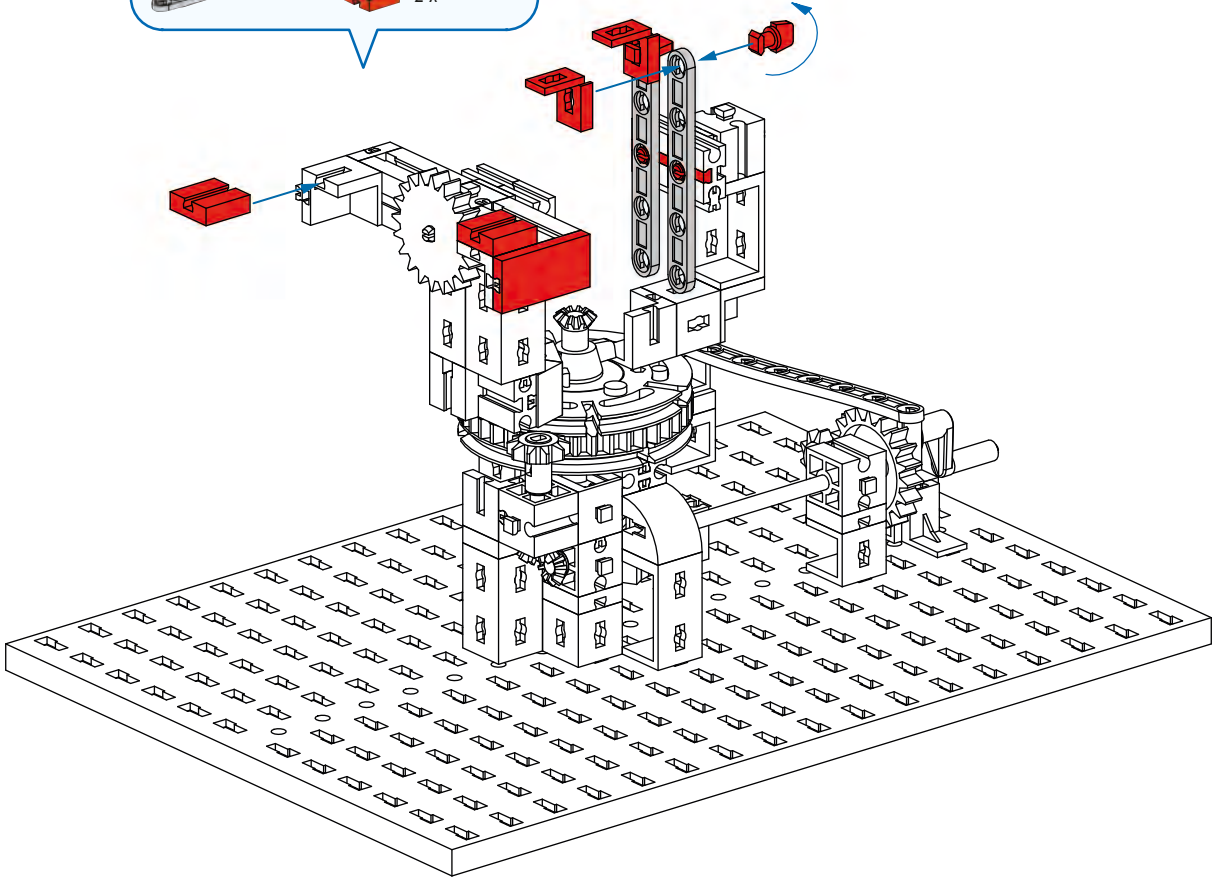

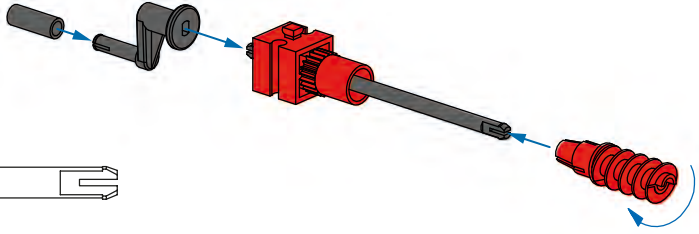

- 15**
- 1 x [Grey Technic Pin]
 - 1 x [Red 1x2 Technic Brick]
 - 1 x [Red Technic Pin with Friction Ridge]
 - 1 x [Black L-shaped Technic Connector]
 - 1 x [Grey Technic Axle, length 90]
 - 1 x [Red Technic Pin with Friction Ridge]



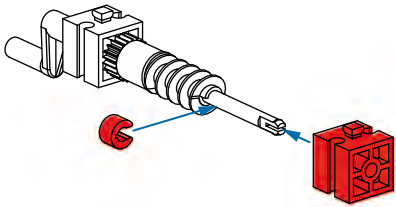



90 mm

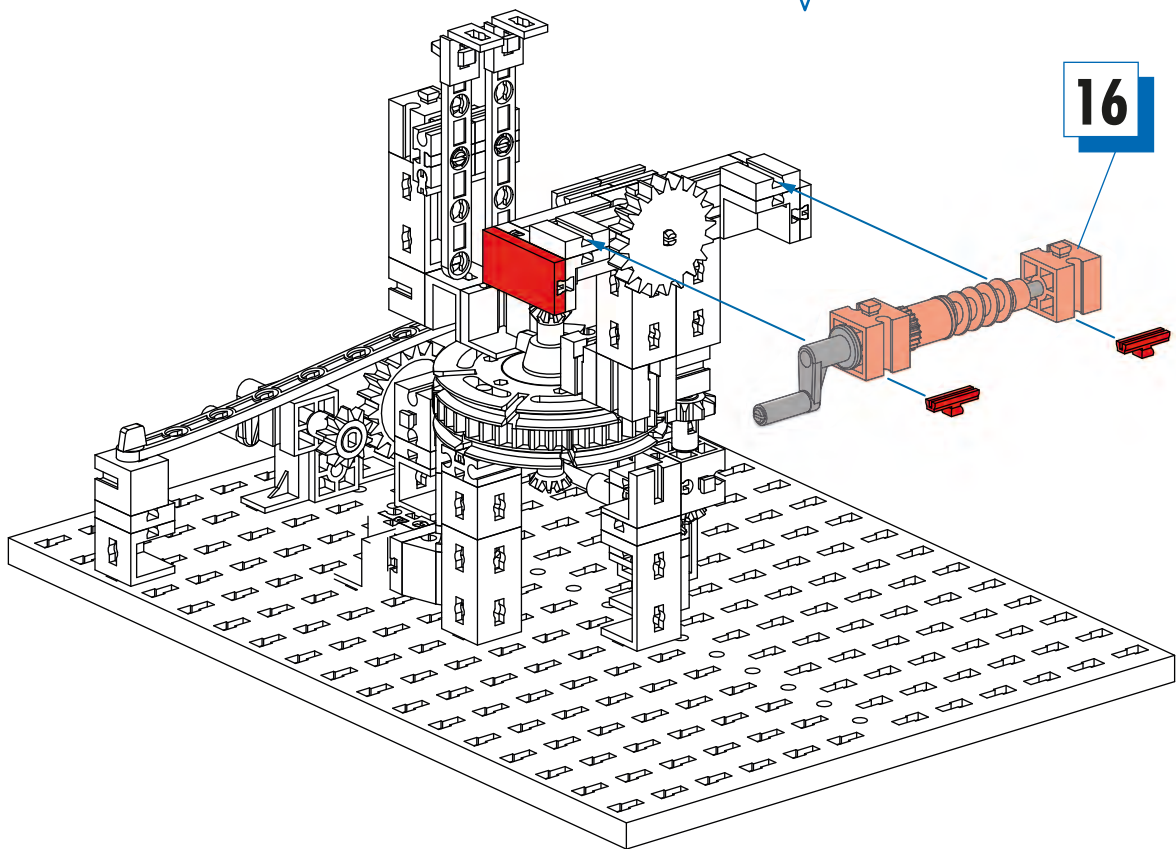

- 16**
- 1 x [Red 1x2 Technic Brick]
 - 1 x [Red Technic Pin with Friction Ridge]

17  1x  2x



18  2x  2x
 2x  2x

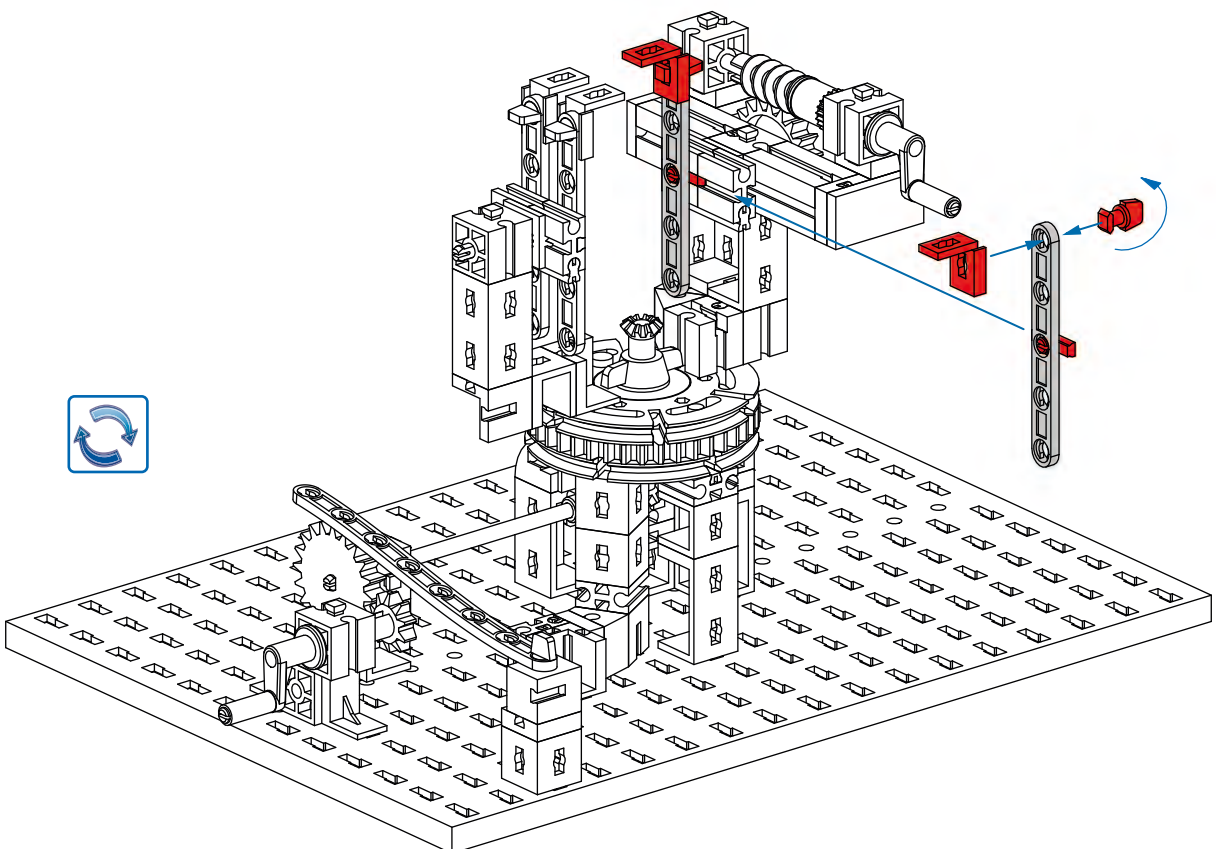

19

- 60 2 x
- 105 2 x
- A 8 x

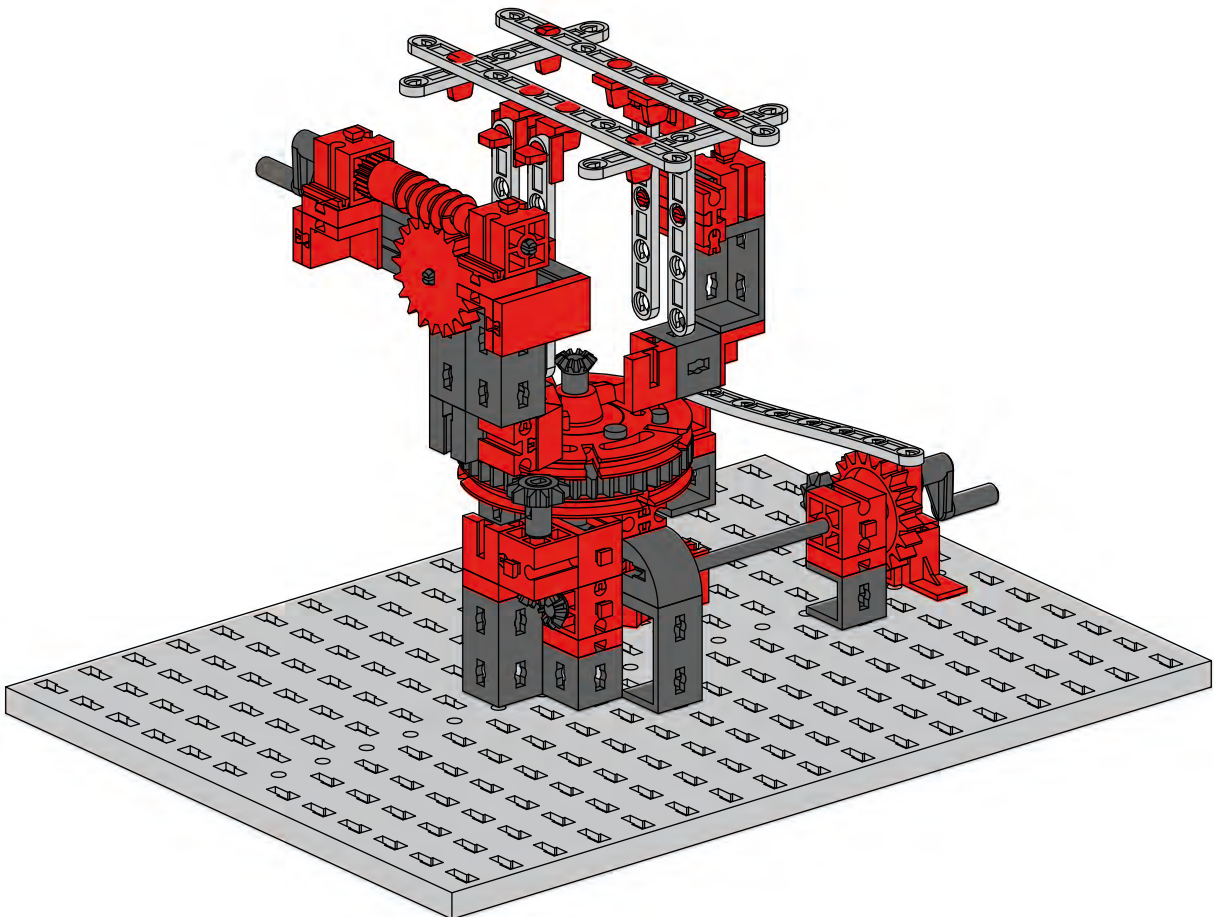
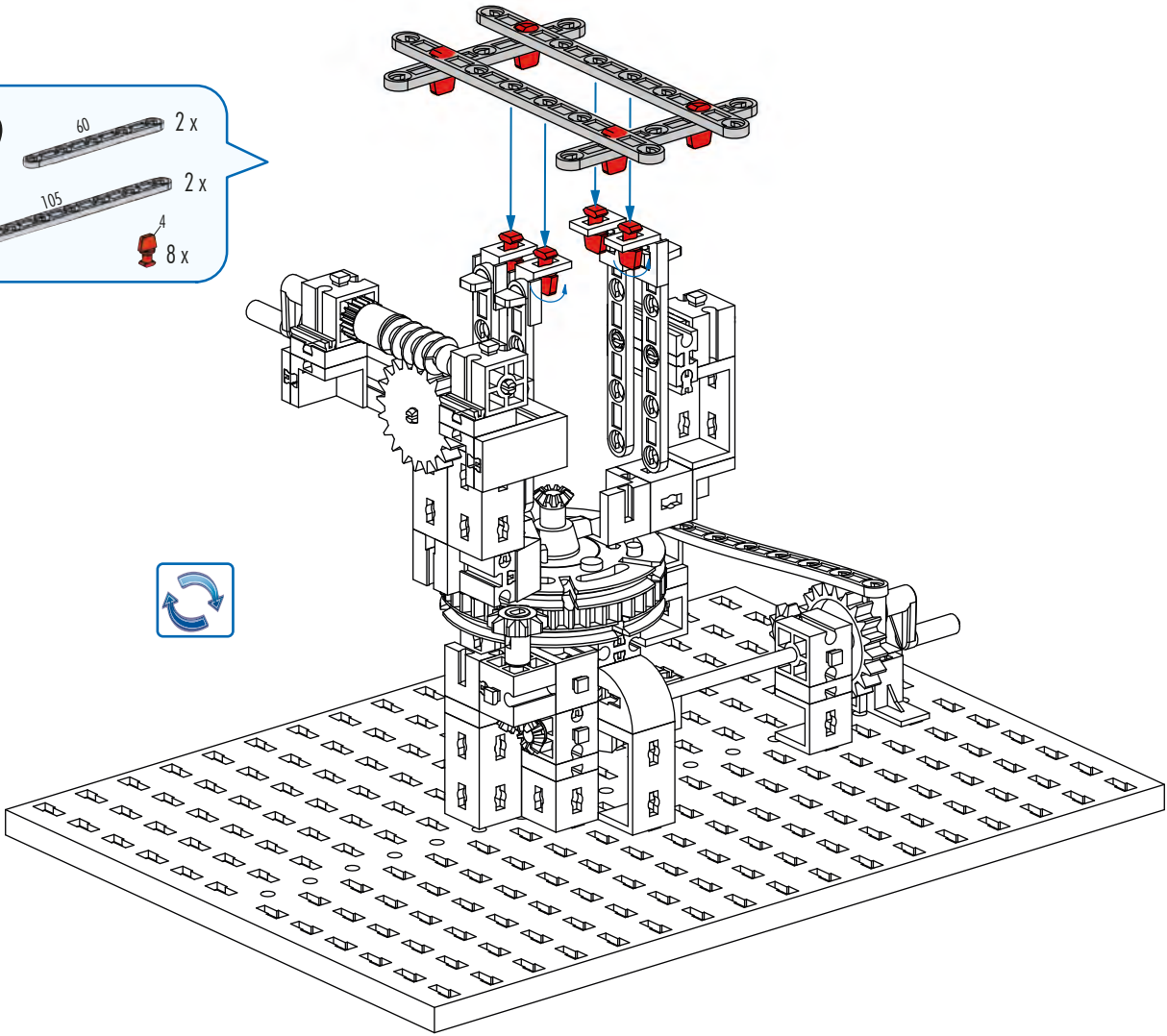

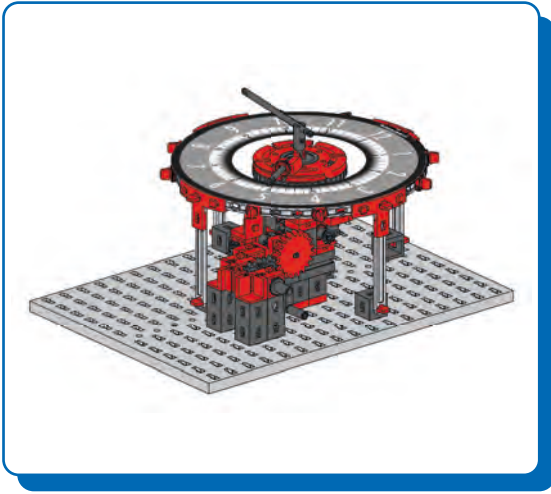

Uhrwerk
Clockworks
Mouvement

Clockwork
Reloj
Clockwork

Orologio
Часовой механизм
发条

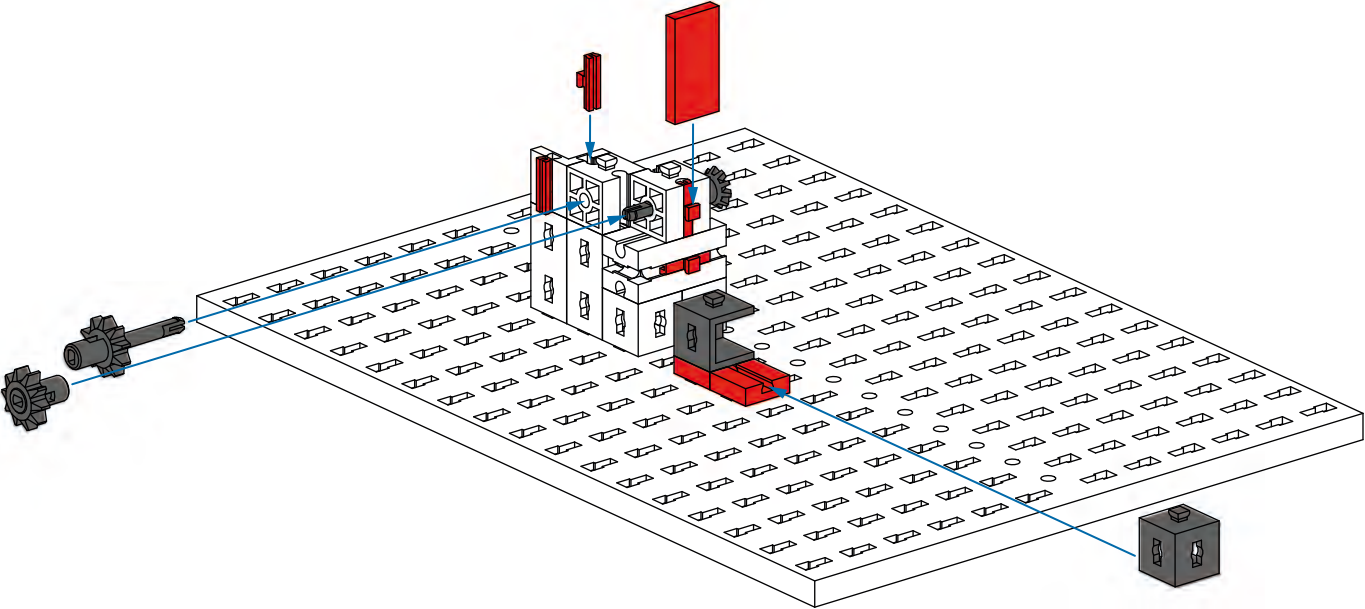
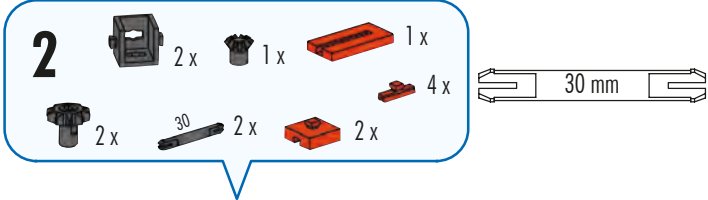
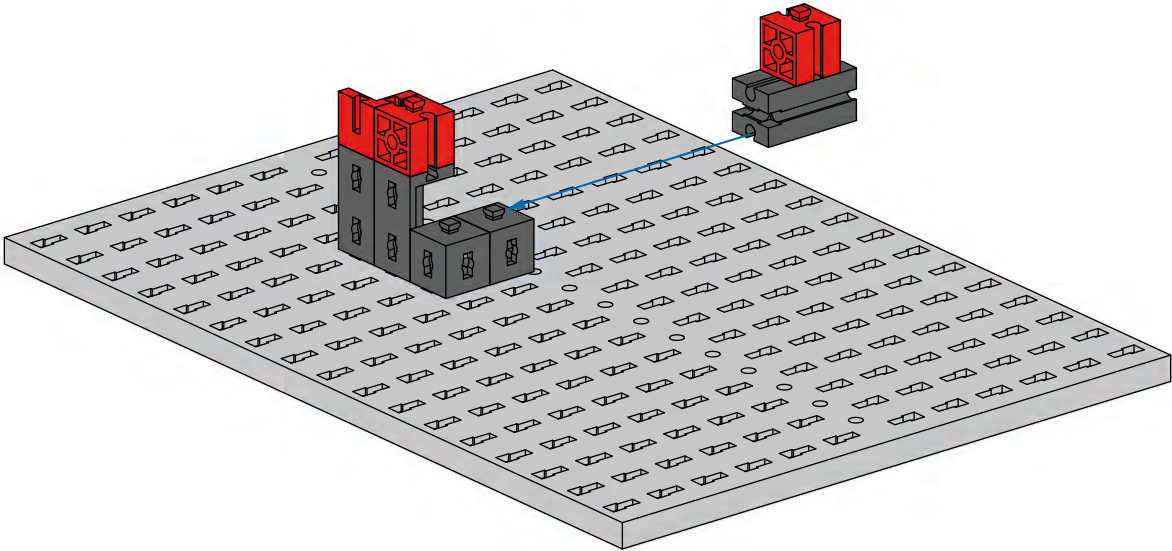
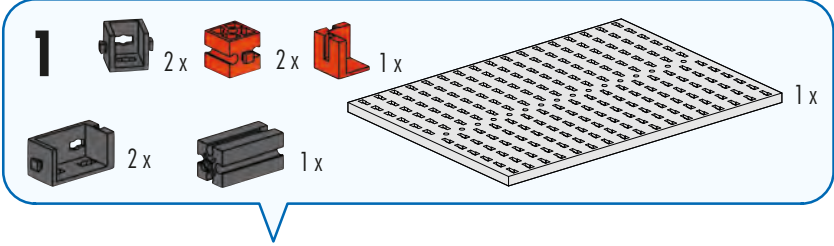

3

- 1x Red 2-way Technic Connector
- 1x Red L-shaped Technic Connector
- 1x Red 1x3 Technic Beam
- 2x Black 1x3 Technic Beam
- 1x Black 30mm Technic Pin
- 1x Black Technic Axle
- 2x Red 1x2 Technic Beam
- 1x Black Technic Pin

30 mm

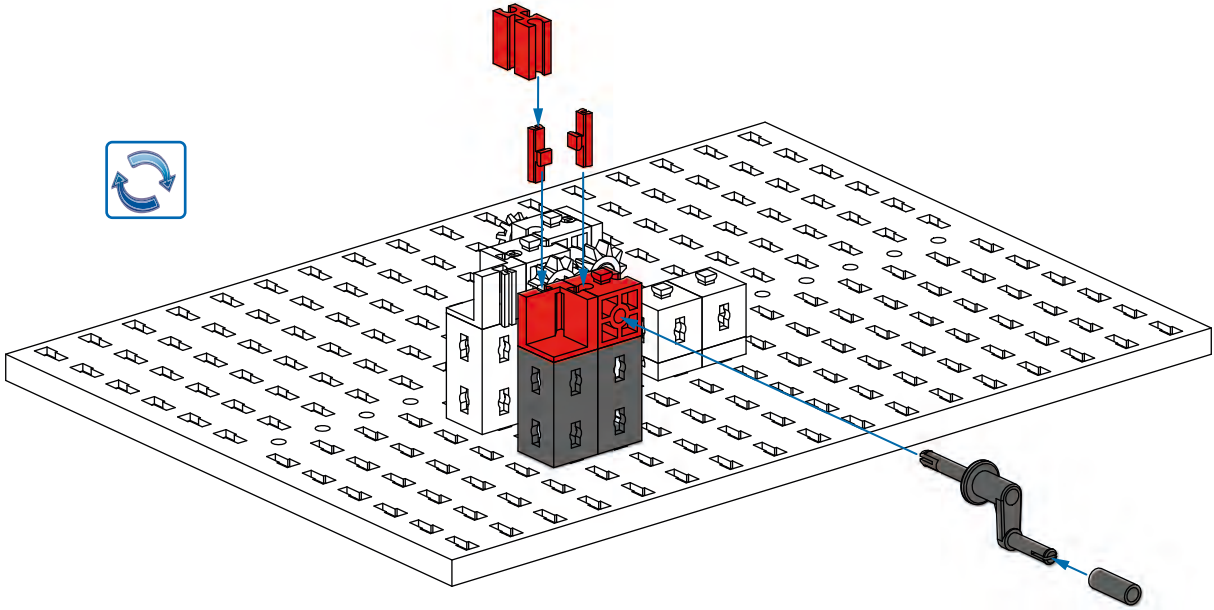

4

- 1x Red 2-way Technic Connector
- 1x Red L-shaped Technic Connector
- 3x Red 1x2 Technic Beam
- 1x Black 1x3 Technic Beam
- 1x Black 1x3 Technic Beam
- 1x Black 1x3 Technic Beam

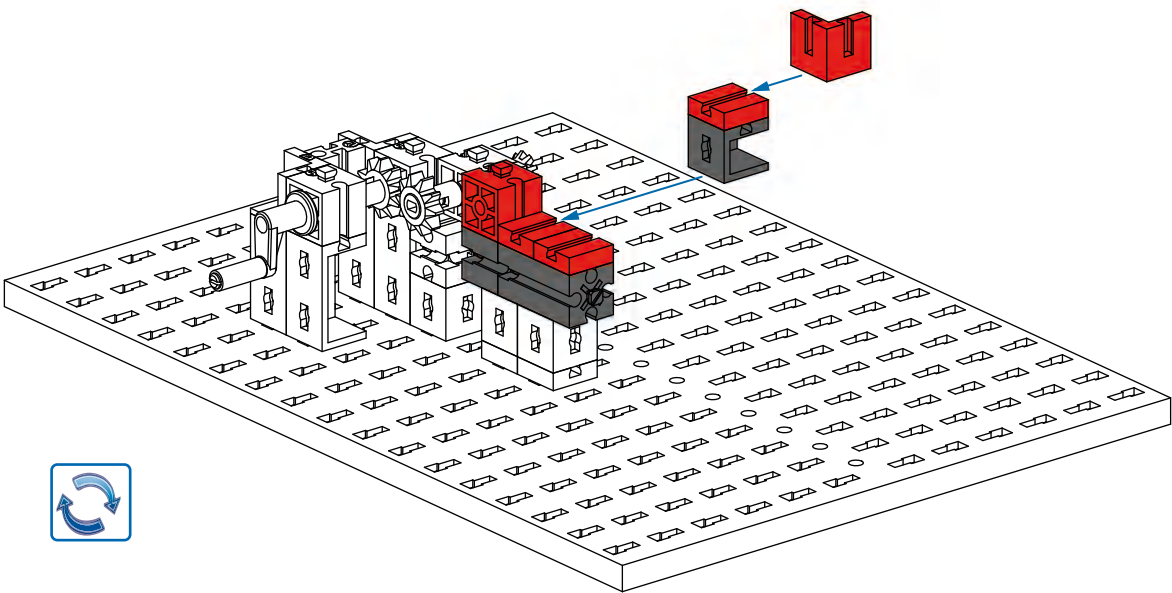

5

- 1x [Black Pin with Friction Ridge]
- 1x [Black Pin with Friction Ridge]
- 1x [Red Technic Bracket]
- 1x [Black Pin with Friction Ridge]
- 1x [Red Pin]
- 1x [Black Pin with Friction Ridge]
- 1x [Black Pin with Friction Ridge]
- 1x [Red Gear]

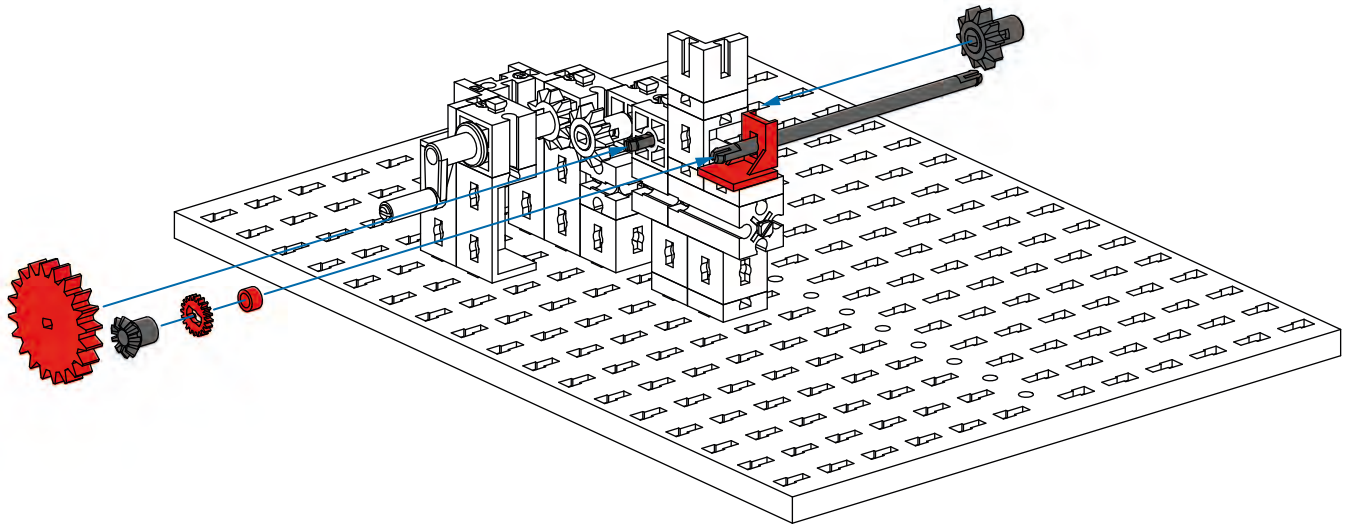
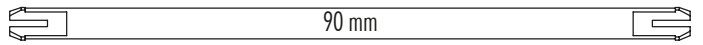
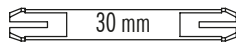

6

- 1x [Red Pin with Friction Ridge]
- 1x [Red Pin with Friction Ridge]
- 2x [Black Technic Bracket]
- 1x [Black Gear]

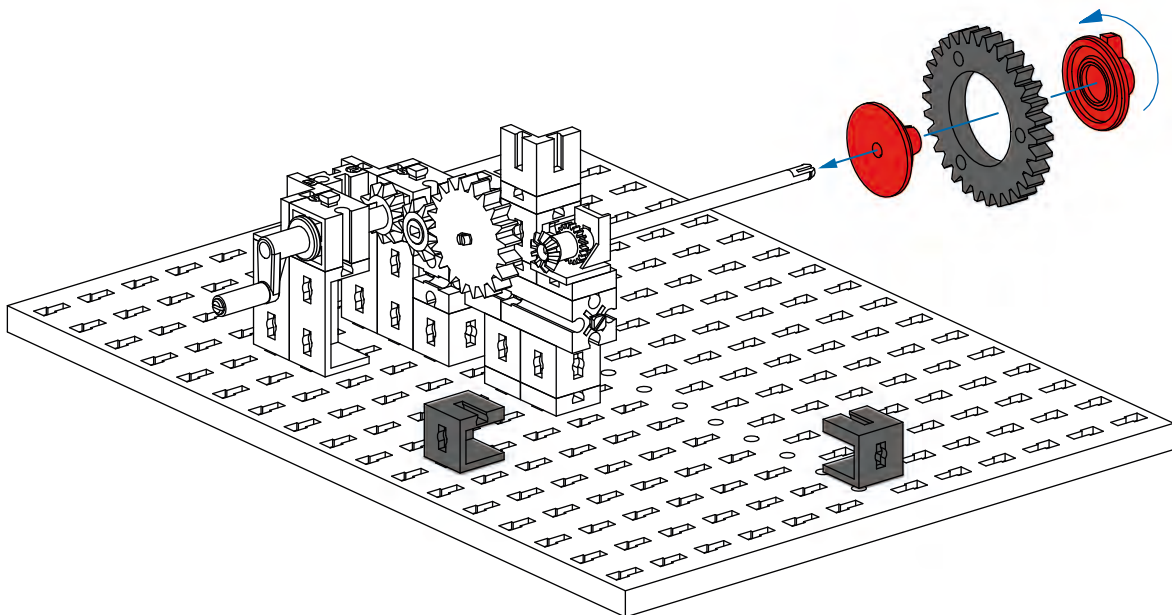

7

- 2x Red 1x2x2 Technic Bricks
- 1x Grey Technic Pin (30)
- 1x Red 1x2 Technic Brick
- 1x Red 1x2 Technic Brick with Hole
- 1x Red 1x2 Technic Brick with Hole
- 1x Red 1x2 Technic Brick with Hole
- 1x Red 1x2 Technic Brick with Hole

30 mm

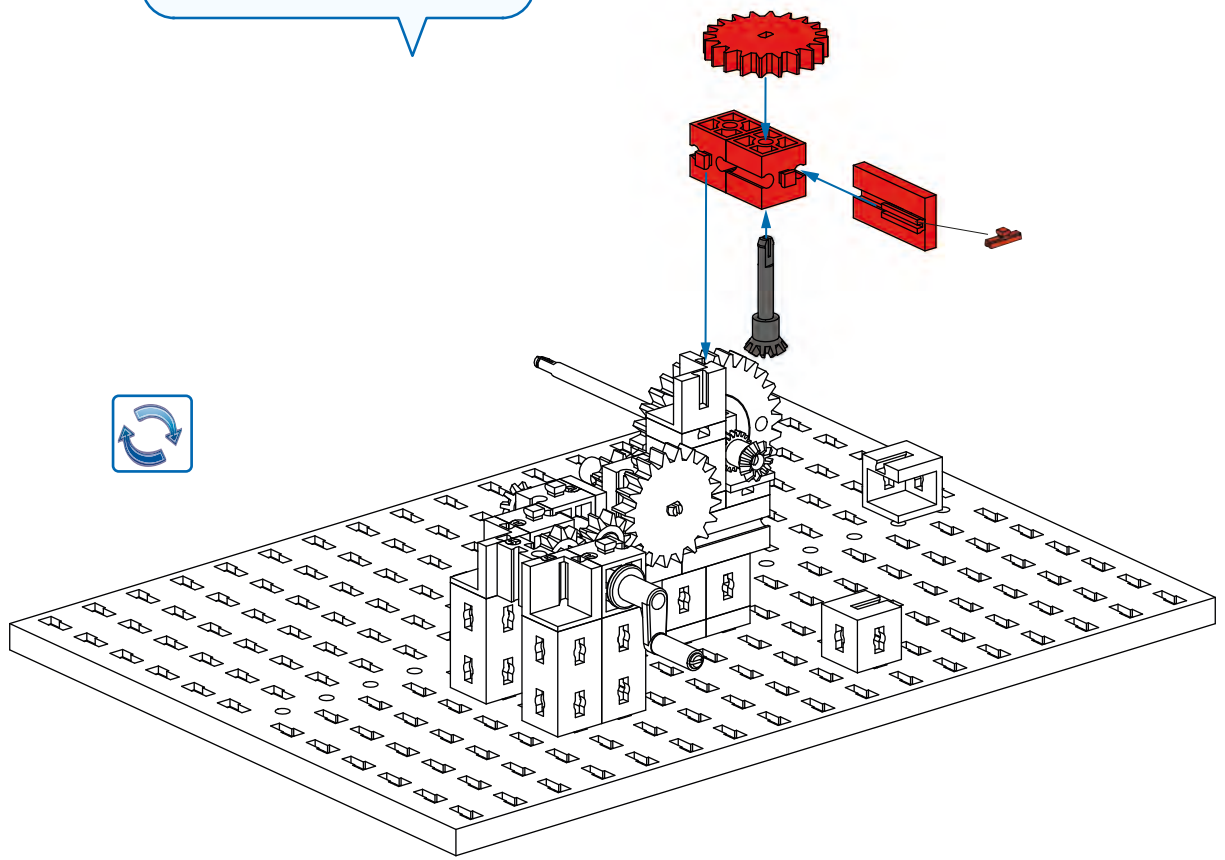





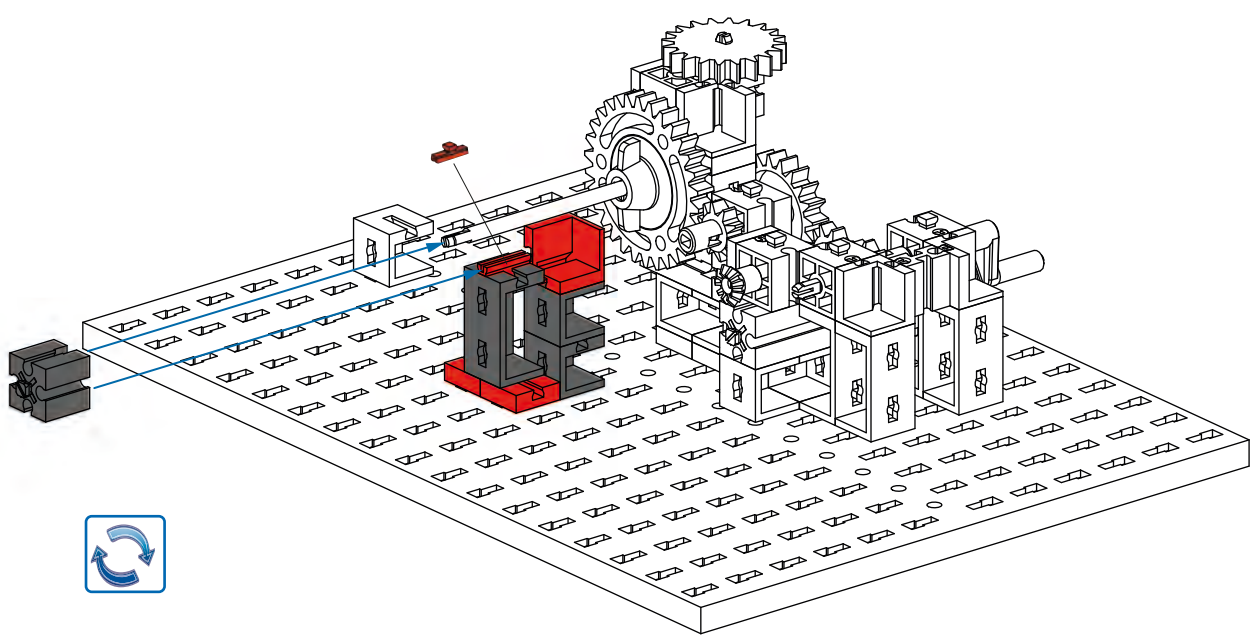

8

- 1x Grey Technic Pin
- 1x Red 1x2 Technic Brick with Hole
- 2x Red 1x2 Technic Bricks
- 1x Red 1x2 Technic Brick with Hole
- 1x Grey Technic Pin
- 1x Grey Technic Pin
- 1x Grey Technic Pin



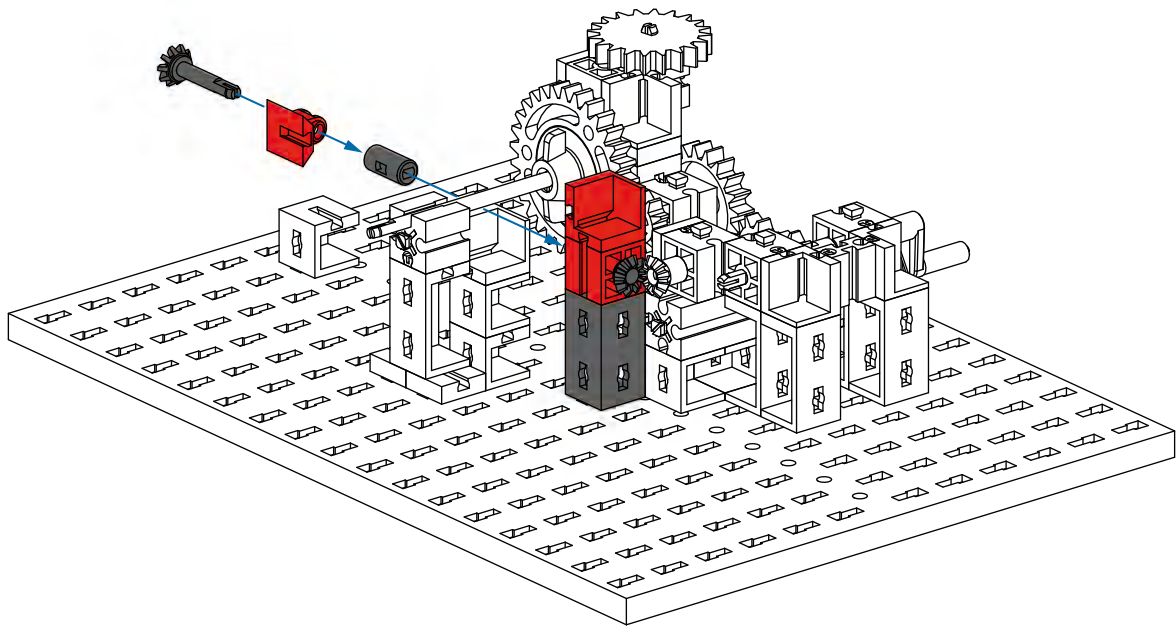

9

- 2x 
- 1x 
- 1x 
- 1x 
- 1x 
- 1x 

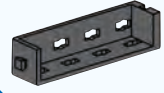

10

- 3x 
- 1x 
- 3x 

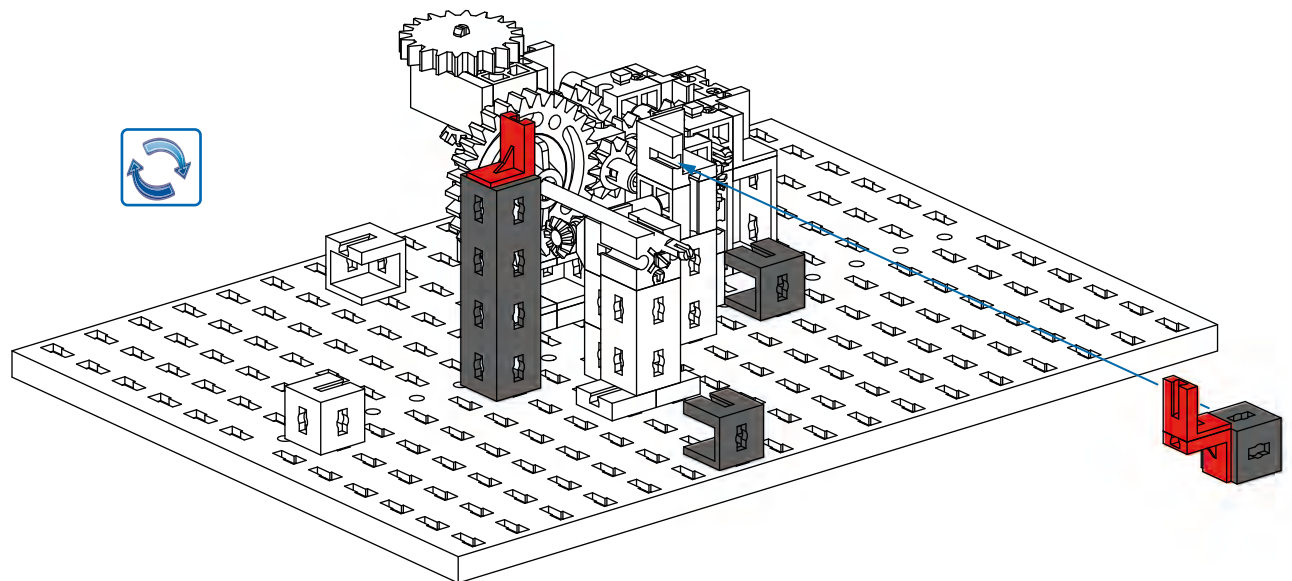

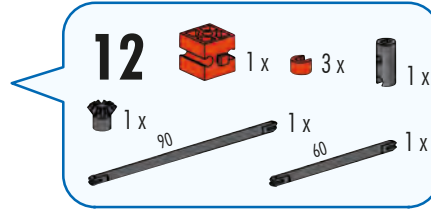
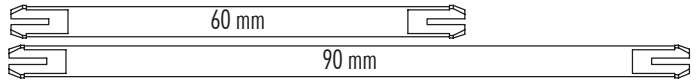
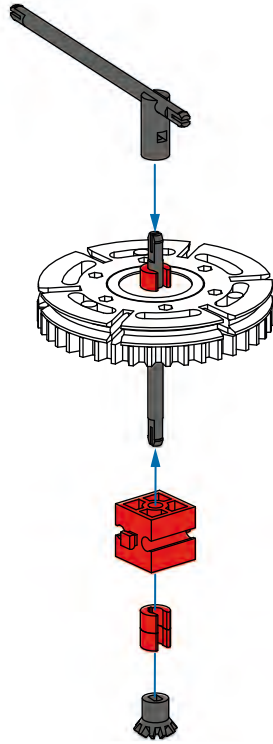
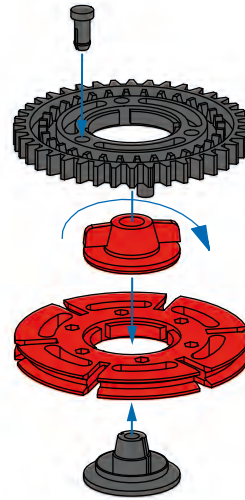
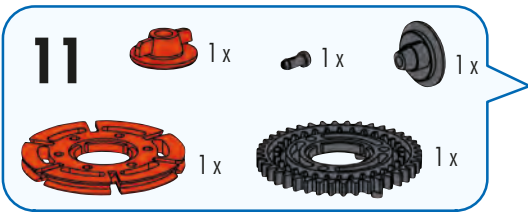



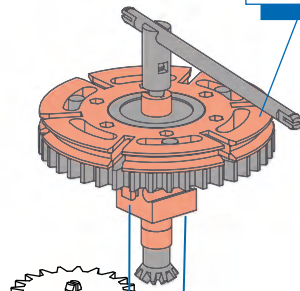

12

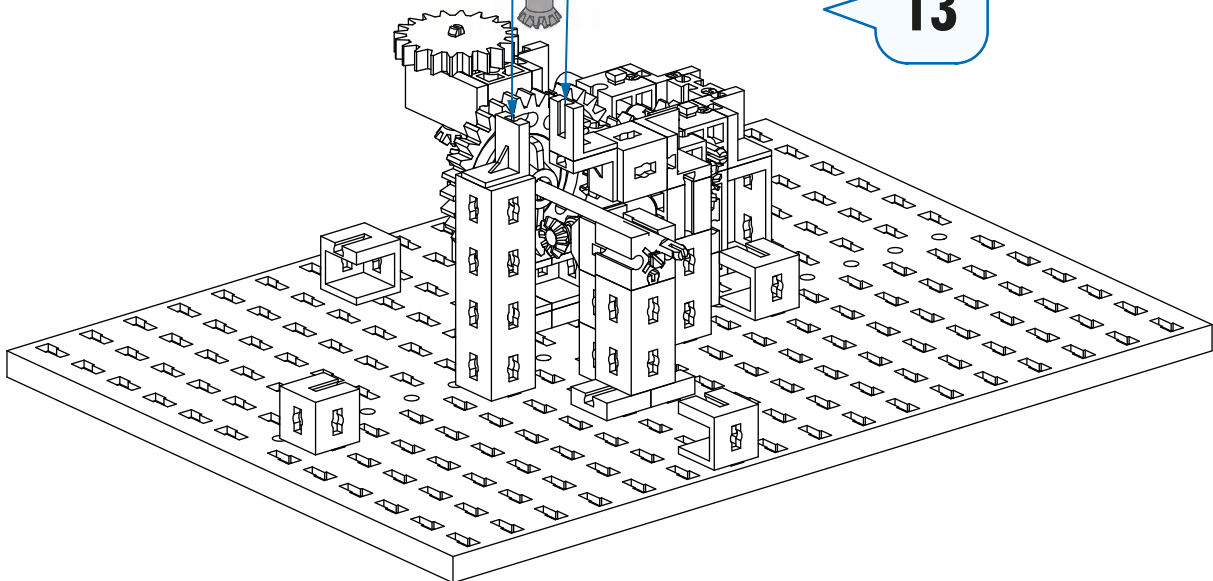

13



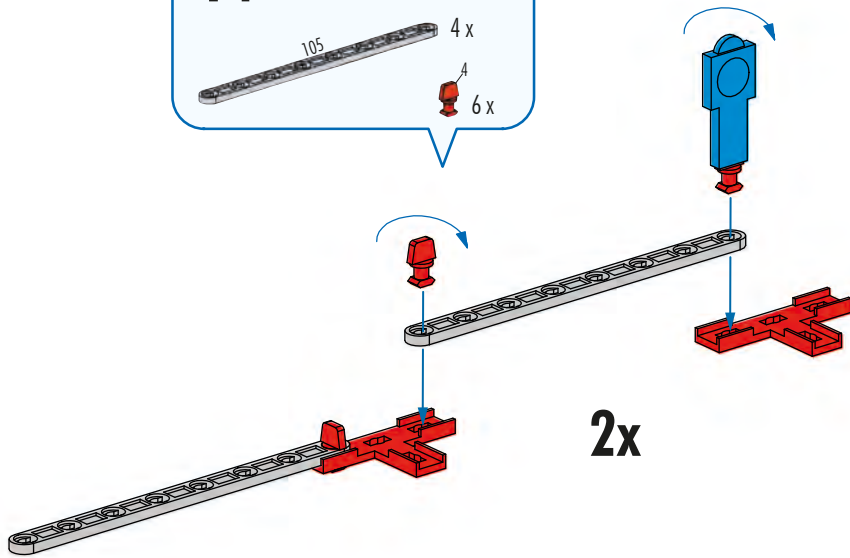

14  4 x
 4 x
 6 x

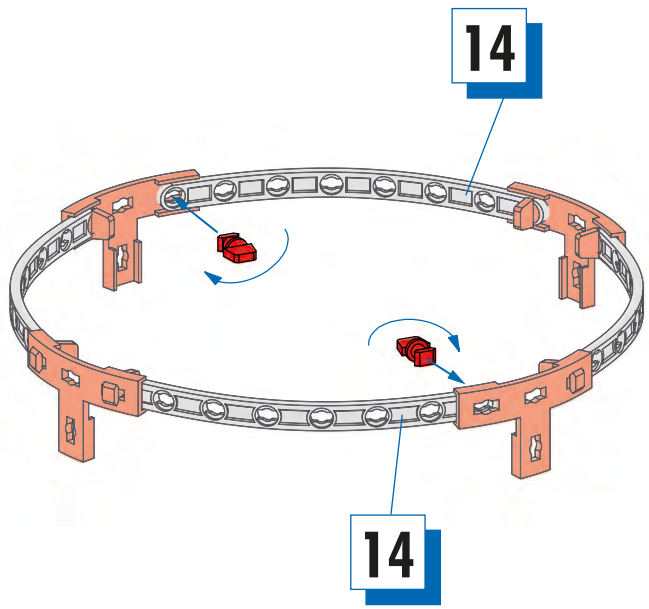

15  2 x

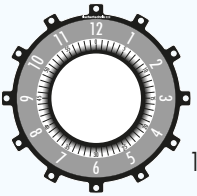

16  4 x
 4 x
 1 x

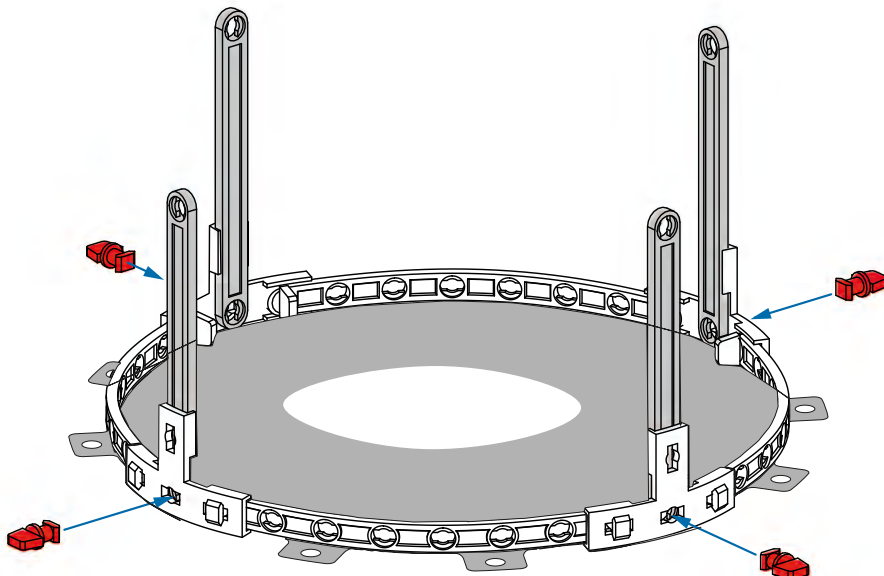

17

- 15° 1 x
- 9 x
- 45 1 x
- 12 x

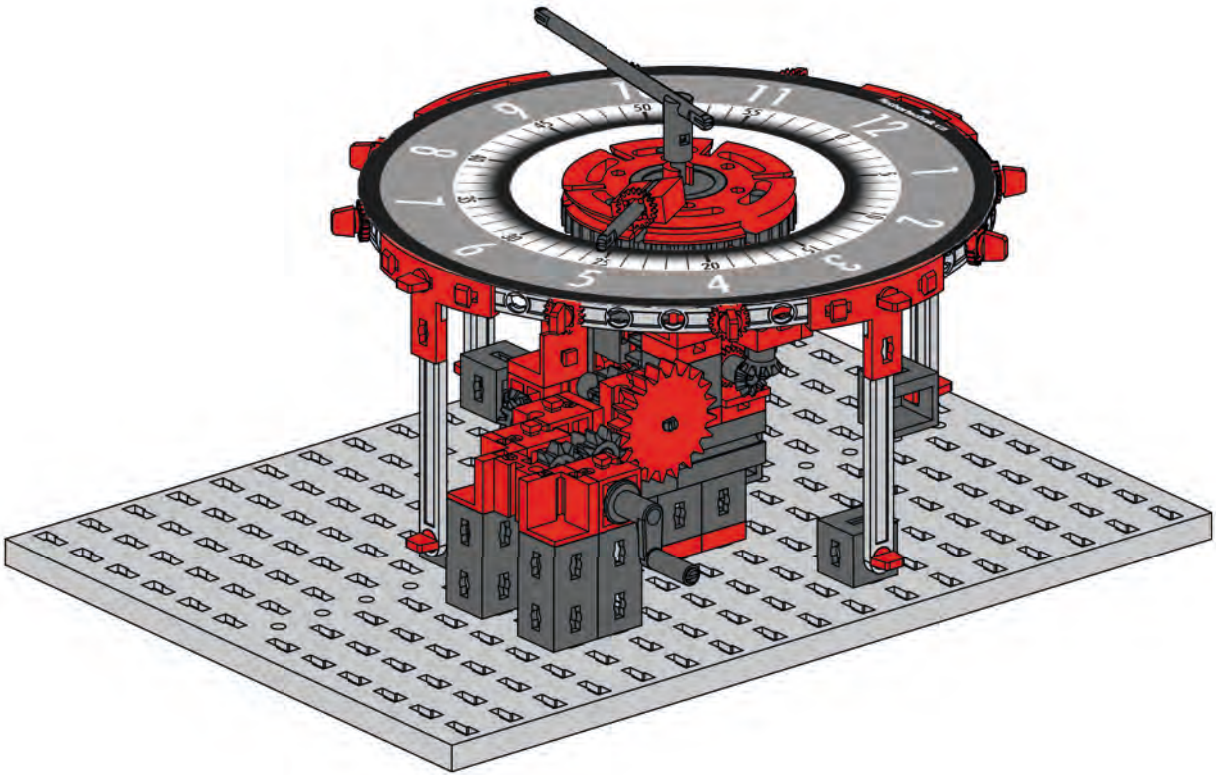
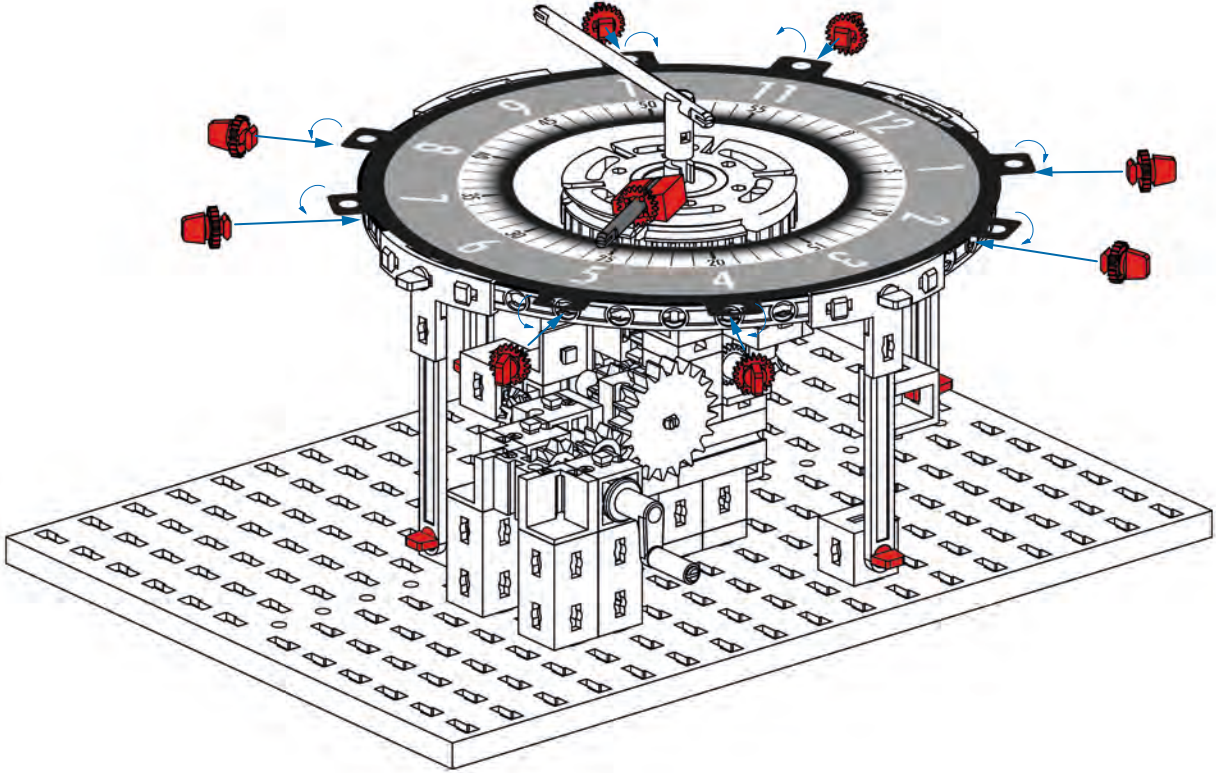
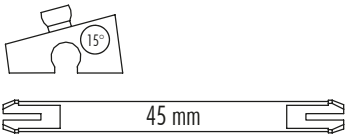



1

- 2x
- 5x
- 1x

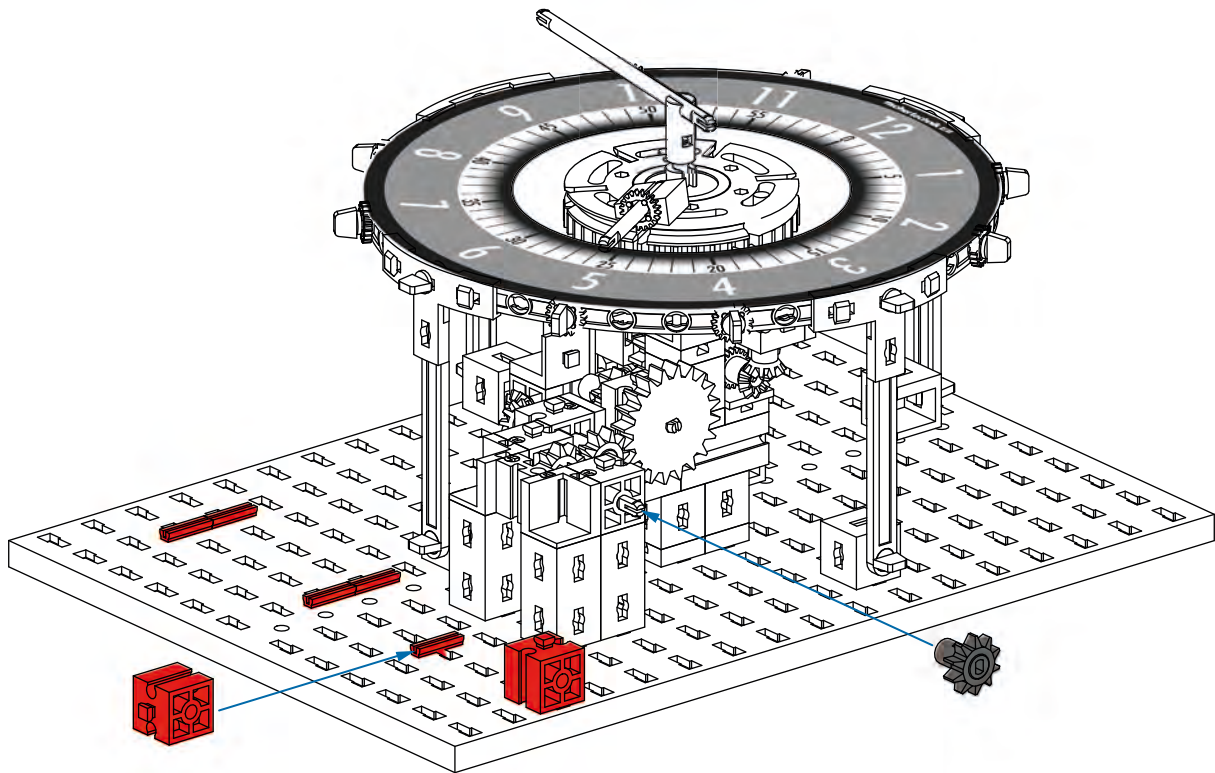

2

- 1x
- 1x
- 1x
- 1x
- 2x
- 1x
- 1x
- 1x

