

# Loads FIS EM Plus with FIS A under tensile stress

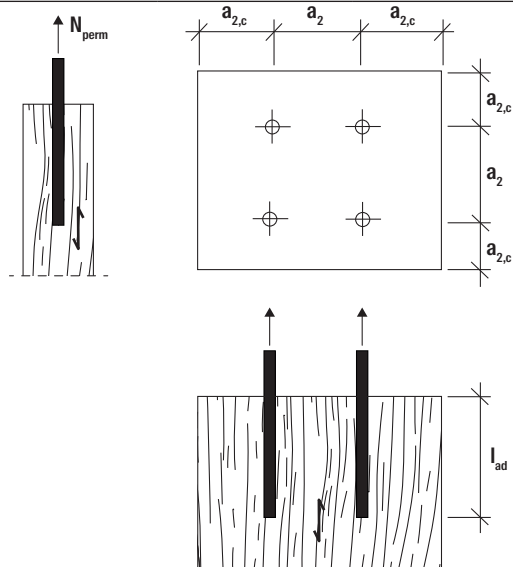

## Injection system FIS EM Plus with anchor rod FIS A

Permissible tensile loads of a single anchor rod in glued laminated timber components  $\geq$  GL24h

Anchor rods glued in parallel to the grain direction of the timber component

For the design, the entire approval Z-9.1-914 and DIN EN 1995-1-1:2010-12 / NA must be observed.

Type	Material/surface [-]	Gluing length in timber component $l_{ad}$ [mm]	Permissible tensile load $N_{perm}$ [kN]	Minimum spacing $a_2$ [mm]	Minimum edge distance $a_{2,c}$ [mm]	Minimum component dimensions $b = d$ [mm]
FIS A M 6	5.8	100	3.7	30	15	30
	5.8	240	4.8	30	15	30
	8.8	100	3.7	30	15	30
	8.8	240	7.4	30	15	30
	R-70	100	3.7	30	15	30
	R-70	240	5.2	30	15	30
FIS A M 8	5.8	100	5.0	40	20	40
	5.8	320	8.8	40	20	40
	8.8	100	5.0	40	20	40
	8.8	320	13.4	40	20	40
	R-70	100	5.0	40	20	40
	R-70	320	9.4	40	20	40
FIS A M 10	5.8	100	6.2	50	25	50
	5.8	400	13.9	50	25	50
	8.8	100	6.2	50	25	50
	8.8	400	20.2	50	25	50
	R-70	100	6.2	50	25	50
	R-70	400	14.9	50	25	50
FIS A M 12	5.8	120	8.9	60	30	60
	5.8	480	20.2	60	30	60
	8.8	120	8.9	60	30	60
	8.8	480	25.5	60	30	60
	R-70	120	8.9	60	30	60
	R-70	480	21.7	60	30	60

Type	Material/surface [-]	Gluing length in timber component $l_{ad}$ [mm]	Permissible tensile load $N_{perm}$ [kN]	Minimum spacing $a_2$ [mm]	Minimum edge distance $a_{z,c}$ [mm]	Minimum component dimensions $b = d$ [mm]
FIS A M 16	5.8	160	15.9	80	40	80
	5.8	640	37.7	80	40	80
	8.8	160	15.9	80	40	80
	8.8	640	40.4	80	40	80
	R-70	160	15.9	80	40	80
	R-70	640	40.4	80	40	80
FIS A M 20	5.8	200	24.9	100	50	100
	5.8	800	57.2	100	50	100
	8.8	200	24.9	100	50	100
	8.8	800	57.2	100	50	100
	R-70	200	24.9	100	50	100
	R-70	800	57.2	100	50	100
FIS A M 24	5.8	240	35.8	120	60	120
	5.8	960	73.7	120	60	120
	8.8	240	35.8	120	60	120
	8.8	960	73.7	120	60	120
	R-70	240	35.8	120	60	120
	R-70	960	73.7	120	60	120
FIS A M 30	5.8	300	52.4	150	75	150
	5.8	1000	93.2	150	75	150
	8.8	300	52.4	150	75	150
	8.8	1000	93.2	150	75	150
	R-70	300	52.4	150	75	150
	R-70	1000	93.2	150	75	150

Notes:

Drill diameter in the wood 4 mm larger than the outer diameter of the steel rods.

Steel failure in the stress cross-section against the yield strength, composite failure in the lateral surface and tensile failure of the net timber cross-section are taken into account.

Partial safety factors  $\gamma_{M,H} = 1.3$ ;  $\gamma_{M,S} = 1.25$ ;  $\gamma_{F,global} = 1.4$  and  $k_{mod} = 0.9$  from KLED short and NKL 1+2 taken into account.

Values valid for glued laminated timber  $\geq$  GL24h. Higher load-bearing capacities may be possible for higher strength classes. For

groups of steel bars, as well as for combined loading from tensile and shear loads, as well as for bending stress, see Z-9.1-914 and DIN EN 1995-1-1 / NA.

For groups of steel bars glued in parallel to the grain of the timber components, which are subjected to tensile stress in the grain direction, a verification of the connection for block shear failure according to EOTA Technical Report TR 070, Section 4.1.7., is required.

All mechanical values given must be considered in relation to the assumptions made and are examples of dimensioning.

This is a planning aid. Projects must be dimensioned exclusively by structural engineers!

All values are subject to typesetting and printing errors.

# Loads FIS EM Plus with FIS A under tensile stress

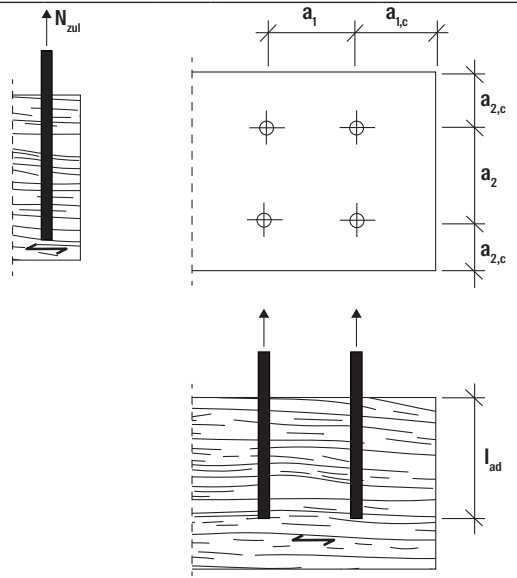

## Injection system FIS EM Plus with anchor rod FIS A

Permissible tensile loads of a single anchor rod in glued laminated timber components  $\geq$  GL24h  
Anchor rods glued in perpendicular to the grain direction of the timber component

For the design, the entire approval Z-9.1-914 and DIN EN 1995-1-1:2010-12 / NA must be observed.

Type	Material/surface [-]	Gluing length in timber component $l_{ad}$ [mm]	Permissible tensile load $N_{perm}$ [kN]	Minimum spacing $a_1 = a_2$ [mm]	Minimum edge distance $a_{1,c} = a_{2,c}$ [mm]	Minimum component width $b$ [mm]	Minimum component height $h$ [mm]
FIS A M 6	5.8	100	3.7	24	15	30	120
	5.8	240	4.8	24	15	30	260
	8.8	100	3.7	24	15	30	120
	8.8	240	7.4	24	15	30	260
	R-70	100	3.7	24	15	30	120
	R-70	240	5.2	24	15	30	260
FIS A M 8	5.8	100	5.0	32	20	40	120
	5.8	320	8.8	32	20	40	340
	8.8	100	5.0	32	20	40	120
	8.8	320	13.4	32	20	40	340
	R-70	100	5.0	32	20	40	120
	R-70	320	9.4	32	20	40	340
FIS A M 10	5.8	100	6.2	40	25	50	120
	5.8	400	13.9	40	25	50	420
	8.8	100	6.2	40	25	50	120
	8.8	400	20.2	40	25	50	420
	R-70	100	6.2	40	25	50	120
	R-70	400	14.9	40	25	50	420
FIS A M 12	5.8	120	8.9	48	30	60	140
	5.8	480	20.2	48	30	60	500
	8.8	120	8.9	48	30	60	140
	8.8	480	25.5	48	30	60	500
	R-70	120	8.9	48	30	60	140
	R-70	480	21.7	48	30	60	500
FIS A M 16	5.8	160	15.9	64	40	80	180
	5.8	640	37.7	64	40	80	660
	8.8	160	15.9	64	40	80	180
	8.8	640	40.4	64	40	80	660
	R-70	160	15.9	64	40	80	180
	R-70	640	40.4	64	40	80	660

Type	Material/surface [-]	Gluing length in timber component $l_{ad}$ [mm]	Permissible tensile load $N_{perm}$ [kN]	Minimum spacing $a_1 = a_2$ [mm]	Minimum edge distance $a_{1,c} = a_{2,c}$ [mm]	Minimum component width $b$ [mm]	Minimum component height $h$ [mm]
FIS A M 20	5.8	200	24.9	80	50	100	220
	5.8	800	57.2	80	50	100	820
	8.8	200	24.9	80	50	100	220
	8.8	800	57.2	80	50	100	820
	R-70	200	24.9	80	50	100	220
	R-70	800	57.2	80	50	100	820
FIS A M 24	5.8	240	35.8	96	60	120	260
	5.8	960	73.7	96	60	120	980
	8.8	240	35.8	96	60	120	260
	8.8	960	73.7	96	60	120	980
	R-70	240	35.8	96	60	120	260
	R-70	960	73.7	96	60	120	980
FIS A M 30	5.8	300	52.4	120	75	150	320
	5.8	1000	93.2	120	75	150	1020
	8.8	300	52.4	120	75	150	320
	8.8	1000	93.2	120	75	150	1020
	R-70	300	52.4	120	75	150	320
	R-70	1000	93.2	120	75	150	1020

Notes:

Drill diameter in the wood 4 mm larger than the outer diameter of the steel rods.

Steel failure in the stress cross-section against the yield point and composite failure in the lateral surface are taken into account.

Any failure of the timber cross-section such as transverse tensile failure and block shear failure must be checked separately!

Partial safety factors  $\gamma_{M,H} = 1.3$ ;  $\gamma_{M,S} = 1.25$ ;  $\gamma_{F,global} = 1.4$  and  $k_{mod} = 0.9$  from KLED short and NKL 1+2 taken into account.

Values valid for glued laminated timber  $\geq$  GL24h. Higher load-bearing capacities may be possible for higher strength classes.

For groups of steel bars, as well as for combined loading from tensile and shear loads, as well as for bending stress, see Z-9.1-914 and DIN EN 1995-1-1 / NA.

All mechanical values given must be considered in relation to the assumptions made and are examples of dimensioning.

This is a planning aid. Projects must be dimensioned exclusively by structural engineers!

All values are subject to typesetting and printing errors.

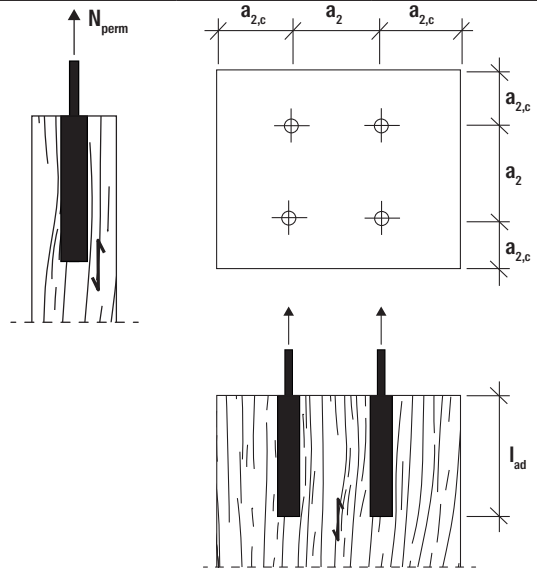

Injection system FIS EM Plus with internal threaded anchor FIS IG

Permissible tensile loads of a single internally threaded anchor in glued laminated timber components  $\geq$  GL24h

Internally threaded anchor glued in parallel to the grain direction of the timber component

For the design, the entire approval Z-9.1-914 and DIN EN 1995-1-1:2010-12 / NA must be observed.

Type	Steel grade of the screw [-]	Gluing length in timber component $l_{ad}$ [mm]	Permissible tensile load $N_{perm}$ [kN]	Minimum spacing $a_2$ [mm]	Minimum edge distance $a_{2,c}$ [mm]	Minimum component dimensions $b = d$ [mm]
FIS IG M 8	5.8	120	8.8	60	30	60
	8.8	120	8.9	60	30	60
	R-70	120	8.9	60	30	60
FIS IG M 10	5.8	160	13.9	80	40	80
	8.8	160	15.9	80	40	80
	R-70	160	14.9	80	40	80
FIS IG M 12	5.8	200	20.2	100	50	100
	8.8	200	24.9	100	50	100
	R-70	200	21.7	100	50	100
FIS IG M 16	5.8	240	35.8	120	60	120
	8.8	240	35.8	120	60	120
	R-70	240	35.8	120	60	120
FIS IG M 20	5.8	300	52.4	150	75	150
	8.8	300	52.4	150	75	150
	R-70	300	52.4	150	75	150

Notes:

Drill diameter in the wood 4 mm larger than the outer diameter of the internal threaded anchor FIS IG.

Steel failure in the stress cross-section of the FIS IG and the bolt against the yield strength, composite failure in the lateral surface and tensile failure of the net timber cross-section are taken into account.

Only use non-corroding FIS IG with non-corroding screws and FIS IG made of gvz. with screws made of gvz..

Minimum screw-in depth of the screws in the FIS IG in accordance with Z-9.1-914.

Partial safety factors  $\gamma_{M,H} = 1.3$ ;  $\gamma_{M,S} = 1.25$ ;  $\gamma_{F,global} = 1.4$  and  $k_{mod} = 0.9$  from KLED short and NK1 1+2 taken into account.

Values valid for glued laminated timber  $\geq$  GL24h. Higher load-bearing capacities may be possible for higher strength classes.

For groups of steel bars, as well as for combined loading from tensile and shear loads, as well as for bending stress, see Z-9.1-914 and DIN EN 1995-1-1 / NA.

For groups of FIS IG glued in parallel to the grain of the timber components, which are subjected to tensile stress in the direction of the grain, the connection must be verified for block shear failure in accordance with EOTA Technical Report TR 070, Section 4.1.7.

All mechanical values given must be considered in relation to the assumptions made and are examples of dimensioning.

This is a planning aid. Projects must be dimensioned exclusively by structural engineers!

All values are subject to typesetting and printing errors.

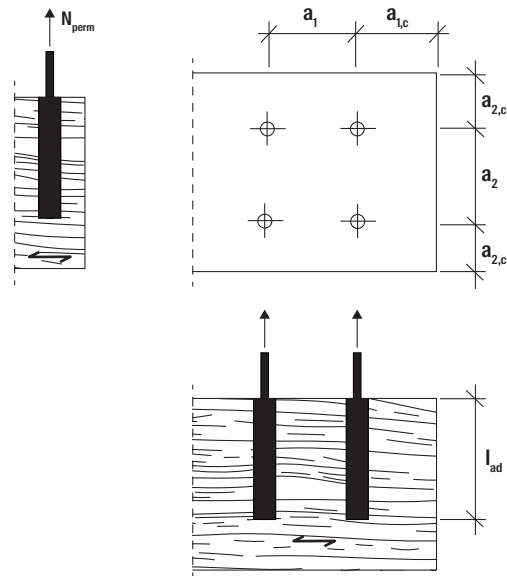

Injection system FIS EM Plus with internally threaded anchors FIS IG

Permissible tensile loads of a single internally threaded anchor in glued laminated timber components  $\geq$  GL24h

Internally threaded anchor glued in perpendicular to the grain direction of the timber component

For the design, the entire approval Z-9.1-914 and DIN EN 1995-1-1:2010-12 / NA must be observed.

Type	Steel grade of the screw [-]	Gluing length in timber component $l_{ad}$ [mm]	Permissible tensile load $N_{perm}$ [kN]	Minimum spacing $a_1 = a_2$ [mm]	Minimum edge distance $a_{1,c} = a_{2,c}$ [mm]	Minimum component width $b$ [mm]	Minimum component height $h$ [mm]
FIS IG M 8	5.8	120	8.8	48	30	60	140
	8.8	120	8.9	48	30	60	140
	R-70	120	8.9	48	30	60	140
FIS IG M 10	5.8	160	13.9	64	40	80	180
	8.8	160	15.9	64	40	80	180
	R-70	160	14.9	64	40	80	180
FIS IG M 12	5.8	200	20.2	80	50	100	220
	8.8	200	24.9	80	50	100	220
	R-70	200	21.7	80	50	100	220
FIS IG M 16	5.8	240	35.8	96	60	120	260
	8.8	240	35.8	96	60	120	260
	R-70	240	35.8	96	60	120	260
FIS IG M 20	5.8	300	52.4	120	75	150	320
	8.8	300	52.4	120	75	150	320
	R-70	300	52.4	120	75	150	320

Notes:

Drill diameter in the wood 4 mm larger than the outer diameter of the internal threaded anchor FIS IG.

Steel failure in the stress cross-section of the FIS IG and the bolt against the yield point and composite failure in the lateral surface are taken into account.

Any failure of the timber cross-section, e.g. transverse tensile failure, must be checked separately.

Only use non-corroding FIS IG with non-corroding screws and FIS IG made of gvz. with screws made of gvz.

Minimum screw-in depth of the screws in the FIS IG in accordance with Z-9.1-914.

Partial safety factors  $\gamma_{M,H} = 1.3$ ;  $\gamma_{M,S} = 1.25$ ;  $\gamma_{F,global} = 1.4$  and  $k_{mod} = 0.9$  from KLED short and NKL 1+2 taken into account.

Values valid for glued laminated timber  $\geq$  GL24h. Higher load-bearing capacities may be possible for higher strength classes.

For groups of steel bars, as well as for combined loading from tensile and shear loads, as well as for bending stress, see Z-9.1-914 and DIN EN 1995-1-1 / NA.

All mechanical values given must be considered in relation to the assumptions made and are examples of dimensioning.

This is a planning aid. Projects must be dimensioned exclusively by structural engineers!

All values are subject to typesetting and printing errors.

# Loads FIS EM Plus under shear load

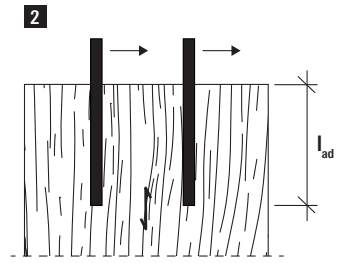
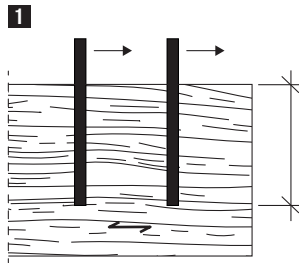
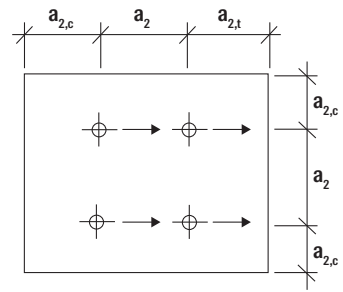
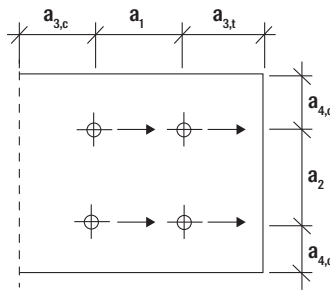
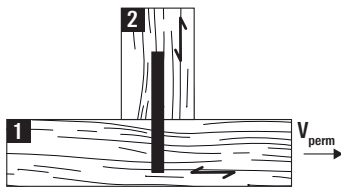

## Injection system FIS EM Plus with anchor rod FIS A

Permissible shear loads of a single anchor rod in glued laminated timber components  $\geq$  GL24h in a wood-/wood-connection

Anchor rods glued in parallel on one side (component 2) and perpendicular to the grain direction of the timber component (component 1) on the other side

For the design, the entire approval Z-9.1-914 and DIN EN 1995-1-1:2010-12 / NA must be observed.

Type	Material/ surface	Gluing length in component 1 (perpen- dicular to the fiber)	Gluing length in component 2 (parallel to the fiber)	Permissi- ble shear load	Minimum spacing	Minimum edge distance (unloa- ded) Component 2	Minimum edge distance (loaded) Component 2	Minimum lateral edge distance (unloa- ded) Component 1	Minimum endgrain edge distance (unloa- ded) Component 1	Minimum endgrain edge distance (loaded) Component 1	Minimum component dimen- sions Component 1	Minimum component dimen- sions Component 2
	[-]	$l_{ad,1}$ [mm]	$l_{ad,2}$ [mm]	$V_{perm}$ [kN]	$a_1 = a_2$ [mm]	$a_{2,c}$ [mm]	$a_{2,t}$ [mm]	$a_{4,c}$ [mm]	$a_{3,c}$ [mm]	$a_{3,t}$ [mm]	$b_1 / d_1$ [mm]	$b_2 / d_2$ [mm]
FIS A M 6	5.8	100	240	0.7	30	15	24	18	40	80	36 / 120	30 / 39
	8.8	100	240	0.9	30	15	24	18	40	80	36 / 120	30 / 39
	R-70	100	240	0.8	30	15	24	18	40	80	36 / 120	30 / 39
FIS A M 8	5.8	100	320	1.1	40	20	32	24	40	80	40 / 120	40 / 52
	8.8	100	320	1.4	40	20	32	24	40	80	40 / 120	40 / 52
	R-70	100	320	1.3	40	20	32	24	40	80	40 / 120	40 / 52
FIS A M 10	5.8	100	400	1.7	50	25	40	30	40	80	50 / 120	50 / 65
	8.8	100	400	2.1	50	25	40	30	40	80	50 / 120	50 / 65
	R-70	100	400	1.9	50	25	40	30	40	80	50 / 120	50 / 65
FIS A M 12	5.8	120	480	2.3	60	30	48	36	42	84	60 / 140	60 / 78
	8.8	120	480	2.8	60	30	48	36	42	84	60 / 140	60 / 78
	R-70	120	480	2.6	60	30	48	36	42	84	60 / 140	60 / 78
FIS A M 16	5.8	160	640	3.7	80	40	64	48	56	112	80 / 180	80 / 104
	8.8	160	640	4.5	80	40	64	48	56	112	80 / 180	80 / 104
	R-70	160	640	4.2	80	40	64	48	56	112	80 / 180	80 / 104
FIS A M 20	5.8	200	800	5.2	100	50	80	60	70	140	100 / 220	100 / 130
	8.8	200	800	6.5	100	50	80	60	70	140	100 / 220	100 / 130
	R-70	200	800	6.1	100	50	80	60	70	140	100 / 220	100 / 130
FIS A M 24	5.8	240	960	7.0	120	60	96	72	84	168	120 / 260	120 / 156
	8.8	240	960	8.6	120	60	96	72	84	168	120 / 260	120 / 156
	R-70	240	960	8.1	120	60	96	72	84	168	120 / 260	120 / 156
FIS A M 30	5.8	300	1000	9.8	150	75	120	90	105	210	150 / 320	150 / 195
	8.8	300	1000	12.1	150	75	120	90	105	210	150 / 320	150 / 195
	R-70	300	1000	11.3	150	75	120	90	105	210	150 / 320	150 / 195

### Notes:

Drill diameter in the wood 4 mm larger than the outer diameter of the steel rods.

Partial safety factors  $\gamma_{M,H} = 1.3$ ;  $\gamma_{M,S} = 1.25$ ;  $\gamma_{F,global} = 1.4$  and  $k_{mod} = 0.9$  from KLED short and NKL 1+2 taken into account.

Values valid for glued laminated timber  $\geq$  GL24h. Higher load-bearing capacities may be possible for higher strength classes.

Possible failure of the timber cross-section such as transverse tensile failure and block shear failure must be checked separately!

For groups of steel bars, as well as for combined loading from tensile and shear loads, as well as for bending loads, see Z-9.1-914 and DIN EN 1995-1-1 / NA.

All specified mechanical values must be considered depending on the assumptions made and represent design examples.

This is a planning aid. Projects must be dimensioned exclusively by structural engineers!

All values are subject to typesetting and printing errors.

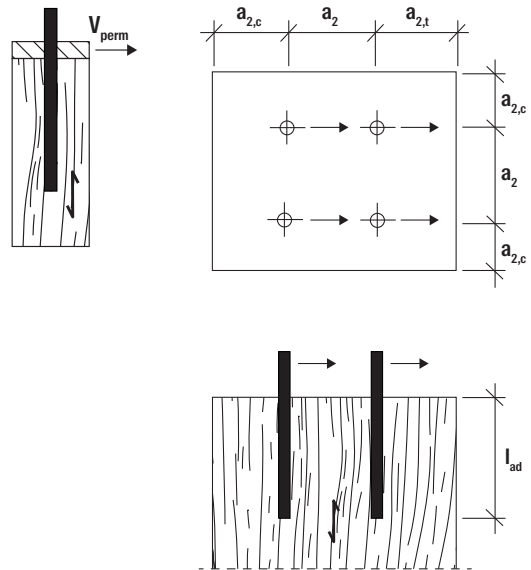

Injection system FIS EM Plus with anchor rod FIS A

Permissible shear loads of a single anchor rod in glued laminated timber components  $\geq$  GL24h in a steel / timber connection  
 Anchor rods glued in parallel to the grain direction of the timber component  
 For the design, the entire approval Z-9.1-914 and DIN EN 1995-1-1:2010-12 / NA must be observed.

Type	Material/surface [-]	Gluing length		Permissible shear load (thin steel attachment part) $t \leq 0,5 \cdot d$	Permissible shear load (thick steel attachment part) $t \geq d^0$	Minimum spacing	Minimum edge distance (unloaded)	Minimum edge distance (loaded)	Minimum component dimensions
		$l_{ad}$ [mm]	$V_{perm}$ [kN]	$V_{perm}$ [kN]	$a_2$ [mm]	$a_{2,c}$ [mm]	$a_{2,t}$ [mm]	$b / d$ [mm]	
FIS A M 6	5.8	100	0.4	0.7	30	15	24	30 / 39	
	5.8	240	0.6	0.9	30	15	24	30 / 39	
	8.8	100	0.4	0.8	30	15	24	30 / 39	
	8.8	240	0.8	1.1	30	15	24	30 / 39	
	R-70	100	0.4	0.8	30	15	24	30 / 39	
	R-70	240	0.7	1.0	30	15	24	30 / 39	
FIS A M 8	5.8	100	0.6	1.0	40	20	32	40 / 52	
	5.8	320	1.0	1.4	40	20	32	40 / 52	
	8.8	100	0.6	1.2	40	20	32	40 / 52	
	8.8	320	1.3	1.8	40	20	32	40 / 52	
	R-70	100	0.6	1.1	40	20	32	40 / 52	
	R-70	320	1.2	1.7	40	20	32	40 / 52	
FIS A M 10	5.8	100	0.7	1.4	50	25	40	50 / 65	
	5.8	400	1.5	2.1	50	25	40	50 / 65	
	8.8	100	0.7	1.7	50	25	40	50 / 65	
	8.8	400	1.9	2.7	50	25	40	50 / 65	
	R-70	100	0.7	1.6	50	25	40	50 / 65	
FIS A M 12	R-70	400	1.8	2.5	50	25	40	50 / 65	
	5.8	120	1.0	2.0	60	30	48	60 / 78	
	5.8	480	2.1	3.0	60	30	48	60 / 78	
	8.8	120	1.0	2.4	60	30	48	60 / 78	
	8.8	480	2.6	3.7	60	30	48	60 / 78	
	R-70	120	1.0	2.2	60	30	48	60 / 78	
R-70	480	2.4	3.5	60	30	48	60 / 78		



Type	Material/surface [-]	Gluing length $l_{ad}$ [mm]	Permissible shear load (thin steel attachment part) $t \leq 0,5 \cdot d$ $V_{perm}$ [kN]	Permissible shear load (thick steel attachment part) $t \geq d^1$ $V_{perm}$ [kN]	Minimum spacing $a_2$ [mm]	Minimum edge distance (unloaded) $a_{2,c}$ [mm]	Minimum edge distance (loaded) $a_{2,t}$ [mm]	Minimum component dimensions $b / d$ [mm]
FIS A M 16	5.8	160	1.8	3.4	80	40	64	80 / 104
	5.8	640	3.5	4.9	80	40	64	80 / 104
	8.8	160	1.8	3.9	80	40	64	80 / 104
	8.8	640	4.3	6.1	80	40	64	80 / 104
	R-70	160	1.8	3.8	80	40	64	80 / 104
	R-70	640	4.0	5.7	80	40	64	80 / 104
FIS A M 20	5.8	200	2.7	5.0	100	50	80	100 / 130
	5.8	800	5.1	7.2	100	50	80	100 / 130
	8.8	200	2.7	5.8	100	50	80	100 / 130
	8.8	800	6.3	9.0	100	50	80	100 / 130
	R-70	200	2.7	5.6	100	50	80	100 / 130
	R-70	800	5.9	8.4	100	50	80	100 / 130
FIS A M 24	5.8	240	3.7	6.9	120	60	96	120 / 156
	5.8	960	6.9	9.8	120	60	96	120 / 156
	8.8	240	3.8	8.0	120	60	96	120 / 156
	8.8	960	8.6	12.2	120	60	96	120 / 156
	R-70	240	3.8	7.6	120	60	96	120 / 156
	R-70	960	8.1	11.4	120	60	96	120 / 156
FIS A M 30	5.8	300	5.5	10.0	150	75	120	150 / 195
	5.8	1000	10.0	14.2	150	75	120	150 / 195
	8.8	300	5.5	11.5	150	75	120	150 / 195
	8.8	1000	12.5	17.6	150	75	120	150 / 195
	R-70	300	5.5	11.0	150	75	120	150 / 195
	R-70	1000	11.7	16.5	150	75	120	150 / 195

<sup>1)</sup> Tolerance of the hole diameter in the steel part must be  $\leq 0.1 \cdot d$  in accordance with DIN EN 1995-1-1

#### Notes:

Drill diameter in the wood 4 mm larger than the outer diameter of the steel rods.

Partial safety factors  $\gamma_{M,H} = 1.3$ ;  $\gamma_{M,S} = 1.25$ ;  $\gamma_{F,global} = 1.4$  and  $k_{mod} = 0.9$  from KLED short and NKL 1+2 taken into account.

Values valid for glued laminated timber  $\geq$  GL24h. Higher load-bearing capacities may be possible for higher strength classes.

Possible failure of the timber cross-section such as transverse tensile failure and block shear failure must be checked separately!

For groups of steel bars, as well as for combined loading from tensile and shear loads, as well as for bending loads, see Z-9.1-914 and DIN EN 1995-1-1 / NA.

All specified mechanical values must be considered depending on the assumptions made and represent design examples.

This is a planning aid. Projects must be dimensioned exclusively by structural engineers!

All values are subject to typesetting and printing errors.

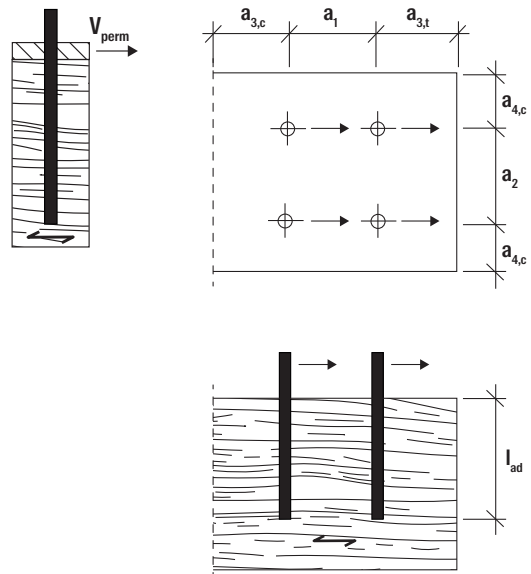

**Injection system FIS EM Plus with anchor rod FIS A**

Permissible shear loads of a single anchor rod in glued laminated timber components  $\geq$  GL24h in a steel / timber connection  
 Anchor rods bonded perpendicular to the grain direction of the timber component  
 For the design, the entire approval Z-9.1-914 and DIN EN 1995-1-1:2010-12 / NA must be observed.

Type	Material/ surface	Gluing length  $l_{ad}$ [mm]	Permissible shear load (thin steel attachment part) $t \leq 0,5 \cdot d$	Permissible shear load (thick steel attachment part) $t \geq d^0$	Minimum spacing in fiber direction	Minimum spacing perpendicular ar to the fiber	Minimum lateral edge distance (unloaded)	Minimum edge distan- ce end grain (loaded)	Minimum edge distan- ce end grain (unloaded)	Minimum component dimensions
			$V_{perm}$ [kN]	$V_{perm}$ [kN]	$a_1$ [mm]	$a_2$ [mm]	$a_{4,c}$ [mm]	$a_{3,t}$ [mm]	$a_{3,ct}$ [mm]	$b / d$ [mm]
FIS A M 6	5.8	100	1.9	2.7	30	30	18	80	40	36 / 120
	5.8	240	1.9	2.7	30	30	18	80	40	36 / 260
	8.8	100	2.4	3.4	30	30	18	80	40	36 / 120
	8.8	240	2.4	3.4	30	30	18	80	40	36 / 260
	R-70	100	2.2	3.2	30	30	18	80	40	36 / 120
	R-70	240	2.2	3.2	30	30	18	80	40	36 / 260
FIS A M 8	5.8	100	3.2	4.6	40	36	24	80	40	48 / 120
	5.8	320	3.2	4.6	40	36	24	80	40	48 / 340
	8.8	100	4.0	5.7	40	36	24	80	40	48 / 120
	8.8	320	4.0	5.7	40	36	24	80	40	48 / 340
	R-70	100	3.8	5.3	40	36	24	80	40	48 / 120
	R-70	320	3.8	5.3	40	36	24	80	40	48 / 340
FIS A M 10	5.8	100	4.8	6.8	50	42	30	80	40	60 / 120
	5.8	400	4.8	6.8	50	42	30	80	40	60 / 420
	8.8	100	6.0	8.3	50	42	30	80	40	60 / 120
	8.8	400	6.0	8.4	50	42	30	80	40	60 / 420
	R-70	100	5.6	7.9	50	42	30	80	40	60 / 120
	R-70	400	5.6	7.9	50	42	30	80	40	60 / 420
FIS A M 12	5.8	120	6.6	9.4	60	48	36	84	42	72 / 140
	5.8	480	6.6	9.4	60	48	36	84	42	72 / 500
	8.8	120	8.2	11.6	60	48	36	84	42	72 / 140
	8.8	480	8.3	11.7	60	48	36	84	42	72 / 500
	R-70	120	7.7	10.9	60	48	36	84	42	72 / 140
	R-70	480	7.7	10.9	60	48	36	84	42	72 / 500

Type	Material/ surface	Gluing length	Permissible shear load (thin steel attachment part) $t \leq 0,5 \cdot d$	Permissible shear load (thick steel attachment) $t \geq d^1)$	Minimum spacing in fiber direction	Minimum center distance perpendicular to the fiber	Minimum lateral edge distance (unloaded)	Minimum edge distance end grain (loaded)	Minimum edge distance end grain (unloaded)	Minimum component dimensions
	[-]	$l_{ad}$ [mm]	$V_{perm}$ [kN]	$V_{perm}$ [kN]	$a_1$ [mm]	$a_2$ [mm]	$a_{4,c}$ [mm]	$a_{3,t}$ [mm]	$a_{3,ct}$ [mm]	$b/d$ [mm]
FIS A M 16	5.8	160	11.0	15.5	80	60	48	112	56	96 / 180
	5.8	640	11.0	15.5	80	60	48	112	56	96 / 660
	8.8	160	13.6	19.3	80	60	48	112	56	96 / 180
	8.8	640	13.6	19.3	80	60	48	112	56	96 / 660
	R-70	160	12.8	18.1	80	60	48	112	56	96 / 180
	R-70	640	12.8	18.1	80	60	48	112	56	96 / 660
FIS A M 20	5.8	200	16.1	22.8	100	72	60	140	70	120 / 220
	5.8	800	16.1	22.8	100	72	60	140	70	120 / 820
	8.8	200	20.0	28.3	100	72	60	140	70	120 / 220
	8.8	800	20.0	28.3	100	72	60	140	70	120 / 820
	R-70	200	18.8	26.5	100	72	60	140	70	120 / 220
	R-70	800	18.8	26.6	100	72	60	140	70	120 / 820
FIS A M 24	5.8	240	21.9	31.0	120	84	72	168	84	144 / 260
	5.8	960	22.0	31.1	120	84	72	168	84	144 / 980
	8.8	240	27.3	38.6	120	84	72	168	84	144 / 260
	8.8	960	27.3	38.6	120	84	72	168	84	144 / 980
	R-70	240	25.6	36.2	120	84	72	168	84	144 / 260
	R-70	960	25.6	36.2	120	84	72	168	84	144 / 980
FIS A M 30	5.8	300	31.7	44.8	150	102	90	210	105	180 / 320
	5.8	1000	31.7	44.9	150	102	90	210	105	180 / 1020
	8.8	300	39.4	55.7	150	102	90	210	105	180 / 320
	8.8	1000	39.4	55.8	150	102	90	210	105	180 / 1020
	R-70	300	36.9	52.2	150	102	90	210	105	180 / 320
	R-70	1000	37.0	52.3	150	102	90	210	105	180 / 1020

<sup>1)</sup> Tolerance of the hole diameter in the steel part must be  $\leq 0.1 \cdot d$  in accordance with DIN EN 1995-1-1

#### Notes:

Drill diameter in the wood 4 mm larger than the outer diameter of the steel rods.

Partial safety factors  $\gamma_{M,H} = 1.3$ ;  $\gamma_{M,S} = 1.25$ ;  $\gamma_{F,global} = 1.4$  and  $k_{mod} = 0.9$  from KLED short and NKL 1+2 taken into account.

Values valid for glued laminated timber  $\geq$  GL24h. Higher load-bearing capacities may be possible for higher strength classes.

Possible failure of the timber cross-section such as transverse tensile failure and block shear failure must be checked separately!

For groups of steel bars, as well as for combined loading from tensile and shear loads, as well as for bending loads, see Z-9.1-914 and DIN EN 1995-1-1 / NA.

All specified mechanical values must be considered depending on the assumptions made and represent design examples.

This is a planning aid. Projects must be dimensioned exclusively by structural engineers!

All values are subject to typesetting and printing errors.