

Technical Datasheet

FES-C-40/25 anchor channel

Advantages



- Economical cold-formed Cast-in Channels combining high loading capacity and safety.
- Two directional load capacity: tension and shear perpendicular to the channel axis.
- Ideal prepositioned fixing solution, capable of covering on-site tolerances.
- Suitable for applications in cracked and non-cracked concrete.
- Permanently adjustable fixing solution.

Technical Data

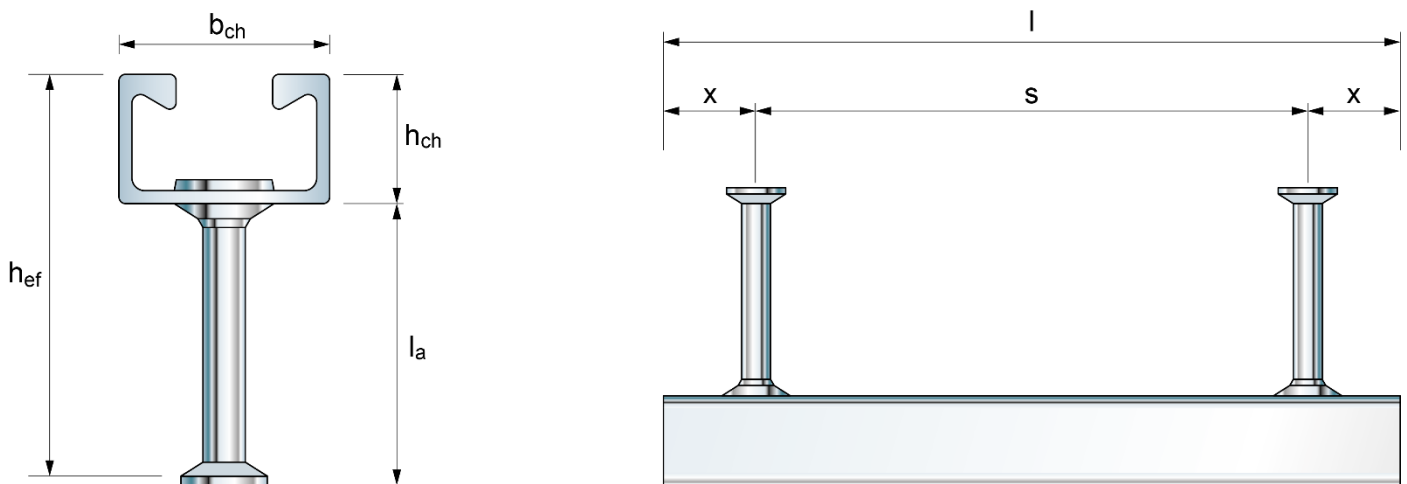

Effective embedment depth	Total embedment depth	Minimum thickness of concrete	Anchor length	Height	Width	Overhang	Anchor spacing
h_{ef}	$h_{nom} (l_a + h_{ch})$	h_{min}	l_a	h_{ch}	b_{ch}	x	s
79 mm	78,1 mm	100 mm	56,0 mm	25 mm	40 mm	25-35 mm	100-250 mm

Product Information

Item	Item no.	Length l [mm]	Number of anchors	Anchor spacing s [mm]	Match	Thread M	Sales units [pcs]
FES-C-40/25-150-HDG	552567	150	2	100	FBC-40/22	M10-M16	1
FES-C-40/25-200-HDG	552568	200	2	150	FBC-40/22	M10-M16	1
FES-C-40/25-250-HDG	552569	250	2	200	FBC-40/22	M10-M16	1
FES-C-40/25-300-HDG	552570	300	2	250	FBC-40/22	M10-M16	1
FES-C-40/25-350-HDG	552571	350	3	150	FBC-40/22	M10-M16	1
FES-C-40/25-400-HDG	552572	400	3	175	FBC-40/22	M10-M16	1
FES-C-40/25-550-HDG	552573	550	3	250	FBC-40/22	M10-M16	1
FES-C-40/25-800-HDG	552574	800	4	250	FBC-40/22	M10-M16	1
FES-C-40/25-1050-HDG	552575	1050	5	250	FBC-40/22	M10-M16	1
FES-C-40/25-3050-HDG	552576	3050	13	250	FBC-40/22	M10-M16	1
FES-C-40/25-6070-HDG	552577	6070	25	250	FBC-40/22	M10-M16	1

- all Cast-In Channel FES-C-40/25 with hot-dip galvanized coating, Anchor Diameter $d_s=8$ mm
 - different lengths and curved Cast-In channels available on request



European Technical Assessment
 ETA-18/0862
 EAD-330008-03-0601



CHANNEL-FIX
 FIXperience Software



Fire resistance



Static 2D loading



Website