

ICC-ES Evaluation Report

ESR-2691

Reissued April 2025

This report also contains:

- [CA Supplement](#)

Subject to renewal April 2027

ICC-ES Evaluation Reports are not to be construed as representing aesthetics or any other attributes not specifically addressed, nor are they to be construed as an endorsement of the subject of the report or a recommendation for its use. There is no warranty by ICC Evaluation Service, LLC, express or implied, as to any finding or other matter in this report, or as to any product covered by the report.

Copyright © 2025 ICC Evaluation Service, LLC. All rights reserved.

<p>DIVISION: 03 00 00— CONCRETE</p> <p>Section: 03 16 00— Concrete Anchors</p> <p>DIVISION: 05 00 00— METALS</p> <p>Section: 05 05 19—Post- Installed Concrete Anchors</p>	<p>REPORT HOLDER:</p> <p>fischerwerke GmbH & CO. KG</p>	<p>EVALUATION SUBJECT:</p> <p>fischer FH II CARBON STEEL HEAVY DUTY SLEEVE ANCHOR FOR ANCHORING IN CRACKED AND UNCRAKED CONCRETE</p>	
---	--	--	---

1.0 EVALUATION SCOPE

Compliance with the following codes:

- 2021, 2018, 2015, 2012, and 2009 [International Building Code® \(IBC\)](#)
- 2021, 2018, 2015, 2012, and 2009 [International Residential Code® \(IRC\)](#)
- 2013 *Abu Dhabi International Building Code (ADIBC)*[†]

[†]The ADIBC is based on the 2009 IBC. 2009 IBC code sections referenced in this report are the same sections in the ADIBC.

Property evaluated:

- Structural

2.0 USES

The fischer FH II Carbon Steel Heavy Duty Sleeve Anchor is used as anchorage to resist static, wind and seismic tension and shear loads in cracked and uncracked normal-weight and lightweight concrete having a specified compressive strength, f'_c , of 2,500 psi to 8,500 psi (17.2 MPa to 58.6 MPa) [minimum of 24 MPa is required under ADIBC Appendix L, Section 5.1.1].

The fischer FH II anchors comply as anchors installed in hardened concrete in accordance with Section 1901.3 of the 2021, 2018 and 2015 IBC, Section 1909 of the 2012 IBC, Section 1912 of the 2009 IBC. The fischer FH II anchors are an alternative to cast-in-place anchors described in Section 1901.3 of the 2021, 2018 and 2015 IBC, Section 1908 and 1909 of the 2012 IBC, and Section 1911 and 1912 of the 2009 IBC. The anchors may also be used where an engineered design is submitted in accordance with Section R301.1.3 of the IRC.

3.0 DESCRIPTION

3.1 FH II Carbon Steel Heavy Duty Sleeve Anchor:

3.1.1 General: The fischer FH II Carbon Steel Heavy Duty Sleeve Anchor, designated as the FH II, is a torque-controlled, sleeve-type mechanical expansion anchor. The components, dimensions and installation criteria are set forth in [Tables 1, 2 and 4](#), and [Figures 1, 2 and 3](#) of this report. Four head configurations are available: Version S, Version B, Version H and Version SK. The head configurations are illustrated in [Figure 3](#). All carbon steel parts have a minimum 0.0002 inch (5 µm) thick galvanized zinc coating according to DIN EN ISO 4042.

Application of torque at the head of the anchor causes the cone to be drawn into the expansion sleeve. This cone movement in turn causes the expansion sleeve to expand against the wall of the drilled hole. The ribs on the collapsible sleeve prevent rotation of the expansion sleeve and cone during application of torque. Application of the specified installation torque induces a tension force in the concrete acting through the component being fastened. Telescopic deformation of the collapsible sleeve prevents buildup of pre-compression in the expansion sleeve in cases where the steel sleeve is in contact with the washer, and permits the closure of gaps between the work surface and the component being fastened. Application of tension loads that exceed the pre-compression force in the anchor will cause the cone to displace further into the expansion sleeve (follow-up expansion), generating additional expansion force.

3.1.2 FH II S (Hexagonal Screw Version): The anchor consists of an ISO 898-1, Class 8.8 hexagonal screw, steel washer, steel sleeve, collapsible plastic sleeve, steel expansion sleeve and steel cone. This anchor is available in carbon steel only. The material specifications are as follows:

- Hexagonal screw: Carbon steel complying with ISO 898-1, Class 8.8
- Washer: Carbon steel complying with EN 10139.
- Expansion cone: Carbon steel complying with EN 10277.
- Expansion sleeve: Carbon steel complying with EN 10305.
- Steel sleeve: Carbon steel complying with EN 10305-1.
- Collapsible sleeve: Plastic blend of polymer complying with ISO 527-1 and ISO 527-2.

3.1.3 FH II B (Bolt Version with Threaded Rod): The FH II B has the same components and material specifications as the FH II S (hexagonal screw) except that the hexagonal screw is replaced by a carbon steel threaded rod complying with ISO 898-1 Class 8.8 and a carbon steel hexagonal nut complying with ISO 898-2.

3.1.4 FH II H (Hexagonal Cap Nut Version): The FH II H has the same components and material specifications as the FH II B (bolt) except that a carbon steel hexagonal cap nut complying with ISO 898-2 replaces the nut.

3.1.5 FH II SK (Countersunk Screw Version): The FH II SK has the same components and material specifications as the FH II S (hexagonal screw) except that the hexagonal screw head is configured for countersunk applications, is configured to accept a hexagonal Allen wrench, and is provided with a conical washer. The screw is formed from carbon steel complying with ISO 898-1 and the conical washer is formed from carbon steel complying with EN 10277.

3.2 Concrete:

Normal-weight and lightweight concrete must conform to Sections 1903 and 1905 of the IBC, as applicable.

4.0 DESIGN AND INSTALLATION

4.1 Strength Design:

4.1.1 General: Design strength of anchors complying with the 2021 IBC, as well as Section R301.1.3 of the 2021 IRC must be determined in accordance with ACI 318-19 Chapter 17 and this report.

Design strength of anchors complying with the 2018 and 2015 IBC, as well as Section R301.1.3 of the 2018 and 2015 IRC must be determined in accordance with ACI 318-14 Chapter 17 and this report.

Design strength of anchors complying with the 2012 IBC, as well as Section R301.1.3 of the 2012 IRC, must be in accordance with ACI 318-11 Appendix D and this report.

Design strength of anchors complying with the 2009 IBC as well as Section R301.1.3 of the 2009 IRC must be in accordance with ACI 318-08 Appendix D and this report.

Design parameters are based on the 2021 (ACI 318-19), 2018 and 2015 IBC (ACI 318-14) and the 2012 IBC (ACI 318-11) unless noted otherwise in Sections 4.1.1 through 4.1.12 of this report. The strength design of anchors must comply with ACI 318-19 17.5.1.2, ACI 318-14 17.3.1 or ACI 318-11 D.4.1, as applicable, except as required in ACI 318-19 17.10, ACI 318-14 17.2.3 or ACI 318-11 D.3.3, as applicable.

Strength reduction factors, ϕ , as given in ACI 318-19 17.5.3, ACI 318-14 Section 17.3.3 or ACI 318-11 D.4.3, as applicable, and noted in [Table 3](#) of this report, must be used for load combinations calculated in accordance with Section 1605.1 for the 2021 IBC, or Section 1605.2 of the 2018, 2015, 2012 and 2009 IBC, Section 5.3 of ACI 318-19 and ACI 318-14 or Section 9.2 of ACI 318-11 as applicable. Strength reduction factors, ϕ , as given in ACI 318-11 D.4.4 must be used for load combinations calculated in accordance with ACI 318-11 Appendix C.

The value of f'_c used in the calculations must be limited to 8,000 psi (55.2 MPa) maximum, in accordance with ACI 318-19 17.3.1, ACI 318-14 17.2.7 or ACI 318-11 D.3.7, as applicable.

4.1.2 Requirements for Static Steel Strength in Tension, N_{sa} : The nominal steel strength of a single anchor in tension must be calculated in accordance with ACI 318-19 17.6.1.2, ACI 318-14 17.4.1.2 or ACI 318 D.5.1.2, as applicable. The value of N_{sa} is given in [Table 3](#) of this report. Strength reduction factors, Φ , corresponding to ductile steel elements may be used for the FH II.

4.1.3 Requirements for Concrete Breakout Strength in Tension, N_{cb} and N_{cbg} : The nominal concrete breakout strength of a single anchor or group of anchors in tension, N_{cb} and N_{cbg} , respectively, must be calculated in accordance with ACI 318-19 17.6.2, ACI 318-14 17.4.2 or ACI 318-11 D.5.2, as applicable, with modifications as described in this section. The basic concrete breakout strength of a single anchor in tension, N_b , must be calculated according to ACI 318-19 17.6.2.2, ACI 318-14 17.4.2.2 or ACI 318-11 D.5.2.2, as applicable, using the values of k_{cr} and h_{ef} as given in [Table 3](#) of this report. The nominal concrete breakout strength in tension in regions where analysis indicates no cracking at service loads in accordance with ACI 318-19 17.6.2.5, ACI 318-14 17.4.2.6 or ACI 318-11 D.5.2.6, as applicable, shall be calculated with $\Psi_{cN} = 1.0$ and using the value of k_{uncr} as given in [Table 3](#) of this report.

4.1.4 Requirements for Critical Edge Distance, Splitting: In applications where $c < c_{ac}$ and supplemental reinforcement to control splitting of the concrete is not present, the concrete breakout strength in tension for uncracked concrete, calculated according to ACI 318-19 17.6.2, ACI 318-14 17.4.2 or ACI 318-11 D.5.2, must be further multiplied by the factor $\Psi_{cp,N}$ as given by the following equation:

$$\Psi_{cp,N} = \frac{c}{c_{ac}} \quad (\text{Eq-1})$$

whereby the factor $\Psi_{cp,N}$ need not to be taken as less than $\frac{1.5h_{ef}}{c_{ac}}$

For all other cases $\Psi_{cp,N} = 1.0$. In lieu of ACI 318-19 17.9.5, ACI 318-14 17.7.6 or ACI 318-11 D.8.6, as applicable, values for the critical edge distance, c_{ac} , provided in [Table 4](#) of this report, must be used.

4.1.5 Requirements for pullout strength in tension, N_{pn} : The nominal pullout strength of a single anchor in tension in accordance with ACI 318-19 17.6.3.1 and 17.6.3.2.1, ACI 318-14 17.4.3.1 and 17.4.3.2 or ACI 318-11 D.5.3.1 and D.5.3.2 as applicable, in cracked and uncracked concrete, $N_{p,cr}$ and $N_{p,uncr}$, respectively, does not need to be evaluated.

4.1.6 Requirements for Static Steel Strength in Shear, V_{sa} : In lieu of the value of the nominal steel strength values of V_{sa} as given in ACI 318-19 17.7.1.2, 318-14 17.5.1.2 or ACI 318-11, D.6.1.2, as applicable, in shear, the values of V_{sa} for single anchor given in [Table 3](#) of this report shall be used and not derived by calculation. Strength reduction factors, Φ , corresponding to ductile elements, may be used for the FH II.

4.1.7 Requirements for Static Concrete Breakout Strength in Shear V_{cb} or V_{cbg} : The nominal concrete breakout strength of a single anchor or group of anchors in shear, V_{cb} or V_{cbg} , respectively must be calculated in accordance with ACI 318-19 17.7.2.1, ACI 318-14 17.5.2 or ACI 318-11 D.6.2, as applicable, with modifications as described in this section. The basic concrete breakout strength of a single anchor in shear, V_b , must be calculated in accordance with ACI 318-19 17.7.2.2.1, ACI 318-14 17.5.2.2 or ACI 318-11 D.6.2.2, as applicable, using the value of l_e and d_a given in [Table 3](#) of this report.

4.1.8 Requirements for Static Concrete Pryout Strength in Shear V_{cp} or V_{cpg} : The nominal concrete pryout strength of a single anchor or group of anchors in shear, V_{cp} or V_{cpg} , must be calculated in accordance with ACI 318-19 17.7.3, ACI 318-14 17.5.3 or ACI 318-11 D.6.3, as applicable, modified by using the value of k_{cp} provided in [Table 3](#) of this report and the value of N_{cb} or N_{cbg} as calculated in accordance with Section 4.1.3 of this report.

4.1.9 Requirements for Minimum Member Thickness, Minimum Anchor Spacing and Minimum Edge Distance: In lieu of ACI 318-19 17.9.4, ACI 318-14 17.7.5 or ACI 318-11 D.8.5, as applicable, minimum member thickness, $h_{a,min}$, must comply with [Table 4](#) of this report. In lieu of ACI 318-19 17.9.2, ACI 318-14 17.7.1 and 17.7.3 or ACI 318-11 D8.1 and D.8.3, respectively, as applicable, minimum edge distance and minimum spacing, $c_{a,min}$ and $s_{a,min}$, must comply with [Table 4](#) of this report. Intermediate values between s_{min} and c_{min} can be calculated by linear interpolation. [Figures 4](#) through [7](#) of this report provide more detail.

4.1.10 Requirements for Seismic Design:

4.1.10.1 General: For load combinations including seismic, the design must be performed according to ACI 318-19 17.10, ACI 318-14 17.2.3 or ACI 318-11 D.3.3, as applicable. Modifications to ACI 318-19 17.10 and ACI 318-14 17.2.3 shall be applied under Section 1905.1.8 of the 2021, 2018 and 2015 IBC. For the 2012 IBC, Section 1905.1.9 shall be omitted. Modifications to ACI 318-08 D.3.3, shall be applied under Section 1908.1.9 of the 2009 IBC.

The nominal steel strength and the nominal concrete breakout strength for anchors in tension, and the nominal concrete breakout strength and pryout strength for anchors in shear, must be calculated according to ACI 318-19 17.6 and 17.7, ACI 318-14 17.4 and 17.5 or ACI 318-11 D.5 and D.6, respectively, taking into account the corresponding values in [Table 3](#) and [4](#) of this report. The anchors comply with ACI 318 (-19 and -14) 2.3 and ACI 318-11 D.1, as applicable, as ductile steel elements and must be designed in accordance with ACI 318-19 17.10.5, 17.10.6, 17.10.7 or 17.10.4, ACI 318-14 17.2.3.4, 17.2.3.5, 17.2.3.6 or 17.2.3.7; ACI 318-11 D.3.3.4, D.3.3.5, D.3.3.6 or D.3.3.7; ACI 318-08 D.3.3.4, D.3.3.5 or D.3.3.6, as applicable.

4.1.10.2 Seismic Tension: The nominal steel strength and nominal concrete breakout strength for anchors in tension must be calculated according to ACI 318-19 17.6.1 and 17.6.2, ACI 318-14 17.4.1 and 17.4.2 or ACI 318-11 D.5.1 and D.5.2, respectively, as applicable, as described in Sections 4.1.2 and 4.1.3 of this report and in accordance with ACI 318-19 17.6.3.2.1, ACI 318-14 17.4.3.2 or ACI 318-11 Section D.5.3.2, as applicable. The value for pullout strength in tension for seismic loads, N_{eq} , does not need to be evaluated.

4.1.10.3 Seismic Shear: The nominal concrete breakout strength and pryout strength for anchors in shear must be calculated according to ACI 318-19 17.7.2 and 17.7.3, ACI 318-14 17.5.2 and 17.5.3 or ACI 318-11 D.6.2 and D.6.3, respectively, as applicable, as described in Sections 4.1.7 and 4.1.8 of this report. In accordance with ACI 318-19 17.7.1.2, ACI 318-14 17.5.1.2 or ACI 318-11 D.6.1.2, as applicable, the appropriate value for nominal steel strength in shear for seismic loads, V_{eq} , described in [Table 3](#) of this report must be used in lieu of V_{sa} . Strength reduction factors, Φ , corresponding to ductile elements must be used for the FH II.

4.1.11 Requirements for Interaction of Tensile and Shear Forces: For loadings that include combined tension and shear, the design must be performed in accordance with ACI 318-19 17.8, ACI 318-14 17.6 or ACI 318-11 D.7, as applicable.

4.1.12 Lightweight Concrete: For the use of anchors in lightweight concrete, the modification factor λ_a equal to 0.8λ is applied to all values of $\sqrt{f'_c}$ affecting N_n and V_n .

For ACI 318-19 (2021 IBC), ACI 318-14 (2018 and 2015 IBC), ACI 318-11 (2012 IBC) and ACI 318-08 (2009 IBC), λ shall be determined in accordance with the corresponding version of ACI 318.

4.2 Allowable Stress Design (ASD):

4.2.1 General: Design values for use with allowable stress design load combinations calculated in accordance with Section 1605.1 of the 2021 IBC or Section 1605.3 of the 2018, 2015, 2012 and 2009 IBC must be established as follows:

$$T_{allowable,ASD} = \frac{\phi N_n}{\alpha} \quad (\text{Eq-2})$$

$$V_{allowable,ASD} = \frac{\phi V_n}{\alpha} \quad (\text{Eq-3})$$

where:

$$T_{allowable,ASD} = \text{Allowable tension load [lbf or kN]}$$

$$V_{allowable,ASD} = \text{Allowable shear load [lbf or kN]}$$

ϕN_n = Lowest design strength of an anchor or anchor group in tension as determined in accordance with ACI 318 (-19 and -14) Chapter 17 and 2021, 2018 and 2015 IBC Section 1905.1.8, ACI 318-11 Appendix D, ACI 318-08 Appendix D and 2009 IBC Section 1908.1.9 and Section 4.1 of this report, as applicable (lbf or N). For the 2012 IBC, Section 1905.1.9 shall be omitted.

ϕV_n = Lowest design strength of an anchor or anchor group in shear as determined in accordance with ACI 318 (-19 and -14) Chapter 17 and 2021, 2018 and 2015 IBC Section 1905.1.8, ACI 318-11 Appendix D, ACI 318-08 Appendix D and 2009 IBC Section 1908.1.9 and Section 4.1 of this report, as applicable (lbf or N). For the 2012 IBC, Section 1905.1.9 shall be omitted.

α = Conversion factor calculated as a weighted average of the load factors for the controlling load combination. In addition, α shall include all applicable factors to account for nonductile failure modes and required over-strength.

An example of allowable stress design values for illustrative purposes is shown in [Table 5](#) of this report.

4.2.2 Interaction of Tensile and Shear Forces: The interaction must be calculated in accordance and consistent with ACI 318-19 17.8, ACI 318-14 17.6 or ACI 318 (-11 and -08) D.7 as follows:

For shear loads $V \leq 0.2 V_{allowable,ASD}$, the full allowable load in tension $T_{allowable,ASD}$ must be permitted.

For tension loads $T \leq 0.2 T_{allowable,ASD}$, the full allowable load in shear $V_{allowable,ASD}$ must be permitted.

For all other cases Eq-4 applies:

$$\frac{T}{T_{allowable,ASD}} + \frac{V}{V_{allowable,ASD}} \leq 1.2 \quad (\text{Eq-4})$$

4.3 Installation:

Installation parameters are provided in [Tables 2](#) and [4](#) and in [Figure 2](#) of this report. Anchor locations must be in accordance with this report and the plans and specifications approved by the code official. The FH II anchors must be installed according to the manufacturer's published instructions and this report. In case of conflict, this report governs. Anchors must be installed in holes drilled into the concrete using carbide-tipped masonry drill bits complying with the requirements of [Table 2](#) of this report. The minimum drilled hole depth is given in [Table 2](#). The predrilled hole must be cleaned free of dust and debris using a hand pump, compressed air or vacuum. The anchor must be hammered into the predrilled hole until the proper nominal embedment depth is achieved. The anchor must be tightened against the washer until the torque values T_{inst} specified in [Table 2](#) of this report are achieved.

4.4 Special Inspection:

Periodic special inspection is required, in accordance with Section 1705.1.1 and Table 1705.3 of the 2021, 2018, 2015 or 2012 IBC, or section 1704.15 and Table 1704.4 of the 2009 IBC, as applicable. The special inspector must make periodic inspections during anchor installation to verify anchor type, anchor dimensions, concrete type, concrete compressive strength, hole dimensions, hole cleaning procedures, anchor spacing(s), edge distance(s), slab thickness, anchor embedment depth, tightening torque and adherence to the manufacturer's published installation instructions. The special inspector must be present as often as required in accordance with the "statement of special inspection". Under the IBC, additional requirements as set forth in Sections 1705, 1706 and 1707 must be observed, where applicable.

5.0 CONDITIONS OF USE:

The FH II anchors described in this report comply with, or are suitable alternatives to what is specified in, those codes listed in Section 1.0 of this report, subject to the following conditions:

- 5.1 Anchor sizes, dimensions and minimum embedment depths are as set forth in this report.
- 5.2 The anchors must be installed in accordance with the manufacturer's published installation instructions and this report. In case of a conflict, this report governs.
- 5.3 Anchors must be installed in cracked and uncracked normal-weight or lightweight concrete having a specified compressive strength, f'_c of 2,500 psi to 8,500 psi (17.2 MPa to 58.6 MPa) [minimum of 24 MPa is required under ADIBC Appendix L, Section 5.1.1].
- 5.4 The values of f'_c used for calculation purposes shall not exceed 8,000 psi (55.2 MPa).
- 5.5 Strength design values must be established in accordance with Section 4.1 of this report.
- 5.6 Allowable stress design values must be established in accordance with Section 4.2 of this report.

- 5.7 Anchor spacing(s) and edge distance(s) as well as minimum member thickness must comply with [Table 4](#) of this report.
- 5.8 Prior to installation, calculations and details demonstrating compliance with this report must be submitted to the code official. The calculations and details must be prepared by a registered design professional where required by the statutes of the jurisdiction in which the project is to be constructed.
- 5.9 Since an ICC-ES acceptance criteria for evaluating data to determine the performance of expansion anchors subjected to fatigue or shock loading is unavailable at this time, the use of these anchors under such conditions is beyond the scope of this report.
- 5.10 Anchors may be installed in regions of concrete where cracking has occurred or where analysis indicates cracking may occur ($f_t > f_{cr}$), subject to the conditions of this report.
- 5.11 Anchors may be used to resist short-term loading due to wind or seismic forces, subject to the conditions of this report.
- 5.12 Where not otherwise prohibited in the code, FH II anchors are permitted for use with fire-resistance-rated construction provided that at least one of the following conditions is fulfilled:
- Anchors are used to resist wind or seismic forces only.
 - Anchors that support a fire-resistance-rated envelope or a fire-resistance-rated membrane, are protected by approved fire-resistance-rated materials, or have been evaluated for resistance to fire exposure in accordance with recognized standards.
 - Anchors are used to support nonstructural elements.
- 5.13 Use of zinc-coated carbon steel anchors is limited to dry, interior locations.
- 5.14 Special inspection must be provided in accordance with Section 4.4 of this report.
- 5.15 Anchors are manufactured by fischerwerke, under an approved quality control program with inspections by ICC-ES.

6.0 EVIDENCE SUBMITTED

Data in accordance with the [ICC-ES Acceptance Criteria for Mechanical Anchors in Concrete Elements \(AC193\)](#), dated October 2017 (Editorially revised December 2020), which incorporates requirements in ACI 355.2 (-19 and -07) for use in cracked and uncracked concrete and quality control documentation.

7.0 IDENTIFICATION

- 7.1 The anchors can be identified on the packaging label with the manufacturer's name (fischer) and address, anchor name, anchor size and evaluation report number (ESR-2691). The "fish" symbol, the letters FH II, the anchor diameter and the maximum fixing thickness are stamped on each anchor.
- Example: ("fish") FH II 24/25 S, means 24 mm outer anchor diameter, 25 mm maximum thickness of fixture, S stands for Hexagonal Screw Version.
- 7.2 The report holder's contact information is the following:

fischerwerke GmbH & CO. KG
KLAUS-FISCHER-STRASSE 1
72178 WALDACHTAL
GERMANY
+49 (0) 7443 12-0
www.fischer-international.com

TABLE 1—ANCHOR DIMENSIONAL CHARACTERISTICS¹

Anchor Version ²	Nominal Bolt Diameter (mm)	d_{bit} (mm)	d_s (mm)	L_1 (mm)	t_{fix} ³ (mm)		l_1 (mm)	l_2 (mm)	l_3 (mm)	l_4 (mm)	t_{washer} (mm)
					Min.	Max.					
FH II S	M8	12	12.0	74	0	250	11	30	10	22	≥ 1.8
	M10	15	14.8	89	0	300	13	35.5	10.5	26.5	≥ 2.3
	M12	18	17.8	99	0	350	16	41	15	26.5	≥ 2.7
	M16	24	23.7	124	0	400	19	46	20	38	≥ 2.7
	M20	28	27.5	148	0	600	22.4	50	17.5	61.5	≥ 3.4
	M24	32	31.5	168	0	600	22.4	55	25	74	≥ 4.0
FH II B	M8	12	12.0	74	0	250	11	30	10	22	≥ 1.8
	M10	15	14.8	89	0	300	13	35.5	10.5	26.5	≥ 2.3
	M12	18	17.8	99	0	350	16	41	15	26.5	≥ 2.7
	M16	24	23.7	124	0	400	19	46	20	38	≥ 2.7
	M20	28	27.5	148	0	600	22.4	50	17.5	61.5	≥ 3.4
	M24	32	31.5	168	0	600	22.4	55	25	74	≥ 4.0
FH II H	M10	15	14.8	89	0	300	13	35.5	10.5	26.5	≥ 2.3
	M12	18	17.8	99	0	350	16	41	15	26.5	≥ 2.7
	M16	24	23.7	124	0	400	19	46	20	38	≥ 2.7
FH II SK	M10	15	14.8	89	6	300	13	35.5	10.5	26.5	0
	M12	18	17.8	99	6	350	16	41	15	26.5	0

For pound-inch units: 1 mm = 0.03937 inches

¹ Figure 1 describes location of dimensions. All dimensions are nominal excluding manufacturing tolerances.

² Figure 3 illustrates the available anchor versions.

³ Thickness applies to the attached fixture.

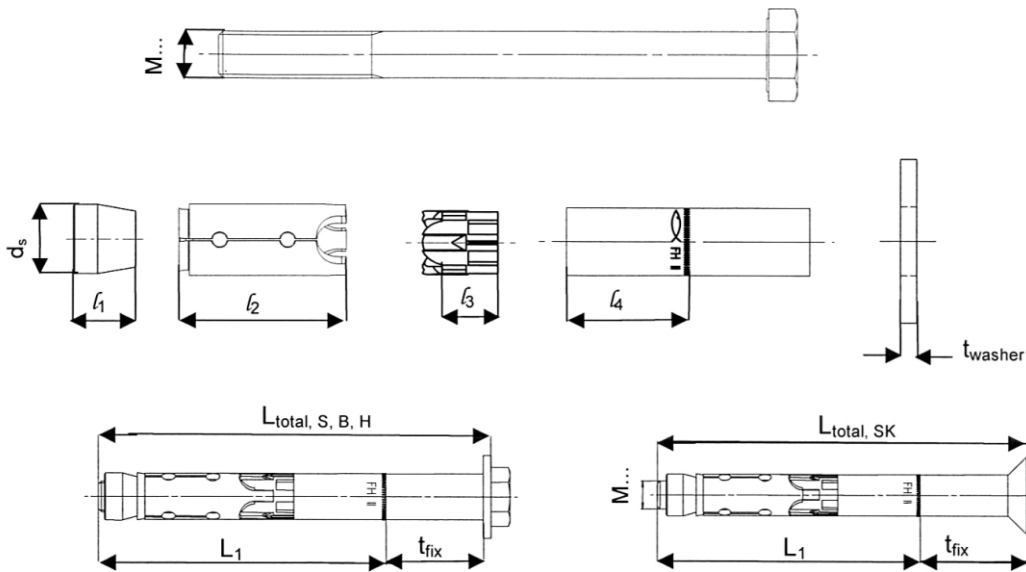

FIGURE 1—ANCHOR DIMENSIONAL CHARACTERISTICS

TABLE 2—INSTALLATION INFORMATION¹

Characteristic	Symbol	Units	Anchor Designation and Size						
			FH II 12 M8	FH II 15 M10	FH II 18 M12	FH II 24 M16	FH II 28 M20	FH II 32 M24	
Nominal drill hole diameter ²	d_{bit}	mm	12	15	18	24	28	32	
Cutting diameter of drill bit	$d_{bit,min}$	mm	12.10	15.10	18.10	24.10	28.10	32.15	
	$d_{bit,max}$	mm	12.50	15.50	18.50	24.55	28.55	32.70	
Minimum drill hole depth	$h_{1,min} \geq$	mm	80	90	105	125	155	180	
		in.	3.15	3.54	4.13	4.92	6.10	7.09	
Diameter of clearance hole in the fixture ⁴	$d_{f,S,H,B} \leq$	mm	14	17	20	26	31	35	
		in.	0.55	0.67	0.79	1.02	1.22	1.38	
Diameter of countersunk hole in the fixture	$d_{f,SK}$	mm	-	24.5	31.6	-	-	-	
		in.	-	0.97	1.25	-	-	-	
Required installation torque	Type S	T_{inst}	Nm	22.5	40	80	160	180	200
	Type SK			-	40	80	-	-	-
	Type H			-	40	80	90	-	-
	Type B			17.5	38	80	120	180	200
	Type S		16.6	29.5	59.0	118.0	132.8	147.5	
	Type SK		-	29.5	59.0	-	-	-	
	Type H		-	29.5	59.0	66.4	-	-	
	Type B		12.9	28.0	59.0	88.5	132.8	147.5	
Wrench size ³	Type S	-	mm	13	17	19	24	30	36
	Type SK			-	6	8	-	-	-
	Type H			-	17	19	24	-	-
	Type B			13	17	19	24	30	36
Washer Diameter	d_w	mm	≥ 20	≥ 24	≥ 28	≥ 36	≥ 40	≥ 46	
		in.	≥ 0.79	≥ 0.95	≥ 1.10	≥ 1.42	≥ 1.57	≥ 1.81	

For pound-inch units: 1 mm = 0.03937 inches, 1 Nm = 0.7376 ft-lbf.

¹All specifications excluding manufacturing tolerances.

²Only metric drill bits must be used.

³For Type SK Allen wrench size.

⁴Tolerances complying with ISO 273

Installation:

- Step 1: Using the correct metric bit diameter, d_{bit} (Table 2), drill hole to minimum required hole depth $h_{1,min}$ (Table 2) or deeper.
- Step 2: Remove drilling debris with a blowout bulb or with compressed air.
- Step 3: Using a hammer, tap the anchor through the part being fastened into the drilled hole until the washer is in contact with the fastened part. Do not expand anchor prior to installation.
- Step 4: Using a torque wrench, apply the specified installation torque T_{inst} (Table 2).

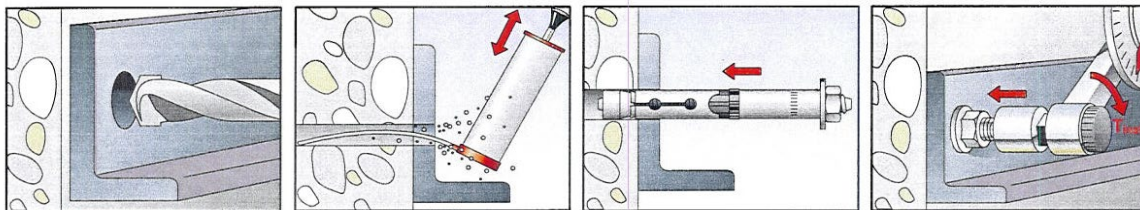

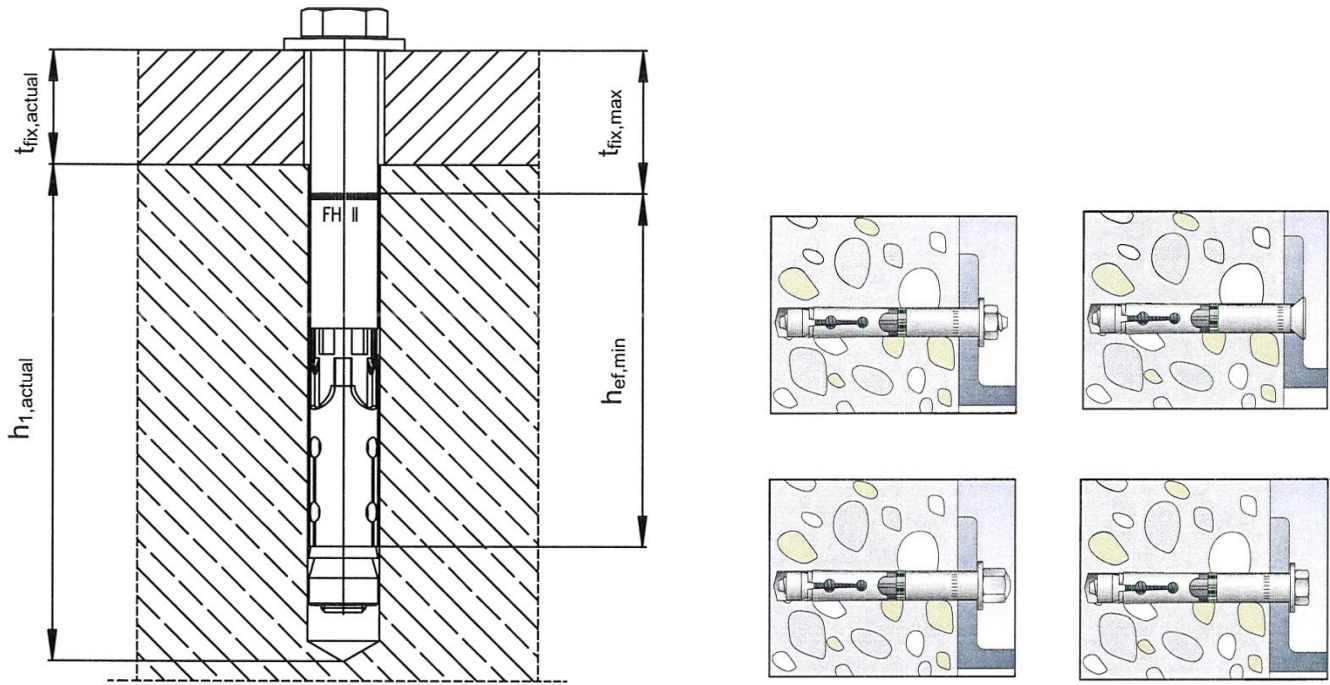

FIGURE 2—CORRECT INSTALLED ANCHOR

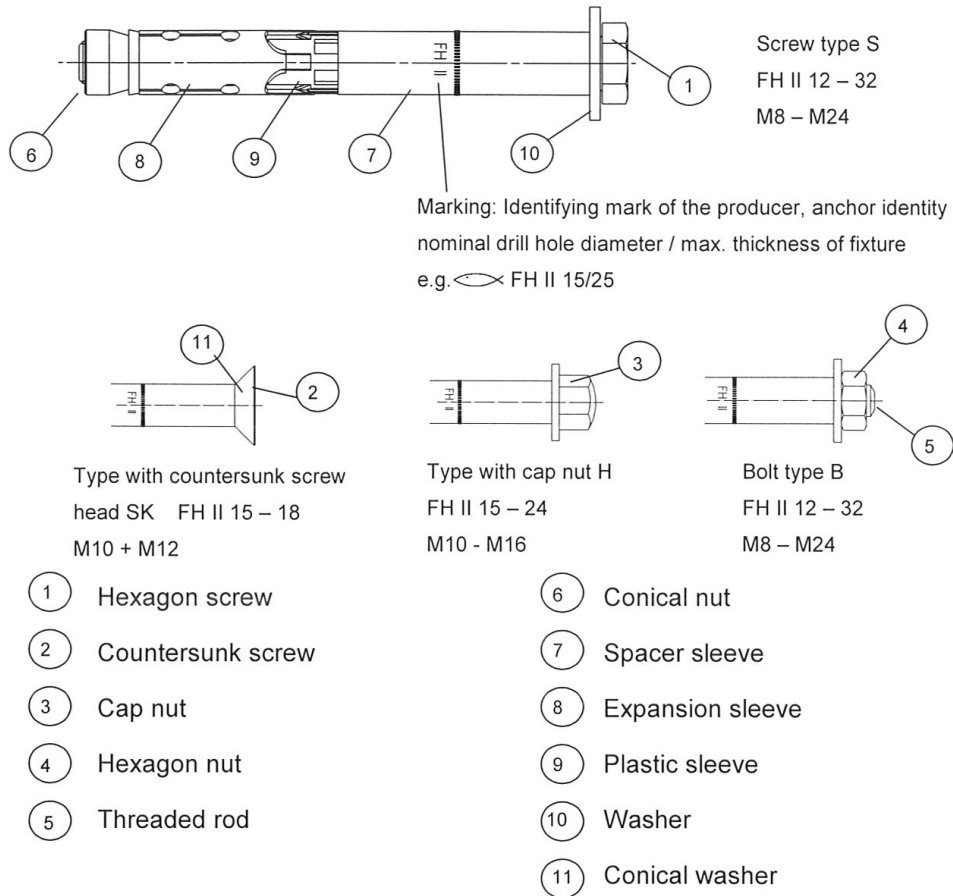

FIGURE 3—FH II HEAD CONFIGURATIONS

TABLE 3—DESIGN INFORMATION

Design parameter	Symbol	Units	Nominal anchor diameter FH II						
			M8	M10	M12	M16	M20	M24	
Outside diameter of anchor	d_a^8	mm	12	15	18	24	28	32	
		in.	0.47	0.59	0.71	0.94	1.10	1.26	
Effective min. embedment depth ¹	$h_{ef,min}$	mm	60	70	80	100	125	150	
		in.	2.36	2.76	3.15	3.94	4.92	5.91	
Anchor category ²	1,2 or 3	-	1	1	1	1	1	1	
Strength reduction factor for tension, steel failure modes ³	ϕ	-	0.75						
Strength reduction factor for shear, steel failure modes ³	ϕ	-	0.65						
Strength reduction factor for tension, concrete failure modes ^{4,5}	ϕ	-	0.75 (Condition A, supplementary reinforcement present)						
			0.65 (Condition B, supplementary reinforcement not present)						
Strength reduction factor for shear, concrete failure modes ^{4,5}	ϕ	-	0.75 (Condition A, supplementary reinforcement present)						
			0.70 (Condition B, supplementary reinforcement not present)						
Yield strength of anchor steel	f_{ya}	N/mm ²	640						
		lbf/in. ²	92,824						
Ultimate strength of anchor steel	f_{uta}	N/mm ²	800						
		lbf/in. ²	116,030						
Tensile stress area	A_{se}	mm ²	36.6	58.0	84.3	156.7	244.8	352.5	
		in. ²	0.057	0.090	0.131	0.243	0.379	0.546	
Steel strength in tension	N_{sa}	kN	29	46	67	125	196	282	
		lbf	6,516	10,337	15,056	28,090	44,045	63,370	
Effectiveness factor cracked concrete	k_{cr}	SI	7.1	8.8	8.8	10	10	10	
		Imp	17	21	21	24	24	24	
Effectiveness factor cracked concrete	k_{un-cr}	SI	11.3	11.3	11.3	12.6	12.6	12.6	
		Imp	27	27	27	30	30	30	
Additional effectiveness factor for uncracked concrete ⁶	$\psi_{c,N}$	-	1.0	1.0	1.0	1.0	1.0	1.0	
Pullout strength uncracked concrete ⁷	$N_{p,un-cr}$		not decisive						
Pullout strength cracked concrete ⁷	$N_{p,cr}$		not decisive						
Tension pullout strength seismic ⁷	N_{eq}		not decisive						
Steel strength in shear S, SK	V_{sa}	kN	33	59	76	146	174	217	
		lbf	7,419	13,264	17,085	32,822	39,117	48,784	
Steel strength in shear B, H	V_{sa}	kN	27	41	62	119	146	169	
		lbf	6,070	9,217	13,938	26,752	32,822	37,993	
Steel strength in shear, seismic S,SK	V_{eq}	kN	25	38	57	110	143	174	
		lb	5,620	8,543	12,814	24,729	32,148	39,117	
Steel strength in shear, seismic B,H	V_{eq}	kN	17	31	46	98	119	169	
		lb	3,822	6,969	10,341	22,031	26,752	37,993	
Coefficient for pryout strength	k_{cp}	[-]	1	2					
Effective length of anchor in shear loading	l_e	mm	24	30	36	48	56	64	
		in.	0.94	1.18	1.42	1.88	2.20	1.56	
Axial stiffness in service load range	cracked concrete	β_m	kN/mm	21	24	27	33	39	45
		β_m	10 ³ lbf/in	120	137	154	188	223	257
	uncracked concrete	β_m	kN/mm	65	91	118	171	224	277
		β_m	10 ³ lbf/in	371	520	674	976	1,279	1,582

¹Figure 2 illustrates the location of $h_{ef,min}$.²ACI 318-19 17.5.3, ACI 318-14 17.3.3 and ACI 318-11 D.4.3 and D4.4 set forth the permitted strength reduction factor ϕ based on anchor category.³The FH II anchors are considered as ductile steel element as defined by ACI 318(-19 and -14) 2.3 and ACI 318-11 D.1.⁴The strength reduction factor applies when the load combinations from the IBC or ACI 318 are used and the requirements of ACI 318-19 17.5.3, ACI 318-14 17.3.3 or ACI 318-11 D.4.3, as applicable, are met. If the load combinations of ACI 318-11 Appendix C are used, the appropriate strength reduction factor must be determined in accordance with ACI 318-11 D.4.4.⁵Anchors are permitted to be used in lightweight concrete provided that the provisions in accordance with Section 4.1.12 of this report are taken into account.⁶The value $\psi_{c,N} = 1.0$ for all design cases.⁷As described in Section 4.1.5 of this report, pullout resistance is not decisive.⁸All dimensions are nominal excluding manufacturing tolerances.

TABLE 4—EDGE DISTANCE, SPACING AND MEMBER THICKNESS REQUIREMENTS^{1,2}

Dimension	Symbol	Units	FH II 12 M8	FH II 15 M10	FH II 18 M12	FH II 24 M16	FH II 28 M20	FH II 32 M24
Minimum thickness of concrete member	$h_{a,min}$	[mm]	120	140	160	200	250	300
		[in.]	4.72	5.50	6.25	7.88	9.88	11.88
Minimum spacing ^{1,3}	$s_{a,min}$	[mm]	60	70	80	100	120	160
	for $c_{a2} \geq$	[mm]	100	120	160	220	240	380
Minimum spacing ^{1,3}	$s_{a,min}$	[in.]	2.36	2.76	3.15	3.94	4.72	6.30
	for $c_{a2} \geq$	[in.]	3.94	4.72	6.30	8.66	9.45	14.96
Minimum edge distance ^{1,3}	$c_{a,min}$	[mm]	60	70	80	100	120	180
	for $s_{a2} \geq$	[mm]	120	140	200	240	260	400
Minimum edge distance ^{1,3}	$c_{a,min}$	[in.]	2.36	2.76	3.15	3.94	4.72	7.09
	for $s_{a2} \geq$	[in.]	4.72	5.51	7.87	9.45	10.24	15.75
Critical edge distance ²	c_{ac}	[mm]	155	165	170	225	265	285
		[in.]	6.10	6.50	6.69	8.86	10.43	11.22

¹According to section 4.1.9 of this report.

²According to section 4.1.4 of this report.

³Intermediate values by linear interpolation.

TABLE 5—EXAMPLE ALLOWABLE STRESS DESIGN VALUES FOR ILLUSTRATIVE PURPOSES

Anchor type FH II S, SK, B, H	Effective Embedment depth h_{ef}	Allowable Tension Load
FH II 12 M8	2.36 in	2,150 lbf
	60 mm	9.57 kN
FH II 15 M10	2.76 in	2,719 lbf
	70 mm	12.05 kN
FH II 18 M12	3.15 in	3,315 lbf
	80 mm	14.73 kN
FH II 24 M16	3.94 in	5,152 lbf
	100 mm	22.77 kN
FH II 28 M20	4.92 in	7,189 lbf
	125 mm	31.82 kN
FH II 32 M24	5.91 in	9,465 lbf
	150 mm	41.83 kN

Design Assumptions:

¹Single anchor with static tension load only.

²Concrete determined to remain uncracked for the life of the anchorage.

³Load combinations from ACI 318 (-19 and -14) 5.3 or ACI 318-11 9.2 (no seismic loading).

⁴30% dead load and 70% live load, controlling load combination 1.2 D + 1.6 L.

⁵Calculation of weighted average for $\alpha = 0.3 \times 1.2 + 0.7 \times 1.6 = 1.48$.

⁶ $f'_c = 2,500$ psi (17.2 MPa) (normal weight concrete).

⁷ $c_{a1} = c_{a2} \geq c_{ac}$

⁸ $h \geq h_{min}$.

⁹Condition B according to ACI 318-19 17.5.3, ACI 318-14 17.3.3 or ACI 318-11 D.4.3(c), no supplementary reinforcement is present.

Given:

2 x FH II 12 S (M8)
 Slab on grade 5,076 psi
 No supplementary reinforcement
 (ACI 318-19 17.5.3)
 Assume cracked concrete
 $h_a = 4.72$ in.
 $h_{ef} = 2.36$ in.
 $s_a = 3.94$ in.
 $c_a = 3.15$ in.

Calculate the allowable static tension load for this configuration.

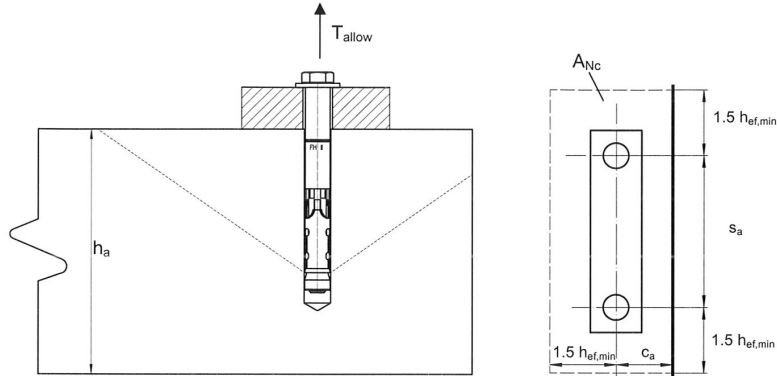

Calculation according to ACI 318-19 Chapter 17 and this report	ACI 318-19	Report Ref.
<p>Step 1. Verify minimum member thickness, spacing and edge distance:</p> <p>Table 4: $h_a = 4.72$ in. $\geq h_{a, min} = 4.72$ in. => ok</p> <p>slope: $(4.75 - 2.36) / (2.36 - 3.94) = -1.5$ For $c_a = 3.15$ in.</p> <p>$s_{min, calc} = [(3.15 - 3.94) \times (-1.5)] + 2.36 = 3.54$ in. $\leq s_a = 3.94$ => ok</p>	17.9	Table 4
<p>Step 2. Calculate steel strength of anchor in tension $N_{sa} = n N_s = 13,032$ lbf Calculate steel capacity $\phi N_{sa} = 0.75 \times 13,032 = 9,774$ lbf</p>	17.6.1.2 and 17.5.3 a)	Table 3
<p>Step 3. Calculate concrete breakout strength of anchor in tension</p> $N_{cbg} = \frac{A_{Nc}}{A_{Nco}} \times \psi_{ec, N} \times \psi_{ed, N} \times \psi_{c, N} \times \psi_{cp, N} \times N_b$	17.6.2.1 b)	§ 4.1.3 § 4.1.5
<p>Step 3a. Check $1.5 h_{ef} = 1.5 \times 2.36 = 3.54$ in. $> c_a$ $3.0 h_{ef} = 3.0 \times 2.36 = 7.08$ in. $> s_a$</p>	17.6.2.1 b)	Table 4
<p>Step 3b. Calculate A_{Nco} and A_{Nc} $A_{Nco} = 9 \times h_{ef}^2 = 9 \times (2.36)^2 = 50.13$ in.² $A_{Nc} = (1.5 h_{ef} + c_a) \times (3 h_{ef} + s_a) = [1.5 \times 2.36 + 3.15] \times [3 \times (2.36) + 3.94] = 73.72$ in.² $< 2 \times A_{Nco}$</p>	17.6.2.1 b)	Table 3
<p>Step 3c. Calculate $\psi_{ec, N}$: $e_N = 0 \Rightarrow \psi_{ec, N} = 1$</p>	17.6.2.3.1	-
<p>Step 3d. Calculate $N_b = k_{cr} \sqrt{f'_c} h_{ef}^{1.5} = 17 \times \sqrt{5,076} \times 2.36^{1.5} = 4,391$ lbf</p>	17.6.2.2	Table 3
<p>Step 3e. Calculate modification factor for edge distance:</p> $\psi_{ed, N} = 0.7 + 0.3 \frac{c_{a, min}}{1.5 \times h_{ef}} = 0.7 + 0.3 \times \frac{3.15}{1.5 \times 2.36} = 0.97 < 1$	17.6.2.4.1	Table 4
<p>Step 3f. $\psi_{c, N} = 1.0$ (cracked concrete)</p>	17.6.2.5.1	Table 3
<p>Step 3g. $\psi_{cp, N} = 1.0$</p>	17.6.2.6.1	Table 3
<p>Step 3h. Calculate $N_{cbg} = (73.72 / 50.13) \times 1 \times 0.97 \times 1 \times 4,391 = 6,264$ lbf</p>	17.6.2.1 b)	§ 4.1.1 Table 3
<p>Step 4. Controlling strength: $\phi N_{cbg} = 0.65 \times 6,264 = 4,071$ lbf $< \phi N_s = 9,774$ lbf</p>	17.5.3	Table 3
<p>Step 5. Calculate allowable stress design (30% dead load, 70% live load) $\alpha = 1.2 \times 0.3 + 1.6 \times 0.7 = 1.48 \rightarrow T_{allowable, ASD} = 4,071 / 1.48 = 2,751$ lbf</p>	Section 5.3	§ 4.2

FIGURE 4—EXAMPLE CALCULATION FOR TENSION CAPACITY (IMPERIAL UNITS)

<p>Given: 2 x FH II 12 S (M8) Slab on grade 35 MPa No supplementary reinforcement. (ACI 318-19 17.5.3) Assume cracked concrete $h_a = 120$ mm $h_{ef} = 60$ mm $s_a = 100$ mm $c_a = 80$ mm</p> <p>Calculate the allowable static and seismic tension load for this configuration.</p> 	
<p>Calculation according to ACI 318-19 Chapter 17 and this report</p>	<p>ACI 318-19</p>
<p>Step 1. Verify minimum spacing and edge distance: Table 4: $h_a = 120$ mm $\geq h_{a,min} = 120$ mm => ok</p> <p>Slope: $(120-60)/(60-100) = -1.5$</p> <p>For $c_a = 80$ mm</p> $s_{min,calc} = [(80-100) \times (-1.5)] + 60 = 90 \text{ mm} \leq s_a$ <p>=> ok</p> 	<p>Report Ref.</p> <p>17.9</p> <p>Table 4</p>
<p>Step 2. Calculate steel strength of anchor in tension $N_{sa} = n N_s = 58$ kN Calculate steel capacity $\phi N_s = 0.75 * 58 = 43.5$ kN</p>	<p>17.6.1.2 and 17.5.3</p> <p>Table 3</p>
<p>Step 3. Calculate concrete breakout strength of anchor in tension</p> $N_{cbg} = \frac{A_{Nc}}{A_{Nco}} \times \psi_{ec,N} \times \psi_{ed,N} \times \psi_{c,N} \times \psi_{cp,N} \times N_b$	<p>17.6.2.1 b)</p> <p>§ 4.1.1 § 4.1.2</p>
<p>Step 3a. Check $1.5 h_{ef} = 1.5 \times 60 = 90$ mm $> c_a$ $3.0 h_{ef} = 3.0 \times 60 = 180$ mm $> s_a$</p>	<p>17.6.2.1 b)</p> <p>Table 4</p>
<p>Step 3b. Calculate A_{Nco} and A_{Nc} $A_{Nco} = 9 \times h_{ef}^2 = 9 \times (60)^2 = 32,400$ mm² $A_{Nc} = (1.5 h_{ef} + c) \times (3 h_{ef} + s) = [1.5 \times 60 + 80] \times [3 \times (60) + 100] = 47,600$ mm² $< 2 \times A_{Nco}$</p>	<p>17.6.2.1 b)</p> <p>Table 3</p>
<p>Step 3c. Calculate $\psi_{ec,N}$: $e_N = 0 \Rightarrow \psi_{ec,N} = 1$</p>	<p>17.6.2.3.1</p> <p>-</p>
<p>Step 3d. Calculate $N_b = k_c \sqrt{f'_c} h_{ef}^{1.5} = 7 \times \sqrt{35} \times 60^{1.5} = 19,246$ N = 19.25 kN</p>	<p>17.6.2.2</p> <p>Table 3</p>
<p>Step 3e. Calculate modification factor for edge distance:</p> $\psi_{ed,N} = 0.7 + 0.3 \frac{c_{a,min}}{1.5 \times h_{ef}} = 0.7 + 0.3 \times \frac{80}{1.5 \times 60} = 0.97 < 1$	<p>17.6.2.4.1</p> <p>Table 4</p>
<p>Step 3f. $\psi_{c,N} = 1.0$ (cracked concrete)</p>	<p>17.6.2.5.1</p> <p>Table 3</p>
<p>Step 3g. $\psi_{cp,N} = 1.0$</p>	<p>17.6.2.6.1</p> <p>Table 3</p>
<p>Step 3h. Calculate $N_{cbg} = (47,600/32,400) \times 1 \times 0.97 \times 1 \times 19,246 = 27.33$ kN</p>	<p>17.6.2.1 b)</p> <p>§4.1.1 Table 3</p>
<p>Step 4. Controlling strength: $\phi N_{cbg} = 0.65 \times 27.33 = 17.77$ kN $< \phi N_s = 43.5$ kN</p>	<p>17.5.3</p> <p>Table 3</p>
<p>Step 5. Calculate allowable stress design (30% dead load, 70% live load) $\alpha = 1.2 \times 0.3 + 1.6 \times 0.7 = 1.48 \rightarrow T_{allowable, ASD} = 17.77 / 1.48 = 12.01$ kN</p>	<p>Section 5.3</p> <p>§4.2</p>

FIGURE 5—EXAMPLE CALCULATION FOR TENSION CAPACITY (SI UNITS)



Calculation according to ACI 318-19 Chapter 17 and this report	ACI 318-19	Report Ref.
Step 1. Verify minimum spacing and edge distance according to Figure 4 – Tension	17.9	Figure 4
Step 2. Calculate steel strength of anchor in shear $V_{sg} = n V_{sa} = 14,838$ lbf Calculate steel capacity $\phi V_{sg} = 0.65 * 14,832 = 9,645$ lbf	17.7.1 and 17.5.3 a)	Table 3
Step 3. Calculate concrete breakout strength of anchor in shear $V_{cbg} = \frac{A_{vc}}{A_{vc0}} \times \psi_{ec,V} \times \psi_{ed,V} \times \psi_{c,V} \times V_b$	17.7.2.1 b)	§ 4.1.4 § 4.1.6
Step 3a. Check $3 c_{a1} = 3 \times 3.15 = 9.45$ in. $> s = 3.94$ in. s_a controls $1.5 c_{a1} = 1.5 \times 3.15 = 4.72$ in. $< h_a$ c_{a1} controls $1.5 c_{a1} < c_{a2}$ c_{a1} controls	17.7.2.2	-
Step 3b. Calculate A_{vc0} and A_{vc} $A_{vc} = 4.5 \times c_1^2 = 4.5 \times (3.15)^2 = 44.65$ in. ² $A_{vc0} = (1.5 c_{a1}) \times (3 c_{a1} + s) = [1.5 \times 3.15] \times [3 \times (3.15) + 3.94] = 63.27$ in. ² $< 2 \times A_{vc0}$	17.7.2.1 b)	-
Step 3c. Calculate $\psi_{ec,V} : e_v = 0 \Rightarrow \psi_{ec,V} = 1$	17.7.2.3.1	-
Step 3d. Calculate $V_b = 7 \sqrt{f'_c} \times \sqrt{d_0} \times c_{a1}^{1.5} \times \left(\frac{le}{d_0}\right)^{0.2} = 7 \sqrt{5,076} \times \sqrt{0.47} \times 3.15^{1.5} \times \left(\frac{0.94}{0.47}\right)^{0.2} = 2,196$ lbf	17.7.2.2	-
Step 3e. Calculate modification factor for edge distance: $c_{a2} = 7.87 \geq 1.5 \times c_{a1} = 7.2$ $\psi_{ed,V} = 1$	17.7.2.4.1	-
Step 3f. $\psi_{c,V} = 1.0$ (cracked concrete)	17.7.2.5.1	-
Step 3g. Calculate $V_{cbg} = (63.27/44.65) \times 1 \times 1 \times 2,196 = 3,112$ lbf	17.7.2.1 b)	-
Step 3h. Calculate $\phi V_{cbg} = 3,112$ lbf $\times 0.7 = 2,178$ lbf	17.5.3	Table 3
Step 4. Calculate Pryout: $\phi V_{cpg} = k_{cp} \times \phi N_{cbg} = 1 \times 0.7 \times 6,264 = 4,385$ lbf N_{cbg} According to Figure 4 – Tension ($c_{a2} > 1.5 h_{ef}$)	17.7.3.1b)	Table 3
Step 5. Controlling strength: $\phi V_n = \min \{ \phi V_{cpg}, \phi V_{cbg}, \phi V_{sg} \} = 2,178$ lbf (static)	17.5.2	-
Step 6. Calculate allowable stress design (30% dead load, 70% live load) $\alpha = 1.2 \times 0.3 + 1.6 \times 0.7 = 1.48 \rightarrow V_{allowable, ASD} = 2,178 / 1.48 = 1,471$ lbf	Section 5.3	§4.2

FIGURE 6—EXAMPLE CALCULATION FOR SHEAR CAPACITY (IMPERIAL UNITS)

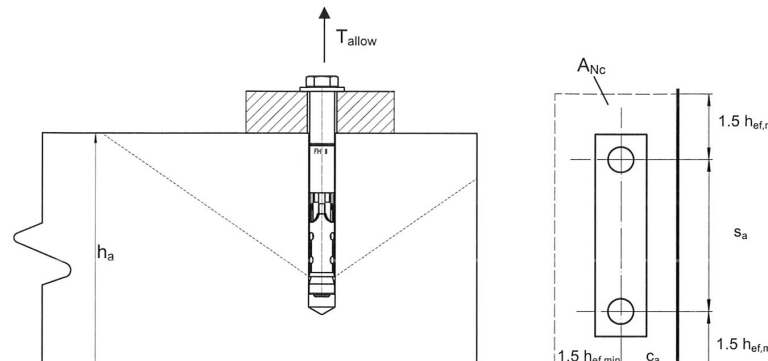
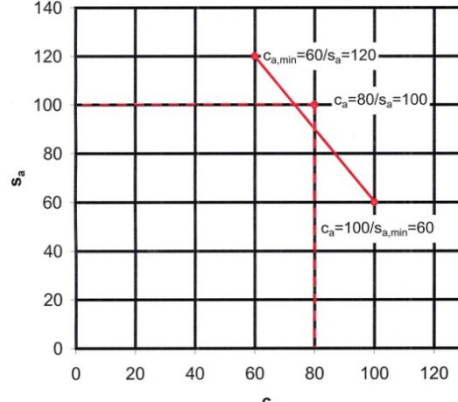
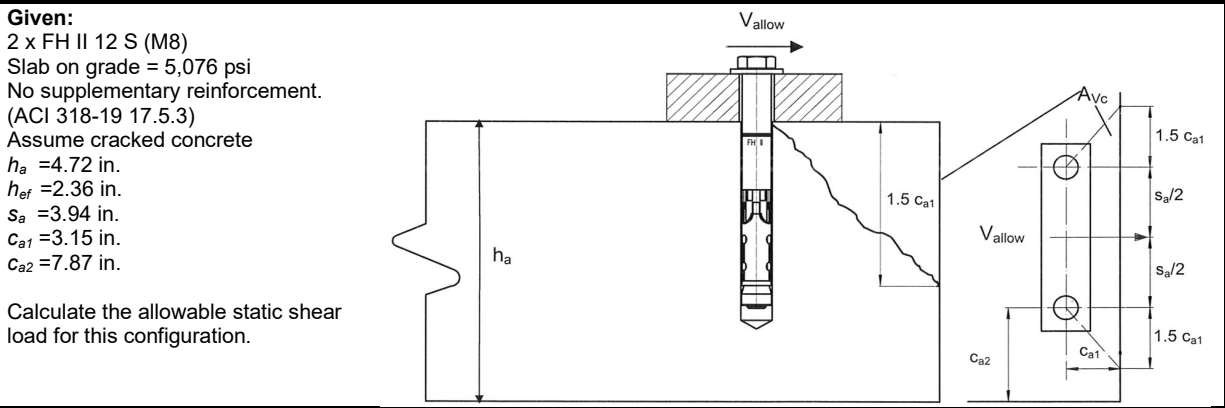
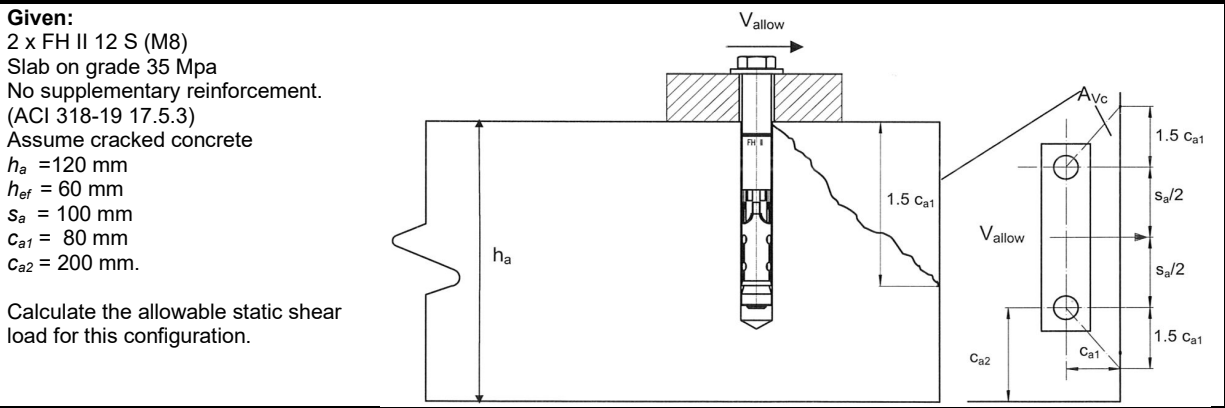

Calculation according to ACI 318-19 Chapter 17 and this report	ACI 318-19	Report Ref.
Step 1. Verify minimum spacing and edge distance according to Figure 5 – Tension	17.9 / D.8	Figure 5
Step 2. Calculate steel strength of anchor in shear $V_{sg} = n V_{sa} = 66$ kN Calculate steel capacity $\phi V_{sg} = 0.65 * 68 = 42.9$ kN	17.7.1 and 17.7.3 a)	Table 3
Step 3. Calculate concrete breakout strength of anchor in shear $V_{cbg} = \frac{A_{Vc}}{A_{Vc0}} \times \psi_{ec,V} \times \psi_{ed,V} \times \psi_{c,V} \times V_b$	17.7.2.1 b)	§ 4.1.4 § 4.1.6
Step 3a. Check $3 c_{a1} = 3 \times 80 = 240$ mm > $s = 100$ mm s controls $1.5 c_{a1} = 1.5 \times 80 = 120$ mm < h_a c_{a1} controls $1.5 c_{a1} < c_{a2}$ c_{a1} controls	17.7.2.2	-
Step 3b. Calculate A_{Vc0} and A_{Vc} $A_{Vc} = 4.5 \times c_1^2 = 4.5 \times (80)^2 = 28,800$ mm ² $A_{Vc0} = (1.5 c_{a1}) \times (3 c_{a1} + s) = [1.5 \times 80] \times [3 \times (80) + 100] = 40,800$ mm ² < $2 \times A_{Vc0}$	17.7.2.1 b)	-
Step 3c. Calculate $\psi_{ec,V} : e_v = 0 \Rightarrow \psi_{ec,V} = 1$	17.7.2.3.1	-
Step 3d. Calculate $V_b = 0.6 \sqrt{f'_c} \times \sqrt{d_0} \times c_{a1}^{1.5} \times \left(\frac{l_e}{d_0}\right)^{0.2} = 0.6 \times \sqrt{35} \times \sqrt{12} \times 80^{1.5} \times \left(\frac{24}{12}\right)^{0.2} = 10.11$ kN	17.7.2.2	-
Step 3e. Calculate modification factor for edge distance: $c_{a2} = 200 \geq 1.5 \times c_{a1} = 120$ $\psi_{ed,V} = 1$	17.7.2.4.1	-
Step 3f. $\psi_{c,V} = 1.0$ (cracked concrete)	17.7.2.5.1	-
Step 3g. Calculate $V_{cbg} = (40,800/28,800) \times 1 \times 1 \times 10.11 = 14.32$ kN	17.7.2.1 b)	-
Step 3h. Calculate $\phi V_{cbg} = 14.32$ kN $\times 0.7 = 10.02$ kN	17.5.3 c)	Table 3
Step 4. Calculate Pryout: $\phi V_{cp} = k_{cp} \times \phi N_{cbg} = 1 \times 0.7 \times 27.33 = 19.13$ kN N_{cbg} According to Figure 5 – Tension ($c_{a2} > 1.5 h_{ef}$)	17.7.3.1b)	Table 3
Step 5. Controlling strength: $\phi V_n = \min \{ \phi V_{cp}, \phi V_{cbg}, \phi V_{sg} \} = 10.02$ kN (static)	17.5.2	-
Step 6. Calculate allowable stress design (30% dead load, 70% live load) $\alpha = 1.2 \times 0.3 + 1.6 \times 0.7 = 1.48 \rightarrow V_{allowable, ASD} = 10.02 / 1.48 = 6.77$ kN	Section 5.3	§4.2

FIGURE 7—EXAMPLE CALCULATION SHEAR CAPACITY (SI UNITS)

DIVISION: 03 00 00—CONCRETE
Section: 03 16 00—Concrete Anchors

DIVISION: 05 00 00—METALS
Section: 05 05 19—Post-installed Concrete Anchors

REPORT HOLDER:

fischerwerke GmbH & CO. KG

EVALUATION SUBJECT:

fischer FH II CARBON STEEL HEAVY DUTY SLEEVE ANCHOR FOR ANCHORING IN CRACKED AND UNCRACKED CONCRETE

1.0 REPORT PURPOSE AND SCOPE

Purpose:

The purpose of this evaluation report supplement is to indicate that the fischer FH II Carbon Steel Heavy Duty Sleeve Anchors, described in ICC-ES evaluation report ESR-2691, have also been evaluated for compliance with the codes noted below.

Applicable code editions:

- 2022 and 2019 *California Building Code (CBC)*

For evaluation of applicable chapters adopted by the California Office of Statewide Health Planning and Development (OSHPD) AKA: California Department of Health Care Access and Information (HCAI) and the Division of State Architect (DSA), see Sections 2.1.1 and 2.1.2 below.

- 2022 and 2019 *California Residential Code (CRC)*

2.0 CONCLUSIONS

2.1 CBC:

The fischer FH II Carbon Steel Heavy Duty Sleeve Anchors, described in Sections 2.0 through 7.0 of the evaluation report ESR-2691, comply with CBC Chapter 19, provided the design and installation are in accordance with the 2021 and 2018 *International Building Code*® (IBC) provisions noted in the evaluation report and the additional requirements of CBC Chapters 16 and 17.

2.1.1 OSHPD:

The applicable OSHPD Sections and Chapters of the CBC are beyond the scope of this supplement.

2.1.2 DSA:

The applicable DSA Sections and Chapters of the CBC are beyond the scope of this supplement.

2.2 CRC:

The fischer FH II Carbon Steel Heavy Duty Sleeve Anchors, described in Sections 2.0 through 7.0 of the evaluation report ESR-2691, comply with CRC Section R301.1.3, provided the design and installation are in accordance with the 2021 and 2018 *International Building Code*® (IBC) provisions noted in the evaluation report and the additional requirements of CBC Chapters 16 and 17.

This supplement expires concurrently with the evaluation report, reissued April 2025.