



ETA-Danmark A/S
Göteborg Plads 1
DK-2150 Nordhavn
Tel. +45 72 24 59 00
Internet www.etadanmark.dk

Authorised and notified according
to Article 29 of the Regulation (EU)
No 305/2011 of the European
Parliament and of the Council of 9
March 2011

MEMBER OF EOTA



European Technical Assessment ETA-21/1062 of 2021/12/13

I General Part

Technical Assessment Body issuing the ETA and designated according to Article 29 of the Regulation (EU) No 305/2011: ETA-Danmark A/S

Trade name of the construction product:

fischer FCFcl Cavity Clad

Product family to which the above construction product belongs:

Fire Stopping and Sealing Product:
• Linear Joint and Gap Seals

Manufacturer:

fischerwerke GmbH & Co. KG
Klaus-fischer-Straße 1
72178 Waldachtal
Germany

Manufacturing plant:

fischerwerke GmbH & Co. KG

This European Technical Assessment contains:

9 pages including 2 annexes which form an integral part of the document

This European Technical Assessment is issued in accordance with Regulation (EU) No 305/2011, on the basis of:

EAD 350141-00-1106 Linear Joint and Gap Seals.

This version replaces:

-

Translations of this European Technical Assessment in other languages shall fully correspond to the original issued document and should be identified as such.

Communication of this European Technical Assessment, including transmission by electronic means, shall be in full [except the confidential Annex(es) referred to above]. However, partial reproduction may be made with the written consent of the issuing Technical Assessment Body. Any partial reproduction has to be identified as such.

I. SPECIFIC PARTS OF THE EUROPEAN TECHNICAL ASSESSMENT

1 Technical description of the product

- 1) fischer FCFcl Cavity Clad is a stone wool, mineral fibre board, foil faced on one side which is used to form a linear joint seal system. The intended use of fischer FCFcl Cavity Clad is to reinstate the fire resistance performance of floor to floor/ floor to wall joints, head of wall joints and wall gaps.
- 2) The fischer FCFcl Cavity Clad board is friction/compression fitted into the gap/joint and depending on gap width may also be retained by steel angles. Installation of the fischer FCFcl Cavity Clad system shall be in accordance with fischerwerke installation instructions.
- 3) fischerwerke submitted a written declaration that fischer FCFcl Cavity Clad does not contain substances which have to be classified as dangerous according to Directive 67/548/EEC and Regulation (EC) No 1272/2008 and listed in the "Indicative list on dangerous substances" of the EGDS - taking into account the installation conditions of the construction product and the release scenarios resulting from there.

In addition to the specific clauses relating to dangerous substances contained in this European technical Assessment, there may be other requirements applicable to the products falling within its scope (e.g. transposed European legislation and national laws, regulations and administrative provisions). In order to meet the provisions of the Construction Products Regulation, these requirements need also to be complied with, when and where they apply.

- 4) The use category of fischer FCFcl Cavity Clad in relation to BWR 3 (Hygiene, health and environment) is IA1, S/W3

2 Specification of the intended uses of the product in accordance with the applicable European Assessment Document (Hereinafter EAD)

Detailed information and data is given in Annex A.

- 1) The intended use of fischer FCFcl Cavity Clad is to reinstate the fire resistance performance of gaps in and joints between rigid floors and between rigid floors and rigid wall constructions, head of wall joints and gaps in rigid wall constructions.
- 2) The specific elements of construction that the system fischer FCFcl Cavity Clad may be used to provide a linear joint or gap seal in, are as follows:
 - a. Rigid floors: The floor must have a minimum thickness of 150 mm and comprise aerated concrete or concrete with a minimum density of 650 kg/m³.
 - b. Rigid walls: The wall must have a minimum thickness of 150 mm and comprise concrete, aerated concrete or masonry, with a minimum density of 650 kg/m³.

The supporting construction must be classified in accordance with EN 13501-2 for the required fire resistance period. (for details see Annex A)

- 3) The system fischer FCFcl Cavity Clad may be used to provide a linear joint or gap seal with specific supporting constructions and substrates (for details see Annex A).
- 4) The maximum permitted joint/gap width for system fischer FCFcl Cavity Clad is 150 mm.
- 5) The maximum movement capability of system fischer FCFcl Cavity Clad is $\leq 7.5\%$
- 6) The provisions made in this European Technical Assessment are based on an assumed working life of the fischer FCFcl Cavity Clad of 10 years, provided that the conditions laid down in the product datasheet for the packaging/transport/ storage/installation/use/repair are met. The indications given on the working life cannot be interpreted as a guarantee given by the producer or the Technical Assessment Body, but are to be regarded only as a means for choosing the right products in relation to the expected economically reasonable working life of the works.
- 7) Type Z₂: Intended for uses in internal conditions with humidity lower than 85 % RH excluding temperatures below 0°C, without exposure to rain or UV.

3 Performance of the product and references to the methods used for its assessment

Product-type: Stone, mineral wool board	Intended use: Linear Joint & Gap Seal
Essential characteristic	Performance
Mechanical resistance and stability	
None	Not relevant
Safety in case of fire	
Reaction to fire	No performance assessed
Resistance to fire	Annex A
Hygiene, health and environment	
Air permeability (material property)	Annex B
Water permeability (material property)	No performance assessed
Release of dangerous substances	Declaration of manufacturer
Safety in use	
Mechanical resistance and stability	No performance assessed
Resistance to impact/movement	No performance assessed
Adhesion	No performance assessed
Protection against noise	
Airborne sound insulation	$D_{ne,w} = 31\text{dB}$
Impact sound insulation	No performance assessed
Energy economy and heat retention	
Thermal properties	No performance assessed
Water vapour permeability	No performance assessed
General aspects relating to fitness for use	
Durability and serviceability	Y ₂

4 ASSESSMENT AND VERIFICATION OF CONSTANCY OF PERFORMANCE (HEREINAFTER AVCP) SYSTEM APPLIED, WITH REFERENCE TO ITS LEGAL BASE

According to the decision 1999/454/EC – Commission Decision of date 22nd June 1999 on the procedure for attesting the conformity of construction products pursuant to Article 20(2) of Council Directive 89/106/EEC as regards fire stopping, fire sealing and fire protective products, published in the Official Journal of the European Union (OJEU) L178/52 of 14/07/1999, see <http://eur-lex.europa.eu/JOIndex.do> of the European Commission¹, as amended, the system(s) of assessment and verification of constancy of performance (see Annex V to Regulation (EU) No 305/2011) given in the following table(s) applies (apply).

Product(s)	Intended use(s)	Level(s) or class(es)	System(s)
Fire stopping and Fire Sealing Products	For fire compartmentation and/or fire protection or fire performance	Any	1

5 Technical details necessary for the implementation of the AVCP system, as provided for in the applicable EAD

Technical details necessary for the implementation of the AVCP system are laid down in the control plan deposited at ETA-Danmark A/S prior to CE marking

Issued in Copenhagen on 2021-12-13 by



Thomas Bruun

Managing Director, ETA-Danmark

¹ Official Journal of the European Communities L178/52 of 14/7/1999

ANNEX A – Resistance to Fire Classification – fischer FCFcl Cavity Clad

A.1 Rigid floor constructions with thickness of minimum 150 mm

A.1.1 Linear joint or gap seal, between floor slabs or between floor slab and wall

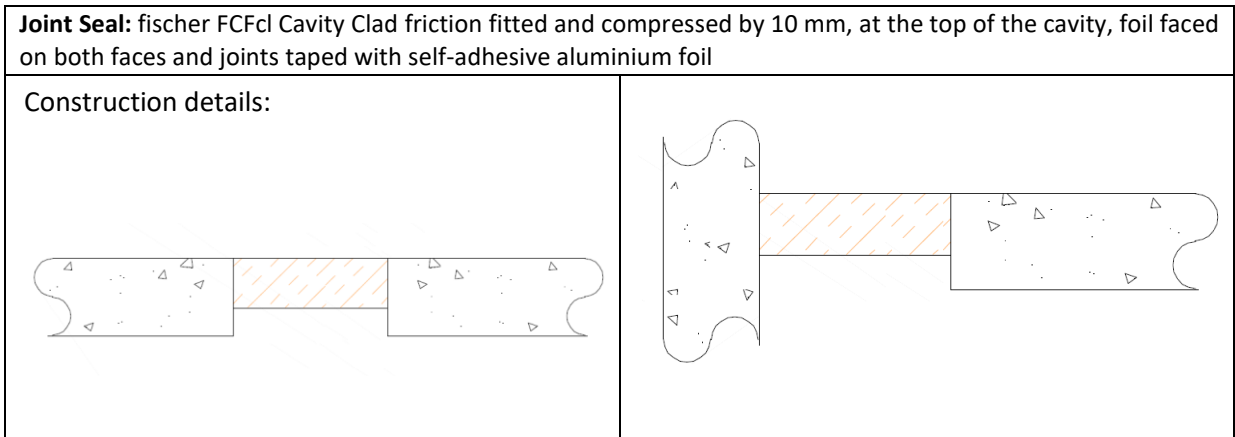

A.1.1.1

Substrate	Depth (mm)	Joints	Classification
masonry/ concrete	100 mm	100 mm wide Aluminium tape to both faces	E 120 – H – X – F – W00-150 EI 60 – H – X – F – W00-150
masonry/ concrete/ timber*	75 mm	100 mm wide Aluminium tape to top face	E 45 – H – X – F – W00-110 EI 30 – H – X – F – W00-110
masonry/ concrete/ timber [§]	100 mm		

* to one face only

[§] additionally, each section of board supported by a single 'Z' shaped steel hangar (1 x 25 x 400 mm) bent to span the full width of the seal (inserted at mid-depth) and rested upon the top of the floor slab

A.2 Rigid wall constructions with thickness of minimum 150 mm

A.2.1 Linear joint or gap seal, at head of walls and in walls

Joint Seal: fischer FCFcl Cavity Clad friction fitted and compressed by 10 mm, at any depth within the wall, foil faced on both faces and joints taped with self-adhesive aluminium foil

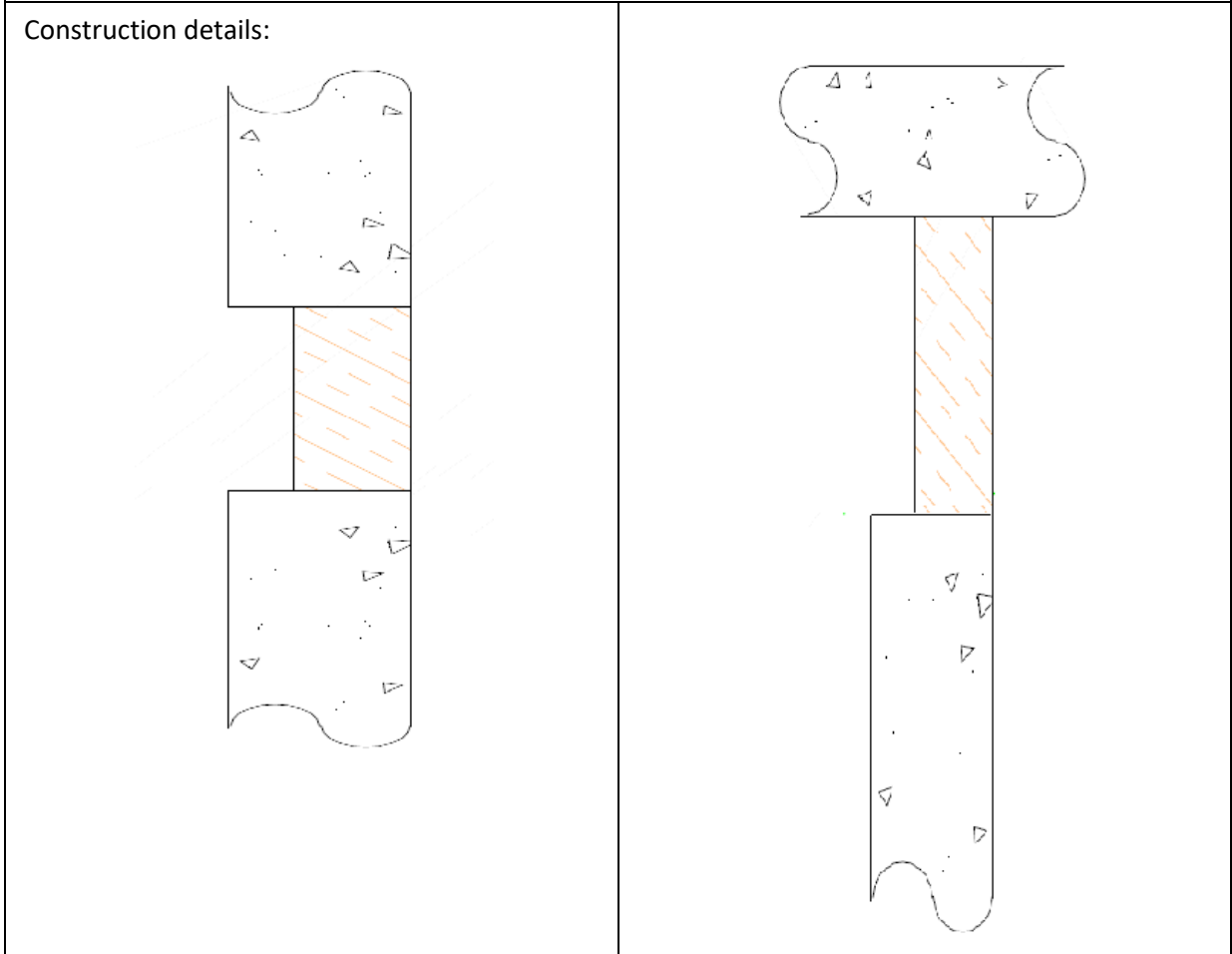

A.2.1.1

Substrate	Depth (mm)	Joints	Classification
masonry/ concrete	100 mm	100 mm wide Aluminium tape to both faces	E 30 – T – X – F – W00-110 EI 15 – T – X – F – W00-110
	75 mm	100 mm wide Aluminium tape to top face	EI 30 – T – X – F – W00-110

ANNEX B – Air Permeability Performance – fischer FCFcl Cavity Clad

B.1 fischer FCFcl Cavity Clad board 100 mm thick, joints taped on both faces (per metre length of seal)

Pressure (Pa)	Leakage under positive pressure $\text{m}^3\text{h}^{-1}\text{m}^{-1}$	Leakage under negative pressure $\text{m}^3\text{h}^{-1}\text{m}^{-1}$
50	2.42	1.92
100	1.58	2.5
150	1.75	2.5
200	2	2.58
250	1.83	1.92
300	2.08	1.92
450	2.42	1.08
600	3.33	0.33