

Approval body for construction products  
and types of construction

Bautechnisches Prüfamt

An institution established by the Federal and  
Laender Governments



## European Technical Assessment

**ETA-17/0351**  
**of 1 March 2022**

English translation prepared by DIBt - Original version in German language

### General Part

Technical Assessment Body issuing the  
European Technical Assessment:

Deutsches Institut für Bautechnik

Trade name of the construction product

Rebar connection with injection system FIS AB

Product family  
to which the construction product belongs

System for post installed  
rebarconnection with mortar

Manufacturer

fischerwerke GmbH & Co. KG  
Klaus-Fischer-Straße 1  
72178 Waldachtal  
DEUTSCHLAND

Manufacturing plant

fischerwerke

This European Technical Assessment  
contains

20 pages including 3 annexes which form an integral part  
of this assessment

This European Technical Assessment is  
issued in accordance with Regulation (EU)  
No 305/2011, on the basis of

EAD 330087-01-0601, Edition 06/2021

This version replaces

ETA-17/0351 issued on 28 August 2017

The European Technical Assessment is issued by the Technical Assessment Body in its official language. Translations of this European Technical Assessment in other languages shall fully correspond to the original issued document and shall be identified as such.

Communication of this European Technical Assessment, including transmission by electronic means, shall be in full. However, partial reproduction may only be made with the written consent of the issuing Technical Assessment Body. Any partial reproduction shall be identified as such.

This European Technical Assessment may be withdrawn by the issuing Technical Assessment Body, in particular pursuant to information by the Commission in accordance with Article 25(3) of Regulation (EU) No 305/2011.

## Specific Part

### 1 Technical description of the product

The subject of this European Technical Assessment is the post-installed connection, by anchoring or overlap connection joint, of reinforcing bars (rebars) in existing structures made of normal weight concrete, using the " Rebar connection with injection system FIS AB" in accordance with the regulations for reinforced concrete construction.

Reinforcing bars with a diameter  $\phi$  from 10 to 25 mm Annex A and the fischer injection mortar FIS AB are used for the post-installed rebar connection. The steel element is placed into a drilled hole filled with injection mortar and is anchored via the bond between embedded reinforcing bar, injection mortar and concrete.

The product description is given in Annex A.

### 2 Specification of the intended use in accordance with the applicable European assessment Document

The performances given in Section 3 are only valid if the rebar connection is used in compliance with the specifications and conditions given in Annex B.

The verifications and assessment methods on which this European Technical Assessment is based lead to the assumption of a working life of the rebar connection of at least 50 years. The indications given on the working life cannot be interpreted as a guarantee given by the producer, but are to be regarded only as a means for choosing the right products in relation to the expected economically reasonable working life of the works.

### 3 Performance of the product and references to the methods used for its assessment

#### 3.1 Mechanical resistance and stability (BWR 1)

Essential characteristic	Performance
Characteristic resistance under static and quasi-static loading	See Annex C 1
Characteristic resistance under seismic action	No performance assessed

#### 3.2 Safety in case of fire (BWR 2)

Essential characteristic	Performance
Reaction to fire	Class A1
Resistance to fire	See Annex C 2

### 4 Assessment and verification of constancy of performance (AVCP) system applied, with reference to its legal base

In accordance with European Assessment Document EAD No. 330087-01-0601, the applicable European legal act is: [96/582/EC].

The system(s) to be applied is (are): 1

**5 Technical details necessary for the implementation of the AVCP system, as provided for in the applicable European Assessment Document**

Technical details necessary for the implementation of the AVCP system are laid down in the control plan deposited with Deutsches Institut für Bautechnik.

Issued in Berlin on 1. March 2022 by Deutsches Institut für Bautechnik

Dipl.-Ing. Beatrix Wittstock  
Head of Section

Beglaubigt  
Baderschneider

## Installation conditions and application examples reinforcing bars, part 1

**Figure A1.1:**

Overlap joint with existing reinforcement for rebar connections of slabs and beams

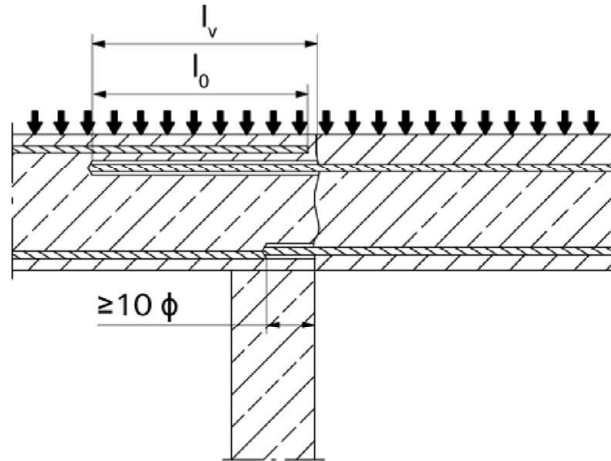

**Figure A1.2:**

Overlap joint with existing reinforcement at a foundation of a column or wall where the rebar is stressed

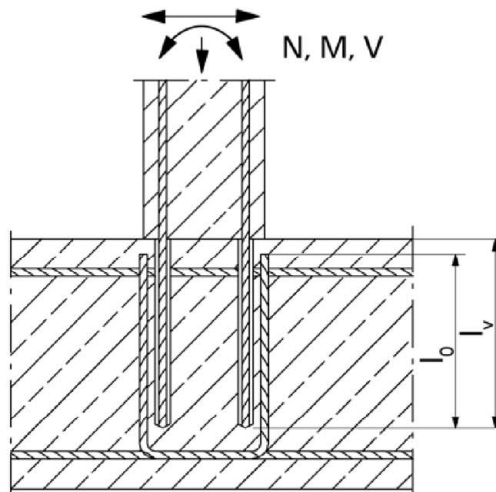

**Figure A1.3:**

End anchoring of slabs or beams (e.g. designed as simply supported)

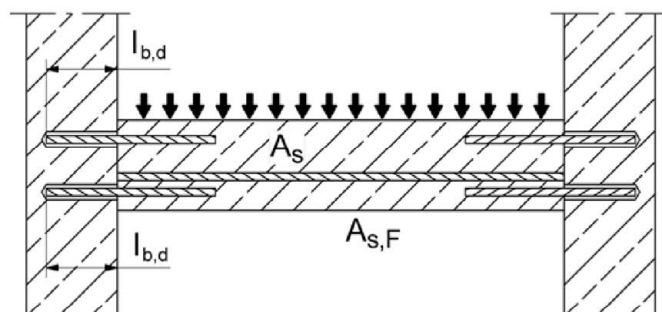

Figures not to scale

Rebar connection with injection system FIS AB

**Product description**

Installation conditions and application examples reinforcing bars, part 1

**Annex A 1**

## Installation conditions and application examples reinforcing bars, part 2

**Figure A2.1:**

Rebar connection for stressed primarily in compression

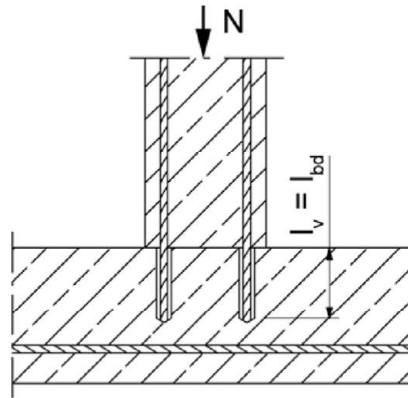

**Figure A2.2:**

Anchoring of reinforcement to cover the enveloped line of acting tensile force in the bending member

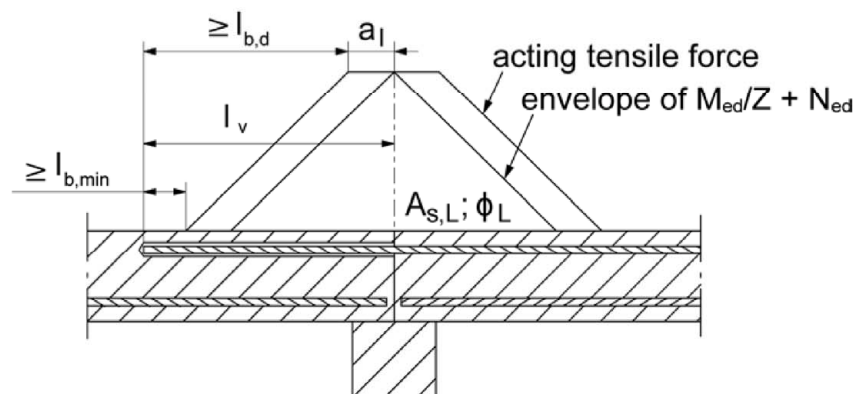

Note to **figure A1.1 to A1.3** and **figure A2.1 to A2.2**

In the figures no traverse reinforcement is plotted, the transverse reinforcement shall comply with EN 1992-1-1: 2004+AC:2010.

Preparing of joints according to **Annex B 2**

Figures not to scale

Rebar connection with injection system FIS AB

**Product description**

Installation conditions and application examples reinforcing bars, part 2

**Annex A 2**

## Overview system components

**Injection cartridge (shuttle cartridge) FIS AB with sealing cap; Sizes: 360 ml, 825 ml**

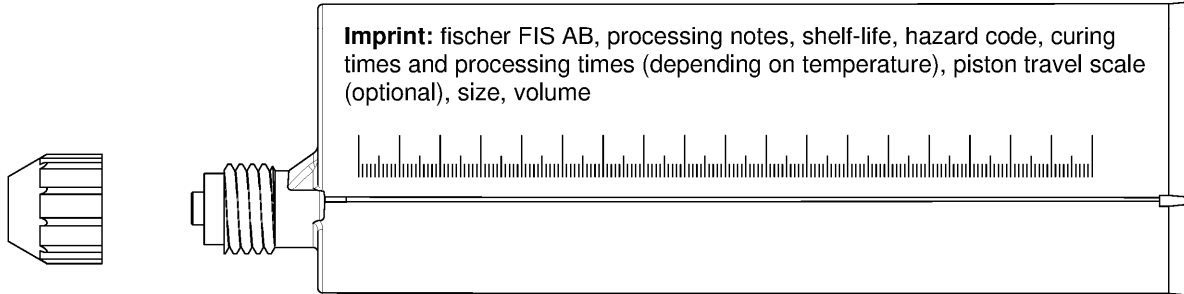

**Injection cartridge (coaxial cartridge) FIS AB with sealing cap; Sizes: 300 ml, 380 ml, 400 ml, 410 ml**

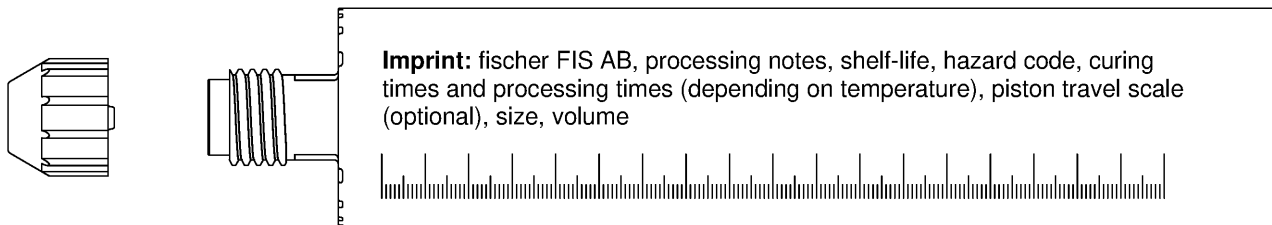

**Static mixer FIS MR Plus for injection cartridges up to 410 ml**

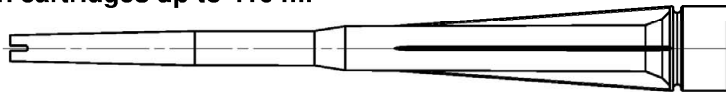

**Static mixer FIS JMR for injection cartridges 825 ml**

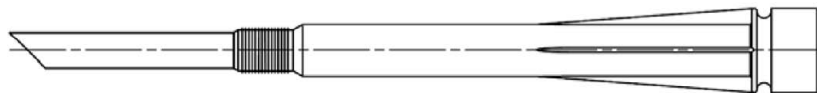

**Injection adapter and extension tube Ø 9 for static mixer FIS MR Plus;  
Injection adapter and extension tube Ø 9 or Ø 15 for static mixer FIS JMR**



**Reinforcing bar (rebar) Sizes:  $\phi 10$ ,  $\phi 12$ ,  $\phi 14$ ,  $\phi 16$ ,  $\phi 20$ ,  $\phi 25$**



**Compressed-air cleaning tool with compressed-air nozzle:**

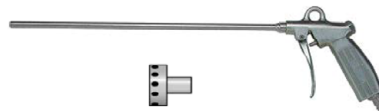

Figures not to scale

Rebar connection with injection system FIS AB

**Product description**

Overview system components; Injection mortar, static mixer, injection adapter, reinforcing bar, blow out pump

**Annex A 3**

## Properties of reinforcing bars (rebar)

Figure A4.1:



- The minimum value of related rip area  $f_{R,min}$  according to EN 1992-1-1:2004+AC:2010
- The maximum outer rebar diameter over the ribs shall be:
  - The nominal diameter of the rip  $\phi + 2 * h$  ( $h \leq 0,07 * \phi$ )
  - ( $\phi$ : Nominal diameter of the bar;  $h_{rib}$  = height of the bar)

Table A4.1: Installation conditions for rebars

Nominal diameter of the bar		$\phi$	10 <sup>1)</sup>		12 <sup>1)</sup>		14	16	20	25 <sup>1)</sup>	
Nominal drill hole diameter	$d_0$	[mm]	12	14	14	16	18	20	25	30	35
Drill hole depth	$h_0$		$h_0 = l_v$								
Effective embedment depth	$l_v$		acc. to static calculation								
Minimum thickness of concrete member	$h_{min}$		$l_v + 30$ ( $\geq 100$ )			$l_v + 2d_0$					

<sup>1)</sup> Both drill hole diameters can be used

Table A4.2: Materials of rebars

Designation	Reinforcing bar (rebar)
Reinforcing bar EN 1992-1-1:2004+AC:2010, Annex C	Bars and de-coiled rods class B or C with $f_{yk}$ and $k$ according to NDP or NCI of EN 1992-1-1/NA $f_{uk} = f_{tk} = k \cdot f_{yk}$



Figures not to scale

Rebar connection with injection system FIS AB

**Product description**  
Properties and materials of reinforcing bars (rebar)

**Annex A 4**



Specifications of intended use part 1		
Table B1.1: Overview use and performance categories		
Anchorage subject to	<b>FIS AB with ...</b>	
	Reinforcing bar 	
Hammer drilling with standard drill bit 	all sizes	
Hammer drilling with hollow drill bit (fischer "FHD", Heller "Duster Expert", Bosch "Speed Clean", Hilti "TE-CD, TE-YD") 	Nominal drill bit diameter ( $d_0$ ) 12 mm to 35 mm	
Static and quasi static load, in	uncracked concrete cracked concrete	all sizes Tables: C1.1 C1.2 C1.3
Installation temperature	$T_{i,min} = 0\text{ °C}$ to $T_{i,max} = +40\text{ °C}$	
Resistance to fire	all sizes	Annex C2
Rebar connection with injection system FIS AB		<b>Annex B 1</b>
Intended use Specifications part 1		

## Specifications of intended use part 2

### Anchorage subject to:

- Static and quasi-static loads: reinforcing bar (rebar) size 10 mm to 25 mm
- Fire exposure

### Base materials:

- Compacted reinforced or unreinforced normal weight concrete without fibres according to EN 206:2013+A1:2016
- Concrete strength classes C20/25 to C35/45 according to EN 206:2013+A1:2016
- Maximum chloride content of 0,40 % (CL 0.40) related to the cement content according to EN 206:2013+A1:2016
- Non-carbonated concrete

Note: In case of a carbonated surface of the existing concrete structure the carbonated layer shall be removed in the area of the post-installed rebar connection with a diameter of  $\phi + 60$  mm prior to the installation of the new rebar. The depth of concrete to be removed shall correspond to at least the minimum concrete cover in accordance with EN 1992-1-1 :2004+AC:2010. The foregoing may be neglected if building components are new and not carbonated and if building components are in dry conditions.

### Temperature Range:

- $-40^{\circ}\text{C}$  to  $+80^{\circ}\text{C}$  (max. short term temperature  $+80^{\circ}\text{C}$  and max long term temperature  $+50^{\circ}\text{C}$ ).

### Installation temperature:

- $0^{\circ}\text{C}$  to  $+40^{\circ}\text{C}$

### Design:

- Fastenings are designed under the responsibility of an engineer experienced in fastenings and concrete work.
- Verifiable calculation notes and drawings are prepared taking account of the forces to be transmitted.
- Design according to EN 1992-1-1:2004+AC:2010; EN 1992-1-2:2004+AC:2008 and Annex B 3.
- The actual position of the reinforcement in the existing structure shall be determined on the basis of the construction documentation and taken into account when designing.

### Installation:

- Dry or wet concrete
- Installation in water filled holes is not allowed
- Hole drilling by hammer drill, hollow drill or compressed air drill mode
- Overhead installation allowed
- The installation of post-installed rebar shall be done only by suitable trained installer and under Supervision on site; the conditions under which an installer may be considered as suitable trained and the conditions for Supervision on site are up to the Member States in which the installation is done.
- Check the position of the existing rebars (if the position of existing rebars is not known, it shall be determined using a rebar detector suitable for this purpose as well as on the basis of the construction documentation and then marked on the building component for the overlap joint).

Rebar connection with injection system FIS AB

**Intended use**  
Specifications part 2

**Annex B 2**

## General construction rules for post-installed rebars

**Figure B3.1:**

- Only tension forces in the axis of the rebar may be transmitted.
- The transfer of shear forces between new concrete and existing structure shall be designed additionally according to EN 1992-1-1:2004+AC:2010.
- The joints for concreting must be roughened to at least such an extent that aggregate protrude.

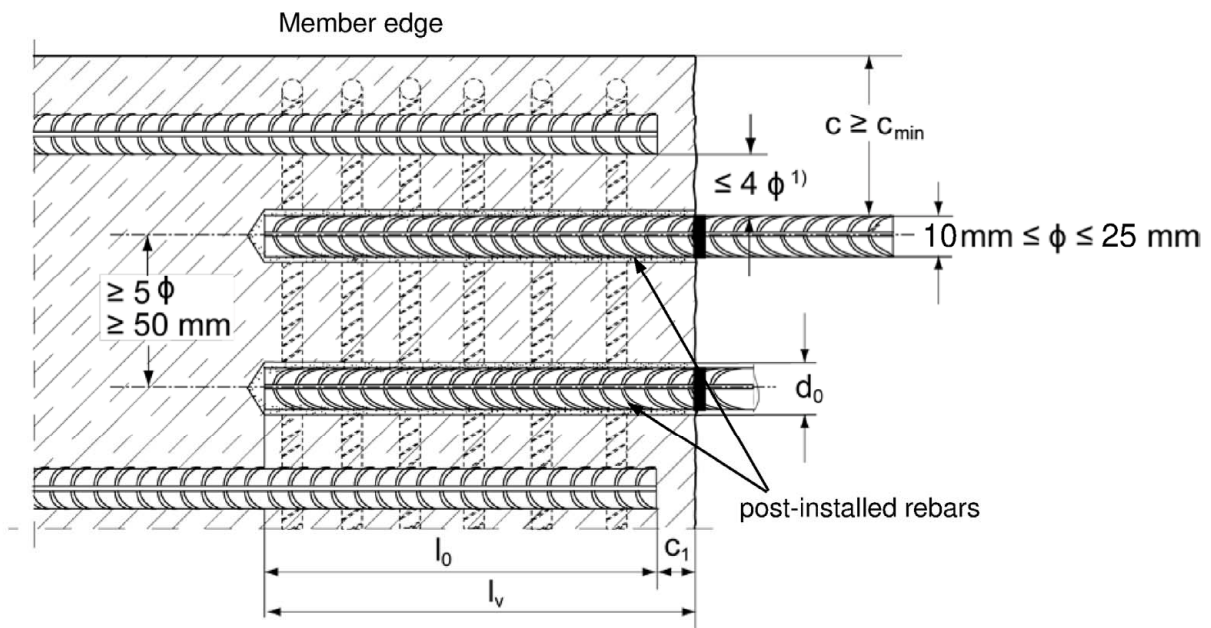

<sup>1)</sup> If the clear distance between lapped bars exceeds  $4 \phi$  then the lap length shall be increased by the difference between the clear bar distance and  $4 \phi$

- c concrete cover of post-installed rebar  
 $c_1$  concrete cover at end-face of existing rebar  
 $c_{min}$  minimum concrete cover according to table B5.1 and to EN 1992-1-1:2004+AC:2010, Section 4.4.1.2  
 $\phi$  nominal diameter of reinforcing bar  
 $l_0$  lap length, according to EN 1992-1-1:2004+AC:2010  
 $l_v$  effective embedment depth,  $\geq l_0 + c_1$   
 $d_0$  nominal drill bit diameter, see Annex B 5

Figures not to scale

Rebar connection with injection system FIS AB

**Intended use**  
General construction rules for post-installed rebars

**Annex B 3**

**Table B4.1: Minimum concrete cover  $c_{min}^{1)}$  depending of the drilling method and the drilling tolerance**

Drilling method	nominal diameter of reinforcing bar $\phi$ [mm]	Minimum concrete cover $c_{min}$	
		Without drilling aid [mm]	With drilling aid [mm]
Hammer drilling with standard drill bit	< 25	30 mm + 0,06 $l_v \geq 2 \phi$	30 mm + 0,02 $l_v \geq 2 \phi$
	= 25	40 mm + 0,06 $l_v \geq 2 \phi$	40 mm + 0,02 $l_v \geq 2 \phi$
Hammer drilling with hollow drill bit (fischer "FHD", Heller "Duster Expert" Bosch "Speed Clean", Hilti "TE-CD, TE-YD")	< 25	30 mm + 0,06 $l_v \geq 2 \phi$	30 mm + 0,02 $l_v \geq 2 \phi$
	= 25	40 mm + 0,06 $l_v \geq 2 \phi$	40 mm + 0,02 $l_v \geq 2 \phi$
Compressed air drilling	< 25	50 mm + 0,08 $l_v$	50 mm + 0,02 $l_v$
	= 25	60 mm + 0,08 $l_v \geq 2 \phi$	60 mm + 0,02 $l_v \geq 2 \phi$

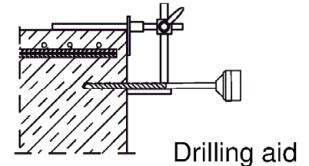

<sup>1)</sup> See Annex B3, figure B3.1

Note: The minimum concrete cover as specified in EN 1992-1-1:2004+AC:2010 must be observed.

**Table B4.2: Dispensers and cartridge sizes corresponding to maximum embedment depth  $l_{v,max}$**

reinforcing bars (rebar) $\phi$ [mm]	Manual dispenser	Accu and pneumatic dispenser (small)	Accu and pneumatic dispenser (large)
	Cartridge size		
	< 500 ml $l_{v,max} / l_{e,ges,max}$ [mm]		> 500 ml $l_{v,max} / l_{e,ges,max}$ [mm]
10	1000	1000	1800
12		1200	
14		1500	
16		1300	
20	700	1000	2000
25			

Figures not to scale

Rebar connection with injection system FIS AB

**Intended use**

Minimum concrete cover;  
dispenser and cartridge sizes corresponding to maximum embedment depth

**Annex B 4**

**Table B5.1:** Working times  $t_{work}$  and curing times  $t_{cure}$

Temperature in the anchorage base [°C]	Maximum working time <sup>1)</sup>	Minimum curing time <sup>2)</sup>
	$t_{work}$ <b>FIS AB</b>	$t_{cure}$ <b>FIS AB</b>
>±0 to +5	13 min <sup>3)</sup>	3 h
>+5 to +10	9 min <sup>3)</sup>	90 min
>+10 to +20	5 min	60 min
>+20 to +30	4 min	45 min
>+30 to +40	2 min <sup>4)</sup>	35 min

<sup>1)</sup> Maximum time from the beginning of the injection to rebar setting and positioning

<sup>2)</sup> For wet concrete the curing time must be doubled

<sup>3)</sup> If the temperature in the concrete falls below 10°C the cartridge has to be warmed up to +15°C.

<sup>4)</sup> If the temperature in the concrete exceeds 30 °C the cartridge has to be cooled down to +15°C up to 20°C

**Table B5.2:** Installation tools for drilling and cleaning the bore hole and injection of the mortar

reinforcing bars (rebar)  $\phi$ [mm]	Drilling and cleaning				Injection	
	Nominal drill bit diameter $d_0$ [mm]	Diameter of cutting edge $d_{cut}$ [mm]	Steel brush diameter $d_b$ [mm]	Diameter of cleaning nozzle [mm]	Diameter of extension tube [mm]	Injection adapter [colour]
10 <sup>1)</sup>	12	$\leq 12,50$	12,5	11	9	nature
	14	$\leq 14,50$	15			blue
12 <sup>1)</sup>	14	$\leq 14,50$	15	15	9 or 15	red
	16	$\leq 16,50$	17			yellow
14	18	$\leq 18,50$	19	19	9 or 15	green
16	20	$\leq 20,55$	21,5			black
20	25	$\leq 25,55$	26,5			grey
25 <sup>1)</sup>	30	$\leq 30,55$	32	28	9 or 15	brown
	35	$\leq 35,70$	37			

<sup>1)</sup> Both drill bit diameters can be used

Rebar connection with injection system FIS AB

**Intended use**

Working times and curing times;  
Installation tools for drilling and cleaning the bore hole and injection of the mortar

**Annex B 5**

## Safety regulations



Review the Safety Data Sheet (SDS) before use for proper and safe handling!  
Wear well-fitting protective goggles and protective gloves when working with mortar FIS AB.  
Important: Observe the instructions for use provided with each cartridge.

## Installation instruction part 1; Installation with FIS AB

### Hole drilling

Note: Before drilling, remove carbonized concrete; clean contact areas (see Annex B 2)  
In case of aborted drill holes the drill hole shall be filled with mortar.

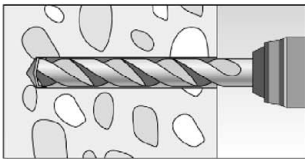
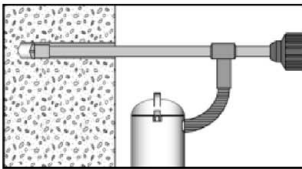
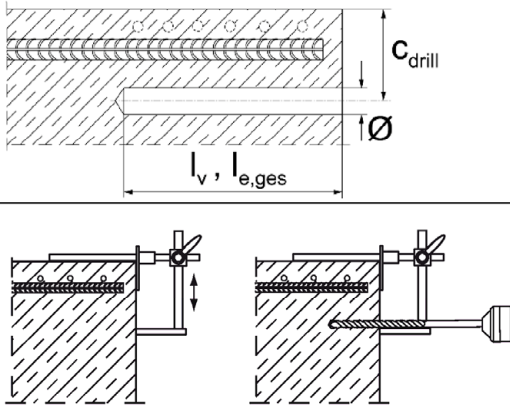
<p><b>1a</b></p>	<p><b>Hammer drilling or compressed air drilling</b></p> 	<p>Drill the hole to the required embedment depth using a hammer drill with carbide drill bit set in rotation hammer mode or a pneumatic drill. Drill bit sizes see table B5.2.</p>
<p><b>1b</b></p>	<p><b>Hammer drilling with hollow drill bit</b></p> 	<p>Drill the hole to the required embedment depth using a hammer drill with hollow drill bit in rotation hammer mode. Dust extraction conditions see drill hole cleaning annex B 7. Drill bit sizes see table B5.2.</p>
<p><b>2</b></p>		<p>Measure and control concrete cover <math>c</math> (<math>c_{\text{drill}} = c + \varnothing / 2</math>) Drill parallel to surface edge and to existing rebar. Where applicable use drilling aid.</p> <p>For holes <math>l_v &gt; 20</math> cm use drilling aid. Three different options can be considered: A) drilling aid B) Slat or spirit level C) Visual check</p> <p>Minimum concrete cover <math>c_{\text{min}}</math> see table B4.1</p>



Rebar connection with injection system FIS AB

**Intended use**  
Safety regulations; Installation instruction part 1, hole drilling

**Annex B 6**

## Installation instruction part 2; Installation with FIS AB

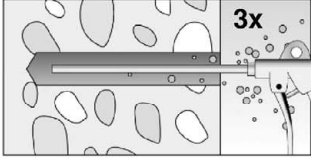
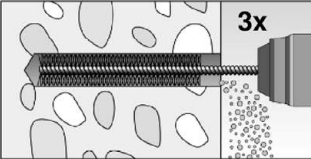
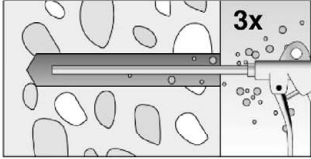
### Drill hole cleaning

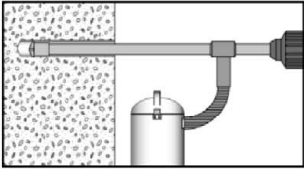
<p><b>3a</b></p>	<p><b>Hammer or compressed air drilling</b></p>	
		<p><b>Blowing</b> three times from the back of the hole with the appropriate nozzle (oil-free compressed air <math>\geq 6</math> bar) until return air stream is free of noticeable dust. Personal protective equipment must be used (see regulations Annex B 6).</p>
		<p><b>Brushing (with power drill)</b> three times with the suitable brush size (brush diameter &gt; drill hole diameter). Switch on the power drill after inserting the steel brush into the drill hole. The brush must produce a noticeable resistance when it is inserted into the drill hole. If this is not the case, use a new or larger brush. If necessary, check with brush inspection template. Suitable brushes see table B5.2.</p>
	<p><b>Blowing</b> three times from the back of the hole with the appropriate nozzle (oil-free compressed air <math>\geq 6</math> bar) until return air stream is free of noticeable dust. Personal protective equipment must be used. (see regulations Annex B 6).</p>	
<p><b>3b</b></p>	<p><b>Hammer drilling with hollow drill bit</b></p>	
		<p>Use a suitable dust extraction system, e. g. fischer FVC 35 M or a comparable dust extraction system with equivalent performance data. Drill the hole with hollow drill bit. The dust extraction system has to extract the drill dust nonstop during the drilling process and must be adjusted to maximum power. No further drill hole cleaning necessary</p>
<p>Rebar connection with injection system FIS AB</p>		<p><b>Annex B 7</b></p>
<p><b>Intended use</b> Installation instruction part 2, drill hole cleaning</p>		

### Installation instruction part 3; Installation with FIS AB

#### reinforcing bars (rebar) and cartridge preparation

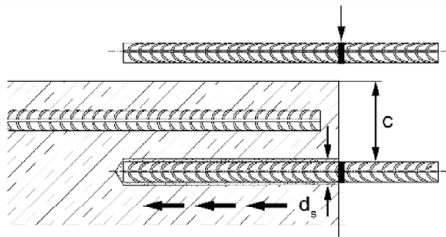
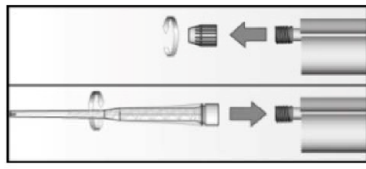
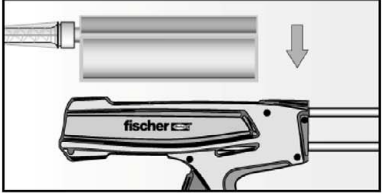
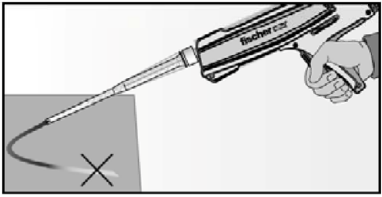
4		<p>Before use, make asure that the rebar is dry and free of oil or other residue. Mark the embedment depth <math>l_v</math> (e.g. with tape) Insert rebar in borehole, to verify drill hole depth and setting depth <math>l_v</math> resp. <math>l_{e,ges}</math></p>
5		<p>Twist off the sealing cap Twist on the static mixer (the spiral in the static mixer must be clearly visible).</p>
6		<p>Place the cartridge into a suitable dispenser.</p>
7		<p>Press out approximately 10 cm of mortar until the resin is permanently grey in colour. Mortar which is not grey in colour will not cure and must be disposed.</p>

Rebar connection with injection system FIS AB

**Intended use**

Installation instruction part 3, reinforcing bars (rebar) and cartridge preparation

**Annex B 8**



### Installation instruction part 4; Installation with FIS AB

#### Injection of the mortar; borehole depth ≤ 250 mm

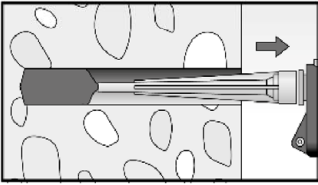
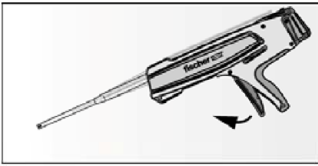
<b>8a</b>		<p>Inject the mortar from the back of the hole towards the front and slowly withdraw the static mixer step by step with each trigger pull. Avoid bubbles.</p> <p>Fill holes approximately 2/3 full, to ensure that the annular gap between the rebar and the concrete will be completely filled with adhesive over the entire embedment length.</p>
		<p>After injecting, release the dispenser. This will prevent further mortar discharge from the static mixer.</p>

#### Injection of the mortar; borehole depth > 250 mm

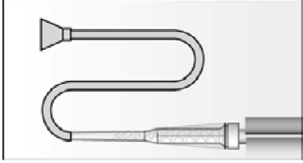
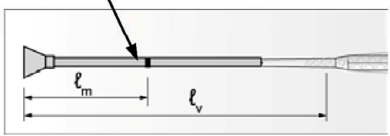
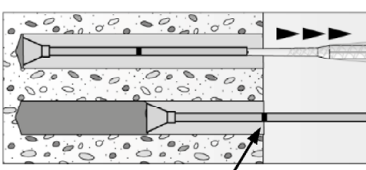
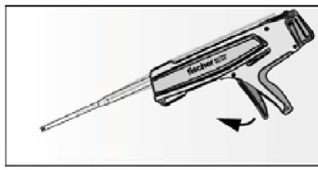
<b>8b</b>		<p>Assemble static mixer, extension tube and appropriate injection adapter (see table B5.2)</p>
	<p>Mortar level mark</p> 	<p>Mark the required mortar level <math>l_m</math> and embedment depth <math>l_v</math> resp. <math>l_{e,ges}</math> with tape or marker on the injection extension tube.</p> <p>a) Estimation:  <math display="block">l_m = \frac{1}{3} * l_v \text{ resp. } l_m = \frac{1}{3} * l_{e,ges} [\text{mm}]</math> </p> <p>b) Precise equation for optimum mortar volume:  <math display="block">l_m = l_v \text{ resp. } l_{e,ges} \left( \left( 1,2 * \frac{d_s^2}{d_0^2} - 0,2 \right) \right) [\text{mm}]</math> </p>
	<p>Mortar level mark</p> 	<p>Insert injection adapter to back of the hole. Begin injection allowing the pressure of the injected adhesive mortar to push the injection adapter towards the front of the hole. Do not actively pull out!</p> <p>Fill holes approximately 2/3 full, to ensure that the annular gap between the rebar and the concrete will be completely filled with adhesive over the embedment length.</p> <p>When using an injection adapter continue injection until the mortar level mark <math>l_m</math> becomes visible.</p> <p>Maximum embedment depth see table B4.2</p>
		<p>After injecting, release the dispenser. This will prevent further mortar discharge from the static mixer.</p>



Rebar connection with injection system FIS AB

**Intended use**  
Installation instruction part 4, mortar injection

**Annex B 9**

### Installation instruction part 5; Installation with FIS AB

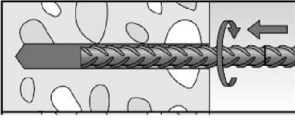
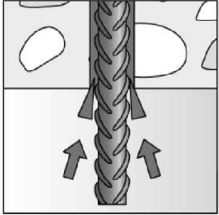
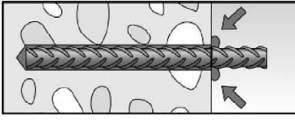
#### Insert rebar

9		<p>Insert the rebar slowly twisted into the borehole until the embedment mark is reached.</p>
10		<p>For overhead installation, support the rebar and secure it from falling till mortar started to harden, e.g. using wedges.</p>
11		<p>After installing the rebar the annular gap must be completely filled with mortar.</p> <p>Proper installation</p> <ul style="list-style-type: none"> <li>• Desired embedment depth is reached <math>l_v</math>: embedment mark at concrete surface</li> <li>• Excess mortar flows out of the borehole after the rebar has been fully inserted up to the embedment mark.</li> </ul>
12		<p>Observe the working time "<math>t_{work}</math>" (see table B5.1), which varies according to temperature of base material. Minor adjustments to the rebar position may be performed during the working time</p> <p>Full load may be applied only after the curing time "<math>t_{cure}</math>" has elapsed (see table B 5.1)</p>

Rebar connection with injection system FIS AB

**Intended use**  
Installation instruction part 5, insert rebar

**Annex B 10**

## Minimum anchorage length and minimum lap length

The minimum anchorage length  $l_{b,min}$  and the minimum lap length  $l_{0,min}$  according to EN 1992-1-1:2004+AC:2010 shall be multiply by the relevant amplification factor  $\alpha_{lb}$  according to table C1.1.

**Table C1.1:** Amplification factor  $\alpha_{lb}$  related to concrete strength class and drilling method

Concrete strength class	Drilling method	Amplification factor $\alpha_{lb}$
C20/25 to C35/45	Hammer drilling with standard drill bit	1,0
	Hammer drilling with hollow drill bit (fischer "FHD", Heller "Duster Expert", Bosch "Speed Clean"; Hilti "TE-CD, TE-YD")	1,0
	Compressed air drilling	1,0

**Table C1.2:** Bond efficiency factor  $k_b$  for hammer drilling, hollow drilling and compressed air drilling

Rebar $\phi$ [mm]	Bond efficiency factor $k_b$			
	Concrete strength class			
	C20/25	C25/30	C30/37	C35/45
10 to 25	1,00			

**Table C1.3:** Design values of the bond strength  $f_{bd,PIR}$  in N/mm<sup>2</sup> for hammer drilling, hollow drilling, compressed air drilling and for good bond conditions

$$f_{bd,PIR} = k_b \cdot f_{bd}$$

$f_{bd}$ : Design value of the bond strength in N/mm<sup>2</sup> considering the concrete strength classes and the rebar diameter for good bond condition (for all other bond conditions multiply the values by  $\eta_1 = 0,7$ ) and recommended partial factor  $\gamma_c = 1,5$  according to EN 1992-1-1: 2004+AC:2010

$k_b$ : Bond efficiency factor according to table C1.2

### Hammer drilling, hollow drilling and compressed air drilling

Rebar $\phi$ [mm]	bond strength $f_{bd,PIR}$ [N/mm <sup>2</sup> ]			
	Concrete strength class			
	C20/25	C25/30	C30/37	C35/45
10 to 25	2,3	2,7	3,0	3,4

Rebar connection with injection system FIS AB

#### Performance

Amplification factor  $\alpha_{lb}$ , bond efficiency factor  $k_b$ , design values of the bond strength  $f_{bd,PIR}$

**Annex C 1**

### Bond strength $f_{bd,fi}$ at increased temperature for concrete strength classes C20/25 to C35/45 (all drilling methods)

The bond strength  $f_{bd,fi}$  at increased temperature has to be calculated by the following equation:

$$f_{bd,fi} = k_{fi}(\theta) \cdot f_{bd,PIR} \cdot \frac{\gamma_c}{\gamma_{m,fi}}$$

If:  $\theta > 74 \text{ °C}$        $k_{fi}(\theta) = \frac{24,308 \cdot e^{-0,012 \cdot \theta}}{f_{bd,PIR} \cdot 4,3} \leq 1.0$

If:  $\theta > \theta_{max} (317 \text{ °C})$        $k_{fi}(\theta) = 0$

- $f_{bd,fi}$  = Bond strength at increased temperature in N/mm<sup>2</sup>
- $(\theta)$  = Temperature in °C in the mortar layer
- $k_{fi}(\theta)$  = Reduction factor at increased temperature
- $f_{bd,PIR}$  = Design value of the bond strength in N/mm<sup>2</sup> in cold condition according to table C1.3 considering the concrete classes, the rebar diameter, the drilling method and the bond conditions according to EN 1992-1-1:2004+AC:2010
- $\gamma_c$  = 1,5 recommended partial factor according to EN 1992-1-1:2004+AC:2010
- $\gamma_{m,fi}$  = 1,0 recommended partial factor

For evidence at increased temperature the anchorage length shall be calculated according to EN 1992-1-1:2004+AC:2010 Equation 8.3 using the temperature-dependent bond strength  $f_{bd,fi}$ .

**Figure C3.1:** Example graph of reduction factor  $k_{fi}(\theta)$  for concrete class C20/25 for good bond conditions

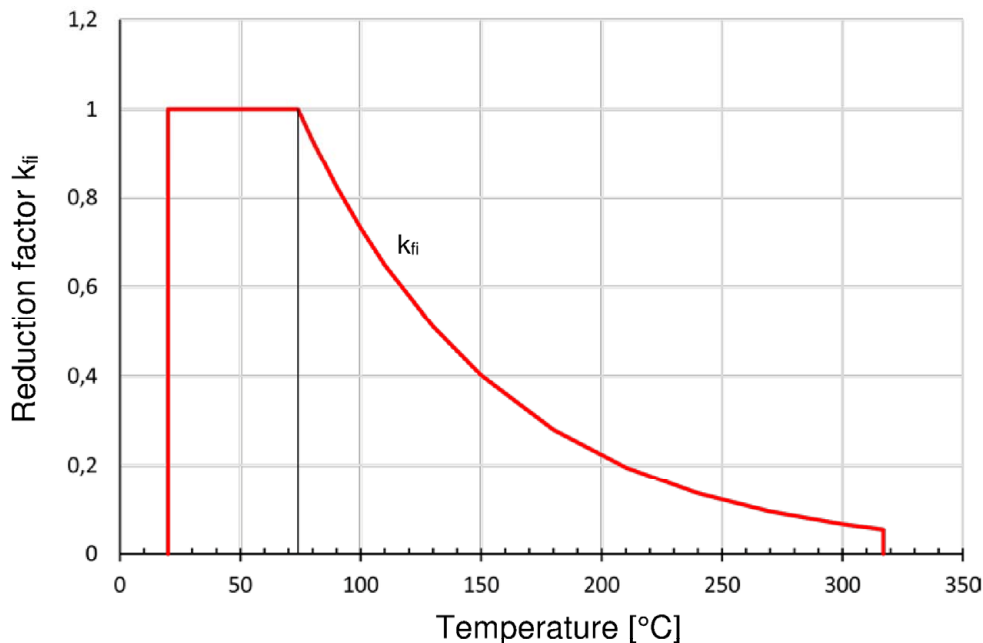

Rebar connection with injection system FIS AB

**Performance**  
Bond strength  $f_{bd,fi}$  at increased temperature

**Annex C 2**