

Public-law institution jointly founded by the
federal states and the Federation

European Technical Assessment Body
for construction products



European Technical Assessment

ETA-22/0674
of 25 March 2026

English translation prepared by DIBt - Original version in German language

General Part

Technical Assessment Body issuing the
European Technical Assessment:

Deutsches Institut für Bautechnik

Trade name of the construction product

fischer Strong Undercut Anchor FSU

Product family
to which the construction product belongs

Mechanical fastener for use in concrete

Manufacturer

fischerwerke GmbH & Co. KG
Klaus-Fischer-Straße 1
72178 Waldachtal
GERMANY

Manufacturing plant

fischerwerke

This European Technical Assessment
contains

25 pages including 3 annexes which form an integral part
of this assessment

This European Technical Assessment is
issued in accordance with Article 95(4) of
Regulation (EU) No 2024/3110, on the basis of

EAD 330232-02-0601

This version replaces

ETA-22/0674 issued on 12 April 2024

The European Technical Assessment is issued by the Technical Assessment Body in its official language. Translations of this European Technical Assessment in other languages shall fully correspond to the original issued document and shall be identified as such.

Communication of this European Technical Assessment, including transmission by electronic means, shall be in full. However, partial reproduction may only be made with the written consent of the issuing Technical Assessment Body. Any partial reproduction shall be identified as such.

This European Technical Assessment may be withdrawn by the issuing Technical Assessment Body, in particular pursuant to information by the Commission in accordance with Article 36(3) of Regulation (EU) No 2024/3110.

Specific part

1 Technical description of the product

The fischer Strong Undercut Anchor is an anchor made of galvanised steel or of stainless steel which is placed in a cylindrical hole and anchored by displacement-controlled, self-undercutted mechanical interlock.

The product description is given in Annex A.

2 Specification of the intended use in accordance with the applicable European Assessment Document

The performances given in Section 3 are only valid if the anchor is used in compliance with the specifications and conditions given in Annex B.

The verifications and assessment methods on which this European Technical Assessment is based lead to the assumption of a working life of the anchor of at least 50 years and 100 years. The indications given on the working life cannot be interpreted as a guarantee given by the producer, but are to be regarded only as a means for choosing the right products in relation to the expected economically reasonable working life of the works.

3 Performance of the product and references to the methods used for its assessment

3.1 Mechanical resistance and stability (BWR 1)

Essential characteristic	Performance
Characteristic resistance to tension load (static and quasi-static loading), Method A	See Annex C1 and C4
Characteristic resistance to shear load (static and quasi-static loading)	See Annex C2 and C3
Displacements	See Annex C9
Stiffness	See Annex C11
Characteristic resistance and displacements for seismic performance categories C1 and C2	See Annex C7, C8 and C10

3.2 Safety in case of fire (BWR 2)

Essential characteristic	Performance
Reaction to fire	Class A1
Resistance to fire	See Annex C5 and C6

3.3 Aspects of Durability

Essential characteristic	Performance
Durability	See Annex B1

4 Assessment and verification of constancy of performance (AVCP) system applied, with reference to its legal base

In accordance with the European Assessment Document EAD 330232-02-0601 the applicable European legal act is: [96/582/EC].

The system to be applied is: 1

5 Technical details necessary for the implementation of the AVCP system, as provided for in the applicable EAD

Technical details necessary for the implementation of the AVCP system are laid down in the control plan deposited with Deutsches Institut für Bautechnik.

Issued in Berlin on 25 March 2026 by Deutsches Institut für Bautechnik

Dipl.-Ing. Beatrix Wittstock
Head of Section

beglaubigt:
Ziegler

Pre-setting anchor FSU / FSU R

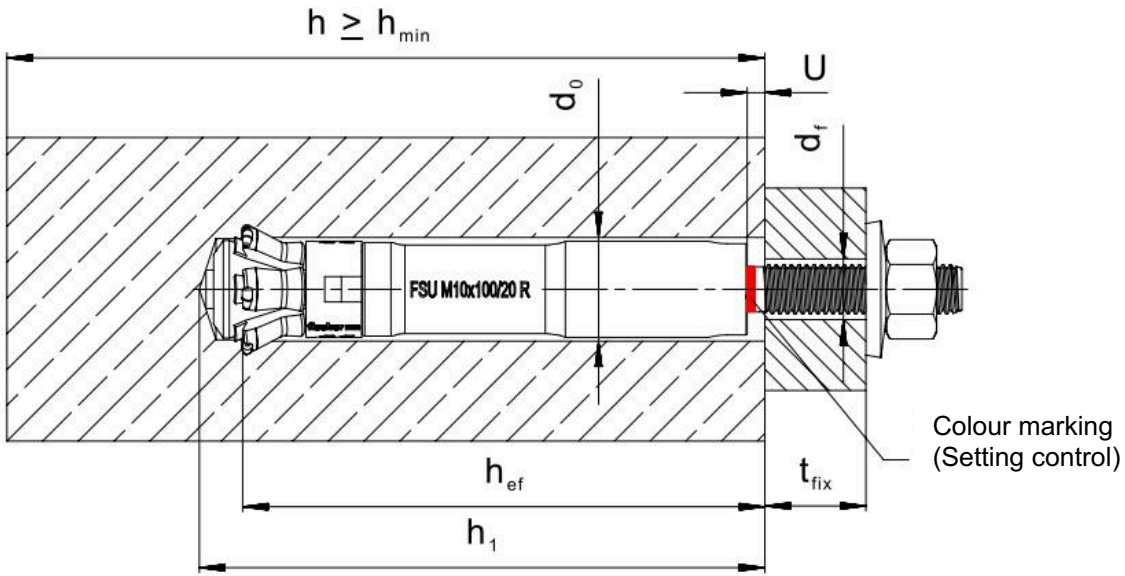

Push-through anchor FSU-P / FSU-P R

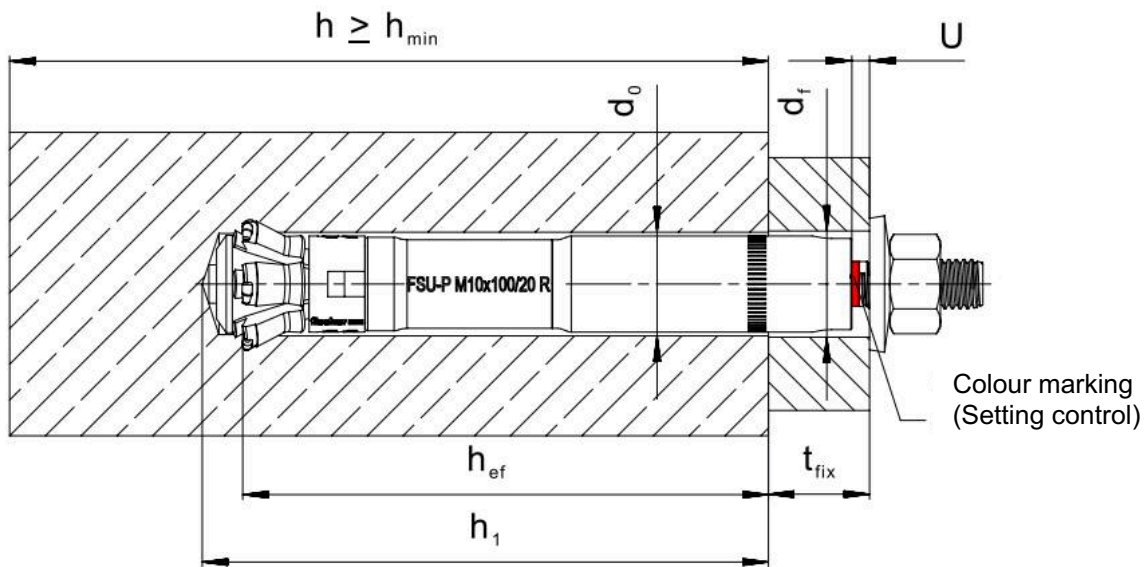

Legend

- d_0 = Nominal drill hole diameter
- d_f = Diameter of clearance hole in the fixture
- h_{ef} = Effective embedment depth
- h_1 = Depth of drill hole to deepest point
- h = Thickness of member
- t_{fix} = Thickness of fixture
- U = Gap after setting

(Figures not to scale)

fischer Strong Undercut Anchor FSU

Product description
Installed condition

Annex A1

Pre-setting anchor FSU / FSU R

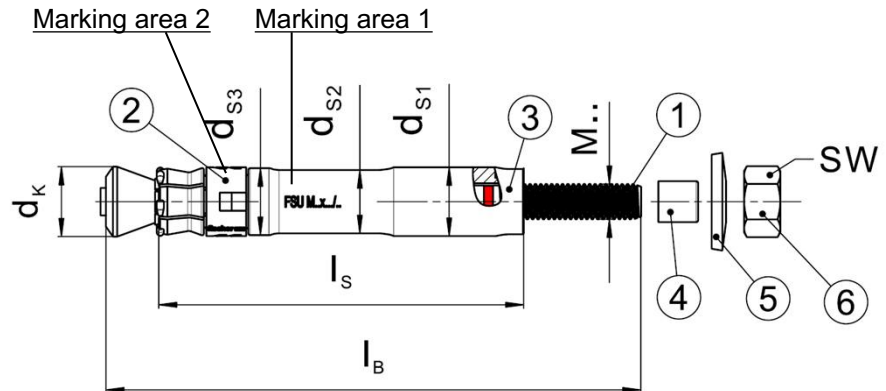

Push-through anchor FSU-P / FSU-P R

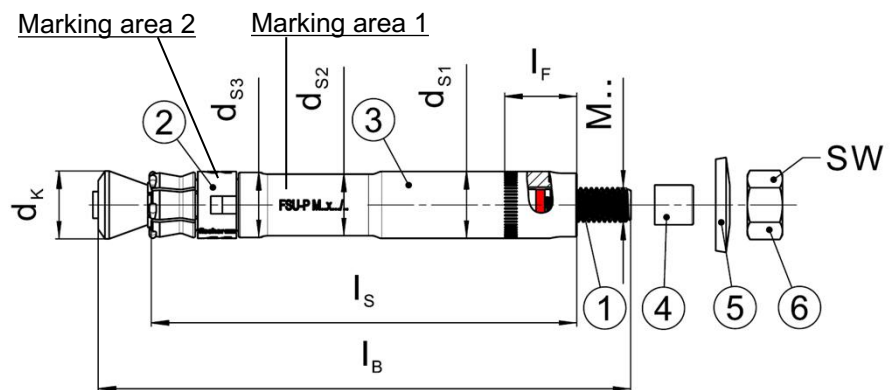

Product marking, example: FSU-P M10x100/20 R optional: Brand

Type of fastener Identification R (stainless steel version)
Thread size x effective embedment depth (h_{ef}) / Maximum thickness of the fixture (t_{fix})

Table A6.1: Dimensions [mm]

Type of anchor	t_{fix}	d_k	d_{s1}	d_{s2}	d_{s3}	M	l_s	l_B	l_F	SW
FSU M10x100/20 (R)	≤ 20	19,3	19,0	17,5	18,5	10	100	148	-	17
FSU M12x125/30 (R)	≤ 30	21,5	21,0	19,3	20,5	12	125	188	-	19
FSU M12x125/50 (R)	≤ 50	21,5	21,0	19,3	20,5	12	125	208	-	19
FSU M16x190/40 (R)	≤ 40	29,0	29,0	26,5	28,5	16	191	273	-	24
FSU M16x190/60 (R)	≤ 60	29,0	29,0	26,5	28,5	16	191	293	-	24
FSU-P M10x100/20 (R)	$\geq 10 \leq 20$	19,3	19,0	17,5	18,5	10	120	148	20	17
FSU-P M12x125/30 (R)	$\geq 12 \leq 30$	21,5	21,0	19,3	20,5	12	155	188	30	19
FSU-P M12x125/50 (R)	$\geq 12 \leq 50$	21,5	21,0	19,3	20,5	12	175	208	50	19
FSU-P M16x190/40 (R)	$\geq 15 \leq 40$	29,0	29,0	26,5	28,5	16	231	273	40	24
FSU-P M16x190/60 (R)	$\geq 15 \leq 60$	29,0	29,0	26,5	28,5	16	251	293	60	24

(Figures not to scale)

fischer Strong Undercut Anchor FSU

Product description
Product description and dimensions

Annex A2

Table A3.1: Materials FSU

Part	Designation	Material	
		FSU, FSU-P	FSU R, FSU-P R
1	Cone bolt	Steel, zinc plated $\geq 5 \mu\text{m}$, EN ISO 4042:2022	Stainless steel according to EN 10088:2023
2	Plastic sleeve	Plastic	
3	Sleeve	Steel, zinc plated $\geq 5 \mu\text{m}$, EN ISO 4042:2022	Stainless steel according to EN 10088:2023
4	Protective cap	Plastic	
5	Washer	Steel, zinc plated $\geq 5 \mu\text{m}$, EN ISO 4042:2022	Stainless steel according to EN 10088:2023
6	Hexagon nut	Steel, zinc plated $\geq 5 \mu\text{m}$, EN ISO 4042:2022	Stainless steel A4-80

Stop drill bit FSU-SD

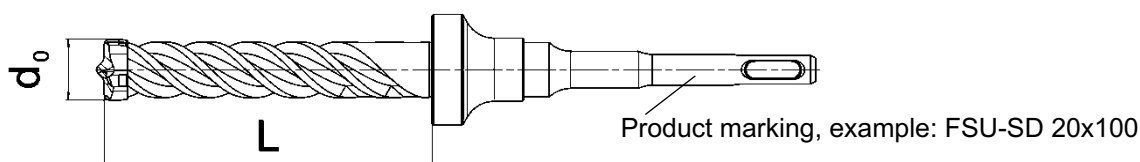

Table A3.2: Required stop drill bits for FSU

Type of anchor	Type of stop drill bit	d_0 [mm]	L [mm]
FSU M10x100/20 (R)	FSU-SD 20x100	20	107
FSU M12x125/30 (R)	FSU-SD 22x125	22	132
FSU M12x125/50 (R)			
FSU M16x190/40 (R)	FSU-SD 30x190	30	200
FSU M16x190/60 (R)			
FSU-P M10x100/20 (R)	FSU-SD 20x120	20	127
FSU-P M12x125/30 (R)	FSU-SD 22x155	22	162
FSU-P M12x125/50 (R)	FSU-SD 22x175	22	182
FSU-P M16x190/40 (R)	FSU-SD 30x230	30	240
FSU-P M16x190/60 (R)	FSU-SD 30x250	30	260

(Figure not to scale)

fischer Strong Undercut Anchor FSU

Product description
Materials and stop drill bits

Annex A3

Machine setting tool FSU-ST

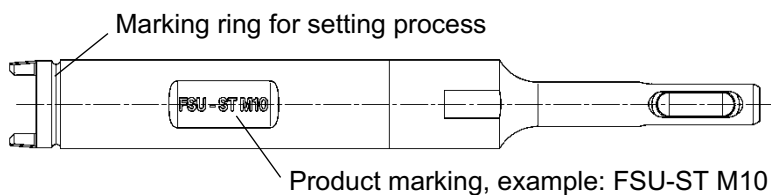

Table A4.1: Required machine setting tools for FSU

Type of anchor	Type of machine setting tool
FSU M10x100/20 (R)	FSU-ST M10
FSU M12x125/30 (R)	FSU-ST M12
FSU M12x125/50 (R)	
FSU M16x190/40 (R)	FSU-ST M16
FSU M16x190/60 (R)	
FSU-P M10x100/20 (R)	FSU-ST M10
FSU-P M12x125/30 (R)	FSU-ST M12
FSU-P M12x125/50 (R)	
FSU-P M16x190/40 (R)	FSU-ST M16
FSU-P M16x190/60 (R)	

Table A4.2: Recommendations for hammer drills used with FSU-ST

Technical feature		Recommendation FSU, FSU-P, FSU R, FSU-P R		
		M10x100	M12x125	M16x190
Drill chuck	[-]	SDS plus		SDS Max
Hammer drilling RPM	[U/min]	600 - 1800		200 - 700
Hammer impact energy	[J]	2,5 - 6		8 - 13

(Figure not to scale)

fischer Strong Undercut Anchor FSU

Product description
Setting tools

Annex A4

Specifications of intended use with working life 50 and 100 years

Fastenings subject to:

Size	FSU, FSU R, FSU-P, FSU-P R				
	M10x100/20	M12x125/30	M12x125/50	M16x190/40	M16x190/60
Static and quasi-static loads					
Cracked and uncracked concrete					
Seismic loads	C1		✓		
performance category	C2				
Fire exposure					

Base materials:

- Compacted reinforced and unreinforced normal weight concrete without fibres (cracked and uncracked) according to EN 206:2013+A2:2021.
- Strength classes C20/25 to C50/60 according to EN 206:2013+A2:2021.

Use conditions (Environmental conditions):

- Structures subject to dry internal conditions (FSU, FSU-P, FSU R, FSU-P R).
- For all other conditions according to EN 1993-1-4:2006 + A1:2015 corresponding to corrosion resistance class CRC III: FSU R, FSU-P R.

Design:

- Anchorages are designed under the responsibility of an engineer experienced in anchorages and concrete work.
- Verifiable calculation notes and drawings are prepared taking account of the loads to be anchored. The position of the anchor is indicated on the design drawings (e.g. position of the anchor relative to reinforcement or to supports, etc.).
- Anchorages are designed in accordance with EN 1992-4:2018.
- For requirements to resistance to fire local spalling of the concrete cover must be avoided.
- The stiffness characteristics k_A - k_D (Annex C11) are intended to be used in finite element calculations, such as linear- and non-linear spring models, for the design of the fastener as a function of fastener displacements and the anchor plate stiffness.

fischer Strong Undercut Anchor FSU

**Intended Use
Specifications**

Annex B1

Table B2.1: Installation parameters

Size	FSU, FSU R			FSU-P, FSU-P R		
	M10x100 /20	M12x125 /30	M12x125 /50	M10x100 /20	M12x125 /30	M12x125 /50
Nominal drill hole diameter d_0	20	22	22	20	22	22
Cutting diameter of drill bits $d_{cut} \leq$	20,5	22,5	22,5	20,5	22,5	22,5
Depth of drill hole to deepest point $h_1 \geq$	107	132	132	127- t_{fix}	162- t_{fix}	182- t_{fix}
Effective embedment depth $h_{ef} \geq$	100	125	125	100	125	125
Diameter of clearance hole in the fixture $d_f \leq$	12	14	14	21	23	23
Thickness of the fixture t_{fix}	≤ 20	≤ 30	≤ 50	$\geq 10 \leq 20$	$\geq 12 \leq 30$	$\geq 12 \leq 50$
Gap after setting U	2 - 5	3 - 6	3 - 6	2 - 5	3 - 6	3 - 6
Required setting torque T_{inst} [Nm]	40	80	80	40	80	80

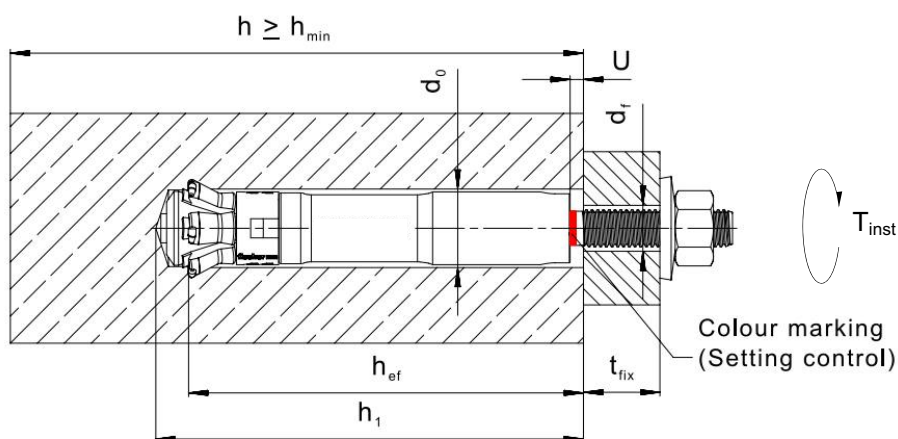

FSU (R)

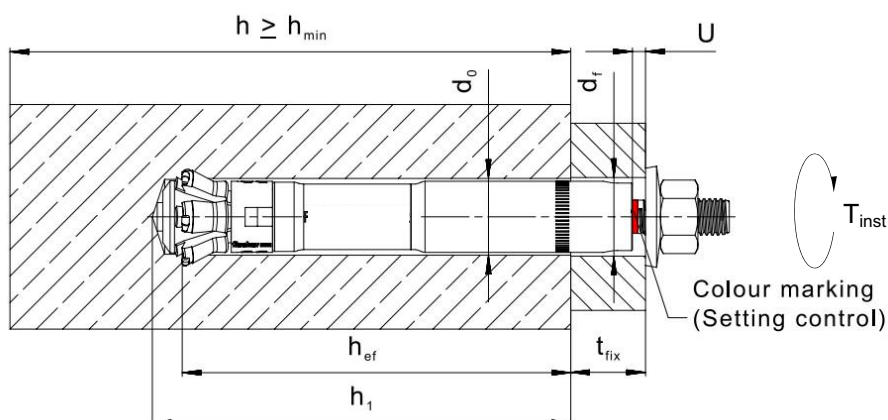

FSU-P (R)

(Figures not to scale)

fischer Strong Undercut Anchor FSU

Intended Use
Installation parameters

Annex B2

Table B3.1: Installation parameters

Size	FSU, FSU R		FSU-P, FSU-P R	
	M16x190 /40	M16x190 /60	M16x190 /40	M16x190 /60
Nominal drill hole diameter	d_0	30	30	30
Cutting diameter of drill bits	$d_{cut} \leq$	30,55	30,55	30,55
Depth of drill hole to deepest point	$h_1 \geq$	200	200	240- t_{fix}
Effective embedment depth	$h_{ef} \geq$	190	190	190
Diameter of clearance hole in the fixture	$d_f \leq$	18	18	32
Thickness of the fixture	t_{fix}	≤ 40	≤ 60	$\geq 15 \leq 40$
Gap after setting	U	3 - 8	3 - 8	3 - 8
Required setting torque	T_{inst} [Nm]	120	120	120

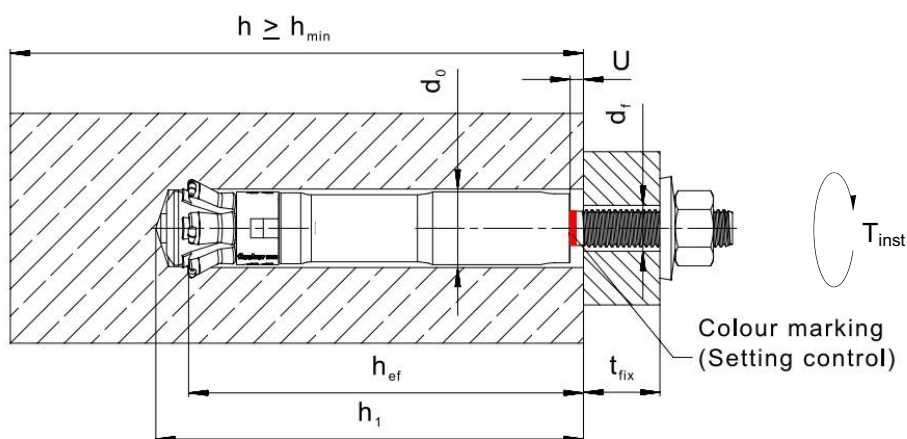

FSU (R)

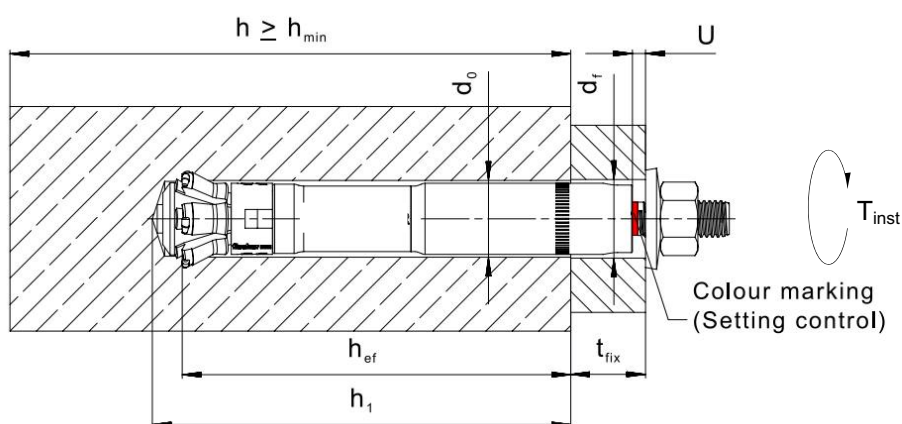

FSU-P (R)

(Figures not to scale)

fischer Strong Undercut Anchor FSU

Intended Use
Installation parameters

Annex B3

Installation instructions

- Fastener installation carried out by appropriately qualified personnel according to the design drawings and under the supervision of the person responsible for technical matters on the site.
- Use of the fastener only as supplied by the manufacturer without exchanging the components of the fastener.
- Fastener installation in accordance with the manufacturer's specifications and drawings and using the appropriate tools (machine setting tool FSU-ST, stop drill bit FSU-SD).
- Drill hole created perpendicular (tolerance +/- 5°) to concrete surface.
- Cleaning the hole of drilling dust.
- Fastener installation ensuring complete expansion of the sleeve with checking that the coloured ring marking on the bolt is visible above the top edge of the anchor sleeve, therefore it is required using the setting tool FSU-ST, that is the appropriate depth ring marking of the setting tool at least flush with the concrete surface (pre-setting) respecting with the fixture surface (Push-through-setting).
- Fastener installation ensuring complete shear load capacity, after setting the gap between the top edge of the sleeve and the concrete surface (pre-setting) or with surface of the fixture (Push-through-setting) has to be in the specified range according to Annex B2 Table B2.1 or Annex B3 Table B3.1, respectively.
- Positioning of the drill holes and the undercut without damaging the reinforcement.
- In case of aborted hole: new drilling at a minimum distance twice the depth of the aborted drill hole or smaller distance, if the aborted drill hole is filled with high strength mortar and, if under shear or oblique tension load, it is not in the direction of load application.
- Application of the torque moment given in Annex B2 Table B2.1 or Annex B3 Table B3.1, respectively, using a calibrated torque wrench.

fischer Strong Undercut Anchor FSU

Intended Use
Installation instructions

Annex B4

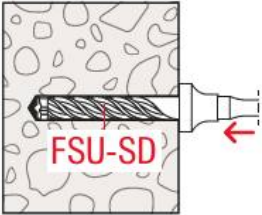
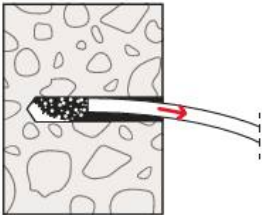
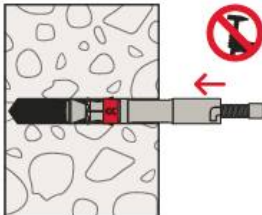
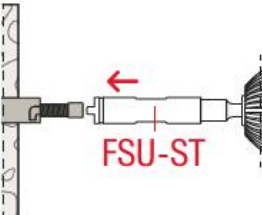
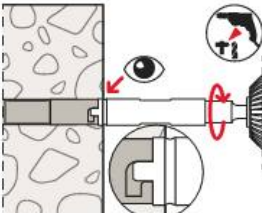
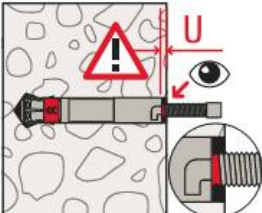
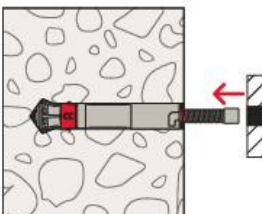
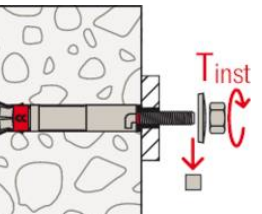
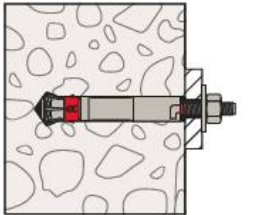
Installation instructions for pre-setting anchor FSU, FSU R	
<p>1) </p> <p>2) </p>	<p>1) Drill the hole with the designated stop drill bit FSU-SD (see Table A3.2).</p> <p>2) Clean the hole.</p>
<p>3) </p> <p>4) </p>	<p>3) Place the anchor in the hole by hand. Do not use any hammering tools.</p> <p>4) Use the designated setting tool FSU-ST (see Table A4.1) and follow the recommendations for the hammer drill (see Table A4.2).</p>
<p>5) </p> <p>6) </p>	<p>5) Place the setting tool in the grooves provided on the anchor. Carry out the setting process with the rotary-impact mode of the hammer drill. The setting process is completed when the marking ring of the setting tool is flush with the concrete surface.</p> <p>6) After removing the setting tool, the red coloured ring marking on the bolt must be visible above the top edge of the anchor sleeve. The gap U between the top edge of the sleeve and the concrete surface must be in the specified range according to Table B2.1 or B3.1, respectively.</p>
<p>7) </p> <p>8) </p>	<p>7) Place the fixture.</p> <p>8) Remove the protective cap. Place the spring washer and the hexagon nut on the bolt. Take care of the right orientation of the spring washer, in the way, that the outer diameter of the washer in uncompressed condition is in touch with the fixture, only. Apply the installation torque.</p>
<p>9) </p>	<p>9) Correctly installed fastener.</p>
<p>fischer Strong Undercut Anchor FSU</p>	
<p>Intended Use Installation instructions</p>	
<p>Annex B5</p>	

Installation instructions for push-through anchor FSU-P, FSU-P R

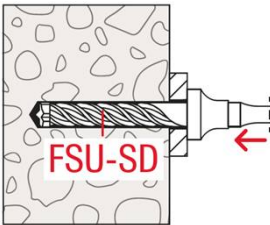
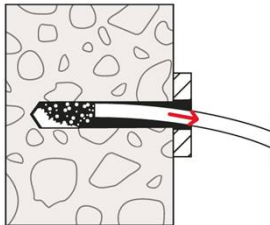
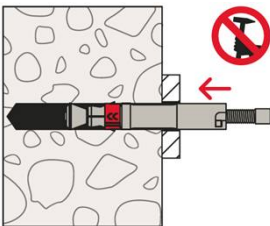
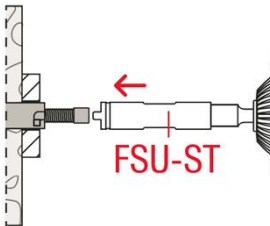
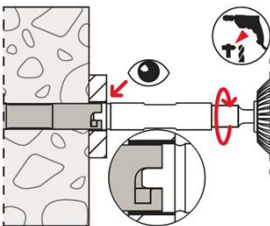
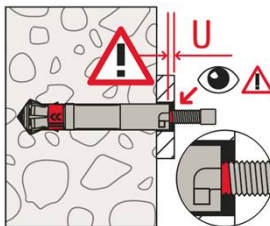
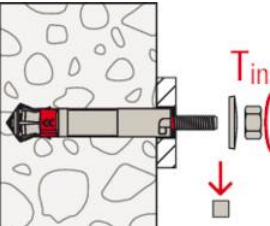
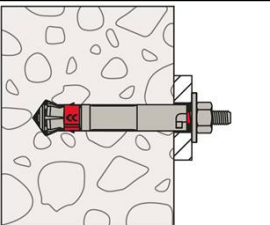
<p>1) </p>	<p>2) </p>	<p>1) Drill the hole with the designated stop drill bit FSU-SD (see table A3.2) in compliance with the specified range of fixture thicknesses (see Table B2.1 or B3.1, respectively). 2) Clean the hole.</p>
<p>3) </p>	<p>4) </p>	<p>3) Place the anchor in the hole by hand. Do not use any hammering tools. 4) Use the designated setting tool FSU-ST (see Table A4.1) and follow the recommendations for the hammer drill (see Table A4.2).</p>
<p>5) </p>	<p>6) </p>	<p>5) Place the setting tool in the grooves provided on the anchor. Carry out the setting process with the rotary-impact mode of the hammer drill. The setting process is completed when the marking ring of the setting tool is flush with the fixture surface. 6) After removing the setting tool, the red coloured ring marking on the bolt must be visible above the top edge of the anchor sleeve. The gap U between the top edge of the sleeve and the fixture surface must be in the specified range according to Table B2.1 or Table B3.1, respectively.</p>
<p>7) </p>		<p>7) Remove the protective cap. Place the spring washer and the hexagon nut on the bolt. Take care of the right orientation of the spring washer, in the way, that the outer diameter of the washer in uncompressed condition is in touch with the fixture, only. Apply the installation torque.</p>
<p>8) </p>		<p>8) Correctly installed fastener.</p>

fischer Strong Undercut Anchor FSU

Intended Use
Installation instructions

Annex B6

Table C1.1: Characteristic tension resistance under static and quasi-static action for a working life of 50 and 100 years

Size			FSU, FSU-P, FSU R, FSU-P R			
			M10x100	M12x125	M16x190	
Steel failure						
Characteristic resistance	$N_{Rk,s}$	[kN]	46,4	67,4	125,6	
Partial factor for steel failure	γ_{Ms}	[-]	1,5			
Pullout failure						
Characteristic resistance in C20/25	cracked concrete	$N_{Rk,p,cr} = N_{Rk,p,cr,50}$	46,4	67,4	125,6	
		$N_{Rk,p,cr} = N_{Rk,p,cr,100}$		63,4		
	uncracked concrete	$N_{Rk,p,ucr} = N_{Rk,p,ucr,100}$		67,4		
Increasing factor for $N_{Rk,p}$, $N_{Rk,p,100}$ $N_{Rk,p} = \psi_c * N_{Rk,p} (C20/25)$ $N_{Rk,p,100} = \psi_c * N_{Rk,p,100} (C20/25)$		$\psi_c =$	C25/30	1,12		
		$\psi_{c,cr} =$	C30/37	1,22		
		$\psi_{c,ucr}$	C35/45	1,32		
		[-]	C40/50	1,41		
				C45/55	1,50	
				C50/60	1,58	
Installation sensitivity factor	γ_{inst}	[-]	1,0			
Concrete cone and splitting failure						
Effective embedment depth	h_{ef}	[mm]	100	125	190	
Factor for cracked concrete	$k_{cr,N}$	[-]	8,9			
Factor for uncracked concrete	$k_{ucr,N}$		12,7			
Characteristic spacing	$s_{cr,N}$	[mm]	3 x h_{ef}			
Characteristic edge distance	$c_{cr,N}$		1,5 x h_{ef}			
Characteristic spacing for splitting failure	$s_{cr,sp}$		3 x h_{ef}			
Characteristic edge distance for splitting failure	$c_{cr,sp}$		1,5 x h_{ef}			
Characteristic resistance for splitting failure	$N_{Rk,sp}^0$		[kN]	$\min \{N_{Rk,c}^0; N_{Rk,p}\}^{1)}$		

1) $N_{Rk,c}^0$ according to EN 1992-4:2018.

fischer Strong Undercut Anchor FSU

Performances

Characteristic tension resistance under static and quasi-static action for a working life of 50 and 100 years

Annex C1

Table C2.1: Characteristic shear resistance under static and quasi-static action for a working life of 50 and 100 years

Size			FSU, FSU R	
			M10x100	M12x125
Steel failure without lever arm				
Characteristic resistance	$\frac{V_{Rk,s}^0}{V_{Rk,s}^0}$ FSU	[kN]	26,8	38,2
	FSU R		32,9	49,9
Partial factor for steel failure	γ_{Ms}	[-]	1,25	
Factor for ductility	k_7		1,0	
Steel failure with lever arm				
Characteristic bending resistance	$M_{Rk,s}^0$	[Nm]	59,8	104,8
Partial factor for steel failure	γ_{Ms}	[-]	1,25	
Concrete pryout failure				
Factor for pryout failure	k_8	[-]	2,5	
Concrete edge failure				
Effective length in concrete	l_f	[mm]	100	125
Effective diameter of fastener	d_{nom}		19	21

Table C2.2: Characteristic shear resistance under static and quasi-static action for a working life of 50 and 100 years

Size			FSU, FSU R	
			M16x190	
Steel failure without lever arm				
Characteristic resistance	$\frac{V_{Rk,s}^0}{V_{Rk,s}^0}$ FSU	[kN]	69,1	
	FSU R		87,9	
Partial factor for steel failure	γ_{Ms}	[-]	1,25	
Factor for ductility	k_7		1,0	
Steel failure with lever arm				
Characteristic bending resistance	$M_{Rk,s}^0$	[Nm]	266,4	
Partial factor for steel failure	γ_{Ms}	[-]	1,25	
Concrete pryout failure				
Factor for pryout failure	k_8	[-]	2,5	
Concrete edge failure				
Effective length in concrete	l_f	[mm]	190	
Effective diameter of fastener	d_{nom}		29	

fischer Strong Undercut Anchor FSU

Performances

Characteristic shear resistance under static and quasi-static action for a working life of 50 and 100 years

Annex C2

Table C3.1: Characteristic shear resistance under static and quasi-static action for a working life of 50 and 100 years

Size			FSU-P, FSU-P R			
			M10x100		M12x125	
Steel failure without lever arm						
Characteristic resistance	for t_{fix}	[mm]	$10 \leq t_{fix} < 15$	$15 \leq t_{fix} \leq 20$	$12 \leq t_{fix} < 20$	$20 \leq t_{fix} \leq 50$
	$V_{RK,s}^0$ FSU-P	[kN]	66,1	69,6	86,4	96,7
	$V_{RK,s}^0$ FSU-P R		74,6	80,6	102,9	103,6
Partial factor for steel failure	γ_{Ms}	[-]	1,25			
Factor for ductility	k_7	[-]	1,0			
Steel failure with lever arm						
Characteristic bending resistance	$M_{RK,s}^0$	[Nm]	59,8		104,8	
Partial factor for steel failure	γ_{Ms}	[-]	1,25			
Concrete pryout failure						
Factor for pryout failure	k_8	[-]	2,5			
Concrete edge failure						
Effective length in concrete	l_f	[mm]	100		125	
Effective diameter of fastener	d_{nom}		19		21	

Table C3.2: Characteristic shear resistance under static and quasi-static action for a working life of 50 and 100 years

Size			FSU-P, FSU-P R	
			M16x190	
Steel failure without lever arm				
Characteristic resistance	for t_{fix}	[mm]	$15 \leq t_{fix} < 40$	$40 \leq t_{fix} \leq 60$
	$V_{RK,s}^0$ FSU-P	[kN]	178,8	226,7
	$V_{RK,s}^0$ FSU-P R		214,7	286,7
Partial factor for steel failure	γ_{Ms}	[-]	1,25	
Factor for ductility	k_7	[-]	1,0	
Steel failure with lever arm				
Characteristic bending resistance	$M_{RK,s}^0$	[Nm]	266,4	
Partial factor for steel failure	γ_{Ms}	[-]	1,25	
Concrete pryout failure				
Factor for pryout failure	k_8	[-]	2,5	
Concrete edge failure				
Effective length in concrete	l_f	[mm]	190	
Effective diameter of fastener	d_{nom}		29	

fischer Strong Undercut Anchor FSU

Performances

Characteristic shear resistance under static and quasi-static action for a working life of 50 and 100 years

Annex C3

Table C4.1: Minimum thickness of concrete members

Size	FSU, FSU R				
	M10x100/20	M12x125/30	M12x125/50	M16x190/40	M16x190/60
Minimum thickness of concrete member h_{\min} [mm]	170	215		270	

Table C4.2: Minimum thickness of concrete members

Size	FSU-P, FSU-P R				
	M10x100/20	M12x125/30	M12x125/50	M16x190/40	M16x190/60
Maximum thickness of the fixture $t_{\text{fix,max}}$ [mm]	20	30	50	40	60
Minimum thickness of concrete member h_{\min}	$190-t_{\text{fix}}^{1)}$	$245-t_{\text{fix}}^{1)}$	$265-t_{\text{fix}}^{1)}$	$310-t_{\text{fix}}^{1)}$	$330-t_{\text{fix}}^{1)}$

¹⁾ t_{fix} = actual thickness of the fixture.

Table C4.3: Minimum spacings and edge distances

Size	FSU, FSU-P, FSU R, FSU-P R				
	M10x100/20	M12x125/30	M12x125/50	M16x190/40	M16x190/60
Minimum spacing s_{\min} [mm]	80	90		100	
Minimum edge distance c_{\min}	80	90		100	

fischer Strong Undercut Anchor FSU

Performances

Minimum thickness of concrete member, minimum spacings and edge distances

Annex C4

Table C5.1: Characteristic tension resistance under fire exposure for a working life of 50 and 100 years

Size	FSU, FSU-P		FSU R, FSU-P R				
	M10x100	M12x125	M10x100	M12x125			
Characteristic resistance steel failure	$N_{Rk,s,fi}$	[kN]	R30	3,7	4,5	7,2	10,4
			R60	2,2	3,2	5,3	7,7
			R90	1,7	2,8	4,7	6,9
			R120	1,5	2,6	4,4	6,4
Characteristic resistance Concrete cone failure	$N_{Rk,c,fi}$	[kN]	R30-R90	19,9	34,8	19,9	34,8
			R120	15,9	27,8	15,9	27,8
Characteristic resistance pullout failure	$N_{Rk,p,fi,50}$	[kN]	R30-R90	11,6	16,9	11,6	16,9
			R120	9,3	13,5	9,3	13,5
	$N_{Rk,p,fi,100}$		R30-R90	11,6	15,9	11,6	15,9
			R120	9,3	12,7	9,3	12,7

Table C5.2: Characteristic tension resistance under fire exposure for a working life of 50 and 100 years

Size	FSU, FSU-P		FSU R, FSU-P R		
	M16x190		M16x190		
Characteristic resistance steel failure	$N_{Rk,s,fi}$	[kN]	R30	7,9	19,4
			R60	5,6	14,4
			R90	4,9	12,8
			R120	4,5	11,9
Characteristic resistance Concrete cone failure	$N_{Rk,c,fi}$	[kN]	R30-R90	99,0	99,0
			R120	79,2	79,2
Characteristic resistance pullout failure	$N_{Rk,p,fi}$	[kN]	R30-R90	31,4	31,4
			R120	25,1	25,1

Table C5.3: Characteristic shear resistance under fire exposure for a working life of 50 and 100 years

Size	FSU, FSU-P		FSU R, FSU-P R				
	M10x100	M12x125	M10x100	M12x125			
Characteristic resistance steel failure without lever arm	$V_{Rk,s,fi}$	[kN]	R30	3,7	4,5	7,2	10,4
			R60	2,2	3,2	5,3	7,7
			R90	1,7	2,8	4,7	6,9
			R120	1,5	2,6	4,4	6,4
Characteristic bending resistance steel failure with lever arm	$M^0_{Rk,s,fi}$	[Nm]	R30	4,8	6,9	9,2	16,2
			R60	2,9	5,0	6,9	12,0
			R90	2,2	4,4	6,1	10,6
			R120	1,9	4,0	5,7	10,0
Concrete failure $V^0_{Rk,c,fi}$ and $V_{Rk,cp,fi}$			According to EN 1992-4:2018				

fischer Strong Undercut Anchor FSU

Performances

Characteristic resistance under fire exposure for a working life of 50 and 100 years

Annex C5

Table C6.1: Characteristic shear resistance under fire exposure for a working life of 50 and 100 years

Size		FSU, FSU-P M16x190	FSU R, FSU-P R M16x190
Characteristic resistance steel failure without lever arm	$V_{Rk,s,fi}$		
	R30	7,9	19,4
	R60	5,6	14,4
	R90	4,9	12,8
	R120	4,5	11,9
Characteristic bending resistance steel failure with lever arm	$M^0_{Rk,s,fi}$		
	R30	16,7	41,2
	R60	11,9	30,6
	R90	10,3	27,1
	R120	9,5	25,3
Concrete failure $V^0_{Rk,c,fi}$ and $V_{Rk,cp,fi}$		According to EN 1992-4:2018	

Table C6.2: Minimum spacings and minimum edge distances under fire exposure for tension and shear load

Size		FSU, FSU-P, FSU R, FSU-P R All sizes
Minimum spacing	$s_{min,fi}$	$4 \cdot h_{ef}$
Minimum edge distance	$c_{min,fi}$	$2 \cdot h_{ef}$, for fire exposure from more than one side $c_{min,fi} \geq 300$ mm

fischer Strong Undercut Anchor FSU

Performances
Characteristic resistance under fire exposure for a working life of 50 and 100 years
Minimum spacing and edge distance under fire exposure for tension and shear load

Annex C6

Table C7.1: Characteristic values of tension and shear resistance under seismic performance category C1 for a working life of 50 and 100 years					
Size				FSU, FSU-P, FSU R, FSU-P R	
				M10x100	M12x125
Factor for annular gap	without filling of annular gap	α_{gap}	[-]	0,5	
Steel failure					
Characteristic resistance tension load seismic performance category C1		$N_{\text{Rk,s,C1}}$	[kN]	46,4	67,4
Pullout failure					
Characteristic resistance tension load in cracked concrete seismic performance category C1		$N_{\text{Rk,p,C1}} = N_{\text{Rk,p,C1,50}}$	[kN]	46,4	67,4
		$N_{\text{Rk,p,C1}} = N_{\text{Rk,p,C1,100}}$			63,4
Steel failure without lever arm					
		for t_{fix}	[mm]	$10 \leq t_{\text{fix}} < 15$	$15 \leq t_{\text{fix}} \leq 20$
Characteristic resistance shear load seismic performance category C1		$V_{\text{Rk,s,C1}}$	[kN]	FSU	
		$V_{\text{Rk,s,C1}}$		FSU R	
		$V_{\text{Rk,s,C1}}$		FSU-P	
		$V_{\text{Rk,s,C1}}$		FSU-P R	
				18,8	26,8
				23,0	34,9
				46,3	67,7
				52,2	72,5
Table C7.2: Characteristic values of tension and shear resistance under seismic performance category C1 for a working life of 50 and 100 years					
Size				FSU, FSU-P, FSU R, FSU-P R	
				M16x190	
Factor for annular gap	without filling of annular gap	α_{gap}	[-]	0,5	
Steel failure					
Characteristic resistance tension load seismic performance category C1		$N_{\text{Rk,s,C1}}$	[kN]	125,6	
Pullout failure					
Characteristic resistance tension load in cracked concrete seismic performance category C1		$N_{\text{Rk,p,C1}}$	[kN]	125,6	
Steel failure without lever arm					
		for t_{fix}	[mm]	$15 \leq t_{\text{fix}} < 40$	$40 \leq t_{\text{fix}} \leq 60$
Characteristic resistance shear load seismic performance category C1		$V_{\text{Rk,s,C1}}$	[kN]	FSU	
		$V_{\text{Rk,s,C1}}$		FSU R	
		$V_{\text{Rk,s,C1}}$		FSU-P	
		$V_{\text{Rk,s,C1}}$		FSU-P R	
				62,2	
				70,3	
				89,4	120,2
				107,4	152,0
fischer Strong Undercut Anchor FSU					Annex C7
Performances Characteristic tension and shear resistance under seismic performance category C1 for a working life of 50 and 100 years					

Table C8.1: Characteristic values of tension and shear resistance under seismic performance category C2 for a working life of 50 and 100 years

Size		FSU, FSU-P, FSU R, FSU-P R								
		M10x100		M12x125						
Factor for annular gap	without filling of annular gap	α_{gap}	[-]				0,5			
Steel failure										
Characteristic resistance tension load seismic performance category C2		$N_{\text{Rk,s,C2}}$	[kN]		46,4		67,4			
Pullout failure										
Characteristic resistance tension load in cracked concrete seismic performance category C2		$N_{\text{Rk,p,C2}} = N_{\text{Rk,p,C2,50}}$	[kN]		46,4		67,4			
		$N_{\text{Rk,p,C2}} = N_{\text{Rk,p,C2,100}}$					63,4			
Steel failure without lever arm										
Characteristic resistance shear load seismic performance category C2		for t_{fix}	[mm]		$10 \leq t_{\text{fix}} < 15$	$15 \leq t_{\text{fix}} \leq 20$	$12 \leq t_{\text{fix}} < 20$	$20 \leq t_{\text{fix}} \leq 50$		
		$V_{\text{Rk,s,C2}}$ FSU	[kN]		20,1		24,5			
		$V_{\text{Rk,s,C2}}$ FSU R			22,8		31,9			
		$V_{\text{Rk,s,C2}}$ FSU-P			39,6	41,8	51,8	62,9		
$V_{\text{Rk,s,C2}}$ FSU-P R	37,2				56,6		67,3			

Table C8.2: Characteristic values of tension and shear resistance under seismic performance category C2 for a working life of 50 and 100 years

Size		FSU, FSU-P, FSU R, FSU-P R									
		M16x190									
Factor for annular gap	without filling of annular gap	α_{gap}	[-]				0,5				
Steel failure											
Characteristic resistance tension load seismic performance category C2		$N_{\text{Rk,s,C2}}$	[kN]		125,6						
Pullout failure											
Characteristic resistance tension load in cracked concrete seismic performance category C2		$N_{\text{Rk,p,C2}}$	[kN]		125,6						
Steel failure without lever arm											
Characteristic resistance shear load seismic performance category C2		for t_{fix}	[mm]		$15 \leq t_{\text{fix}} < 40$			$40 \leq t_{\text{fix}} \leq 60$			
		$V_{\text{Rk,s,C2}}$ FSU	[kN]		62,2						
		$V_{\text{Rk,s,C2}}$ FSU R			70,3						
		$V_{\text{Rk,s,C2}}$ FSU-P			89,4			120,2			
$V_{\text{Rk,s,C2}}$ FSU-P R	107,4				152,0						

fischer Strong Undercut Anchor FSU

Performances

Characteristic resistance under seismic performance categories C2 for a working life of 50 and 100 years

Annex C8

Table C9.1: Displacements under static and quasi-static tension loads for a working life of 50 and 100 years

Size			FSU, FSU-P, FSU R, FSU-P R		
			M10x100	M12x125	M16x190
Tension load in cracked concrete C20/25	N	[kN]	21,8	33,1	59,8
Displacements	δ_{N0}	[mm]	1,1	1,3	1,8
	$\delta_{N,50years}$		1,3	1,3	1,5
	$\delta_{N,100years}$				
Tension load in uncracked concrete C20/25	N	[kN]	21,8	33,1	59,8
Displacements	δ_{N0}	[mm]	1,1	1,7	1,8
	$\delta_{N,50years}$		2,8	2,8	2,4
	$\delta_{N,100years}$				2,5

Table C9.2: Displacements under static and quasi-static shear loads for a working life of 50 and 100 years

Size			FSU, FSU-P, FSU R, FSU-P R		
			M10x100	M12x125	M16x190
Shear load in cracked and uncracked concrete C20/25	V	[kN]	13,8	21,3	32,9
Displacements FSU	δ_{V0}	[mm]	5,4	6,7	2,1
	$\delta_{V\infty}$		8,0	10,0	3,2
Shear load in cracked and uncracked concrete C20/25	V	[kN]	16,9	25,6	41,9
Displacements FSU R	δ_{V0}	[mm]	2,4	3,8	4,0
	$\delta_{V\infty}$		3,6	5,8	6,0
Shear load in cracked and uncracked concrete C20/25	V	[kN]	36,3	52,2	108,0
Displacements FSU-P	δ_{V0}	[mm]	5,9	7,2	8,5
	$\delta_{V\infty}$		8,8	10,7	12,8
Shear load in cracked and uncracked concrete C20/25	V	[kN]	39,6	55,4	134,9
Displacements FSU-P R	δ_{V0}	[mm]	8,91	8,7	11,0
	$\delta_{V\infty}$		13,4	13,1	16,5

fischer Strong Undercut Anchor FSU

Performances

Displacements under static and quasi-static loads for a working life of 50 and 100 years

Annex C9

Table C10.1: Displacements under tension loads for seismic performance category C2 for a working life of 50 and 100 years

Size		FSU, FSU-P, FSU R, FSU-P R		
		M10x100	M12x125	M16x190
Displacements	$\frac{\delta_{N,C2(0,5)}}{\delta_{N,C2(0,8)}} [mm]$	4,6	4,6	2,6
		11,4	10,4	5,1

Table C10.2: Displacements under shear loads for seismic performance category C2 for a working life of 50 and 100 years

Size		FSU, FSU-P, FSU R, FSU-P R			
		M10x100		M12x125	
for t_{fix}		$10 \leq t_{fix} < 15$	$15 \leq t_{fix} \leq 20$	$12 \leq t_{fix} < 20$	$20 \leq t_{fix} \leq 50$
Displacements FSU	$\frac{\delta_{V,C2(0,5)}}{\delta_{V,C2(0,8)}} [mm]$	5,2		5,0	
		7,3		6,7	
Displacements FSU R	$\frac{\delta_{V,C2(0,5)}}{\delta_{V,C2(0,8)}} [mm]$	4,7		4,1	
		6,8		5,9	
Displacements FSU-P	$\frac{\delta_{V,C2(0,5)}}{\delta_{V,C2(0,8)}} [mm]$	4,8		5,0	
		10,7		18,5	
Displacements FSU-P R	$\frac{\delta_{V,C2(0,5)}}{\delta_{V,C2(0,8)}} [mm]$	3,7		4,2	
		7,8		13,2	

Table C10.3: Displacements under shear loads for seismic performance category C2 for a working life of 50 and 100 years

Size		FSU, FSU-P, FSU R, FSU-P R	
		M16x190	
for t_{fix}		$15 \leq t_{fix} < 40$	$40 \leq t_{fix} \leq 60$
Displacements FSU	$\frac{\delta_{V,C2(0,5)}}{\delta_{V,C2(0,8)}} [mm]$	6,1	
		8,9	
Displacements FSU R	$\frac{\delta_{V,C2(0,5)}}{\delta_{V,C2(0,8)}} [mm]$	5,8	
		9,7	
Displacements FSU-P	$\frac{\delta_{V,C2(0,5)}}{\delta_{V,C2(0,8)}} [mm]$	4,5	5,6
		7,0	13,0
Displacements FSU-P R	$\frac{\delta_{V,C2(0,5)}}{\delta_{V,C2(0,8)}} [mm]$	3,6	4,9
		5,3	16,7

fischer Strong Undercut Anchor FSU

Performances

Displacements under static and quasi-static loads for seismic performance category C2 for a working life of 50 and 100 years

Annex C10

Table C11.1: Stiffness characteristics (mean values) under static and quasi-static tension loads for a working life of 50 and 100 years

Size	FSU, FSU-P, FSU-R, FSU-P R			
	M10x100	M12x125	M16x190	
Stiffness characteristics in cracked concrete	$k_{A,cr}$	20,1	22,6	21,8
	$k_{B,cr}$	13,8	16,0	15,4
	$k_{C,cr}$	10,4	12,2	10,9
	$k_{D,cr}$	1,8	2,0	1,9
Stiffness characteristics in uncracked concrete	$k_{A,ucr}$	33,1	35,0	28,6
	$k_{B,ucr}$	25,2	24,5	23,5
	$k_{C,ucr}$	20,6	17,3	18,3
	$k_{D,ucr}$	3,7	3,4	3,3

- The stiffness characteristics k_A - k_D are intended to be used in finite element calculations, such as linear- and non-linear spring models (k_A for linear spring model and k_A - k_D for non-linear spring model), for the design of the fastener group as a function of fastener displacements and the anchor plate stiffness.
- For linear spring model: mean displacement for any load N : $\delta_{mean} = N / k_A$.

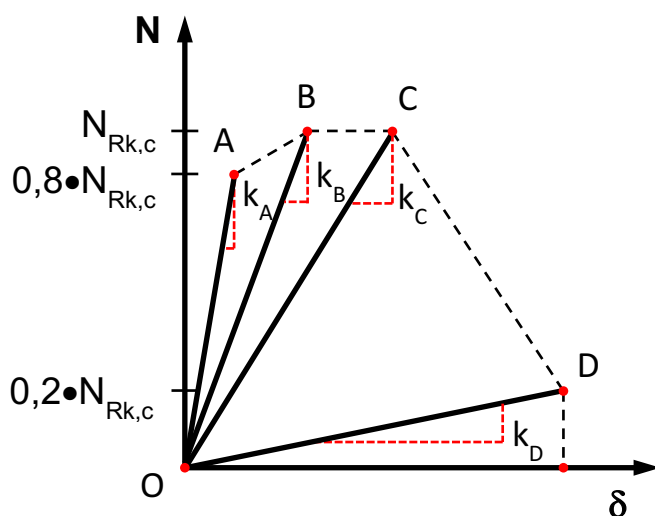

fischer Strong Undercut Anchor FSU

Performances

Stiffness characteristics under static and quasi-static loads for a working life of 50 and 100 years

Annex C11