

Approval body for construction products  
and types of construction

Bautechnisches Prüfamt

An institution established by the Federal and  
Laender Governments



## European Technical Assessment

**ETA-22/0669**  
**of 22 September 2023**

English translation prepared by DIBt - Original version in German language

### General Part

Technical Assessment Body issuing the  
European Technical Assessment:

Deutsches Institut für Bautechnik

Trade name of the construction product

fischer Zykon Plattenanker FZP II T for "LAMINAM  
ceramic"

Product family  
to which the construction product belongs

Anchor for the rear fixing of façade panels made of  
"LAMINAM, ceramic plates" according to EN 14411:2016

Manufacturer

fischerwerke GmbH & Co. KG  
Klaus-Fischer-Straße 1  
72178 Waldachtal  
DEUTSCHLAND

Manufacturing plant

fischerwerke

This European Technical Assessment  
contains

14 pages including 3 annexes which form an integral part  
of this assessment

This European Technical Assessment is  
issued in accordance with Regulation (EU)  
No 305/2011, on the basis of

330030-00-0601, Edition 10/ 2018

This version replaces

ETA-22/0669 issued on 19 December 2022

The European Technical Assessment is issued by the Technical Assessment Body in its official language. Translations of this European Technical Assessment in other languages shall fully correspond to the original issued document and shall be identified as such.

Communication of this European Technical Assessment, including transmission by electronic means, shall be in full. However, partial reproduction may only be made with the written consent of the issuing Technical Assessment Body. Any partial reproduction shall be identified as such.

This European Technical Assessment may be withdrawn by the issuing Technical Assessment Body, in particular pursuant to information by the Commission in accordance with Article 25(3) of Regulation (EU) No 305/2011.

## Specific Part

### 1 Technical description of the product

The fischer-Zykon-panel anchor FZP II T is a special anchor of size M 6 which consists of a cone bolt with external thread, made of stainless steel, an expansion part made of stainless steel, a shim washer made of polyamide and, if need to be, a hexagon nut made of stainless steel or aluminium. The anchor is put into an undercut drill hole in the façade panels and is placed form-fit by driving-in the shim washer or by applying a torque moment to the hexagon nut.

The product description is given in Annex A. The material values, dimensions and tolerances of the components of the fastener not indicated in the annexes shall correspond to the values laid down in the technical documentation.

### 2 Specification of the intended use in accordance with the applicable European Assessment Document

The performances given in Section 3 are only valid if the fastener is used in compliance with the specifications and conditions given in Annex B.

The verifications and assessment methods on which this European Technical Assessment is based lead to the assumption of a working life of the fasteners of at least 50 years. The indications given on the working life cannot be interpreted as a guarantee given by the producer, but are to be regarded only as a means for choosing the right products in relation to the expected economically reasonable working life of the works.

### 3 Performance of the product and references to the methods used for its assessment

#### 3.1 Mechanical resistance and stability (BWR 1)

Essential characteristic	Performance
Characteristic resistance to breakout or pull-out failure under tension load	See Annex C 1
Characteristic resistance to breakout or pull-out failure under shear load	See Annex C 1
Characteristic resistance to breakout or pull-out failure under combined tension and shear load	See Annex C 1
Edge distance and spacing	See Annex C 1
Durability	Corrosion Resistance Class (CRC) III in accordance with EN 1993-1-4:2015
Characteristic resistance to steel failure under tension and shear loads	See Annex C 1

#### 3.2 Safety in case of fire (BWR 2)

Essential characteristic	Performance
Reaction to fire	Class A1

English translation prepared by DIBt

**4 Assessment and verification of constancy of performance (AVCP) system applied, with reference to its legal base**

In accordance with EAD No. 330030-00-0601 the applicable European legal act is: [97/161/EG].  
The system to be applied is: 2+

**5 Technical details necessary for the implementation of the AVCP system, as provided for in the applicable European Assessment Document**

Technical details necessary for the implementation of the AVCP system are laid down in the control plan deposited with Deutsches Institut für Bautechnik.

Issued in Berlin on 22 September 2023 by Deutsches Institut für Bautechnik

Dipl.-Ing. Beatrix Wittstock  
Head of Section

*beglaubigt:*  
Aksünger

**Installed fastener**

**Figure A1:**

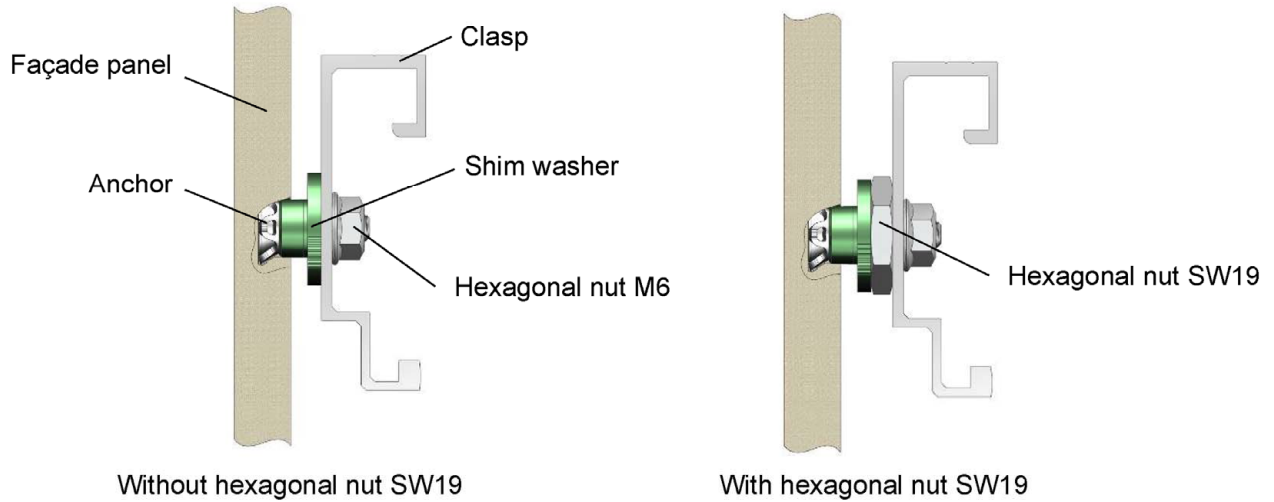

**Example of façade panel on substructure**

**Figure A2:**

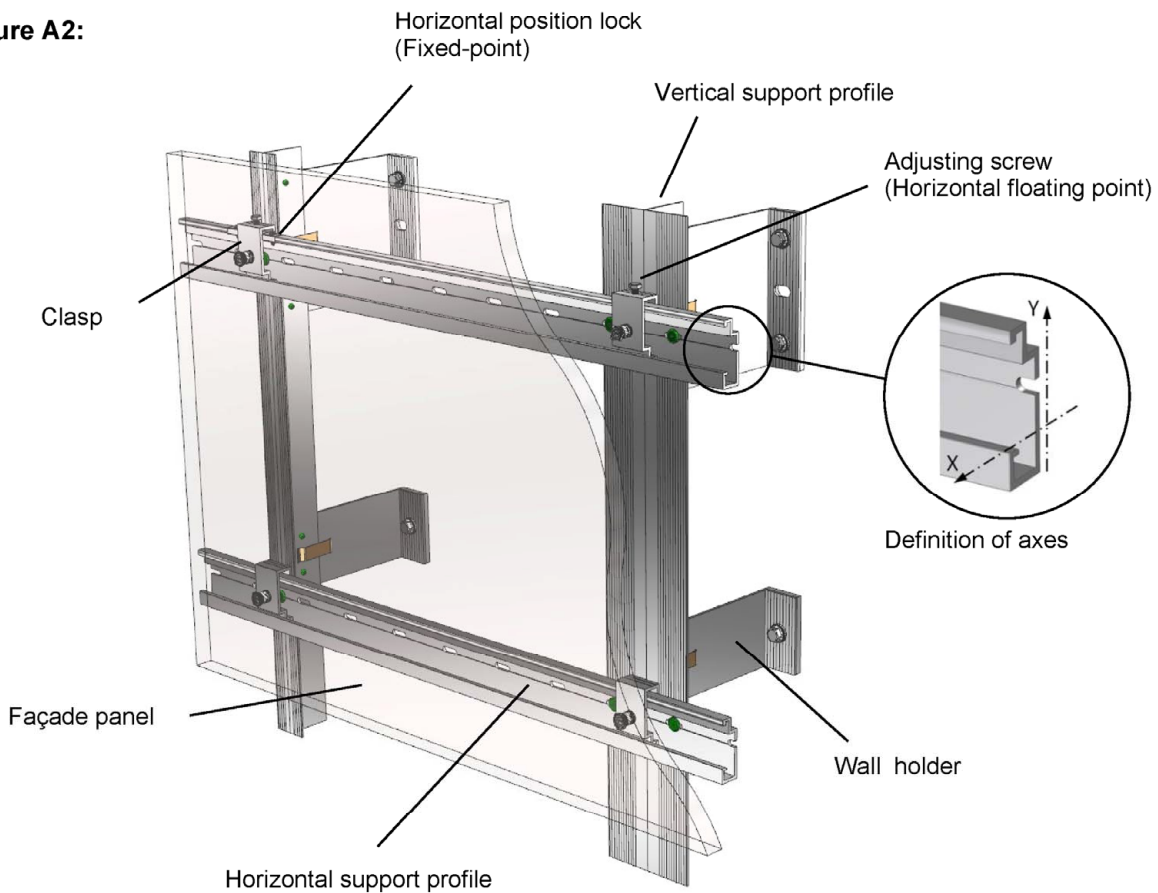

**fischer Zykon Panel anchor FZP II T for "LAMINAM ceramic"**

**Product description**  
Installed anchoring and fixing example

**Annex A 1**

### Type of anchor

#### Anchor with external thread M6

Figure A3:

Without hexagonal nut

With hexagonal nut

Undercut anchor  
FZP II - T

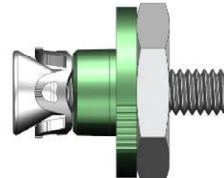
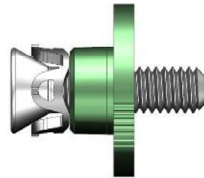

### Type of mounting

Figure A4:

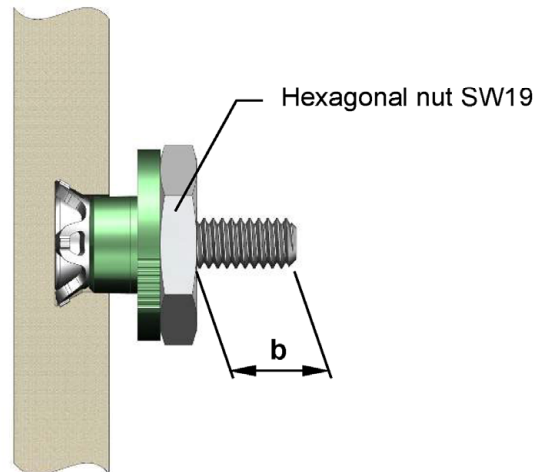
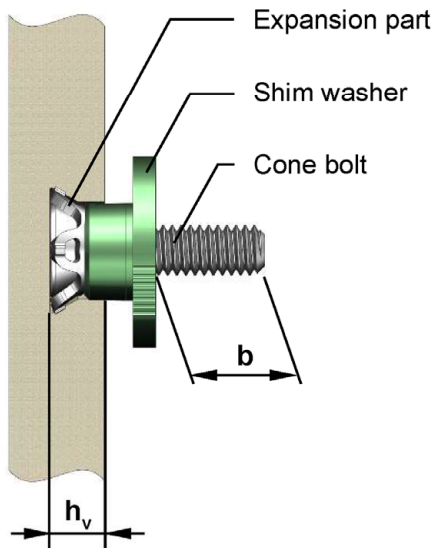

### Designation system

FZP II 11 x 10 M6 / T / 9 PA

- Shim washer made of polyamide (Al = with aluminum hex nut)
- Free thread length **b** after mounting
- Thin materials
- Thread diameter
- Maximum Drill hole depth  $h_v$  (Laminam  $h_v = h - h_r$ )
- $\varnothing$  Cylindrical drill hole  $d_0$
- Fischer Zykon (Cylindrical conical) Panel anchor II

fischer Zykon Panel anchor FZP II T for "LAMINAM ceramic"

#### Product description

Type of anchor, built-in state and designation system

Annex A 2

### Anchor parts and materials

#### Cone bolt external thread M6 (Optional with UNC thread)

Figure A5:

Material identification

Optional:

Anti rotation lock, e.g.

Nose or profiling on the cone or the front

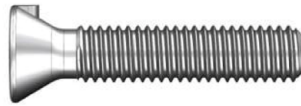

Optional:

Identifying mark, drive, e.g. Slot;

polygonal (Outside; inside);

spanner flats

#### Expansion part

For cone bolts with external thread M6

Figure A6:



#### Shim washer

For cone bolts with external thread M6

Figure A7:

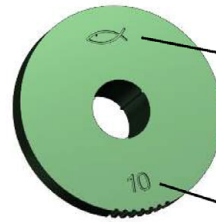
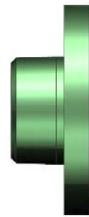

Identifying mark of producer

Maximum drill hole depth  $h_v$

#### Hexagonal nut

For cone bolts with external thread M6

Figure A8:



Identifying mark of producer

Marking: Al = Aluminum

Optional: R = stainless steel

Table A1: Materials of anchor parts

Anchor parts	Material
Cone bolt	Stainless steel, EN 10088 :2014
Expansion part	Stainless steel, EN 10088 :2014
Shim washer	Polyamide 6.6
Hexagonal nut	Aluminum, EN 755:2016 Stainless steel, EN 10088 :2014

fischer Zykon Panel anchor FZP II T for "LAMINAM ceramic"

Product description  
Anchor parts and materials

Annex A 3

### Specifications of intended use

#### Anchorage subject to:

- Static and quasi-static loads.

#### Base materials:

- The Laminam façade panels shall be in accordance with EN 14411:2016 "Ceramic tiles – definition, classification, characteristics, assessment and verification of constancy of performance and marking".  
The Laminam façade panels have to meet the requirements of group BI<sub>a</sub> according to EN 14411:2016.
- The characteristic values of the façade panels correspond Table B1.

**Table B1: Characteristic values of façade panels – geometrical and physical properties**

Trade name			Laminam 12+
Country of origin			Italy
Maximum panel size	L x H or H x L	[mm]	1620 x 3240
Nominal panel thickness	$h_{nom} =$	[mm]	12,5
Panel thickness (minimum)	$h_{min} =$	[mm]	11,8
Panel thickness (maximum)	$h_{max} =$	[mm]	12,6
Minimum operating thickness of the stand-off mechanism		[mm]	10,5
Maximum operating thickness of the stand-off mechanism		[mm]	12,6
Dead load	$g_k =$	[Kg/m <sup>2</sup> ]	30
Density – dry <sup>1)</sup>	$\rho \geq$	[g/cm <sup>3</sup> ]	> 2,2
Modulus of elastic	$E_{mean} =$	[N/mm <sup>2</sup> ]	50.000
Poisson ratio	$\nu =$	[-]	0,21
Coefficient of thermal expansion	$\alpha_T =$	[10 <sup>-6</sup> K <sup>-1</sup> ]	6,6
Characteristic bending strength	$\sigma_{5\%} =$	[N/mm <sup>2</sup> ]	39,9

<sup>1)</sup> In absence of other national regulations

#### Use condition:

- According to the corrosion resistance class (CRC) according to EN 1993-1-4:2015 (ETA Section 3.1)

**fischer Zykon Panel anchor FZP II T for "LAMINAM ceramic"**

**Intended use**  
Specifications

**Annex B 1**



**Design:**

- The design of anchorages under static and quasistatic load is carried out in accordance with the specifications of the façade panel manufacturer.
- The façade panels, their fixings as well as the substructure including its connection to wall brackets and their connection to the construction works are designed for the respective case of application under the responsibility of an engineer skilled in the field of façade construction.
- Verifiable calculation notes and drawings shall be prepared taking account of the loads to be anchored, the nature and strength of the base materials and the dimensions of the anchorage members as well as of the relevant tolerances. The position of the anchor is indicated on the design drawings.
- Each façade panel is fixed with at least four anchors in a rectangular arrangement via single clasps or panel support profiles on the substructure. For small panels or small fitted pieces, differential or fill- in pieces the number and position of the anchors shall be chosen constructively.
- Edge distance and spacing shall be observed. For small panels, differential and fitted pieces, the edge and axial spacing shall be chosen constructively.
- The substructure is constructed such that the façade panels are fixed technically strain-free via sliding points (loose bearings) and one fixed point (fixed bearing). The fixed point may be placed at the panel edge or in the panel field.
- Two fixing points of the façade panel are designed such that they are able to carry the dead load of the façade panel.
- When using clasps on horizontal support profiles, the horizontal fixing points of a facade panel at the same height must each be fixed to the same support profile.
- The permissible clasp torsion under service load is 2°.

**Installation:**

- The drillings are done at the factory or on site under workshop conditions; when making drillings on site the execution is supervised by the responsible project supervisor or a skilled representative of the project supervisor.
- Making of the undercut drilling is done with a special drill bit or a special CNC drill bit according to Annex B 4 and a special drilling device in accordance with the information deposited with Deutsches Institut für Bautechnik (DIBt).
- The drilling residues are removed from the drill hole.
- In case of aborted hole: new drilling at a minimum distance, of 15 mm away from the aborted hole.
- The geometry of the drill hole is checked at least on 5 % of all drillings. Check also when using a new drill bit or the operator changes. The following dimensions shall be checked and documented according to manufacturer's information and testing instructions by means of a control aids according to Annex B 5, Figure B5, B6 and B7.
  - Diameter of the cylindrical drill hole.
  - Diameter of the undercut.
  - Remaining panel thickness (drill hole depth and panel thickness respectively).
- If the tolerance given in Annex B 4, Table B2 is exceeded, the geometry of the drill hole shall be checked on 25 % of the drillings performed. No further drill hole should exceed the tolerances otherwise all drill holes have to be controlled. Drill holes falling below or exceeding the tolerances shall be rejected.
 

Note: Checking the geometry of drill hole on 5 % of all drillings means that on one of 5 panels (this corresponds to 20 drillings for panels with 4 undercut anchors) one drilling shall be checked. If the tolerances given in Annex B 4, Table B2 are exceeded, the control shall be increased to 25 % of the drillings, i.e. one drilling shall be checked on all the 5 panels.

<b>fischer Zykon Panel anchor FZP II T for "LAMINAM ceramic"</b>	<b>Annex B 2</b>
<b>Intended use Specifications</b>	

- The anchors are installed in a deformation controlled manner. For this purpose suitable installation tools per Annex B 5, Figure B4 shall be used. The anchor is set correctly if, bolt projection "b" as per Annex A 2, Figure B4 or Annex B 6, Illustration 5.1 and 6 is observed. The dimension "b" is indicated in the anchor designation.
- During transport and storage on site the façade panels are protected from damages; the façade panels are not to be hung up jerkily (if need be lifters shall be used for hanging up the façade panels); façade panels and reveal panels respectively with incipient cracks are not be installed.
- The façade panels are arranged in a "reclined" or "upright" position.
- The façade are installed by skilled specialists and the laying instructions of the manufacturer shall be paid attention to.
- The façade panels must not be used for the transmission of impact loads and for the protection against falling.
- Overhead installation is allowed

**Figure B1: Definition of edge distance and anchor spacing**

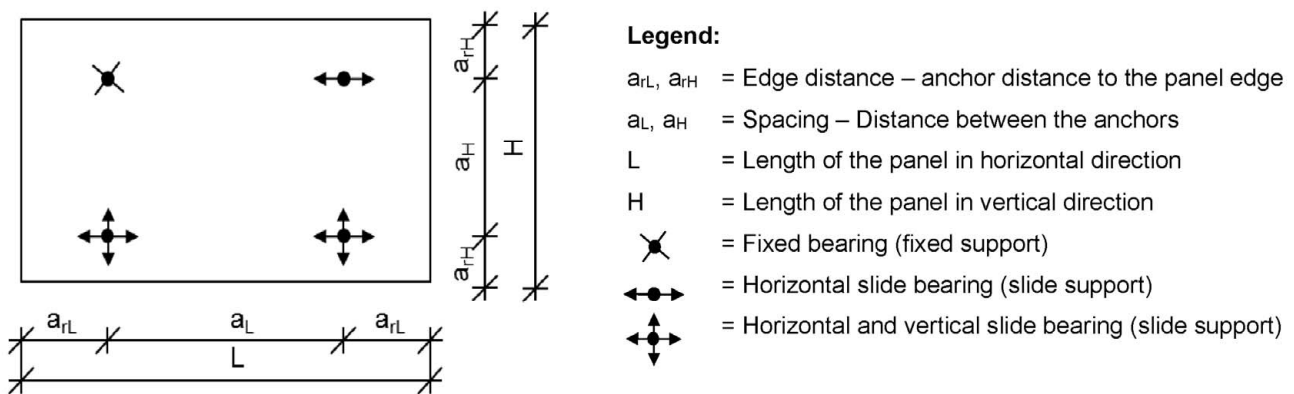

**fischer Zykon Panel anchor FZP II T for "LAMINAM ceramic"**

**Intended use**  
Installation

**Annex B 3**

**Drill hole geometry**  
**Figure B2:**

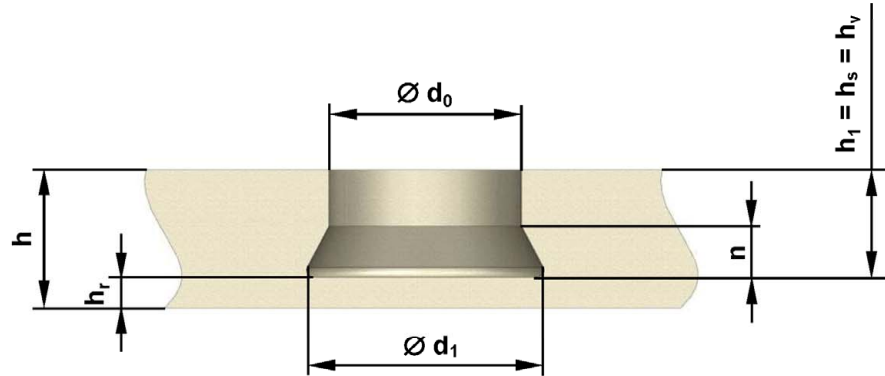

**Drill bits**  
**Figure B3:**

Examples:



**Table B2: Drill hole dimensions [mm]**

$\varnothing d_0$	$\varnothing d_1$	$h_r$ <sup>1)</sup>	n	$h_v$ <sup>2)</sup>	h
11,2 ± 0,2	13,5 ± 0,3	≥ 4,5	≈ 4	$h - h_r \geq 6$	≥ 10,5

1) Residual panel thickness is a mandatory dimension

2) The value for the anchorage depth  $h_v$  results from panel thickness  $h$  minus residual panel thickness  $h_r$

**fischer Zykon Panel anchor FZP II T for "LAMINAM ceramic"**

**Intended use**  
Drill hole geometry, drill bit and drill hole parameters

**Annex B 4**

**Setting tools**

**Figure B4:**



Manual setting tool SGT



Cordless screwdriver  
with setting tool e.g. SGA  
or screw socket

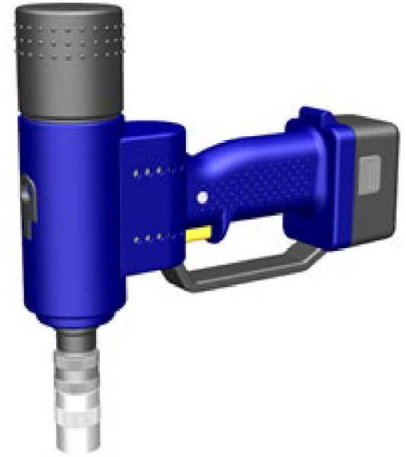

Battery-setting tool SGB

**Means for undercut control  $\varnothing d_1$**

**Figure B5:**



STU (Internal quick test)

**Volume gauge**

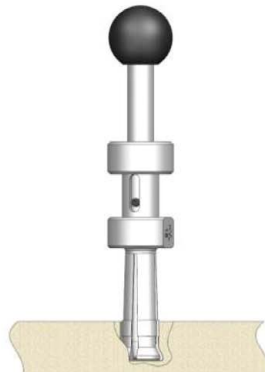

HVL-T (Undercut minimum volume gauge)

**Figure B6:**

**Go / noGo gauge for checking cylindrical drill hole diameter  $d_0$**

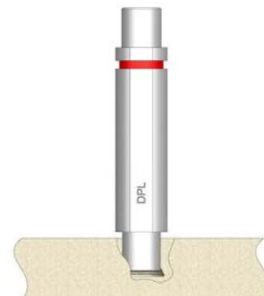

DPL-T (Diameter gauge)

**Means for measuring drill hole depth  $h_1$  and drill hole diameter  $d_0$**

**Figure B7:**

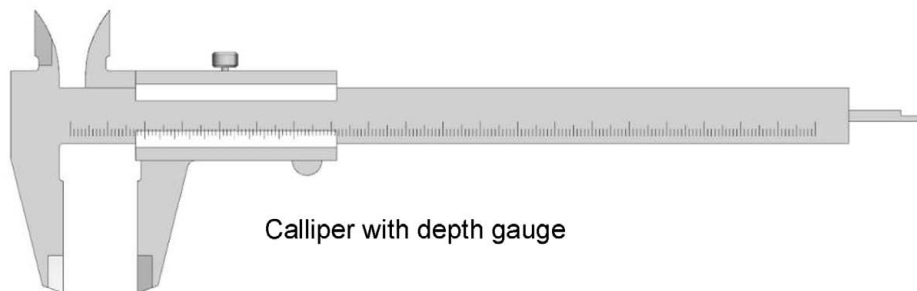

Calliper with depth gauge

**fischer Zykon Panel anchor FZP II T for "LAMINAM ceramic"**

**Intended use**  
Setting devices and testing equipment

**Annex B 5**

### Installation instructions

Example: Anchor installation with SGA

1.)



2.)

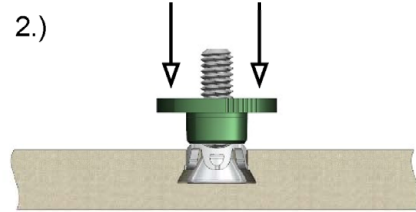

3.)

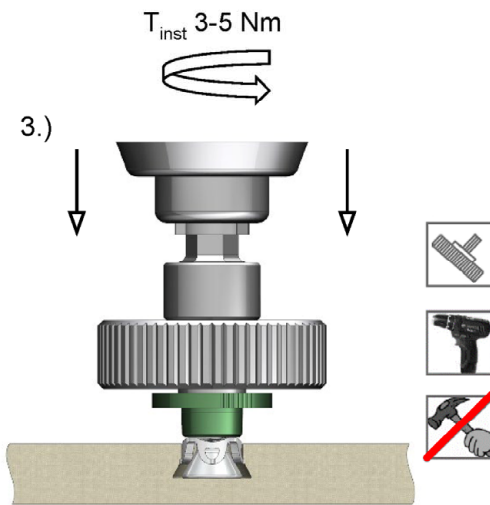

4.)

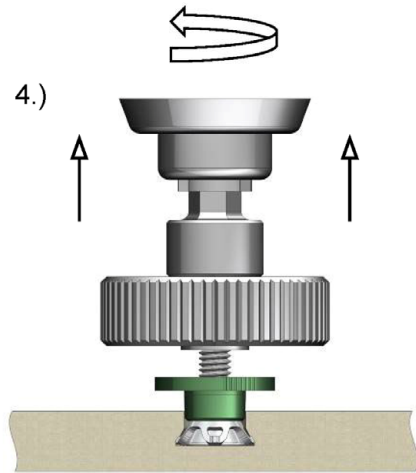

5.1.)

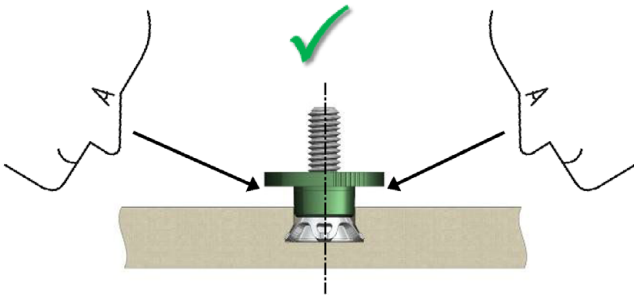

5.2.)

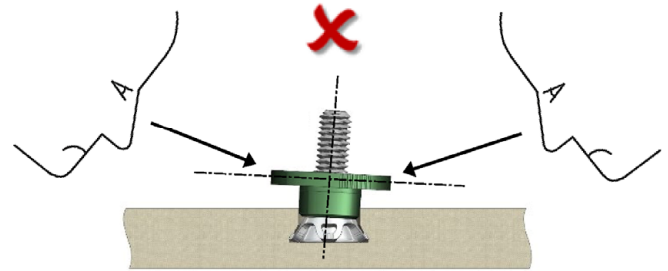

6.)

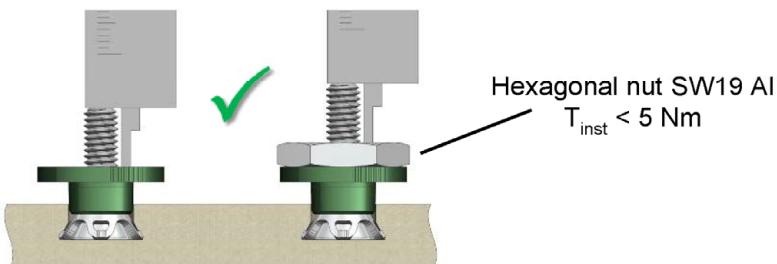

fischer Zykron Panel anchor FZP II T for "LAMINAM ceramic"

Intended use  
Installation instructions

Annex B 6

**Table C1: Characteristic values for anchor design**

Anchor type			FZP II 11x10 M6/T/9 PA		
Façade panel			Laminam 12+		
Nominal panel thickness	$h_{nom} =$	[mm]	12,5		
Residual panel thickness	$h_r =$	[mm]	$\geq 4,5$		
Embedment depth <sup>1)</sup>	$h_v =$	[mm]	$\geq 6$		
Anchor spacing	$a_{max} =$	[mm]	750		
Edge distance	$a_{r\ min} =$	[mm]	$\geq 100$	$\geq 50$	
Characteristic resistance <sup>3)</sup>	Tension load	$N_{Rk} =$	[kN]	1,74	1,53
	Shear load	$V_{Rk} =$	[kN]	3,41	3,04
Trilinear limit	Interaction	$X =$	[-]	1,2	
Partial safety factor <sup>2)</sup>		$\gamma_M =$	[-]	1,8	

- 1) For the application of FZP II in Laminam 12+ the following applies:  
Anchorage depth  $h_v =$  panel thickness  $h$  - residual panel thickness  $h_r$  (see Annex B4)
- 2) In absence of national regulations
- 3) The characteristic resistance values were obtained considering  $h_v = 6$  mm

**Table C2: Characteristic resistance for steel failure**

Type of Anchor			FZP II 11 M6/T	
Characteristic resistance under tension load <sup>1)</sup>	$N_{Rk,s} =$	[kN]	11,10	
Partial safety factor <sup>2)</sup>	$\gamma_{Ms} =$	[-]	1,89	
Characteristic resistance under shear load <sup>1)</sup>	$V_{Rk,s} =$	[kN]	5,53	
Partial safety factor <sup>2)</sup>	$\gamma_{Ms} =$	[-]	1,57	

- 1) Without strain hardening and minimum tensile strength of 550 N/mm<sup>2</sup>
- 2) In absence of national regulations

**fischer Zykon Panel anchor FZP II T for "LAMINAM ceramic"**

**Performances**  
Characteristic values for anchor design

**Annex C 1**