



ETA-Danmark A/S
Göteborg Plads 1
DK-2150 Nordhavn
Tel. +45 72 24 59 00
Internet www.etadanmark.dk

Authorised and notified
according to Article 29 of the
Regulation (EU)
No 305/2011 of the European
Parliament and of the Council
of 9 March 2011

MEMBER OF EOTA



European Technical Assessment ETA-20/1102 of 2020/12/11

I General Part

Technical Assessment Body issuing the ETA and designated according to Article 29 of the Regulation (EU) No 305/2011: ETA-Danmark A/S

Trade name of the construction product:

fischer FFRS Fire Rated Silicone

Product family to which the above construction product belongs:

Fire Stopping, Fire Sealing & Fire Protective Products.
Fire Retardant Products

Manufacturer:

fischerwerke GmbH & Co. KG
Klaus-Fischer-Straße 1
72178 Waldachtal
Germany

Manufacturing plant:

E/089

This European Technical Assessment contains:

17 pages including 2 annexes which form an integral part of the document

This European Technical Assessment is issued in accordance with Regulation (EU) No 305/2011, on the basis of:

EAD 350141-00-1106 Linear Joint and Gap Seals, Issued September 2017

This version replaces:

-

Translations of this European Technical Assessment in other languages shall fully correspond to the original issued document and should be identified as such.

Communication of this European Technical Assessment, including transmission by electronic means, shall be in full [except the confidential Annex(es) referred to above]. However, partial reproduction may be made with the written consent of the issuing Technical Assessment Body. Any partial reproduction has to be identified as such.

1 Technical Description of the Product

- 1) fischer FFRS Fire Rated Silicone is a silicone-based sealant used to form linear gap seals where gaps are present in floor and wall constructions.
- 2) The fischer FFRS Fire Rated Silicone is supplied in liquid form contained within 31 0ml & 83 0ml cartridges, 600 ml sausages and 200 litre drums.
- 3) PE backing rod, reference fischerwerke GmbH & Co.KG PE (RtF class F) is utilised as a depth gauge.

2 Specification of the intended use(s) in accordance with the applicable European Assessment Document (hereinafter EAD)

The intended use of fischer FFRS Fire Rated Silicone is to reinstate the fire resistance performance of gaps in and joints between joints in rigid floor constructions.

The specific elements of construction that the fischer FFRS Fire Rated Silicone may be used to provide a gap or joint seal in, are as follows:

Rigid Floor s:	The floor must have a minimum thickness of 150 mm and comprise concrete, aerated concrete or masonry, with a minimum density of 650 kg/m ³ .
Rigid walls :	The wall must have a minimum thickness of 150 mm and comprise concrete, aerated concrete or masonry, with a minimum density of 650 kg/m ³ .

The supporting construction must be classified in accordance with EN 13501-2 for the required fire resistance period.

- 4) The fischer FFRS Fire Rated Silicone may be used to provide a linear joint or gap seal with specific supporting constructions and substrates (for details see Annex B).
- 5) The maximum permitted joint/gap width for fischer FFRS Fire Rated Silicone is 60 mm.
- 6) The maximum movement capability of fischer FFRS Fire Rated Silicone is $\leq 7.5\%$
- 7) The provisions made in this European Technical Assessment are based on an assumed working life of the fischer FFRS Fire Rated Silicone of 10 years, The indications given on the working life cannot be interpreted as a guarantee given by the producer or the Technical Assessment Body, but are to be regarded only as a means for choosing the right products in relation to the expected economically reasonable working life of the works.

Use Category

Type X: Intended for use in conditions exposed to weathering.

3 Performance of The Product And References To The Methods Used For Its Assessment

BWR	Characteristic	Assessment of characteristic
2	Safety in case of fire	
	Reaction to fire	See Clause 1.1
	Resistance to fire	See clause 1.2
3	Hygiene, Health and the Environment	
	Dangerous substances	See clause 2.1
4	Safety and accessibility in use	
	Durability and serviceability	See clause 3.1

3.1 Safety in case of fire

3.1.1 Reaction to fire

fischer FFRS Fire Rated Silicone is classified 'E' in accordance with EN 13501-1.

3.1.2 Resistance to fire

fischer FFRS Fire Rated Silicone has been tested in accordance with BS EN 1366-4: 2006 based upon the test results and the field of direct application specified within EN 1366-4: 2006, the system Fischer FFRS Fire Rated Silicone has been classified in accordance with EN 13501-2, as given in Annex C:

The seals may only be used in the elements of construction described in Annex C and against the substrates described in Annex C.

Provisions shall be taken such that floor joint seals cannot be stepped on e.g. by covering with wire mesh or floor finishes.

3.2 Hygiene, Health and the environment.

3.2.1. Content and release of Dangerous Substances

The applicant has submitted a written declaration that the product and/or constituents of the product contains no substances which have been classified as dangerous according to Directive 67/548/EEC and Regulation (EC) No. 1272/2008 and listed in the 'indicative list on dangerous substances' of the EGDS – taking into account the installation conditions of the construction product and the release scenarios resulting from there.

In addition to the specific clauses relating to dangerous substances contained in this European Technical Assessment, there may be other requirements applicable to the products falling within its scope (e.g. transposed European legislation and national laws, regulations and administrative provisions). In order to meet the provisions of the Construction Products Regulation, these requirements need also to be complied with, when and where they apply.

The use category of fischer FFRS Fire Rated Silicone in relation to BWR 3 (Hygiene, health and environment) is IA1, S/W3

3.3 Safety and accessibility in use

3.3.1 Durability

fischer FFRS Fire Rated Silicone has been tested in accordance with EOTA Technical Report - TR024 – Edition November 2006, for the type X use category specified in EAD 351141-00-1106 Linear Joint and Gap Seals, and the results of the tests have demonstrated suitability for linear joint seals intended for use in conditions exposed to weathering.

4 Assessment and verification of constancy of performance (hereinafter AVCP) system applied, with reference to its legal base

According to the decision 1999/454/EC of the European Commission the system of assessment and verification of constancy of performance (see Annex V to the Regulation (EU) No 305/2011) given in the following table apply:

Products	Intended use/s	AVCP System
Fire stopping and fire sealing products	For fire compartmentation and/or fire protection or fire performance	System 1

5 Technical details necessary for the implementation of the AVCP system, as provided for in the applicable EAD

Technical details necessary for the implementation of the AVCP system are laid down in the control plan deposited at ETA-Danmark A/S prior to CE marking

Issued in Copenhagen on 2020-12-11 by

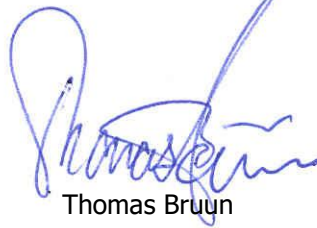

Thomas Bruun

Managing Director, ETA-Danmark

Annex A

Reference Documents

EN 13501-1	Fire classification of construction products and building elements – Part 1: Classification using test data from reaction to fire tests
EN 13501-2	Fire classification of construction products and building elements – Part 2: Classification using test data from fire resistance tests
EOTA TR 024	Characterisation, Aspects of Durability and Factory Production Control for Reactive Materials, Components and Products

Annex B

Resistance to Fire Classification of fischer FFRS Fire Rated Silicone

B.1 Rigid floor constructions according to 2.2.1 with thickness of minimum 150 mm

B.1.1 Masonry to Steel Unexposed Face

Construction details:

1. fischer FFRS Fire Rated Silicone
2. Rockwool min. 50 mm (45 kg/m³)
3. Steel Substrate 8 mm thick

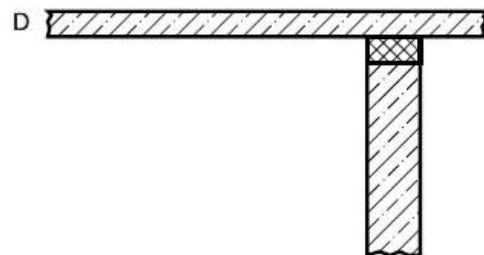
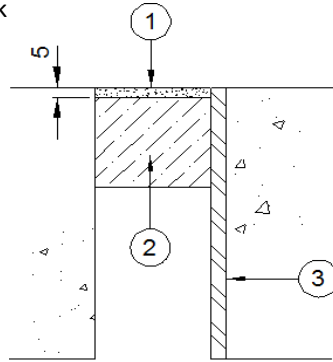

Key



joint seal



wall or floor – section

A tested linear joint in a horizontal test construction.

D direct field of application according to EN 1366-4:2006 Table 1 and figure 12: horizontal wall joint abutting a floor, ceiling or roof.

B.1.1.1

fischer FFRS Fire Rated Silicone Linear Joint Seals in Rigid Floors 150 mm thick (min.)	
Depth Sealant	Classification
5mm	E240 EI30 – H – X – F – W 00-60

B2.1 Masonry to Steel Exposed Face

Construction details:

1. fischer FFRS Fire Rated Silicone
2. Rockwool min. 50 mm (45 kg/m³)
3. Steel Substrate 8 mm thick

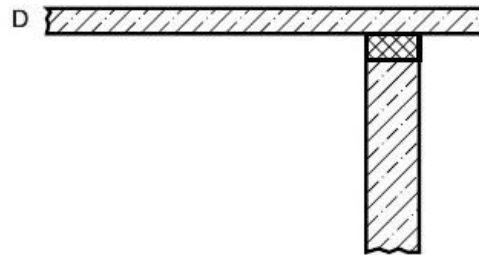
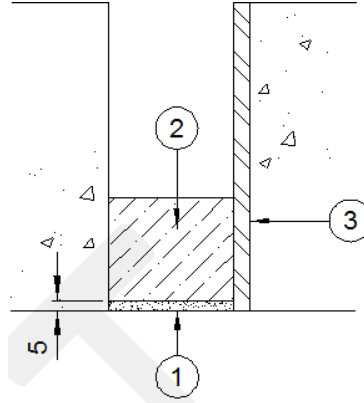

Key



joint seal



wall or floor – section

A tested linear joint in a horizontal test construction.

D direct field of application according to EN 1366-4:2006 Table 1 and figure 12:
horizontal wall joint abutting a floor, ceiling or roof.

B.2.1.1

fischer FFRS Fire Rated Silicone Linear Joint Seals in Rigid Floors 150 mm thick (min.)	
Depth Sealant	Classification
5mm	E240 EI60 – H – X – F – W 00-60

B 2.2.1 Masonry to Masonry Unexposed Face

Construction details:

1. fischer FFRS Fire Rated Silicone
2. Rockwool min. 50 mm (45 kg/m³)

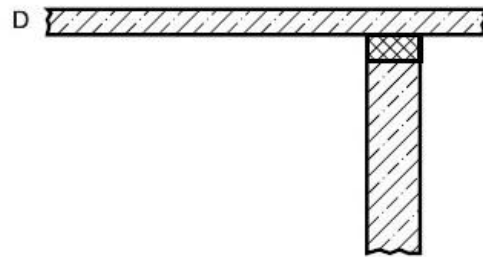
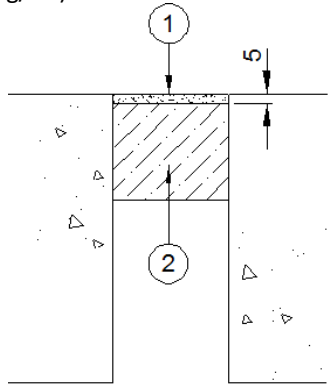

Key



joint seal



wall or floor – section

A tested linear joint in a horizontal test construction.

D direct field of application according to EN 1366-4:2006 Table 1 and figure 12:
horizontal wall joint abutting a floor, ceiling or roof.

B.2.2.2

fischer FFRS Fire Rated Silicone Linear Joint Seals in Rigid Floors 150 mm thick (min.)	
Depth Sealant	Classification
5mm	E240 EI60 – H – X – F – W 00-60

B.3 Masonry to Masonry Exposed Face

Construction details:

1. fischer FFRS Fire Rated Silicone
2. Rockwool min. 50 mm (45 kg/m³)

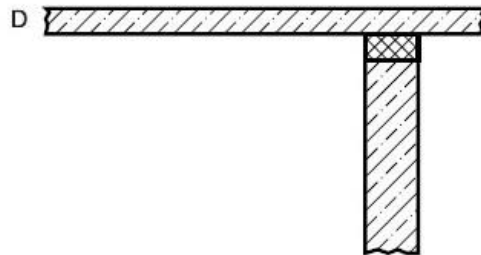
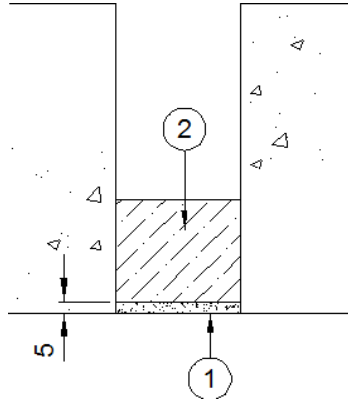

Key



joint seal



wall or floor – section

A tested linear joint in a horizontal test construction.

D direct field of application according to EN 1366-4:2006 Table 1 and figure 12:
horizontal wall joint abutting a floor, ceiling or roof.

B.3.1

fischer FFRS Fire Rated Silicone Linear Joint Seals in Rigid Floors 150 mm thick (min.)	
Depth Sealant	Classification
5mm	E120 EI60 – H – X – F – W 00-60

B3.1.1 Masonry to Masonry Unexposed Face

Construction details:

1. fischer FFRS Fire Rated Silicone
2. PE Backing Rod

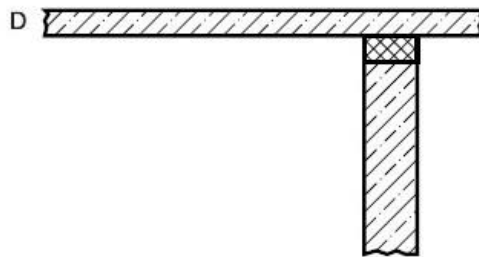
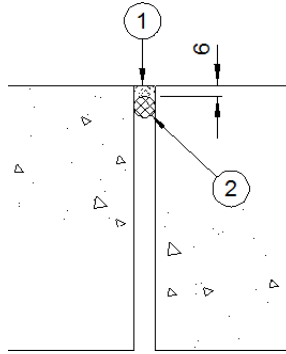

Key



joint seal



wall or floor – section

A tested linear joint in a horizontal test construction.

D direct field of application according to EN 1366-4:2006 Table 1 and figure 12:
horizontal wall joint abutting a floor, ceiling or roof.

B.3.1.2

fischer FFRS Fire Rated Silicone Linear Joint Seals in Rigid Floors 150 mm thick (min.)	
Depth Sealant	Classification
6mm	E240 EI120 – H – X – F – W 00-12

B 3.2.1 Masonry to Masonry Unexposed Face

Construction details:

1. fischer FFRS Fire Rated Silicone
2. PE Backing Rod

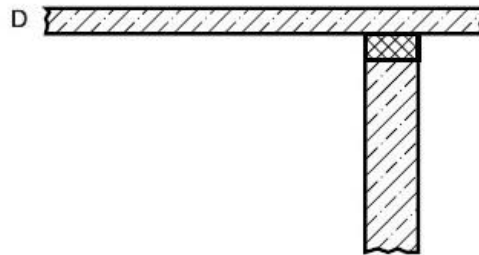
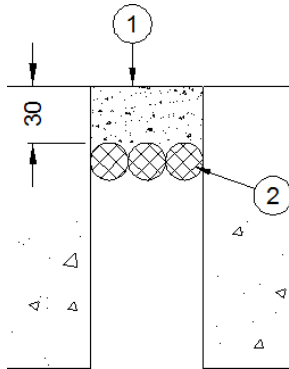

Key



joint seal



wall or floor – section

A tested linear joint in a horizontal test construction.

D direct field of application according to EN 1366-4:2006 Table 1 and figure 12:
horizontal wall joint abutting a floor, ceiling or roof.

B.3.2.2

fischer FFRS Fire Rated Silicone Linear Joint Seals in Rigid Floors 150 mm thick (min.)	
Depth Sealant	Classification
30mm	E240 EI90 – H – X – F – W 00-60

B.4 Rigid wall constructions according to 2.2.1 with thickness of minimum 150 mm

B.4.1 Masonry to Masonry Both Faces

Construction details:

1. fischer FFRS Fire Rated Silicone
2. Rockwool min. 50 mm (45 kg/m³)

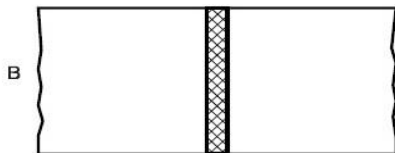
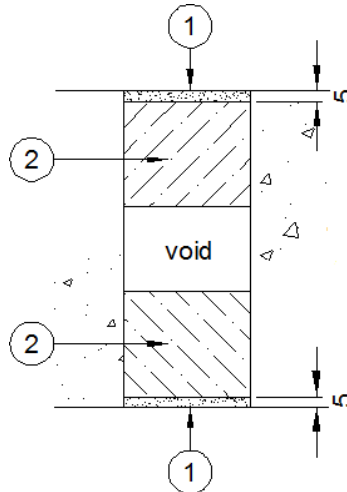

Key



joint seal



wall – front view

B tested vertical linear joint in a vertical test construction, and direct field of application according to EN 1366-4:2006 Table 1 and figure 12

B.4.1.1

fischer FFRS Fire Rated Silicone Linear Joint Seals in Rigid Walls 150 mm thick (min.)	
Depth Sealant	Classification
5mm	EI240 – V – X – F – W 00-60

B 4.1.2 Masonry to Masonry Both Faces

Construction details:

1. fischer FFRS Fire Rated Silicone
2. PE Backing Rod

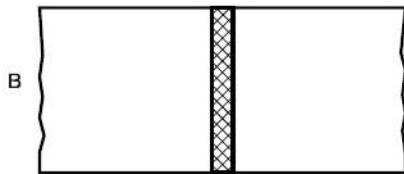
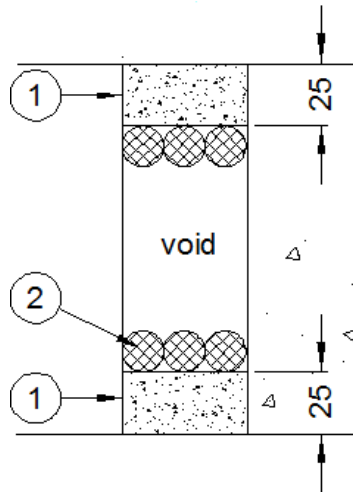

Key



joint seal



wall – front view

B tested vertical linear joint in a vertical test construction, and direct field of application according to EN 1366-4:2006 Table 1 and figure 12

B.4.2.1

fischer FFRS Fire Rated Silicone Linear Joint Seals in Rigid Walls 150 mm thick (min.)	
Depth Sealant	Classification
25mm	EI240 – V – X – F – W 00-50

B 4.2.2 Masonry to Steel Both Faces

Construction details:

1. fischer FFRS Fire Rated Silicone
2. Rockwool min. 50 mm (45 kg/m³)
3. Steel Substrate 8mm Thick

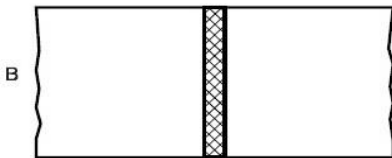
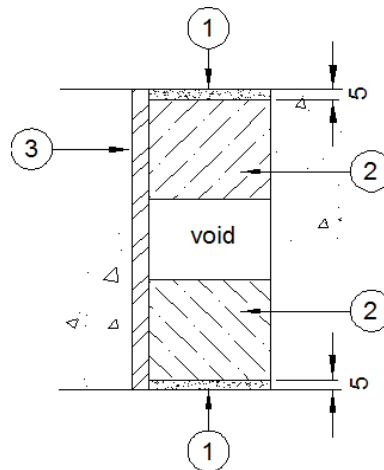

Key



joint seal



wall – front view

B tested vertical linear joint in a vertical test construction, and direct field of application according to EN 1366-4:2006 Table 1 and figure 12

B.4.2.3

fischer FFRS Fire Rated Silicone Linear Joint Seals in Rigid Walls 150 mm thick (min.)	
Depth Sealant	Classification
5mm	E240 EI60 – V – X – F – W 00-60

B.4.2.4 Masonry to Softwood Both Faces

Construction details:

1. fischer FFRS Fire Rated Silicone
2. Rockwool min. 50 mm (45 kg/m³)
3. Softwood

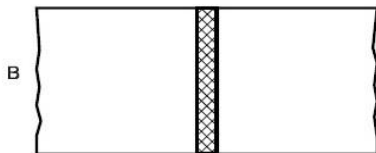
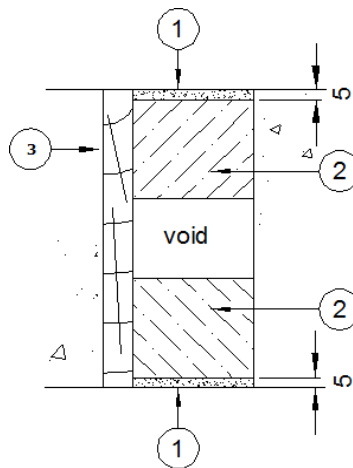

Key



joint seal



wall – front view

B tested vertical linear joint in a vertical test construction, and direct field of application according to EN 1366-4:2006 Table 1 and figure

B.4.2.5

fischer FFRS Fire Rated Silicone Linear Joint Seals in Rigid Walls 150 mm thick (min.)	
Depth Sealant	Classification
5mm	EI180 – V – X – F – W 00-60

B.4.2.6 Masonry to Hardwood Both Faces

Construction details:

1. fischer FFRS Fire Rated Silicone
2. Rockwool min. 50 mm (45 kg/m³)
3. Hardwood

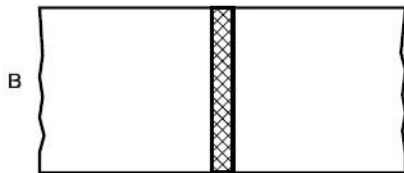
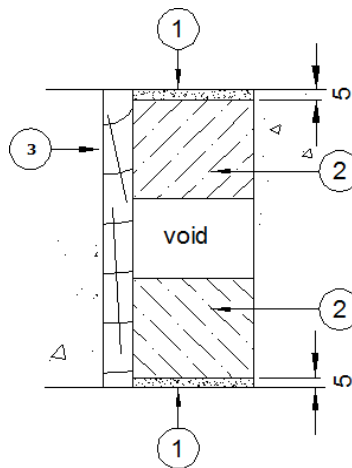

Key



joint seal



wall – front view

B tested vertical linear joint in a vertical test construction, and direct field of application according to EN 1366-4:2006 Table 1 and figure 12

B.4.2.7

fischer FFRS Fire Rated Silicone Linear Joint Seals in Rigid Walls 150 mm thick (min.)	
Depth Sealant	Classification
5mm	EI180 – V – X – F – W 00-60

B.5 Rigid wall constructions according to 2.2.1 with thickness of minimum 100 mm

B.5.1 Masonry to Plasterboard Both Faces

Construction details:

1. fischer FFRS Fire Rated Silicone
2. Rock fibre 45 kg/m³

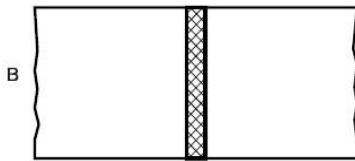
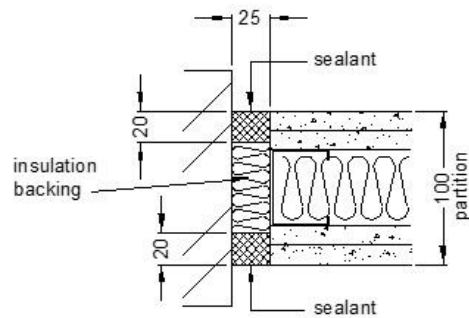

Key



joint seal



wall – front view

B tested vertical linear joint in a vertical test construction, and direct field of application according to EN 1366-4:2006 Table 1 and

B.5.1.1

fischer FFRS Fire Rated Silicone Linear Joint Seals in Rigid Walls 100 mm thick (min.)	
Depth Sealant	Classification
20mm	EI120 – V – X – F – W 00-25