



LEISTUNGSERKLÄRUNG



DoP: 0134

für fischer Betonschraube ULTRACUT FBS II A4 (Metalldübel zur Verwendung im Beton (hoch belastbar)) – DE

1. Eindeutiger Kenncode des Produkttyps: **DoP: 0134**
2. Verwendungszweck(e): **Nachträgliche Befestigung im gerissenen und ungerissenen Beton, siehe Anhang, insbesondere Anhänge B 1 bis B 4**
3. Hersteller: **fischerwerke GmbH & Co. KG, Klaus-Fischer-Straße 1, 72178 Waldachtal, Deutschland**
4. Bevollmächtigter: --
5. System(e) zur Bewertung und Überprüfung der Leistungsbeständigkeit: **1**
6. Europäisches Bewertungsdokument: **EAD 330232-00-0601**

Europäische Technische Bewertung: **ETA-17/0740; 2018-05-16**

Technische Bewertungsstelle: **ETA-Danmark A/S**

Notifizierte Stelle(n): **1343 – MPA Darmstadt**

7. Erklärte Leistung(en):

Mechanische Festigkeit und Standsicherheit (BWR 1)

- **Charakteristischer Widerstand für statische und quasi-statische Einwirkungen: Siehe Anhang, insbesondere Anhang C 1**
- **Charakteristischer Widerstand für die seismische Leistungskategorien C1 und C2: Siehe Anhang, insbesondere Anhang C 2**
- **Verschiebungen für statische und quasi-statische Einwirkungen: Siehe Anhang, insbesondere Anhang C 4**
- **Verschiebungen für seismische Einwirkungen: Siehe Anhang, insbesondere Anhang C 4**

Brandschutz (BWR 2)

- **Brandverhalten: Der Dübel erfüllt die Anforderungen der Klasse A 1**
- **Charakteristischer Widerstand unter Brandbeanspruchung: Siehe Anhang, insbesondere Anhang C 3**

8. Angemessene Technische Dokumentation und/oder Spezifische Technische Dokumentation: ---

Die Leistung des vorstehenden Produkts entspricht der erklärten Leistung/den erklärten Leistungen. Für die Erstellung der Leistungserklärung im Einklang mit der Verordnung (EU) Nr. 305/2011 ist allein der obengenannte Hersteller verantwortlich.

Unterzeichnet für den Hersteller und im Namen des Herstellers von:

Andreas Bucher, Dipl.-Ing.

Wolfgang Hengesbach, Dipl.-Ing., Dipl.-Wirtsch.-Ing.

i.V. A. Bucher

i.V. W. Hengesbach

Tumlingen, 2018-05-23

- Diese Leistungserklärung wurde in verschiedenen Sprachversionen erstellt. Für den Fall unterschiedlicher Auslegung hat immer die englische Version Vorrang.
- Der Anhang enthält freiwillige und ergänzende Informationen in englischer Sprache. Diese gehen über die (sprachneutral angegebenen) gesetzlichen Anforderungen hinaus.



ETA-Danmark A/S
Göteborg Plads 1
DK-2150 Nordhavn
Tel. +45 72 24 59 00
Fax +45 72 24 59 04
Internet www.etadanmark.dk

Appendix 1 / 15

Authorised and notified according
to Article 29 of the Regulation (EU)
No 305/2011 of the European
Parliament and of the Council of
9 March 2011

MEMBER OF EOTA



European Technical Assessment ETA-17/0740 of 2018/05/16

I General Part

Technical Assessment Body issuing the ETA and designated according to Article 29 of the Regulation (EU) No. 305/2011: ETA-Danmark A/S

Trade name of the construction product:

fischer concrete screw ULTRACUT FBS II A4

Product family to which the above construction product belongs:

Mechanical fasteners for use in cracked and un-cracked concrete

Manufacturer:

fischerwerke GmbH & Co. KG
Klaus-Fischer-Straße 1
D-72178 Waldachtal

Manufacturing plant:

fischerwerke

This European Technical Assessment contains:

15 pages including 3 annexes which form an integral part of the document

This European Technical Assessment is issued in accordance with Regulation (EU) No. 305/2011, on the basis of:

EAD 330232-00-0601; Mechanical fasteners for use in concrete

This version replaces:

-

Translations of this European Technical Assessment in other languages shall fully correspond to the original issued document and should be identified as such.

Communication of this European Technical Assessment, including transmission by electronic means, shall be in full. However, partial reproduction may be made, with the written consent of the issuing Technical Assessment Body. Any partial reproduction has to be identified as such.

II SPECIFIC PART OF THE EUROPEAN TECHNICAL ASSESSMENT

1 Technical description of product and intended use

Technical description of the product

fischer concrete screw ULTRACUT FBS II A4 is a concrete screw made of stainless steel. The anchor is installed in a drilled hole and anchored by mechanical interlock.

An illustration of the product is given in Annex A.

The characteristic material values, dimensions and tolerances of the anchors not indicated in Annexes shall correspond to the respective values laid down in the technical documentation of this European Technical Assessment.

The anchors are intended to be used with embedment depth given in Annex B, Table B2.1. The intended use specifications of the product are detailed in the Annex B1.

2 Specification of the intended use in accordance with the applicable EAD

The performances given in Section 3 are only valid if the anchor is used in compliance with the specifications and conditions given in Annex B.

The provisions made in this European Technical Assessment are based on an assumed intended working life of the anchor of 50 years.

The indications given on the working life cannot be interpreted as a guarantee given by the producer or Assessment Body, but are to be regarded only as a means for choosing the right products in relation to the expected economically reasonable working life of the works.

3 Performance of the product and references to the methods used for its assessment

3.1 Characteristics of product

Mechanical resistance and stability (BWR 1):

The essential characteristics are detailed in the Annex C1, C2 and C4.

Safety in case of fire (BWR 2):

The essential characteristics are detailed in the Annex C3.

Other Basic Requirements are not relevant.

3.2 Methods of assessment

The assessment of fitness of the anchor for the intended use in relation to the requirements for mechanical resistance and stability and safety in use in the sense of the Basic Works Requirement 1 has been made in accordance with EAD 330232-00-0601; Mechanical fasteners for use in concrete.

4 Assessment and verification of constancy of performance (AVCP)

4.1 AVCP system

According to the decision 1996/582/EC of the European Commission, the system(s) of assessment and verification of constancy of performance (see Annex V to Regulation (EU) No. 305/2011) is 1.

5 Technical details necessary for the implementation of the AVCP system, as foreseen in the applicable EAD

Technical details necessary for the implementation of the AVCP system are laid down in the control plan deposited at ETA-Danmark prior to CE marking.

Issued in Copenhagen on 2018-05-16 by



Thomas Bruun
Managing Director, ETA-Danmark

Product in the installed condition

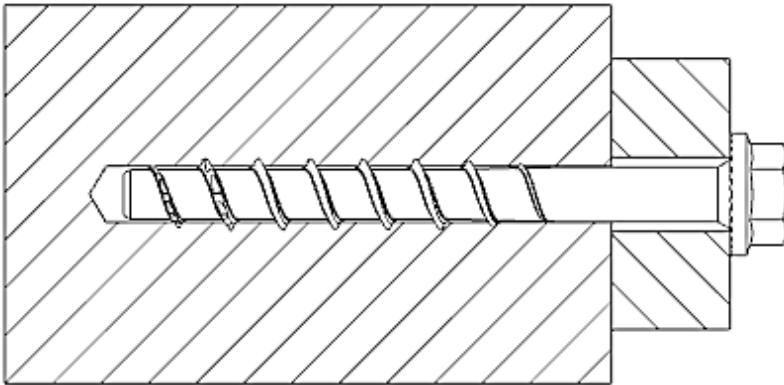

FBS II US A4 /
FBS II US TX A4

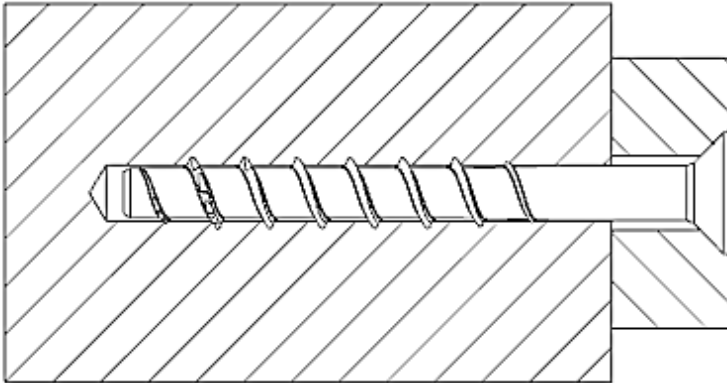

FBS II SK A4

fischer concrete screw ULTRACUT FBS II A4

Product description
Product in the installed condition

Annex A1
of European
Technical Assessment
ETA-17/0740

Table A2.1: Material and screw types

FBS II US A4 and FBS II SK A4		8	10	12	
Thread outer diameter	d_a	[mm]	10,3	12,5	14,6
Core diameter	d_k		7,5	9,4	11,1
Shaft diameter	d_s		8,0	9,9	11,7
Material		Tip: hardened steel; Shaft and Head: stainless steel			
Hexagon head with formed washer (US)					
Hexagon head with formed washer and TX-drive (US TX)					
Countersunk Head (SK)					

Head Marking

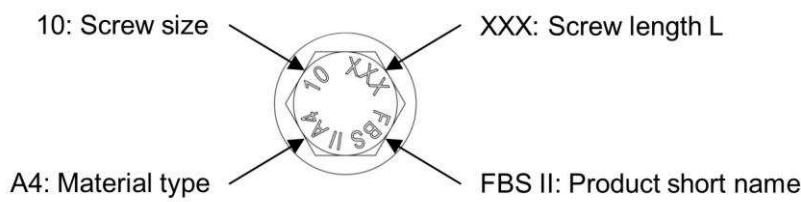

fischer concrete screw ULTRACUT FBS II A4	Annex A2 of European Technical Assessment ETA-17/0740
Product description Material and screw types	

Specification of intended use:

Size	FBS II A4		
	8	10	12
Static and quasi-static loads			
Cracked and uncracked concrete		✓	
Fire exposure			
Seismic performance category C1 and C2			

Base materials:

- Reinforced and unreinforced normal weight concrete according to EN 206:2000
- Strength classes C20/25 to C50/60 according to EN 206:2000
- Uncracked or cracked concrete

Use conditions (Environmental conditions):

- Structures subjected to dry internal conditions
- Structures subjected to external atmospheric exposure (including industrial and marine environment) and to permanently damp internal condition, if no particular aggressive conditions exist

Note: Particular aggressive conditions are e.g. permanent, alternating immersion in seawater or the splash zone of seawater, chloride atmosphere or indoor swimming pools or atmosphere with extreme chemical pollution (e.g. in desulphurization plants or road tunnels where deicing materials are used)

Design:

- Anchorages are to be designed under the responsibility of an engineer experienced in anchorages and concrete work.
- Verifiable calculation notes and drawings are to be prepared taking account of the loads to be anchored. The position of the screw is indicated on the design drawings (e.g. position of the screw relative to reinforcement or to supports, etc.).
- Design of fastenings according to FprEN 1992-4: 2016 and EOTA Technical Report TR 055
- Seismic design according EOTA Technical Report TR 049

Installation:

- Hammer drilling or diamond drilling or hollow drilling with functional suction according to Annex B4
- Screw installation carried out by appropriately qualified personnel and under the supervision of the person responsible for technical matters on site.
- In case of aborted hole: New hole must be drilled at a minimum distance of twice the depth of the aborted hole or closer, if the hole is filled with a high strength mortar and only if the hole is not in the direction of the oblique tensile or shear load.
- Adjustability according to Annex B3
- Cleaning of drill hole is not necessary when using a hollow drill with functional suction or:
 - If drilling vertically upwards
 - If drilling vertical downwards and the drill hole depth has been increased. We recommend to increase the drill depth with additional 3 d_o.
- After correct installation further turning of the screw head should not be possible.
- The head of the screw must be fully engaged on the fixture and show no signs of damage.
- For seismic performance category C2 applications: The gap between screw shaft and fixture must be filled with mortar; mortar compressive strength ≥ 50 N/mm².

fischer concrete screw ULTRACUT FBS II A4	Annex B1 of European Technical Assessment ETA-17/0740
Intended use Specification	

Table B2.1: Installation parameters

FBS II A4			8	10	12
Nominal embedment depth	h_{nom}		65	85	100
Nominal drill hole diameter	d_0		8	10	12
Cutting diameter of drill bits	$d_{cut} \leq$		8,45	10,45	12,50
Cutting diameter for diamond drillers	$d_{cut} \leq$	[mm]	8,10	10,30	12,30
Clearance hole diameter	d_f		10,6 – 12,0	12,8 – 14,0	14,8 – 16,0
Wrench size (US,S)	SW		13	15	17
TX-size	TX	-	40	50	-
Countersunk head diameter	d_h		18	21	-
Countersunk diameter in fixture	d_c		20	23	-
Drill hole depth ¹⁾	$h_1 \geq$		75	95	110
Drill hole depth ¹⁾ (with adjustable setting)	$h_1 \geq$	[mm]	85	105	120
Thickness of fixture	$t_{fix}^{3)} \geq$		0		
	$t_{fix} \leq$		L - h_{nom}		
Length of screw	$L_{min}^{3)} =$		65	85	100
	$L_{max} =$		415	435	450
Torque impact screw driver ²⁾	$T_{imp,max}$	[Nm]	450		650
Torque impact screw driver (with adjustable setting process) ²⁾	$T_{imp,max}$	[Nm]	300		450

1) Cleaning of drill hole is not necessary when using a hollow drill with functional suction or:
if drilling vertical upwards

If drilling vertical downwards and the drill hole depth has been increased. We recommend to increase the drill depth with additional $3 \times d_0$.

2) Installation with any torque impact screw driver up to the maximum mentioned torque moment ($T_{imp,max}$). Alternatively, all other tools without a mentioned torque moment are allowed (e.g. ratchet spanner). In any case it must be secured, that after installation the head of the screw must be tight down on the fixture. An easy further turning of the screw must not be possible and the head of the screw is not damaged. The torque moments $T_{imp,max}$ are not valid for manual installation (e.g. torque wrench).

3) For countersunk screws the height of the head must be added to t_{fix} and L_{min} and L_{max}

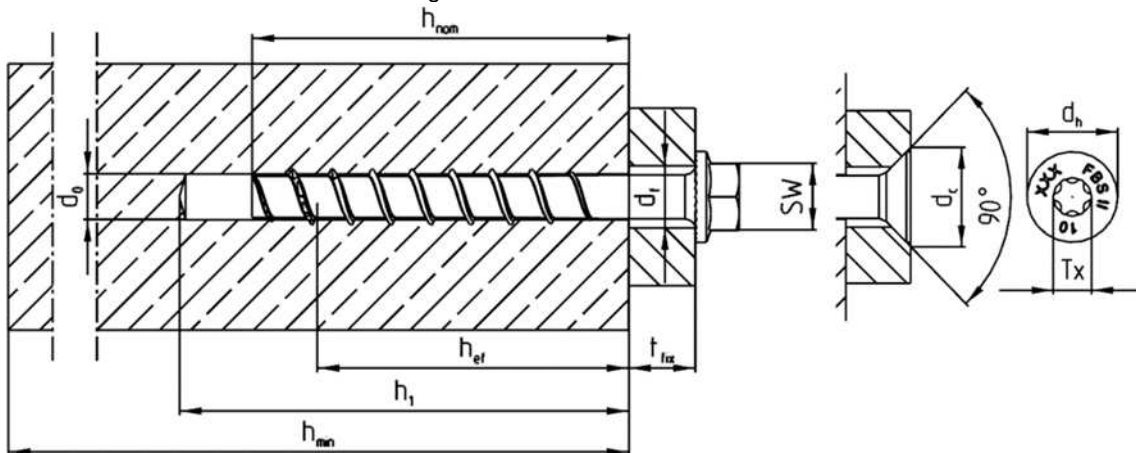

fischer concrete screw ULTRACUT FBS II A4

Intended use
Installation parameters

Annex B2
of European
Technical Assessment
ETA-17/0740

Adjustment

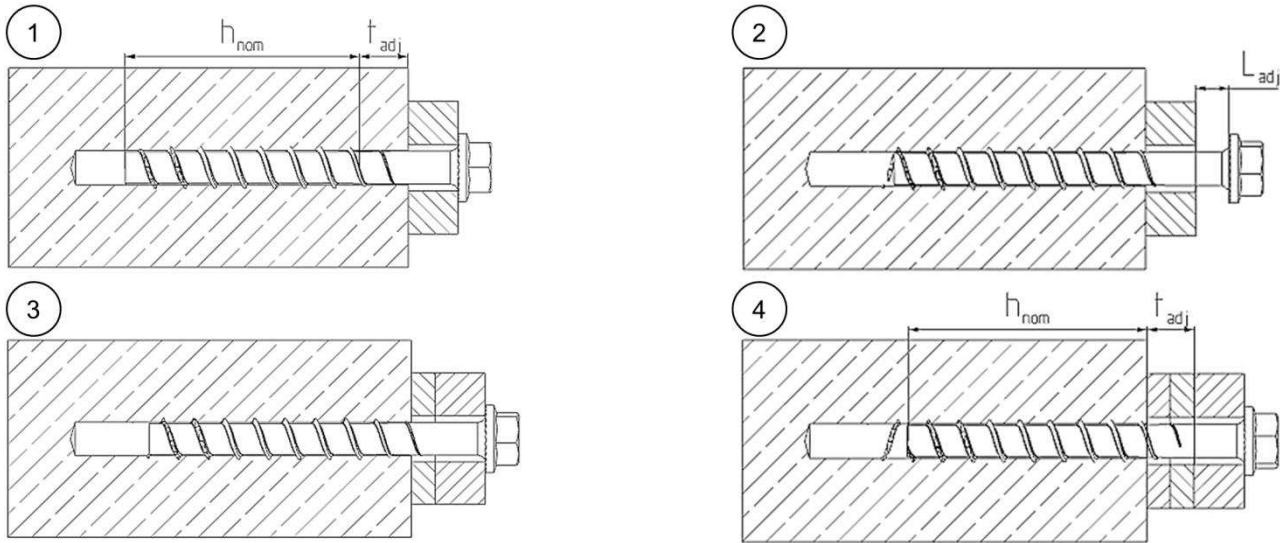

It is permissible to untighten the screw up to two times for adjustment purposes. Therefore the screw may be untightened to a maximum of $L_{adj} = 20$ mm to the surface of the initial fixture. The total permissible thickness of shims added during the adjustment process is $t_{adj} = 10$ mm.

Table B3.1: Minimum thickness of concrete members, minimum spacing and edge distance

FBS II A4			8	10	12
Nominal embedment depth	h_{nom}	[mm]	65	85	100
Minimum thickness of concrete member	h_{min}		120	140	150
Minimum spacing	s_{min}		35	40	50
Minimum edge distance	c_{min}		35	40	50

fischer concrete screw ULTRACUT FBS II A4

Intended use – Adjustment
Minimum thickness of members, minimum spacing and edge distance

Annex B3
of European
Technical Assessment
ETA-17/0740

Installation instruction	
Installation of fischer concrete screw ULTRACUT FBS II A4	
	<p>Drill the hole using hammer drill, hollow drill or diamond core drill.</p> <p>Drill hole diameter d_0 and drill hole depth h_1 according to table B2.1</p>
<p>a)</p>  <p>b)</p> 	<p>Option a) Clean the drill hole</p> <p>Option b) Cleaning of drill hole is not necessary when using a hollow drill with functional suction or:</p> <ul style="list-style-type: none"> - If drilling vertically upwards or - If drilling vertically downwards and the drill hole depth has been increased. We recommend to increase the drill hole depth additional 3 times d_0.
	<p>Installation with any torque impact screw driver up to the maximum mentioned torque moment ($T_{imp,max}$). Alternatively, all other tools without an indicated torque moment are allowed (e.g. ratchet spanner). The indicated torque moments for impact screw driver are therefore not decisive.</p>
	<p>After installation a further turning of the screw must not be possible. The head of the screw must be in contact with the fixture and is not damaged.</p>
<p>1.</p>  <p>2.</p>  <p>3.</p> 	<p>OPTIONAL:</p> <p>It is permissible to adjust the screw two times. Therefore, the screw may be untightened to a maximum of $L_{adj} = 20$ mm off the surface of the initial fixture. The total permissible thickness of shims added during the adjustment process is $t_{adj} = 10$ mm</p>
	<p>For seismic performance category C2 applications: The gap between screw shaft and fixture must be filled with mortar; mortar compressive strength ≥ 50 N/mm²</p>
<p>fischer concrete screw ULTRACUT FBS II A4</p>	<p>Annex B4 of European Technical Assessment ETA-17/0740</p>
<p>Installation Instructions</p>	

Table C1.1: Characteristic values for static and quasi-static action

FBS II A4			8	10	12	
Nominal embedment depth	h_{nom}	[mm]	65	85	100	
Steel failure for tension load and shear load						
Characteristic resistance	$N_{Rk,S}$	[kN]	27,8	43,8	67,7	
	$\gamma_{M,S,N}$	-	1,5			
	$V^0_{Rk,S}$	[kN]	27,8	36,6	45,8	
	$\gamma_{M,S,V}$	[-]	1,25			
	k_7		1,0			
	$M^0_{Rk,s}$	[Nm]	31,3	68,5	112,8	
Pullout failure						
Charact. resistance in concrete C20/25	Cracked	$N_{Rk,P}$	[kN]	9,0	16,0	-1)
	Uncracked	$N_{Rk,P}$	[kN]	14,0	-1)	-1)
Increasing factor concrete	C25/30	ψ_c	[-]	1,12		
	C30/37			1,22		
	C35/45			1,32		
	C40/50			1,41		
	C45/55			1,50		
	C50/60			1,58		
Robustness factor	γ_{inst}	[-]	1,0			
Concrete cone failure and splitting failure; concrete pryout failure						
Effective embedment depth	h_{ef}	[mm]	52	68	81	
Factor for	Cracked	$k_{Cr,N}$	[-]	7,7		
	Uncracked	$k_{Ucr,N}$		11,0		
Concrete cone failure	Edge distance	$C_{Cr,N}$	[mm]	1,5 h_{ef}		
	Spacing	$S_{Cr,N}$		3 h_{ef}		
Splitting failure	Cracked and Uncracked	$N^0_{Rk,Sp}$	[kN]	18,4	-1)	-1)
	Edge distance	$C_{Cr,sp}$	[mm]	1,5 h_{ef}		
	Spacing	$S_{Cr,sp}$		3 h_{ef}		
k-factor for pryout failure	k_8	[-]	1,0	2,0		
Robustness safety factor	γ_{inst}		1,0			
Concrete edge failure						
Effective length in concrete	$l_f = h_{nom}$	[mm]	65	85	100	
Nominal diameter of screw	d_{nom}	[mm]	8	10	12	

1) Pullout failure not decisive.

fischer concrete screw ULTRACUT FBS II A4

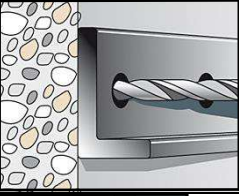
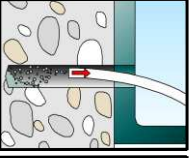
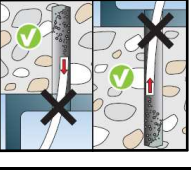
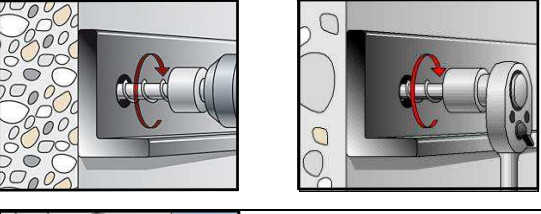
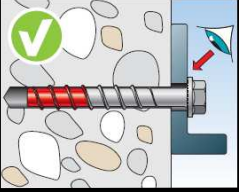
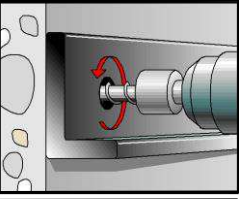
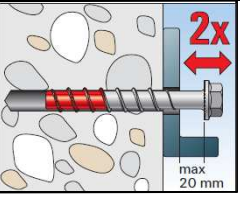
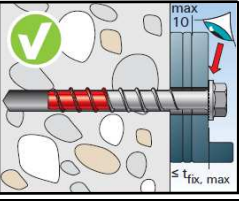
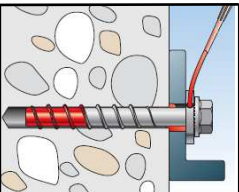
Characteristic values for static and quasi-static action

Annex C1
of European
Technical Assessment
ETA-17/0740

Table C2.1: Characteristic values for Seismic Performance Category C1						
FBS II A4			8	10	12	
Nominal embedment depth	h_{nom}	[mm]	65	85	100	
Steel failure for tension load and shear load C1						
Characteristic resistance	$N_{Rk,s,C1}$	[kN]	27,8	43,8	67,7	
	$V_{Rk,s,C1}$		18,1	29,3	36,6	
Pullout failure						
Characteristic resistance in cracked concrete	$N_{Rk,p,C1}$	[kN]	9,0	16,0	- ¹⁾	
Concrete cone failure						
Effective embedment depth	h_{ef}	[mm]	52	68	81	
Concrete cone failure	Edge distance		$C_{cr,N}$	1,5 h_{ef}		
	Spacing		$S_{cr,N}$	3 h_{ef}		
Installation safety factor	γ_{inst}	[-]	1,0			
Concrete pryout failure						
k-factor	k_8	[-]	1,0	2,0		
Concrete edge failure						
Effective length in concrete	$l_f = h_{nom}$	[mm]	65	85	100	
Nominal diameter of screw	d_{nom}		8	10	12	
¹⁾ Pullout failure not decisive.						
Table C2.2: Characteristic values for Seismic Performance Category C2						
Gap between screw shaft and fixture must be filled with mortar						
FBS II A4			8	10	12	
Nominal embedment depth	h_{nom}	[mm]	65	85	100	
Steel failure for tension load and shear load C2						
Characteristic resistance	$N_{Rk,s,C2}$	[kN]	27,8	43,8	67,7	
	$V_{Rk,s,C2}$		9,7	8,8	19,7	
Pullout failure						
Characteristic resistance in cracked concrete	$N_{Rk,p,C2}$	[kN]	2,8	5,0	7,3	
Concrete cone failure						
Effective embedment depth	h_{ef}	[mm]	52	68	81	
Concrete cone failure	Edge distance		$C_{cr,N}$	1,5 h_{ef}		
	Spacing		$S_{cr,N}$	3 h_{ef}		
Robustness safety factor	γ_{inst}	[-]	1,0			
Concrete pryout failure						
k-factor	k_8	[-]	1,0	2,0		
Concrete edge failure						
Effective length in concrete	$l_f = h_{nom}$	[mm]	65	85	100	
Nominal diameter of screw	d_{nom}		8	10	12	
fischer concrete screw ULTRACUT FBS II A4					Annex C2 of European Technical Assessment ETA-17/0740	
Characteristic values for Seismic Performance Category C1 and C2						

Table C3.1: Characteristic values for resistance to fire				8	10	12	
FBS II A4							
Nominal embedment depth	h_{nom}	[mm]		65	85	100	
Steel failure for tension load and shear load ($F_{Rk,s,fi} = N_{Rk,s,fi} = V_{Rk,s,fi}$)							
Characteristic resistance for head shape	US, US TX	$F_{Rk,s,fi}$	R30	[kN]	6,4	11,0	15,2
			R60		4,7	8,1	11,2
			R90		2,9	5,2	7,3
			R120		2,0	3,8	5,3
	SK	$F_{Rk,s,fi}$	R30		2,1	3,0	-
			R60		1,7	2,3	-
			R90		1,2	1,6	-
			R120		1,0	1,2	-
	US, US TX	$M^0_{Rk,s,fi}$	R30	[Nm]	7,2	15,4	25,3
			R60		5,2	11,4	18,7
			R90		3,3	7,3	12,1
			R120		2,3	5,3	8,8
	SK	$M^0_{Rk,s,fi}$	R30		2,4	4,2	-
			R60		1,9	3,2	-
			R90		1,4	2,2	-
			R120		1,1	1,7	-
Pullout failure							
Characteristic resistance	$N_{Rk,s,fi}$	R30	[kN]	2,4	4,3	6,3	
		R60					
		R90					
		R120					1,9
Concrete cone failure							
Characteristic resistance	$N_{Rk,s,fi}$	R30	[kN]	3,4	6,6	10,2	
		R60					
		R90					
		R120					2,7
Edge distance							
R30 to R120	$c_{cr,fi}$	[mm]	2 h_{ef}				
In case of fire attack from more than one side, the minimum edge distance shall be ≥ 300 mm							
Spacing							
R30 to R120	$s_{cr,fi}$	[mm]	2 $c_{cr,fi}$				
Concrete pryout failure							
R30 to R120	k	[-]	1,0	2,0			
The anchorage depth has to be increased for wet concrete by at least 30 mm compared to the given value							
fischer concrete screw ULTRACUT FBS II A4					Annex C3 of European Technical Assessment ETA-17/0740		
Characteristic values for resistance to fire							

Table C4.1: Displacements due to tension loads (static and quasi-static)

FBS II A4			8	10	12
Nominal embedment depth	h_{nom}	[mm]	65	85	100
Tension load in cracked concrete	N	[kN]	4,5	8,1	12,0
Displacement in cracked concrete	δ_{N0}	[mm]	0,4	0,7	1,4
	$\delta_{N\infty}$		1,1	1,8	1,9
Tension load in uncracked concrete	N	[kN]	7,1	11,9	17,1
Displacement in uncracked concrete	δ_{N0}	[mm]	0,7	0,8	1,25
	$\delta_{N\infty}$		0,7	0,8	1,25

Table C4.2: Displacements due to shear loads (static and quasi-static)

FBS II A4			8	10	12
Nominal embedment depth	h_{nom}	[mm]	65	85	100
Shear load in cracked and uncracked concrete	V	[kN]	15,9	20,9	26,2
Displacement (the gap between fastener and fixture is subtracted)	δ_{V0}	[mm]	2,7	3,5	2,9
	$\delta_{V\infty}$		4,1	5,3	4,4

Table C4.3: Displacements due to tension loads (Seismic Performance Category C2)

FBS II A4			8	10	12
Nominal embedment depth	h_{nom}		65	85	100
Displacement DLS	$\delta_{N,C2(DLS)}$	[mm]	0,9	0,9	1,1
Displacement ULS	$\delta_{N,C2(ULS)}$		2,5	2,7	3,2

Table C4.4: Displacements due to shear loads (Seismic Performance Category C2)

FBS II A4			8	10	12
Nominal embedment depth	h_{nom}		65	85	100
Displacement DLS	$\delta_{V,C2(DLS)}$	[mm]	1,6	1,7	2,6
Displacement ULS	$\delta_{V,C2(ULS)}$		5,0	3,8	6,6

fischer concrete screw ULTRACUT FBS II A4

Displacements due to tension and shear loads

Annex C4
of European
Technical Assessment
ETA-17/0740