

PRESTANDEDEKLARATION

DoP 0370

för fischer Betongskruv ULTRACUT FBS II R (Metallankare för användning i betong)

SV

1. Produkttypens unika identifikationskod: **DoP 0370**
2. Avsedd användning/avsedda användningar: **Infästning i efterhand i sprucken och osprucken betong, se bilaga, särskilt bilagor B1 - B5.**
3. Tillverkare: **fischerwerke GmbH & Co. KG, Klaus-Fischer-Str. 1, 72178 Waldachtal, Tyskland**
4. Tillverkarens representant: **-**
5. System för bedömning och fortlöpande kontroll av prestanda: **1**
6. Europeiskt bedömningsdokument: **EAD 330232-01-0601**
Europeisk teknisk bedömning: **ETA-17/0740; 2025-01-08**
Tekniskt bedömningsorgan: **DIBt- Deutsches Institut für Bautechnik**
Anmält/anmälda organ: **2873 TU Darmstadt**

7. Angiven prestanda:

Mekanisk hållfasthet och stabilitet (BWR 1)

Karakteristisk bärförmåga för spänning (för statisk och kvasi-statisk belastning) Metod A:

Stålets motståndskraft: Bilagor C1

Motstånd mot att skruven dras ut: Bilagor C1

Motstånd i betongkonen: Bilagor C1

Kraftighet: Bilagor C1

Minsta kant- och axelavstånd: Bilagor C4

Kantavstånd för att slippa sprickor under last: Bilagor C1

Karakteristisk bärförmåga för skjuvning (för statisk och kvasi-statisk belastning):

Motstånd i stålet (tvärlast): Bilagor C1

Motstånd mot fläkning: Bilagor C1

Karakteristisk motstånd för förenklad design:

Metod B: NPD

Metod C: NPD

Förskjutningar:

Förskjutningar under statisk och kvasistatisk belastning: Bilagor C4

Karakteristiskt motstånd och Förskjutningar för seismiska prestandakategorier C1 och C2:

Motstånd mot draglast, förskjutningar, kategori C1: Bilaga C2

Motstånd mot draglast, förskjutningar, kategori C2: Bilaga C2

Motstånd mot tvärlast, förskjutningar, kategori C1: Bilaga C2

Motstånd mot tvärlast, förskjutningar, kategori C2: Bilaga C2

Faktor cirkulärt hål: Bilaga C2

Säkerhet vid brand (BWR 2)

Reaktion vid brand: Klass (A1)

Motståndskraft mot eld:

Brandmotstånd i stålet (tvärlast): Bilaga C3

Brandmotstånd mot utdrag (draglast): Bilaga C3

Brandmotstånd i stålet (tvärlast): Bilaga C3

Hållbarhet:

Hållbarhet: Bilagor B1

8. Lämplig teknisk dokumentation och/eller särskild teknisk dokumentation: -

Prestandan för ovanstående produkt överensstämmer med den angivna prestandan. Denna prestandadeklaration har utfärdats i enlighet med förordning (EU) nr 305/2011 på eget ansvar av den tillverkare som anges ovan.

Undertecknad på tillverkarens vägnar av:

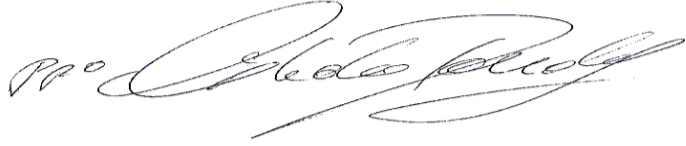

Dr. Ronald Mihala, Chef för utveckling och produktionsledning
Tumlingen, 2025-02-03



Dieter Pfaff, Chef för Internationella Produktionsfederationen och Kvalitetsledning

Denna DoP har förberetts på olika språk. I händelse av tvist om tolkningen ska den engelska versionen alltid råda.

Bilagan innehåller frivilliga och kompletterande information på engelska som överskrider (det specifika språkets) lagkrav.

Translation guidance Essential Characteristics and Performance Parameters for Annexes

Översättningsråd Grundläggande karaktäristik och prestandaparametrar för Annex

Mechanical resistance and stability (BWR 1)		
Mekanisk hållfasthet och stabilitet (BWR 1)		
Characteristic resistance under static and quasi-static loading, Method A		
Karaktäristisk bärförmåga för spänning (för statisk och kvasi-statisk belastning) Metod A:		
1	Resistance to steel failure: Stålets motståndskraft:	$N_{Rk,s}$ [kN], E_s [N/mm ²]
2	Resistance to pull-out failure: Motstånd mot att skruven dras ut:	$N_{Rk,p}$ [kN], ψ_c
3	Resistance to concrete cone failure: Motstånd i betongkonen:	$k_{cr,N}$, $k_{ucr,N}$ [-], h_{ef} , $c_{cr,N}$ [mm]
4	Robustness: Kraftighet:	γ_{inst} [-]
5	Minimum edge distance and spacing: Minsta kant- och axelavstånd:	c_{min} , s_{min} , h_{min} [mm]
6	Edge distance to prevent splitting under load: Kantavstånd för att slippa sprickor under last:	$N_{Rk,sp}^0$ [kN], $c_{cr,sp}$ [mm]
Characteristic resistance to shear load (static and quasi-static loading), Method A		
Karaktäristisk bärförmåga för skjuvning (för statisk och kvasi-statisk belastning):		
7	Resistance to steel failure under shear load: Motstånd i stålet (tvärlast):	$V_{Rk,s}^0$ [kN], $M_{Rk,s}^0$ [Nm], k_7 [-]
8	Resistance to pry-out failure: Motstånd mot fläkning:	k_8 [-]
Characteristic Resistance for simplified design		
Karaktäristisk motstånd för förenklad design:		
9	Method B: Metod B:	F_{Rk}^0 [kN], c_{cr} , s_{cr} [mm]
10	Method C: Metod C:	F_{Rk} [kN]
Displacements		
Förskjutningar:		
11	Displacements under static and quasi-static loading: Förskjutningar under statisk och kvasistatisk belastning:	δ_{N0} , $\delta_{N\infty}$, δ_{V0} , $\delta_{V\infty}$ [mm]
12	Stiffness characteristics for tension loading for non-linear spring models:	$k_{1,ucr}$, $k_{2,ucr}$, $k_{3,ucr}$, $k_{4,ucr}$, $k_{1,cr}$, $k_{2,cr}$, $k_{3,cr}$, $k_{4,cr}$ [kN/mm]
Characteristic resistance and displacements for seismic performance categories C1 and C2		
Karaktäristiskt motstånd och Förskjutningar för seismiska prestandakategorier C1 och C2:		
13	Resistance to tension load, displacements, category C1: Motstånd mot draglast, förskjutningar, kategori C1:	$N_{Rk,s,C1}$ [kN], $N_{Rk,p,C1}$ [kN]
	Resistance to tension load, displacements, category C2: Motstånd mot draglast, förskjutningar, kategori C2:	$N_{Rk,s,C2}$ [kN], $N_{Rk,p,C2}$ [kN], $\delta_{N,C2}$ [mm]
14	Resistance to shear load, displacements, category C1: Motstånd mot tvärlast, förskjutningar, kategori C1:	$V_{Rk,s,C1}$ [kN]
	Resistance to shear load, displacements, category C2: Motstånd mot tvärlast, förskjutningar, kategori C2:	$V_{Rk,s,C2}$ [kN], $\delta_{V,C2}$ [mm]
15	Factor for annular gap Faktor cirkulärt hål:	α_{gap} [-]
Safety in case of fire (BWR 2)		
Säkerhet vid brand (BWR 2)		
16	Reaction to fire: Reaktion vid brand:	Class
Resistance to fire:		
Motståndskraft mot eld:		
17	Fire resistance to steel failure (tension load): Brandmotstånd i stålet (tvärlast):	$N_{Rk,s,fi}$ [kN]
18	Fire resistance to pull-out failure (tension load): Brandmotstånd mot utdrag (draglast):	$N_{Rk,p,fi}$ [kN]
19	Fire resistance to steel failure (shear load): Brandmotstånd i stålet (tvärlast):	$V_{Rk,s,fi}$ [kN], $M_{Rk,s,fi}^0$ [Nm]
Aspects of durability		
Hållbarhet:		
20	Durability: Hållbarhet:	Class

II SPECIFIC PART OF THE EUROPEAN TECHNICAL ASSESSMENT

1 Technical description of product and intended use

Technical description of the product

fischer concrete screw UltraCut FBS II R is a concrete screw made of stainless steel. The anchor is installed in a drilled hole and anchored by mechanical interlock.

An illustration of the product is given in Annex A.

The characteristic material values, dimensions and tolerances of the anchors not indicated in Annexes shall correspond to the respective values laid down in the technical documentation of this European Technical Assessment.

The anchors are intended to be used with embedment depth given in Annex B, Table B2.1. The intended use specifications of the product are detailed in the Annex B1.

2 Specification of the intended use in accordance with the applicable European Assessment Document (hereinafter EAD)

The performances given in Section 3 are only valid if the anchor is used in compliance with the specifications and conditions given in Annex B.

The provisions made in this European Technical Assessment are based on an assumed intended working life of the anchor of 50 years.

The indications given on the working life cannot be interpreted as a guarantee given by the producer or Assessment Body, but are to be regarded only as a means for choosing the right products in relation to the expected economically reasonable working life of the works.

3 Performance of the product and references to the methods used for its assessment

3.1 Characteristics of product

Mechanical resistance and stability (BWR 1):

The essential characteristics are detailed in the Annex C1, C2 and C4.

Safety in case of fire (BWR 2):

The essential characteristics are detailed in the Annex C3.

Durability:

See annex B1.

Other Basic Requirements are not relevant.

3.2 Methods of assessment

The assessment of fitness of the anchor for the intended use in relation to the requirements for mechanical resistance and stability and safety in use in the sense of the Basic Works Requirement 1 has been made in accordance with EAD 330232-01-0601; Mechanical fasteners for use in concrete.

4 Assessment and verification of constancy of performance (hereinafter AVCP) system applied, with reference to its legal base.

4.1 AVCP system

According to the decision 1996/582/EC of the European Commission, the system(s) of assessment and verification of constancy of performance (see Annex V to Regulation (EU) No. 305/2011) is 1.

Product in the installed condition

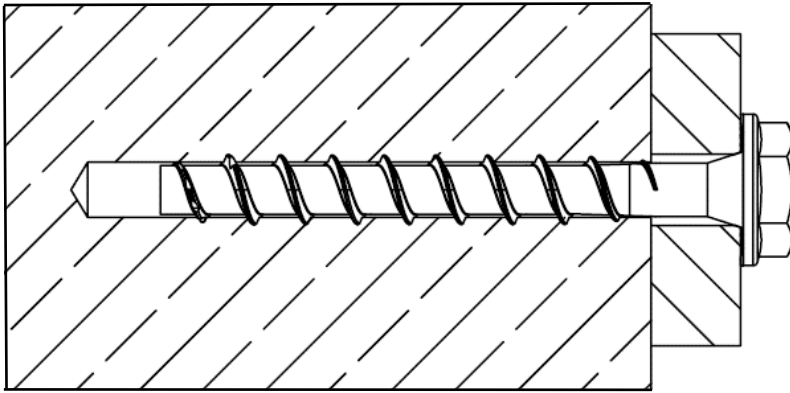

FBS II US R/
FBS II US TX R

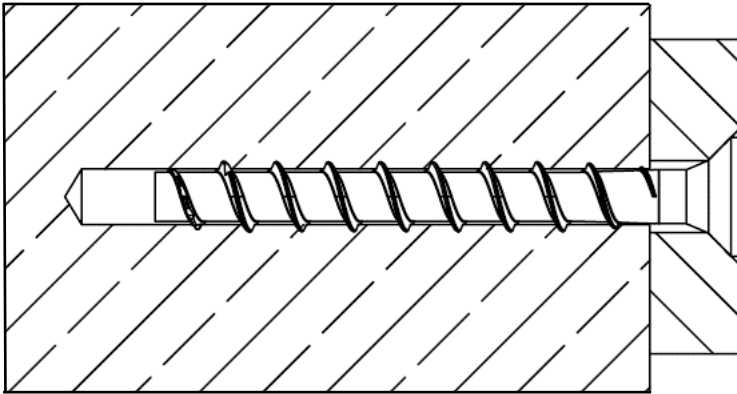

FBS II SK R

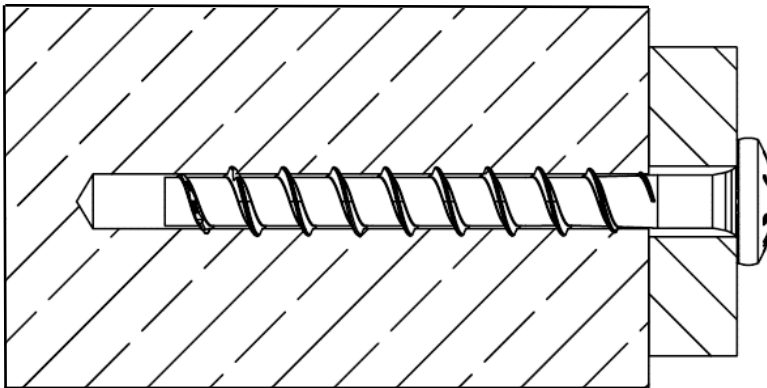

FBS II P R

(Figure not to scale)

fischer concrete screw UltraCut FBS II R

Product description
Product in the installed condition

Annex A 1

Appendix 4 / 14

Table A2.1: Geometry and material

Type of screw / size		FBS II US R / FBS II SK R / FBS II P R				
		6	8	10	12	
Thread outer diameter	d_a	[mm]	7,8	10,3	12,5	14,6
Core diameter	d_k		5,6	7,5	9,4	11,1
Shaft diameter	d_s		6,0	8,0	9,9	11,7

Material Tip: hardened steel;
Shaft and head: stainless steel EN 10088-1:2023

Coating Tip: red colour

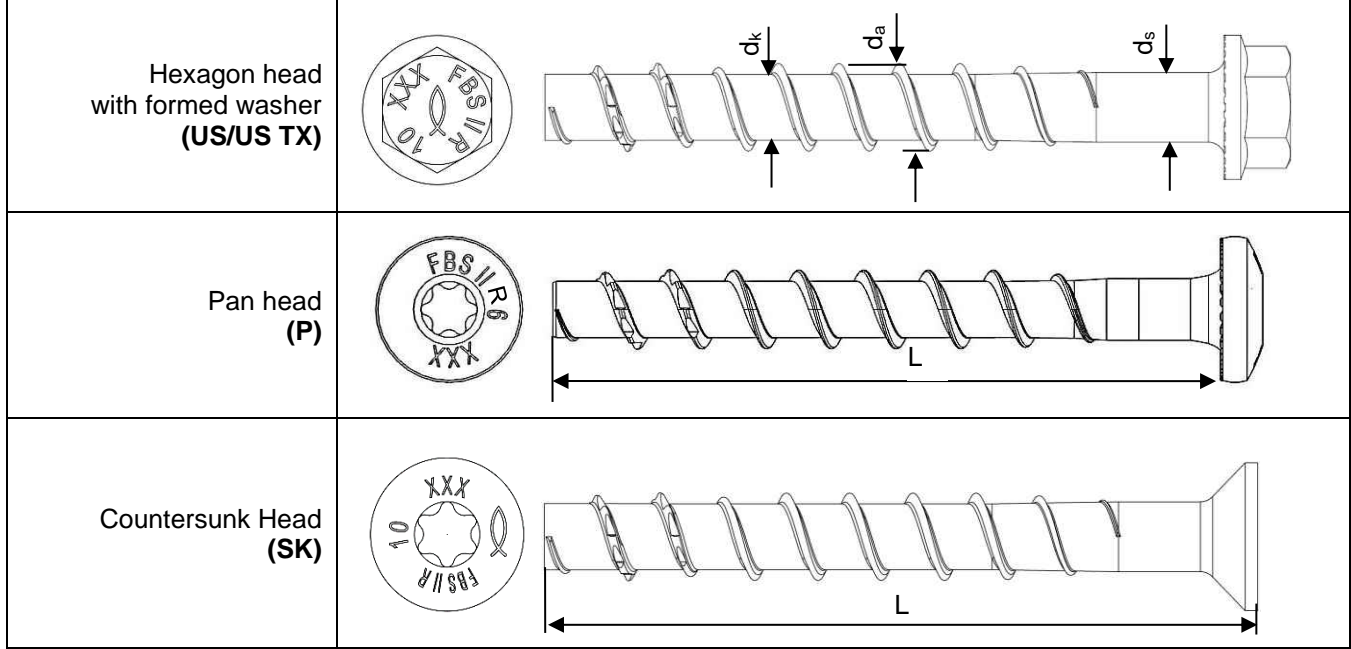

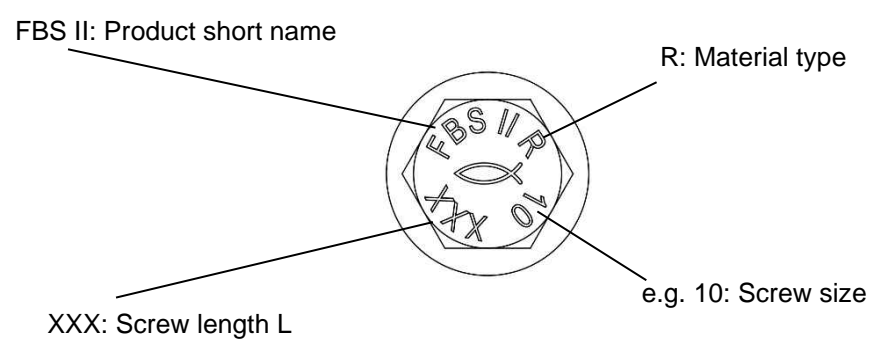

Head Marking (example)



(Figure not to scale)

fischer concrete screw UltraCut FBS II R	Annex A 2 Appendix 5 / 14
Product description Geometry and material	

Specification of intended use:

Size	FBS II R								
	6	8	10			12			
Nominal embedment depth [mm]	60	50	65	55	65	85	60	75	100
Hammer drilling 	✓								
Hollow drilling 	- 1)	✓							
Diamond drilling 									
Static and quasi-static loads	✓								
Cracked and uncracked concrete									
Fire exposure									
Seismic performance category C1	✓	- 1)	✓	- 1)	✓	- 1)	✓	- 1)	✓
Seismic performance category C2	- 1)		✓	- 1)	✓	- 1)	✓	- 1)	✓

1) No performance assessed

Base materials:

- Compacted reinforced or unreinforced normal weight concrete without fibres (cracked or uncracked) according to EN 206:2013+A2:2021
- Strength classes C20/25 to C50/60 according to EN 206:2013+A2:2021

Use conditions (Environmental conditions):

- Structures subjected to dry internal conditions (FBS II R)
- For all other conditions according to EN 1993-1-4:2006 + A1:2015, corresponding to corrosion resistance class
- CRC III: for FBS II R

Design:

- The structural design according to EN 1992-4:2018 are conducted under responsibility of a designer experienced in the field of anchorages and concrete works.
- Verifiable calculation notes and drawings are to be prepared taking account of the loads to be anchored. The position of the fastener is indicated on the design drawings (e.g. position of the screw relative to reinforcement or to supports, etc.).
- Design of fastenings according to EN 1992-4:2018 and EOTA Technical Report TR 055:2018

fischer concrete screw UltraCut FBS II R

Intended use
Specification of intended use

Annex B 1

Appendix 6 / 14

Table B2.1: Installation parameters

FBS II R		6	8		10			12		
Nominal embedment depth	h_{nom}	60	50	65	55	65	85	60	75	100
Nominal drill hole diameter	d_0	6	8		10			12		
Cutting diameter of drill bits		6,40	8,45		10,45			12,50		
Cutting diameter for diamond drillers	$d_{cut} \leq$	- 1)	8,10		10,30			12,30		
Clearance hole diameter	d_f	8,0	10,6 – 12,0		12,8 – 14,0			14,8 – 16,0		
Wrench size (US)	SW	10 / 13	13		15			17		
TX-size (SK / P / US TX))	TX	30	40		50			-		
Countersunk head diameter	d_h	13,3	18		21					
Countersunk diameter in fixture	d_c	15,2	20		23					
Drill hole depth		70	60	75	65	75	95	70	85	110
Drill hole depth (with adjustable setting)	$h_1 \geq$	- 1)	70	85	75	85	105	80	95	120
Thickness of fixture	$t_{fix} \leq$	L - h_{nom}								
Length of screw	$L_{min} =$	65	50	65	55	65	85	60	75	100
	$L_{max} =$	400	400	415	405	415	435	410	425	450
Torque impact screw driver	$T_{imp,max}$	240	450					650		
Torque impact screw driver (with adjustable setting process)	$T_{imp,max}$	- 1)	300					450		

1) No performance assessed

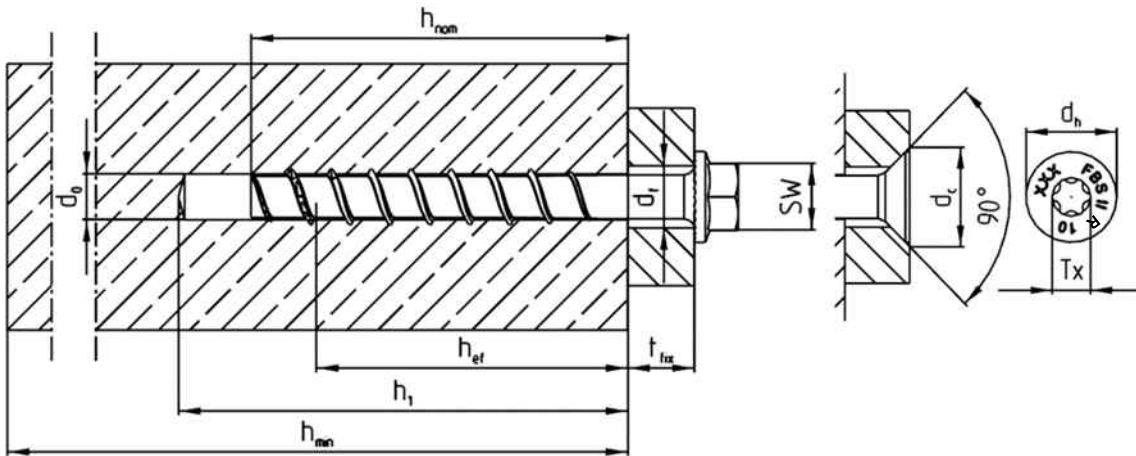

(Figure not to scale)

fischer concrete screw UltraCut FBS II R

Intended use
Installation parameters

Annex B 2

Appendix 7 / 14

Installation instruction part 1 FBS II 8/10/12 R

	<p>Step 1: Drilling of the hole:</p> <p>Drill the hole using hammer drill, hollow drill or diamond core drill</p> <p>Drill hole diameter d_0 and drill hole depth h_1 according to table B2.1</p>
	<p>Step 2: Cleaning of the drill hole - horizontal:</p> <p>Clean the drill hole. This step can be omitted in the preparation of the hole by using a hollow drill bit or diamond core drill. (recommendation: use the fischer FHD hollow drill bit)</p>
	<p>Step 2: Cleaning of the drill hole - vertical:</p> <p>Cleaning of the drill hole can be omitted, if drilling vertically upwards or if drilling vertically downwards and the hole depth has been increased. It is recommended to increase the drill hole depth by an additional $3 \times \text{drilling } \varnothing$ when drilling vertically downwards.</p>
	<p>Step 3: Installation:</p> <p>Turn in until the head is in contact with the fixture.</p> <p>Installation with any torque impact screw driver up to the maximum mentioned torque moment ($T_{\text{imp,max}}$ according to table B2.1).</p> <p>Alternatively, all other tools without an indicated torque moment are allowed (e.g. ratchet spanner). The indicated torque moments $T_{\text{imp,max}}$ for impact screw driver are not decisive for manual installation.</p>
	<p>Step 4: Checking of the correct installation:</p> <p>After installation a further turning of the screw must not be possible. The head of the screw must be in contact with the fixture and is not damaged</p>

fischer concrete screw UltraCut FBS II R

Intended use
Installation Instructions

Annex B 3

Appendix 8 / 14

Installation instruction part 2 FBS II 8/10/12 R

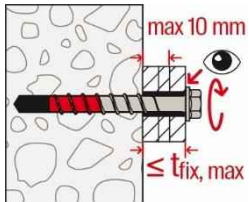
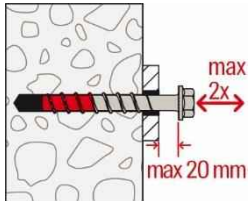
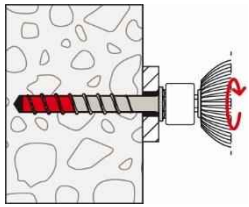

Adjustment

Optional:

It is permissible to adjust the screw twice.

Therefore, the screw may be untightened to a maximum of $L_{adj} = 20$ mm off the surface of the initial fixture. The total permissible thickness of shims added during the adjustment process

is $t_{adj} = 10$ mm.

The required nominal anchoring depth h_{nom} must be kept after the adjustment process. (see also annex B 3)

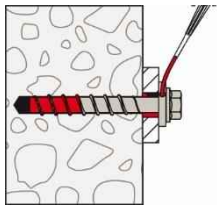

Filling of the annular gap

For seismic performance category C2 applications:

The gap between screw shaft and fixture must be filled with mortar; mortar compressive strength ≥ 50 N/mm²

(e. g. FIS V Plus, FIS HB, FIS SB or FIS EM Plus). As an aid for filling the gap, the filling disc FFD is recommended.

fischer concrete screw UltraCut FBS II R

Intended use

Installation Instructions

Annex B 4

Appendix 9 / 14

Installation instruction FBS II 6 R

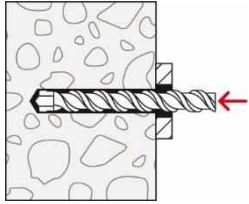

Step 1: Drilling of the hole:

Drill the hole using hammer drill

Drill hole diameter d_0 and
drill hole depth h_1 according to table B2.1

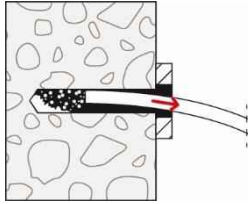

Step 2: Cleaning of the drill hole:

Clean the drill hole.

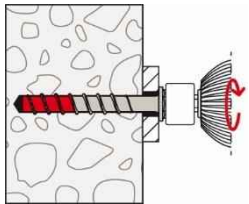

Step 3: Installation:

Turn in until the head is in contact with the fixture.

Installation with any torque impact screw driver up to the
maximum mentioned torque moment ($T_{imp,max}$ according to
table B2.1).

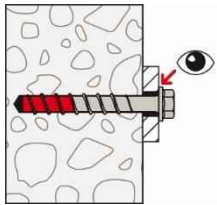

Step 4: Checking of the correct installation:

After installation a further turning of the screw must not be
possible. The head of the screw must be in contact with the
fixture and is not damaged

fischer concrete screw UltraCut FBS II R

Intended use
Installation Instructions

Annex B 5

Appendix 10 / 14

Table C1.1: Characteristic values for static and quasi-static action												
FBS II R			6		8		10			12		
Nominal embedment depth	h_{nom}	[mm]	60	50	65	55	65	85	60	75	100	
Steel failure for tension load and shear load												
Characteristic resistance	$N_{Rk,s}$	[kN]	19,3	27,8		43,8			67,7			
Partial factor	$\gamma_{Ms,N}$	-	1,5									
Characteristic resistance	$V^0_{Rk,s}$	[kN]	12,6	18,0	27,8	13,2	19,3	36,6	20,4	40,1	45,8	
Partial factor	$\gamma_{Ms,V}$	[-]	1,25									
Factor for ductility	k_7		0,75									
Characteristic bending resistance	$M^0_{Rk,s}$	[Nm]	16,1	31,3		68,5			112,8			
Pullout failure												
Characteristic resistance in concrete C20/25	uncracked	$N_{Rk,p}$	[kN]	10,0	7,0	14,0	8,5	14,0	$\geq N^0_{Rk,c^{(1)}}$	10,0	12,0	$\geq N^0_{Rk,c^{(1)}}$
	cracked	$N_{Rk,p}$	[kN]	4,0	4,0	9,0	4,5	6,0	16,0	4,5	11,0	$\geq N^0_{Rk,c^{(1)}}$
Increasing factors concrete	C25/30	ψ_c	[-]	1,07	1,12							
	C30/37			1,22								
	C35/45			1,32								
	C40/50			1,41								
	C45/55			1,50								
	C50/60			1,58								
Installation factor	γ_{inst}	[-]	1,4	1,0								
Concrete cone failure and splitting failure; concrete pryout failure												
Effective embedment depth	h_{ef}	[mm]	37	40	52	43	51	68	47	60	81	
Factor for uncracked concrete	$k_{ucr,N}$	[-]	11,0									
Factor for cracked concrete	$k_{cr,N}$		7,7									
Characteristic edge distance	$c_{cr,N}$	[mm]	$1,5 \cdot h_{ef}$									
Characteristic spacing	$s_{cr,N}$		$3 \cdot h_{ef}$									
Characteristic resistance for splitting	$N^0_{Rk,sp}$	[kN]	$\min\{N^0_{Rk,c}, N_{Rk,p}\}$	12,0	18,4	13,0	17,9	$\geq N^0_{Rk,c^{(1)}}$	15,8	22,9	$\geq N^0_{Rk,c^{(1)}}$	
Characteristic edge distance for splitting	$c_{cr,sp}$	[mm]	$1,78 \cdot h_{ef}$	$1,5 \cdot h_{ef}$								
Characteristic spacing for splitting	$s_{cr,sp}$		$3 \cdot h_{ef}$									
Factor for pryout failure	k_8	[-]	2,6	1,0			2,0	1,0	2,0			
Installation factor	γ_{inst}		1,4 ²⁾	1,0								
Concrete edge failure												
Effective length in concrete	l_f	[mm]	46	50	65	55	65	85	60	75	100	
Nominal diameter of screw	d_{nom}		6	8		10			12			
Adjustment												
Maximum thickness of shims	t_{adj}	[mm]	- ³⁾				10					
Maximum number of adjustments	n_a	[-]	- ³⁾				2					
¹⁾ $N^0_{Rk,c}$ according to EN 1992-4:2018 ²⁾ Only for concrete cone failure and splitting failure; concrete pryout failure according to EN 1992-4:2018, Table 4.1 ³⁾ No performance assessed												
fischer concrete screw UltraCut FBS II R									Annex C 1			
Performances Characteristic values for static and quasi-static action												
									Appendix 11 / 14			

Table C2.1: Characteristic values for Seismic Performance Category C1							
FBS II R			6	8	10	12	
Nominal embedment depth	h_{nom}	[mm]	60	65	85	100	
Steel failure for tension load and shear load C1							
Characteristic resistance	$N_{RK,s,C1}$	[kN]	19,3	27,8	43,8	67,7	
	$V_{RK,s,C1}$		7,5	18,1	29,3	36,6	
Without filling of the annular gap	α_{gap}	[-]	0,5				
With filling of the annular gap ¹⁾			1,0				
Pullout failure							
Characteristic resistance in cracked concrete	$N_{RK,p,C1}$	[kN]	3,5	9,0	16,0	$\geq N_{RK,c}^{0,2)}$	
Concrete cone failure							
Effective embedment depth	h_{ef}	[mm]	37	52	68	81	
Concrete cone failure	Edge distance		$c_{cr,N}$	$1,5 \cdot h_{ef}$			
	Spacing		$s_{cr,N}$	$3 \cdot h_{ef}$			
Installation factor	γ_{inst}	[-]	1,4	1,0			
Concrete pryout failure							
Factor for pryout failure	k_8	[-]	2,6	1,0	2,0		
Concrete edge failure							
Effective length in concrete	l_f	[mm]	46	65	85	100	
Nominal diameter of screw	d_{nom}		6	8	10	12	

¹⁾ Filling of the annular gap according to annex B 4

²⁾ $N_{RK,c}^0$ according to EN 1992-4:2018

Table C2.2: Characteristic values for Seismic Performance Category C2							
FBS II R			6	8	10	12	
Nominal embedment depth	h_{nom}	[mm]	- ²⁾	65	85	100	
Steel failure for tension load and shear load C2							
Characteristic resistance	$N_{RK,s,C2}$	[kN]	- ²⁾	27,8	43,8	67,7	
	$V_{RK,s,C2}$			9,7	8,8	19,7	
With filling of the annular gap ¹⁾	α_{gap}	[-]		1,0			
Pullout failure							
Characteristic resistance in cracked concrete	$N_{RK,p,C2}$	[kN]	- ²⁾	2,8	5,0	7,3	
Concrete cone failure							
Effective embedment depth	h_{ef}	[mm]	- ²⁾	52	68	81	
Concrete cone failure	Edge distance		$c_{cr,N}$	- ²⁾	$1,5 \cdot h_{ef}$		
	Spacing		$s_{cr,N}$		$3 \cdot h_{ef}$		
Installation factor	γ_{inst}	[-]	1,0				
Concrete pryout failure							
Factor for pryout failure	k_8	[-]	- ²⁾	1,0	2,0		
Concrete edge failure							
Effective length in concrete	$l_f = h_{nom}$	[mm]	- ²⁾	65	85	100	
Nominal diameter of screw	d_{nom}			8	10	12	

¹⁾ Filling of the annular gap according to annex B 4. Application without filling of the annular gap not allowed.

²⁾ No performance assessed

fischer concrete screw UltraCut FBS II R	Annex C 2 Appendix 12 / 14
Performances Characteristic values for Seismic Performance Category C1 and C2	

Table C3.1: Characteristic values for resistance to fire														
FBS II R			6	8		10			12					
Nominal embedment depth	h_{nom}	[mm]	60	50	65	55	65	85	60	75	100			
Steel failure for tension load and shear load ($F_{Rk,s,fi} = N_{Rk,s,fi} = V_{Rk,s,fi}$)														
Characteristic resistance for the head shapes	US US TX ≥SW13	$F_{Rk,s,fi}$	R30	[kN]	2,1	2,3	6,4	3,5	11,0	4,6	15,2			
			R60		1,7	1,8	4,7	2,7	8,1	3,7	11,2			
			R90		1,2	1,3	2,9	2,0	5,2	2,7	7,3			
			R120		1,0	1,0	2,0	1,6	3,8	2,2	5,3			
	SK/P ¹⁾ US SW10 ¹⁾	$F_{Rk,s,fi}$	R30	[kN]	1,8	2,1	3,0	No performance assessed						
			R60		1,4	1,7	2,3							
			R90		1,1	1,2	1,6							
			R120		0,9	1,0	1,2							
	US US TX ≥SW13	$M^0_{Rk,s,fi}$	R30	[Nm]	1,7	2,6	7,2	7,6	15,4	16,8	25,3			
			R60		1,4	2,0	5,2	6,0	11,4	13,3	18,7			
			R90		1,0	1,5	3,3	4,4	7,3	9,8	12,1			
			R120		0,8	1,2	2,3	3,6	5,3	8,0	8,8			
		SK/P ¹⁾ US SW10 ¹⁾	$M^0_{Rk,s,fi}$		R30	[Nm]	1,5	2,4	4,2	No performance assessed				
					R60		1,2	1,9	3,2					
					R90		0,9	1,4	2,2					
					R120		0,7	1,1	1,7					
Pullout failure														
Characteristic resistance	$N_{Rk,p,fi}$	R30	[kN]	1,0	1,7	2,4	2,1	3,5	4,3	2,5	3,0	6,3		
		R60												
		R90												
		R120											0,8	1,4
Concrete cone failure														
Characteristic resistance	$N_{Rk,c,fi}$	R30	[kN]	1,4	1,6	3,4	2,1	3,2	6,6	2,6	4,8	10,2		
		R60												
		R90												
		R120											1,1	1,3
Edge distance														
R30 to R120	$c_{cr,fi}$	[mm]	$2 \cdot h_{ef}$											
In case of fire attack from more than one side, the minimum edge distance shall be ≥ 300 mm														
Spacing														
R30 to R120	$s_{cr,fi}$	[mm]	$2 \cdot c_{cr,fi}$											
Concrete pryout failure														
R30 to R120	k_8	[-]	2,6	1,0		2,0	1,0	2,0						
The anchorage depth has to be increased for wet concrete by at least 30 mm compared to the given value. ¹⁾ Only FBS II 6 R														
fischer concrete screw UltraCut FBS II R									Annex C 3					
Performances Characteristic values for resistance to fire														
									Appendix 13 / 14					

Table C4.1: Displacements due to tension loads (static and quasi-static)

FBS II R			6	8			10			12		
Nominal embedment depth	h_{nom}	[mm]	60	50	65	55	65	85	60	75	100	
Tension load in uncracked concrete	N	[kN]	5,0	3,5	7,1	4,2	7,0	11,9	5,0	6,0	17,1	
Displacement in uncracked concrete	δ_{N0}	[mm]	0,1	0,5	0,7	0,4	0,6	0,8	1,0	0,9	1,25	
	$\delta_{N\infty}$		0,4	0,7	0,7	0,8	0,8	0,8	1,25	1,25	1,25	
Tension load in cracked concrete	N	[kN]	2,8	3,5	4,5	4,2	7,0	8,1	5,0	6,0	12,0	
Displacement in cracked concrete	δ_{N0}	[mm]	0,1	0,6	0,4	0,4	0,6	0,7	0,9	0,9	1,4	
	$\delta_{N\infty}$		0,5	1,5	1,1	1,0	1,8	1,8	1,4	1,7	1,9	

Table C4.2: Displacements due to shear loads (static and quasi-static)

FBS II R			6	8			10			12		
Nominal embedment depth	h_{nom}	[mm]	60	50	65	55	65	85	60	75	100	
Shear load in cracked and uncracked concrete	V	[kN]	7,8	11,0	15,9	10,4	11,9	20,9	12,7	24,9	26,2	
Displacement (the gap between fastener and fixture is subtracted)	δ_{V0}	[mm]	2,2	4,1	2,7	1,2	1,2	3,5	1,1	2,5	2,9	
	$\delta_{V\infty}$		3,4	6,2	4,1	1,8	1,8	5,3	1,7	3,8	4,4	

Table C4.3: Displacements due to tension loads (Seismic Performance Category C2)

FBS II R			6	8			10			12		
Nominal embedment depth	h_{nom}	[mm]	- ¹⁾	65			85			100		
Displacement DLS	$\delta_{N,C2}$ (DLS)			0,9			0,9			1,1		
Displacement ULS	$\delta_{N,C2}$ (ULS)			2,5			2,7			3,2		

Table C4.4: Displacements due to shear loads (Seismic Performance Category C2)

FBS II R			6	8			10			12		
Nominal embedment depth	h_{nom}	[mm]	- ¹⁾	65			85			100		
Displacement DLS	$\delta_{V,C2}$ (DLS)			1,6			1,7			2,6		
Displacement ULS	$\delta_{V,C2}$ (ULS)			5,0			3,8			6,6		

¹⁾ No performance assessed

Table C4.5: Minimum thickness of concrete members, minimum spacing and edge distance

FBS II R			6	8			10			12		
Nominal embedment depth	h_{nom}	[mm]	60	50	65	55	65	85	60	75	100	
Minimum thickness of concrete member	h_{min}		100	100	120	100	120	140	110	130	150	
Minimum spacing	s_{min}		35			40			50			
Minimum edge distance	c_{min}		35			40			50			

fischer concrete screw UltraCut FBS II R

Performances

Displacements due to tension and shear loads;
Minimum thickness of concrete members, minimum spacing and edge distance

Annex C 4

Appendix 14 / 14