

## PRESTANDEKLARATION

### DoP 0369

för fischer injektionssystem FIS V Zero (Fästdon för användning i delar av murverk)

SV

1. Produkttypens unika identifikationskod: DoP 0369
2. Avsedd användning/avsedda användningar: Efterinstallerat fäste i delar av murverk, Se bilaga, särskilt bilagor B1 - B14.
3. Tillverkare: fischerwerke GmbH & Co. KG, Otto-Hahn-Straße 15, 79211 Denzlingen, Tyskland
4. Tillverkarens representant: –
5. System för bedömning och fortlöpande kontroll av prestanda: 1
6. Europeiskt bedömningsdokument: EAD 330076-01-0604, Edition 10/2022  
Europeisk teknisk bedömning: ETA-21/0267; 2024-11-14  
Tekniskt bedömningsorgan: DIBt- Deutsches Institut für Bautechnik  
Anmält/anmälda organ: 2873 TU Darmstadt
7. Angiven prestanda:  
**Mekanisk hållfasthet och stabilitet (BWR 1)**  
Karaktäristiskt motstånd under statisk och kvasistatisk last:
  - 1 Karaktäristisk motståndskraft mot stålbrott hos ett enda ankare under dragbelastning: Se bilaga, särskilt bilagor C1, C3
  - 2 Karaktäristisk motståndskraft mot stålbrott hos ett enda ankare under skjuvbelastning med och utan nivåarm: Se bilaga, särskilt bilagor C2, C3
  - 3 Karaktäristiskt motstånd mot utdragningsbrott eller brottsbrott i tegel av ett enskilt ankare under spänningsbelastning, Reduktionsfaktor: Se bilaga, särskilt bilagor C5, C7, C10, C13, C15, C18
  - 4 Karaktäristisk motståndskraft mot lokalt tegelbrott eller tegelbrott hos ett enda ankare under skjuvbelastning: Se bilaga, särskilt bilagor C5, C7, C11, C13, C15, C19
  - 5 Karaktäristiskt motstånd mot brott mot tegelbrott hos en ankargrupp under spänningsbelastning: Se bilaga, särskilt bilagor B13, B14, C4, C6, C8, C9, C12, C14, C17
  - 6 Karaktäristisk motståndskraft mot lokalt tegelbrott eller tegelbrott hos en ankargrupp under skjuvbelastning: Se bilaga, särskilt bilagor B13, B14, C4, C5, C6, C7, C8, C9, C11, C12, C13, C14, C15, C17, C19
  - 7 Kantavstånd, avstånd, balktjocklek: Se bilaga, särskilt bilagor B13, B14, C4, C6, C8, C9, C12, C14, C16  
  - 8 Förskjutningar under drag- och skjuvbelastning: se bilaga, särskilt bilaga C21
  - 9 Maximalt installationsmoment: Se bilaga, särskilt bilagor B4-B7  
Karaktäristiskt motstånd och Förskjutningar under seismisk last:
  - 10 Motstånd mot draglast, förskjutningar: NPD
  - 11 Motstånd mot tvärlast, förskjutningar: NPD
  - 12 Faktor cirkulärt hål: NPD  
**Säkerhet vid brand (BWR 2)**
  - 13 Reaktion vid brand: Klass (A1)
  - 14 Brandmotstånd under spänning och skjuvbelastning med och utan utjämningsarm, minsta kantavstånd och mellanrum: NPD  
**Hygien, hälsa och miljö (BWR 3)**
  - 15 Innehåll, frisläppning och / eller frisläppning av farliga ämnen: NPD
8. Lämplig teknisk dokumentation och/eller särskild teknisk dokumentation: –

Prestandan för ovanstående produkt överensstämmer med den angivna prestandan. Denna prestandadeklaration har utfärdats i enlighet med förordning (EU) nr 305/2011 på eget ansvar av den tillverkare som anges ovan.

Undertecknad på tillverkarens vägnar av:

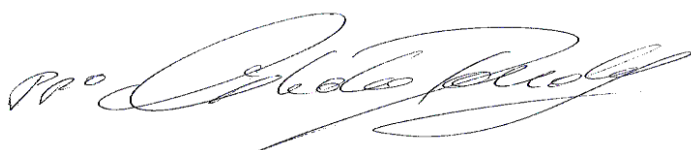

Dr. Ronald Mihala, Chef för utveckling och produktionsledning  
Tumlingen, 2024-12-12



Jürgen Grün Verkställande direktör kemi och kvalitet

Denna DoP har förberetts på olika språk. I händelse av tvist om tolkningen ska den engelska versionen alltid råda.

Bilagan innehåller frivilliga och kompletterande information på engelska som överskrider (det specifika språkets) lagkrav.

Translation guidance Essential Characteristics and Performance Parameters for Annexes

**Översättningsråd Grundläggande karaktäristik och prestandaparametrar för Annex**

Mechanical resistance and stability (BWR 1)		
Mekanisk hållfasthet och stabilitet (BWR 1)		
Characteristic resistance for static and quasi-static loading:		
<b>Karaktäristiskt motstånd under statisk och kvasistatisk last:</b>		
1	Characteristic resistance to steel failure of a single anchor under tension loading: <b>Karaktäristisk motståndskraft mot stålbrott hos ett enda ankare under dragbelastning:</b>	$N_{RK,s}$ [kN]
2	Characteristic resistance to steel failure of a single anchor under shear loading with and without level arm: <b>Karaktäristisk motståndskraft mot stålbrott hos ett enda ankare under skjuvbelastning med och utan nivåarm:</b>	$V_{RK,s}$ [kN], $M^0_{RK,s}$ [Nm]
3	Characteristic resistance to pull-out failure or brick breakout failure of a single anchor under tension loading, Reduction factor: <b>Karaktäristiskt motstånd mot utdragningsbrott eller brottsbrott i tegel av ett enskilt ankare under spänningsbelastning, Reduktionsfaktor:</b>	$N_{RK,p}$ ; $N_{RK,b}$ ; [kN] $N_{RK,p,c}$ ; $N_{RK,b,c}$ [kN], $\beta$ [-]
4	Characteristic resistance to local brick failure or brick breakout failure of a single anchor under shear loading: <b>Karaktäristisk motståndskraft mot lokalt tegelbrott eller tegelbrott hos ett enda ankare under skjuvbelastning:</b>	$V_{RK,b}$ ; $V_{RK,c,II}$ ; $V_{RK,c,I}$ [kN]
5	Characteristic resistance to brick breakout failure of an anchor group under tension loading: <b>Karaktäristiskt motstånd mot brott mot tegelbrott hos en ankargrupp under spänningsbelastning:</b>	$N^g_{RK}$ [kN], $\alpha_{g,N}$ [-]
6	Characteristic resistance to local brick failure or brick breakout failure of an anchor group under shear loading: <b>Karaktäristisk motståndskraft mot lokalt tegelbrott eller tegelbrott hos en ankargrupp under skjuvbelastning:</b>	$V^g_{RK,b}$ ; $V^g_{RK,c,II}$ ; $V^g_{RK,c,I}$ [kN]; $\alpha_{g,V,II}$ ; $\alpha_{g,V,I}$ [-]
7	Edge distances, spacing, member thickness: <b>Kantavstånd, avstånd, balktjocklek:</b>	$c_{cr}$ ; $s_{cr}$ ; $c_{min}$ ; $s_{min,II}$ ; $s_{min,I}$ ; $h_{min}$ [mm]
8	Displacements under tension and shear loading: <b>Förskjutningar under drag- och skjuvbelastning:</b>	$\delta_{N0}$ ; $\delta_{N\infty}$ ; $\delta_{V0}$ ; $\delta_{V\infty}$ [mm]
9	Maximum installation torque: <b>Maximalt installationsmoment:</b>	max. $T_{inst}$ [Nm]
Characteristic resistance and displacements for seismic loading:		
<b>Karaktäristiskt motstånd och Förskjutningar under seismisk last:</b>		
10	Resistance to tension load, displacements: <b>Motstånd mot draglast, förskjutningar:</b>	$N_{RK,s,eq}$ ; $N_{RK,eq}$ [kN], $\alpha_{N,seis}$ [-]; $\delta_{N,eq}$ [mm]
11	Resistance to shear load, displacements: <b>Motstånd mot tvärlast, förskjutningar:</b>	$V_{RK,s,eq}$ ; $V_{RK,b,eq}$ [kN], $\alpha_{V,seis}$ [-]; $\delta_{V,eq}$ [mm]
12	Factor annular gap: <b>Faktor cirkulärt håll:</b>	$\alpha_{gap}$ [-]
Safety in case of fire (BWR 2)		
Säkerhet vid brand (BWR 2)		
13	Reaction to fire: <b>Reaktion vid brand:</b>	-
14	Resistance to fire under tension and shear loading with and without level arm, minimum edge distances and spacing: <b>Brandmotstånd under spänning och skjuvbelastning med och utan utjämningsarm, minsta kantavstånd och mellanrum:</b>	$N_{RK,s,fi}$ ; $N_{RK,p,fi}$ [kN], $N_{RK,b,fi}$ ; $V_{RK,s,fi}$ [kN], $M^0_{RK,s}$ [Nm], $c_{cr,fi}$ ; $s_{cr,fi}$ [mm]
Hygiene, health and the environment (BWR 3)		
Hygien, hälsa och miljö (BWR 3)		
15	Content, emission and/or release of dangerous substances: <b>Innehåll, frisläppning och / eller frisläppning av farliga ämnen:</b>	-

## Specific Part

### 1 Technical description of the product

The fischer injection system FIS V Zero for masonry is a bonded anchor (injection type) consisting of a mortar cartridge with injection mortar fischer FIS V Zero, a perforated sleeve and an anchor rod with hexagon nut and washer or an internal threaded rod. The steel elements are made of zinc coated steel, stainless steel or high corrosion resistant steel.

The anchor rod is placed into a drilled hole filled with injection mortar and is anchored via the bond between steel element, injection mortar and masonry and mechanical interlock.

The product description is given in Annex A.

### 2 Specification of the intended use in accordance with the applicable European Assessment Document

The performances given in Section 3 are only valid if the fastener is used in compliance with the specifications and conditions given in Annex B.

The verifications and assessment methods on which this European Technical Assessment is based lead to the assumption of a working life of the fastener of at least 50 years. The indications given on the working life cannot be interpreted as a guarantee given by the producer, but are to be regarded only as a means for choosing the right products in relation to the expected economically reasonable working life of the works.

### 3 Performance of the product and references to the methods used for its assessment

#### 3.1 Mechanical resistance and stability (BWR 1)

Essential characteristic	Performance
Characteristic resistance for static and quasi-static loading	See Annexes B 4 to B 7, B 14 C 1 to C 21
Characteristic resistance and displacements for seismic loading	No performance assessed

#### 3.2 Safety in case of fire (BWR 2)

Essential characteristic	Performance
Reaction to fire	Class A1
Resistance to fire under tension and shear loading with and without lever arm. Minimum edge distances and spacing	No performance assessed

#### 3.3 Hygiene, health and the environment (BWR 3)

Essential characteristic	Performance
Content, emission and/or release of dangerous substances	No performance assessed

**4 Assessment and verification of constancy of performance (AVCP) system applied, with reference to its legal base**

In accordance with the European Assessment Document EAD 330076-01-0604 the applicable European legal act is: [97/177/EC].

The system to be applied is: 1

# Installation conditions part 1

## Anchor rods with perforated sleeve FIS H K; Installation in perforated and solid brick masonry

### Pre-positioned installation:

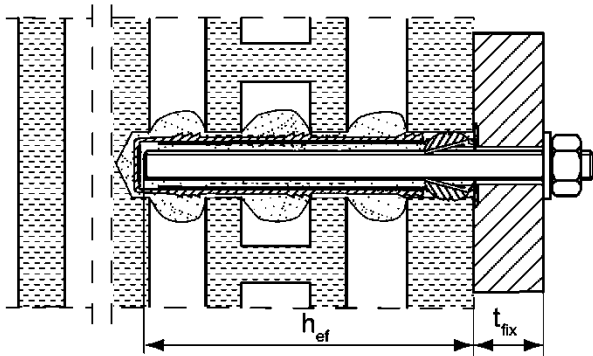

### Installation with render bridge

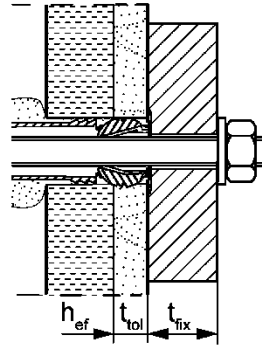

**Size of the perforated sleeve:** FIS H 12x50 K    FIS H 16x85 K    FIS H 20x85 K  
 FIS H 12x85 K    FIS H 16x130 K    FIS H 20x130 K

### Push through installation:

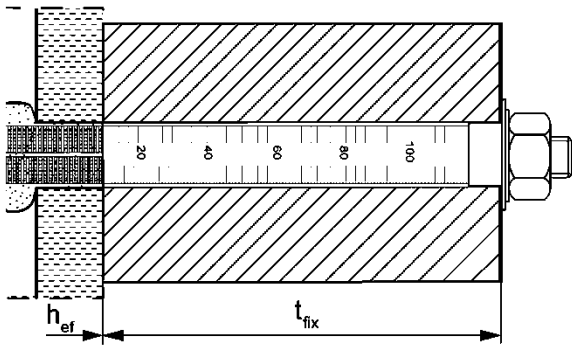

### Installation with render bridge

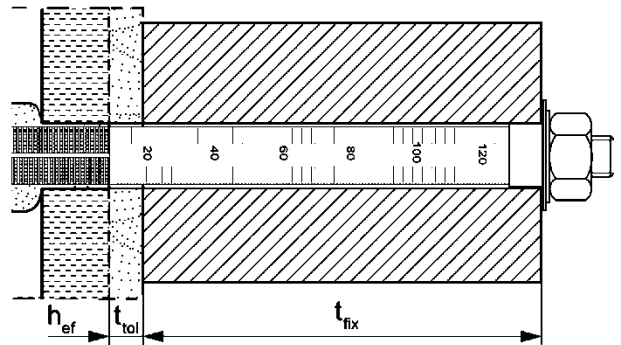

**Size of the perforated sleeve:** FIS H 18x130/200 K    FIS H 22x130/200 K

## Internal threaded anchor FIS E with perforated sleeve FIS H K; Installation in perforated and solid brick masonry

### Pre-positioned installation:

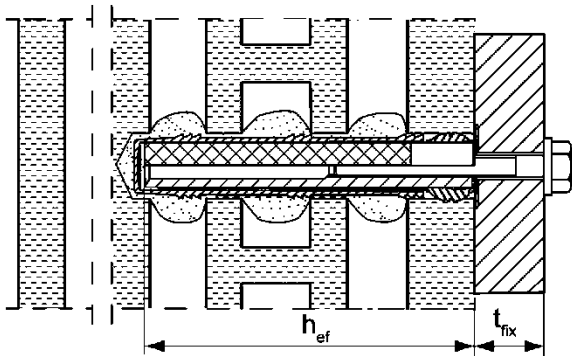

### Installation with render bridge

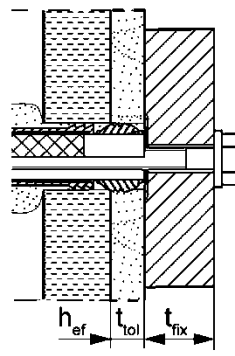

Figures not to scale

$h_{ef}$  = effective anchorage depth

$t_{fix}$  = thickness of fixture

$t_{tol}$  = thickness of unbearing layer (e.g. plaster)

fischer injection system FIS V Zero for masonry

**Product description**  
 Installation conditions part 1,  
 Anchor rods and internal threaded anchor with perforated sleeve FIS H K

**Annex A1**

Appendix 3 / 42

## Installation conditions part 2

**Anchor rods without perforated sleeve FIS H K; installation in solid brick masonry and autoclaved aerated concrete (AAC)**

**Pre-positioned installation:**

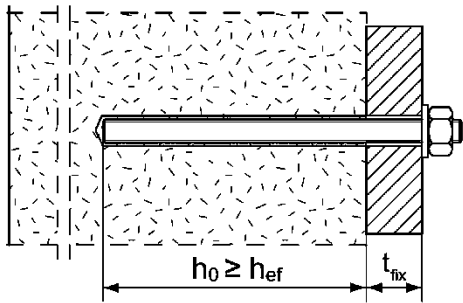

**Push through installation: Annular gap filled with mortar**

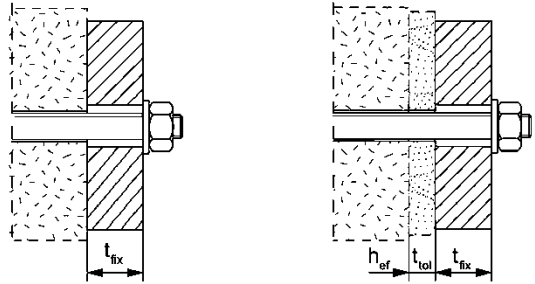

**Installation with render bridge**

**Internal threaded anchors FIS E without perforated sleeve FIS H K; installation in solid brick masonry**

**Pre-positioned installation:**

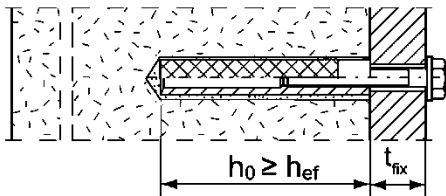

**Installation with render bridge**

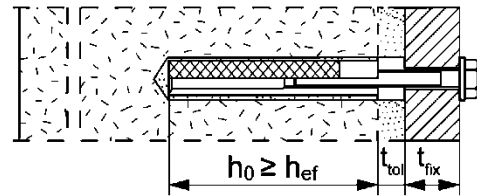

Figures not to scale

$h_0$  = depth of drill hole

$t_{tol}$  = thickness of unbearing layer (e.g. plaster)

$h_{ef}$  = effective anchorage depth

$t_{fix}$  = thickness of fixture

fischer injection system FIS V Zero for masonry

**Product description**

Installation conditions part 2,

Anchor rods and internal threaded anchor without perforated sleeve

**Annex A2**

Appendix 4 / 42

# Overview system components part 1

## Injection cartridge (shuttle cartridge) with sealing cap

Size: 360 ml, 825 ml

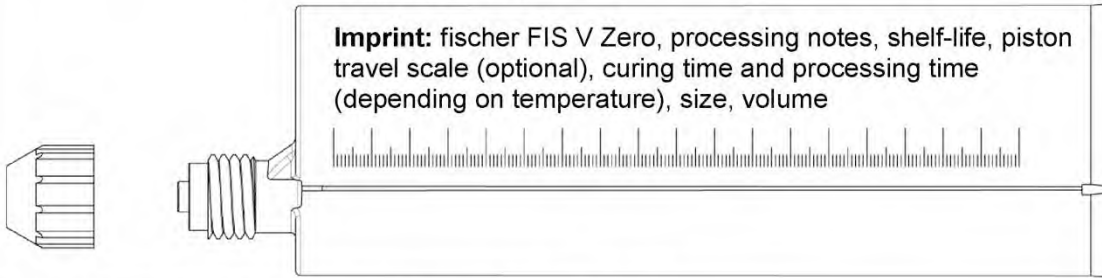

## Injection cartridge (coaxial cartridge) with sealing cap

Size: 100 ml, 150 ml, 300 ml, 380 ml, 400 ml, 410 ml

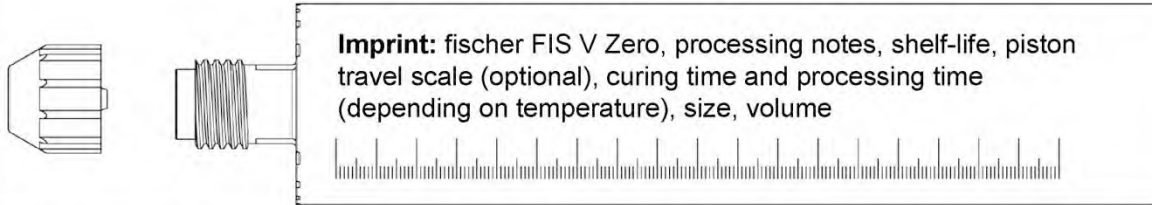

## Static mixer MR Plus or FIS JMR (only 825ml) and extension tube

Static mixer FIS MR Plus

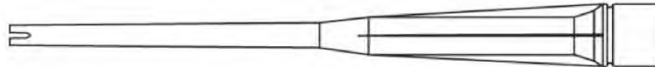

Static mixer FIS JMR

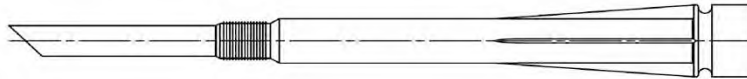

Extension tube

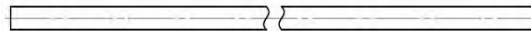

## Cleaning brush BS

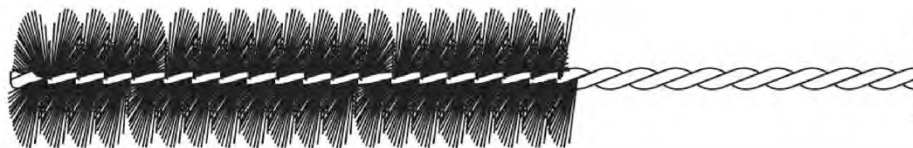

## Blow-out pump ABG or ABP

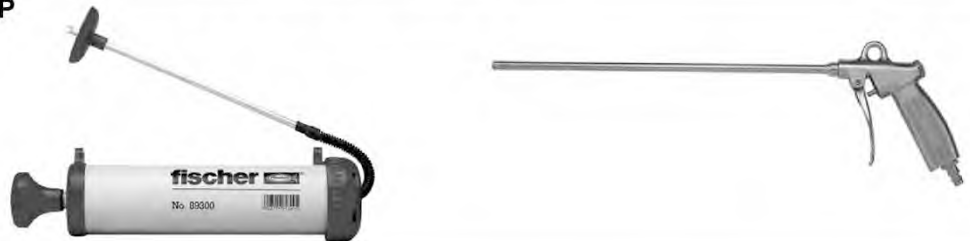

Figures not to scale

fischer injection system FIS V Zero for masonry

### Product description

Overview system components part 1: cartridge / static mixer / cleaning tools

**Annex A3**

Appendix 5 / 42

# Overview system components part 2

## fischer anchor rod



Size: M8, M10, M12, M16

## Internal threaded anchor FIS E



Size: 11x85 M8  
15x85 M10 / M12

## Perforated sleeve FIS H K



Size: FIS H 12x50 K  
FIS H 12x85 K  
FIS H 16x85 K  
FIS H 20x85 K



Size: FIS H 16x130 K  
FIS H 20x130 K

## Perforated sleeve FIS H K (push through installation)

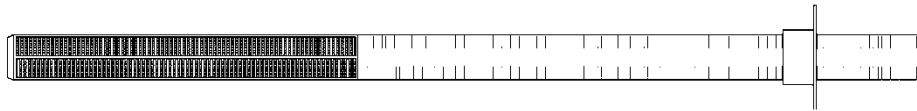

Size:  
FIS H 18x130/200 K  
FIS H 22x130/200 K

## Washer

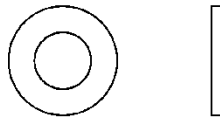

## Hexagon nut



Figures not to scale

fischer injection system FIS V Zero for masonry

### Product description

Overview system components part 2: Metal parts / perforated sleeves FIS H K

**Annex A4**



Appendix 6 / 42



<b>Table A5.1: Materials</b>				
<b>Part</b>	<b>Designation</b>	<b>Material</b>		
1	Injection cartridge	Mortar, hardener; filler		
	Steel grade	Steel	Stainless steel R	High corrosion-resistant steel HCR
		zinc plated	acc. to EN 10088-1:2023 Corrosion resistance class CRC III acc. to EN 1993-1-4:2020	acc. to EN 10088-1:2023 Corrosion resistance class CRC V acc. to EN 1993-1-4:2020
2	Anchor rod	Property class 4.6; 4.8; 5.8 or 8.8; EN ISO 898-1: 2013 zinc plated $\geq 5\mu\text{m}$ , EN ISO 4042:2022 Zn5/An(A2K) or hot-dip galvanised EN ISO 10684:2004+AC:2009 $f_{uk} \leq 1000 \text{ N/mm}^2$ $A_5 > 8\%$ fracture elongation	Property class 50, 70 or 80 EN ISO 3506-1:2020 1.4401; 1.4404; 1.4578; 1.4571; 1.4439; 1.4362; 1.4062; 1.4662; 1.4462; EN 10088-1:2023 $f_{uk} \leq 1000 \text{ N/mm}^2$ $A_5 > 8\%$ fracture elongation	Property class 50 or 80 EN ISO 3506-1:2020 or property class 70 with $f_{yk} = 560 \text{ N/mm}^2$ 1.4565; 1.4529 EN 10088-1:2023 $f_{uk} \leq 1000 \text{ N/mm}^2$ $A_5 > 8\%$ fracture elongation
3	Washer ISO 7089:2000	zinc plated $\geq 5\mu\text{m}$ , ISO 4042:2022 Zn5/An(A2K) or hot-dip galvanised EN ISO 10684:2004	1.4401; 1.4404; 1.4578; 1.4571; 1.4439; 1.4362; EN 10088-1:2023	1.4565; 1.4529 EN 10088-1:2023
4	Hexagon nut	Property class 5 or 8; EN ISO 898-2:2012 zinc plated $\geq 5\mu\text{m}$ , ISO 4042:2022 Zn5/An(A2K) or hot-dip galvanised ISO 10684:2004	Property class 50, 70 or 80 EN ISO 3506-1:2020 1.4401; 1.4404; 1.4578; 1.4571; 1.4439; 1.4362; EN 10088-1:2023	Property class 50, 70 or 80 EN ISO 3506-1:2020 1.4565; 1.4529 EN 10088-1:2023
5	Internal threaded anchor FIS E	Property class 5.8; EN 10277-1:2018 zinc plated $\geq 5\mu\text{m}$ , ISO 4042:2022 Zn5/An(A2K)	Property class 70 EN ISO 3506-1:2020 1.4401; 1.4404; 1.4578; 1.4571; 1.4439; 1.4362; EN 10088-1:2023	Property class 70 EN ISO 3506-1:2020 1.4565; 1.4529 EN 10088-1:2023
6	Commercial standard screw or threaded rod for internal threaded anchor FIS E	Property class 5.8 or 8.8; EN ISO 898-1:2013 zinc plated $\geq 5\mu\text{m}$ , ISO 4042:2022 Zn5/An(A2K)	Property class 70 EN ISO 3506-1:2020 1.4401; 1.4404; 1.4578; 1.4571; 1.4439; 1.4362; EN 10088-1:2023	Property class 70 EN ISO 3506-1:2020 1.4565; 1.4529 EN 10088-1:2023
7	Perforated sleeve FIS H K	PP / PE		
fischer injection system FIS V Zero for masonry				
<b>Product description</b> Materials				<b>Annex A5</b>  Appendix 7 / 42

# Specifications of intended use (part 1)

**Table B1.1:** Overview installation and use

		fischer injection system FIS V Zero for masonry	
Hole drilling with hammer drill mode 		all bricks	
Hole drilling with rotary drill mode 		all bricks	
Static and quasi-static load		all bricks	
Use conditions	dry masonry	all bricks	
Installation	Pre-positioned	Anchor rod or internal threaded anchor (in solid brick masonry and autoclaved aerated concrete)	Perforated sleeve with anchor rod or internal threaded anchor (in perforated and solid brick masonry)  Size: FIS H 12x50 K FIS H 12x85 K FIS H 16x85 K FIS H 16x130 K FIS H 20x85 K FIS H 20x130 K
	Push through	Anchor rod (in solid brick masonry and autoclaved aerated concrete)	Perforated sleeve with anchor rod (in perforated and solid brick masonry)  Size: FIS H 18x130/200 K FIS H 22x130/200 K
Installation and use conditions	condition d/d (dry/dry)	all bricks	
Installation temperature		$T_{i,min} = -10\text{ °C}$ to $T_{i,max} = +40\text{ °C}$	
Service temperature	Temperature range Ta	-40 °C to +40 °C	(max. short term temperature +40 °C max. long term temperature +24 °C)
	Temperature range Tb	-40 °C to +80 °C	(max. short term temperature +80 °C max. long term temperature +50 °C)
	Temperature range Tc	-40 °C to +120 °C	(max. short term temperature +120 °C; max. long term temperature +72 °C)

fischer injection system FIS V Zero for masonry		<b>Annex B1</b>  Appendix 8 / 42
Intended use Specifications (part 1)		

## Specifications of intended use (part 2)

### Anchorage subject to:

- Static and quasi-static loads

### Base materials:

- Solid brick masonry (base material group b) and AAC masonry (base material group d), acc. to Annex B 12
- Hollow brick masonry (base material group c), according to Annex B12
- Minimum thickness of masonry member is  $h_{ef}+30\text{mm}$
- Mortar strength class of the masonry M2,5 at minimum according to EN 998-2:2016
- For other bricks in solid masonry, hollow, perforated masonry or AAC masonry the characteristic resistance of the anchor may be determined by job site tests according to EOTA Technical Report TR 053:2016-04 under consideration of the  $\beta$ -factor according to Annex C20, Table C20.1

Note (only applies to solid bricks and AAC):

The characteristic resistance is also valid for larger brick sizes, higher mean compressive strength and higher mean gross dry density of the masonry unit.

### Temperature Range:

- **Ta:** from  $-40^{\circ}\text{C}$  to  $+40^{\circ}\text{C}$  (max. short term temperature  $+40^{\circ}\text{C}$  and max. long term temperature  $+24^{\circ}\text{C}$ )
- **Tb:** from  $-40^{\circ}\text{C}$  to  $+80^{\circ}\text{C}$  (max. short term temperature  $+80^{\circ}\text{C}$  and max. long term temperature  $+50^{\circ}\text{C}$ )
- **Tc:** from  $-40^{\circ}\text{C}$  to  $+120^{\circ}\text{C}$  (max. short term temperature  $+120^{\circ}\text{C}$  and max. long term temperature  $+72^{\circ}\text{C}$ )

### Use conditions (Environmental conditions):

- Structures subject to dry internal conditions (zinc plated steel, stainless steel or high corrosion resistant steel)
- For all other conditions according to EN 1993-1-4:2006+A2:2020 corresponding to corrosion resistance classes to Annex A5, Table A5.1.

fischer injection system FIS V Zero for masonry

**Intended use**  
Specifications (part 2)

**Annex B2**

Appendix 9 / 42

## Specifications of intended use (part 2 continued)

### Design:

- The anchorages have to be designed in accordance with EOTA Technical Report TR 054:2022-07, Design method A under the responsibility of an experienced in anchorages and masonry work.

Applies to all bricks, if no other values are specified:

$$N_{Rk} = N_{Rk,b} = N_{Rk,p} = N_{Rk,b,c} = N_{Rk,p,c}$$

$$V_{Rk} = V_{Rk,b} = V_{Rk,c,II} = V_{Rk,c,I}$$

For the Calculation of pulling out a brick under tension load  $N_{Rk,pb}$  or

pushing out a brick under shear load  $V_{Rk,pb}$  see EOTA Technical Report TR 054:2022-07.

$N_{Rk,s}$ ,  $V_{Rk,s}$  and  $M^0_{Rk,s}$  see annex C1-C3

Factors for job site tests see Annex C20 and displacements see Annex C21

- Verifiable calculation notes and drawings have to be prepared taking account the relevant masonry in the region of the anchorage, the loads to be transmitted and their transmission to the supports of the structure. The position of the anchor is indicated on the design drawings.

### Installation:

- Condition d/d: Installation and use in structures subject to dry, internal conditions
- Hole drilling see Annex B1.1
- In case of aborted hole: The hole shall be filled with mortar
- Bridging of unbearing layer (e.g. plaster) at perforated brick masonry see Annex B6, Table B6.1
- Anchor installation carried out by appropriately qualified personnel and under the supervision of the person responsible for technical matters of the site
- Fastening screws or anchor rods (including nut and washer) must comply with the appropriate material and property class of the fischer internal threaded anchor FIS E.
- Minimum curing time see Annex B8, Table B8.2
- Commercial standard threaded rods, washers and hexagon nuts may also be used if the following requirements are fulfilled:

Material dimensions and mechanical properties of the metal parts according to the specifications are given in Annex A5, Table 5.1

Conformation of material and mechanical properties of the metal parts by inspection certificate 3.1 according to EN 10204:2004, the documents shall be stored

Marking of the anchor rod with the effective anchorage depth. This may be done by the manufacturer of the rod or by a person on job site

fischer injection system FIS V Zero for masonry

**Intended use**  
Specifications (part 2 continued)

**Annex B3**

Appendix 10 / 42

**Table B4.1:** Installation parameters for anchor rods in solid bricks and AAC without perforated sleeves FIS H K

Anchor rod	Thread	M8	M10	M12	M16
Nominal drill hole diameter	$d_0$ [mm]	10	12	14	18
Effective anchorage depth $h_{ef}^{1)}$ in solid brick (cycl. drill hole)	$h_{0,min}=h_{ef,min}$ [mm]	100			
Effective anchorage depth $h_{ef}^{1)}$ in solid brick (depth of drill hole $h_0 = h_{ef}$ )	$h_{ef,min}$ [mm] $h_{ef,max}$ [mm]	50 h-30, $\leq 200$			
Diameter of clearance hole in the fixture	pre-positioned installation $d_f \leq$ [mm]	9	12	14	18
	push through installation $d_f \leq$ [mm]	11	14	16	20
Diameter of cleaning brush	$d_b \geq$ [mm]	see Table B8.1			
Maximum installation torque	$\max T_{inst}$ [Nm]	see parameters of brick Annex C			

<sup>1)</sup>  $h_{ef,min} \leq h_{ef} \leq h_{ef,max}$  is possible.

**fischer anchor rods M8, M10, M12, M16**

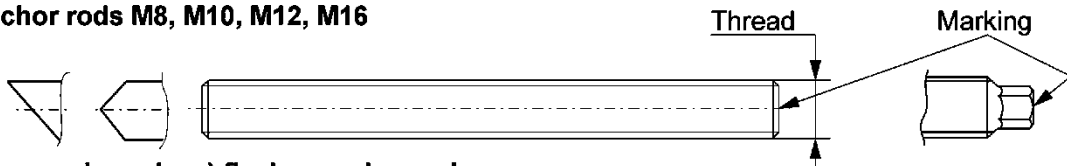

**Marking (on random place) fischer anchor rod:**

Steel zinc plated PC <sup>1)</sup> 8.8	• or +	Steel hot-dip galvanised PC <sup>1)</sup> 8.8	•
High corrosion resistant steel HCR PC <sup>1)</sup> 50	•	High corrosion resistant steel HCR PC <sup>1)</sup> 70	-
High corrosion resistant steel HCR PC <sup>1)</sup> 80	(	Stainless steel R property class 50	~
Stainless steel R property class 80	*		

Alternatively: Colour coding according to DIN 976-1: 2016;  
property class 4.6 marking according to EN ISO 898-1:2013

<sup>1)</sup> PC = property class

**Installation conditions:**

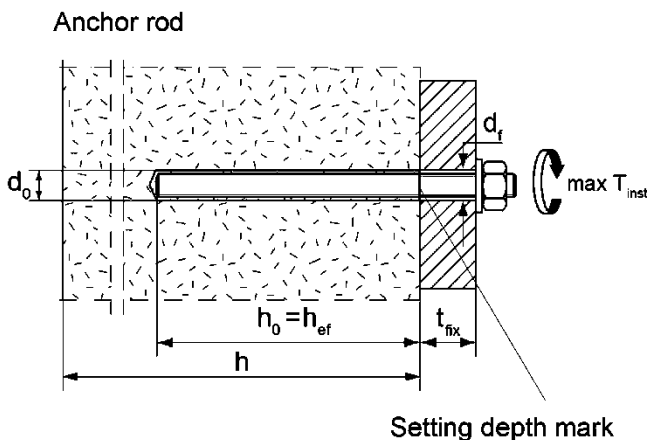

Figures not to scale

fischer injection system FIS V Zero for masonry

**Intended use**  
Installation parameters for anchor rods without perforated sleeve

**Annex B4**

Appendix 11 / 42

**Table B5.1:** Installation parameters for internal threaded anchors FIS E in solid bricks without perforated sleeves

Internal threaded anchor FIS E		11x85 M8	15x85 M10	15x85 M12
Diameter of anchor	$d_H$ [mm]	11	15	
Nominal drill hole diameter	$d_0$ [mm]	14	18	
Length of anchor	$L_H$ [mm]	85		
Effective anchorage depth	$h_0 = h_{ef}$ [mm]	85		
Diameter of cleaning brush	$d_b \geq$ [mm]	see Table B8.1		
Maximum installation torque	$\max T_{inst}$ [Nm]	see parameters of brick Annex C4-C16		
Diameter of clearance hole in the fixture	$d_f$ [mm]	9	12	14
Screw-in depth	$l_{E,min}$ [mm]	8	10	12
	$l_{E,max}$ [mm]	60		

**fischer Internal threaded anchor FIS E**

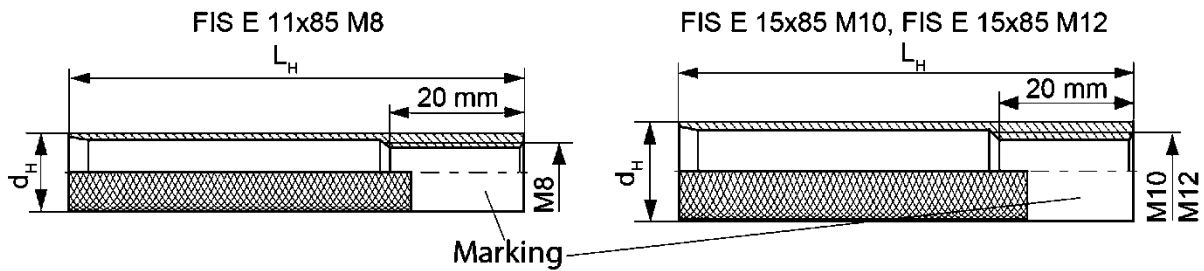

**Marking:**

Size, e.g. **M8**, Stainless steel: R, e.g. **M8 R**, High corrosion-resistant steel: HCR, e.g. **M8 HCR**

**Installation conditions:**

Internal threaded anchor

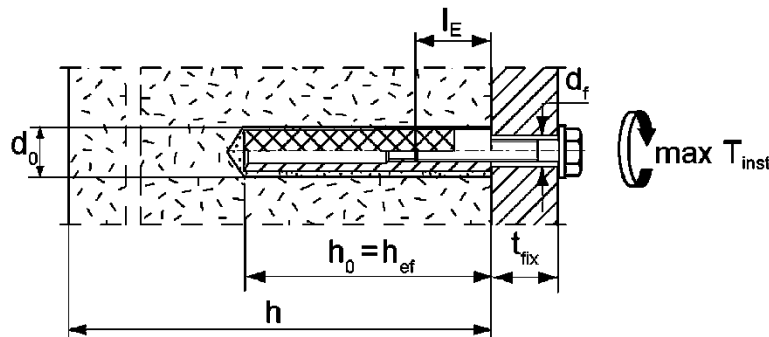

Figures not to scale

fischer injection system FIS V Zero for masonry

**Intended use**  
Installation parameters for internal threaded rods FIS E without perforated sleeve

**Annex B5**

Appendix 12 / 42

**Table B6.1: Installation parameters for anchor rods and internal threaded anchors FIS E with perforated sleeves FIS H K (pre-positioned installation)**

perforated sleeve FIS H K		12x50	12x85 <sup>2)</sup>	16x85	16x130 <sup>2)</sup>	20x85	20x130 <sup>2)</sup>
Nominal drill hole diameter $d_0 = D_{\text{sleeve, nom}}$	$d_0$ [mm]	12		16		20	
Depth of drill hole	$h_0$ [mm]	55	90	90	135	90	135
Effective anchorage depth	$h_{\text{ef, min}}$ [mm]	50	65	85	110	85	110
	$h_{\text{ef, max}}$ [mm]	50	85	85	130	85	130
Size of threaded rod	[-]	M8		M8 and M10		M12 and M16	
Size of internal threaded anchor FIS E		-	-	11x85	-	15x85	-
Diameter of cleaning brush <sup>1)</sup>	$d_b \geq$ [mm]	see Table B8.1					
Maximum installation torque	$\max T_{\text{inst}}$ [Nm]	see parameters of brick Annex C					

<sup>1)</sup> Only for solid areas in hollow bricks and solid bricks.

<sup>2)</sup> Bridging of unbearing layer (e.g. plaster) is possible. When reducing the effective anchorage depth  $h_{\text{ef, min}}$ , the values of the next shorter perforated sleeve of the same diameter must be used. The smaller value of characteristic resistance must be taken.

**Perforated sleeve**

FIS H 12x50 K; FIS H 12x85 K; FIS H 16x85 K; FIS H 16x130 K;  
FIS H 20x85 K; FIS H 20x130 K

**Marking:**

Size  $D_{\text{sleeve, nom}} \times L_{\text{sleeve}}$   
(e.g.: 16x85)

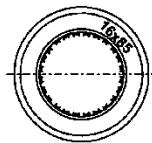

$D_{\text{sleeve, nom}}$

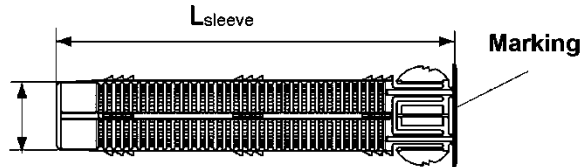

**fischer Internal threaded anchor FIS E**

FIS E 11x85 M8

FIS E 15x85 M10, FIS E 15x85 M12

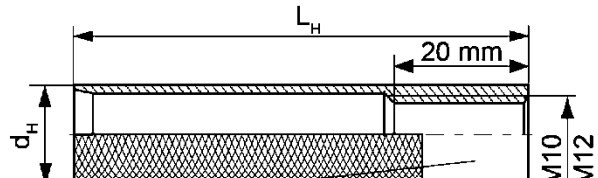
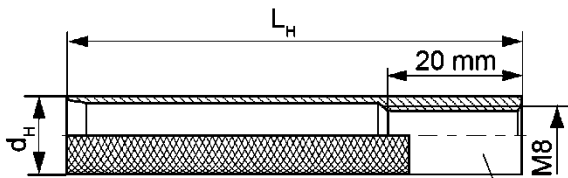

Marking

**Installation conditions:**

Anchor rod with perforated sleeve

Internal threaded anchor with perforated sleeve

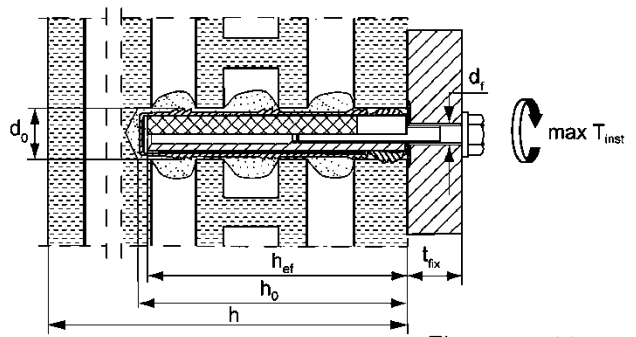
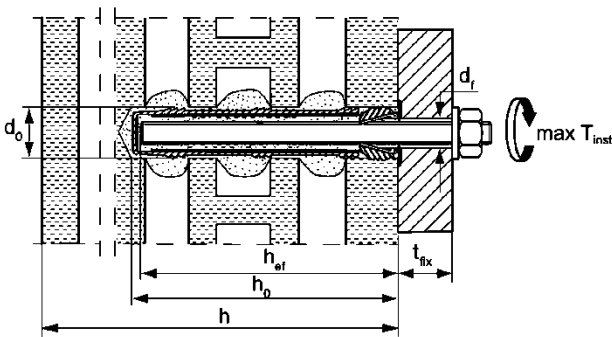

Figures not to scale

fischer injection system FIS V Zero for masonry

**Intended use**

Installation parameters for anchor rods and internal threaded anchors FIS E with perforated sleeve FIS H K (pre-positioned installation)

**Annex B6**

Appendix 13 / 42

**Table B7.1: Installation parameters for anchor rods with perforated push through sleeves (push through installation)**

Perforated sleeve FIS H K		18x130/200		22x130/200	
Nominal sleeve diameter	$D_{\text{sleeve,nom}}$ [mm]	16		20	
Nominal drill hole diameter	$d_0$ [mm]	18		22	
Depth of drill hole	$h_0$ [mm]	135			
Effective anchorage depth	$h_{\text{ef}}$ [mm]	$\geq 130$			
Diameter of cleaning brush <sup>1)</sup>	$d_b \geq$ [mm]	see Table B8.1			
Size of threaded rod	[-]	M10	M12	M16	
Maximum installation torque	$\max T_{\text{inst}}$ [Nm]	see parameters of brick Annex C			
Thickness of fixture	$t_{\text{fix,max}}$ [mm]	200			

<sup>1)</sup> Only for solid areas in hollow bricks and solid bricks.

**Perforated push through sleeve**

FIS H 18x130/200 K; FIS H 22x130/200 K

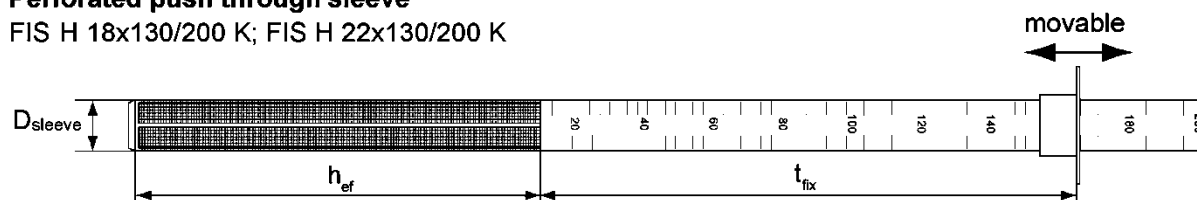

**Installation conditions:**

Anchor rod with perforated sleeve

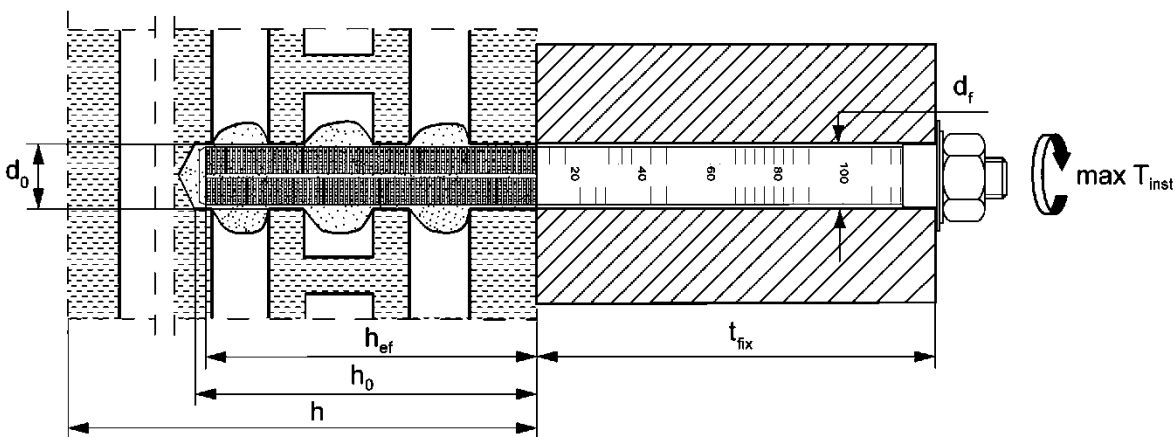

Figures not to scale

fischer injection system FIS V Zero for masonry

**Intended use**

Installation parameters for anchor rods with perforated push through sleeves (push through installation)

**Annex B7**

Appendix 14 / 42



**Table B8.1: Parameters of the cleaning brush BS (steel brush with steel bristles)**

The size of the cleaning brush refers to the drill hole diameter

Nominal drill hole diameter	$d_0$ [mm]	10	12	14	16	18	20	22
Steel brush diameter	$d_b$ [mm]	11	14	16	20	20	25	25



Only for solid areas in hollow bricks or solid bricks and autoclaved aerated concrete

**Table B8.2: Maximum processing times and minimum curing times**  
(During the curing time of the mortar the temperature of the anchoring base may not fall below the listed minimum temperature)

Temperature at anchoring base [°C]	Maximum processing time $t_{work}$	Minimum curing time $t_{cure}$
	FIS V Zero	FIS V Zero
-10 to -5 <sup>1)</sup>	6 h	72 h
> -5 to 0 <sup>1)</sup>	2 h	24 h
> 0 to 5 <sup>1)</sup>	45 min	12 h
> 5 to 10	20 min	6 h
> 10 to 15	8 min	3 h
> 15 to 20	5 min	2 h
> 20 to 25	3 min	1 h
> 25 to 30	2 min	45 min
> 30 to 40	1 min	30 min

<sup>1)</sup> Minimum cartridge temperature +5°C

Figures not to scale





fischer injection system FIS V Zero for masonry

**Intended use**Parameters of the cleaning brush (steel brush)  
Processing time and curing time**Annex B8**

Appendix 15 / 42

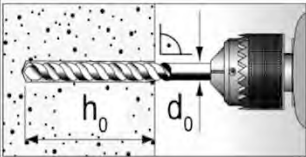
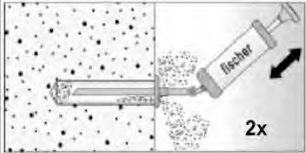
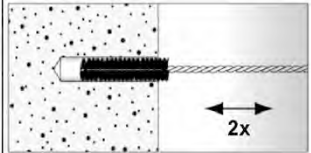
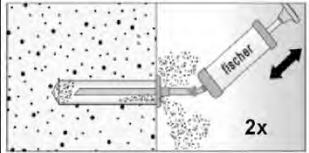
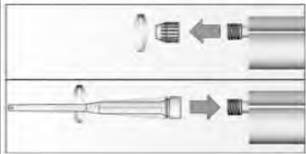
# Installation instruction part 1

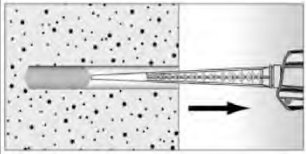
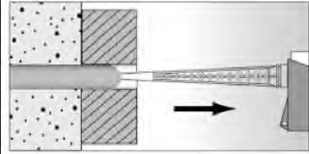
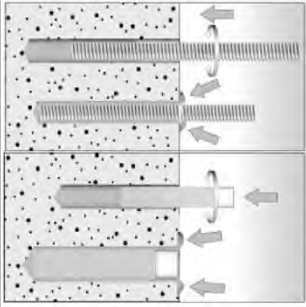
## Installation in solid brick and autoclaved aerated concrete without perforated sleeve

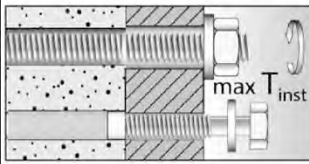
1		<p>Drill the hole (drilling method see Annex C of the respective brick) depth of drill hole <math>h_0</math> and nominal drill hole diameter <math>d_0</math> see <b>Table B4.1; B5.1</b></p>		
2				<p>Blow out the drill hole twice. Brush twice and blow out twice again.</p>
3		<p>Remove the sealing cap. Screw on the static mixer. (the spiral in the static mixer must be clearly visible)</p>		
4		<p>Place the cartridge into a suitable dispenser</p>		<p>Extrude approximately 10 cm of material out until the resin is evenly grey in colour. Do not use mortar that is not uniformly grey.</p>
5		<p>Fill approximetly 2/3 of the drill hole with mortar beginning from the bottom of the hole.<sup>1)</sup> Avoid bubbles.</p>		<p>For push through installation fill the annular gap with mortar.</p>
6		<p>Only use clean and oil-free metal parts. Mark the setting depth. Insert the anchor rod or internal threaded anchor FIS E by hand.</p> <p>Recommendation: Rotation back and forth of the anchor rod or internal threaded anchor FIS E makes pushing easy.</p> <p>When reaching the setting depth mark, excess mortar must emerge from the mouth of the drill hole.</p>		
7		<p>Do not touch. Minimum curing time see <b>Table B8.2</b></p>		<p>Mounting the fixture. max <math>T_{inst}</math> see parameter of brick.</p>

<sup>1)</sup> Exact volume of mortar see manufacturer's specifications

fischer injection system FIS V Zero for masonry

### Intended use

Installation instruction part 1





Installation in solid brick without perforated sleeve

**Annex B9**

Appendix 16 / 42

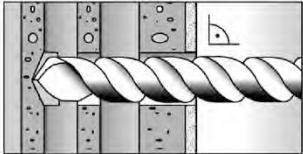
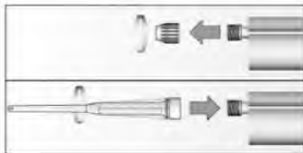
## Installation instruction part 2

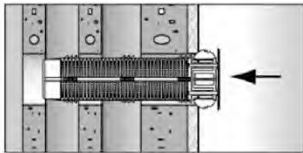
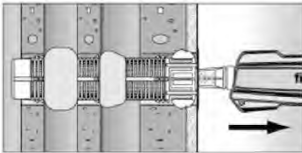
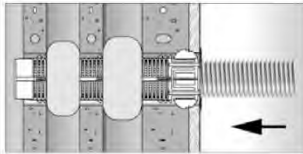
### Installation in perforated or solid brick with perforated sleeve (pre-positioned installation)

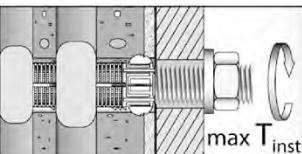
1		<p>Drill the hole (drilling method see Annex C of the respective brick). depth of drill hole <math>h_0</math> and nominal drill hole diameter <math>d_0</math> see <b>Table B6.1</b></p>	<p>When install perforated sleeves in solid bricks or solid areas of hollow bricks, also clean the hole by blowing out and brushing.</p>
2		<p>Remove the sealing cap. Screw on the static mixer. (the spiral in the static mixer must be clearly visible)</p>	
3		<p>Place the cartridge into a suitable dispenser.</p>	 <p>Extrude approximately 10 cm of material out until the resin is evenly grey in colour. Do not use mortar that is not uniformly grey.</p>
4		<p>Insert the perforated sleeve flush with the surface of the masonry or plaster.</p>	 <p>Fill the perforated sleeve completely with mortar beginning from the bottom of the hole. <sup>1)</sup></p>
5		<p>Only use clean and oil-free metal parts. Mark the setting depth. Insert the anchor rod or the internal threaded anchor FIS E by hand.</p> <p>Recommendation: Rotation back and forth of the anchor rod or internal threaded anchor FIS E makes pushing easy until reaching the setting depth mark (anchor rod) or flush with the surface (internal threaded anchor).</p>	
6		<p>Do not touch. Minimum curing time see <b>Table B8.2</b></p>	 <p>Mounting the fixture. max <math>T_{inst}</math> see parameter of brick.</p>

<sup>1)</sup> Exact volume of mortar see manufacturer's specification.

fischer injection system FIS V Zero for masonry

#### Intended use

Installation instruction part 2

Installation in perforated or solid brick with perforated sleeve (pre-positioned installation)

**Annex B10**

Appendix 17 / 42

### Installation instruction part 3

#### Installation in perforated or solid brick with perforated sleeve (push through installation)

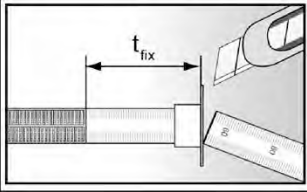
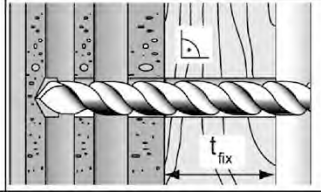
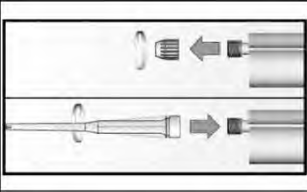
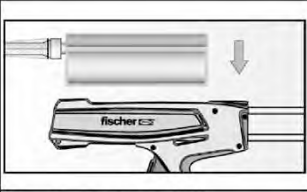
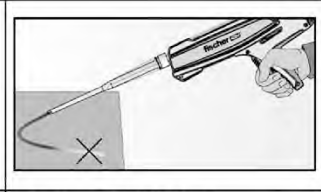
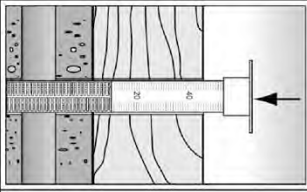
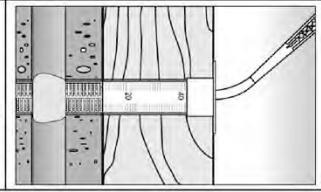
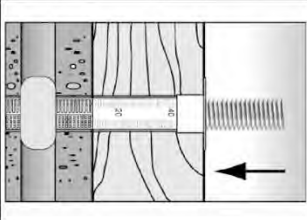
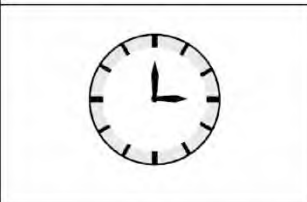
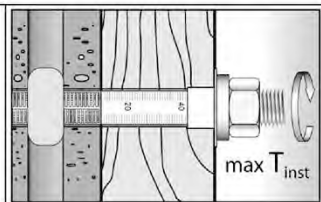
1		<p>Push the movable stop up to the correct thickness of fixture and cut the overlap.</p>		<p>Drill the hole through the fixture. Depth of drill hole (<math>h_0 + t_{fix}</math>) and nominal drill hole diameter <math>d_0</math> see <b>Table B7.1</b></p>
2		<p>Remove the sealing cap. Screw on the static mixer. (the spiral in the static mixer must be clearly visible)</p>		
3		<p>Place the cartridge into a suitable dispenser.</p>		<p>Extrude approximately 10 cm of material out until the resin is evenly grey in colour. Do not use mortar that is not uniformly grey.</p>
4		<p>Insert the perforated sleeve flush with the surface of the fixture into the drill hole.</p>		<p>Fill the sleeve with mortar beginning from the bottom of the hole. <sup>1)</sup> For deep drill holes use an extension tube.</p>
5		<p>Only use clean and oil-free metal parts. Mark the setting depth. Insert the anchor rod by hand.</p> <p>Recommendation: Rotation back and forth of the anchor rod makes pushing easy until reaching the setting depth mark (anchor rod).</p>		
6		<p>Do not touch. Minimum curing time see <b>Table B8.2</b></p>		<p>Mounting the fixture. max <math>T_{inst}</math> see parameter of brick.</p>

<sup>1)</sup> Exact volume of mortar see manufacturer's specification.

fischer injection system FIS V Zero for masonry

#### Intended use

Installation instruction part 3

Installation in perforated or solid brick with perforated sleeve (push through installation)

**Annex B11**

Appendix 18 / 42

**Table B12.1:** Overview of assessed bricks

Kind of masonry	Brick format [mm]	Mean compressive strength [N/mm <sup>2</sup> ]	Main country of origin	Mean gross dry density $\rho$ [kg/dm <sup>3</sup> ]	Annex
<b>Solid brick Mz</b>					
Solid brick Mz	≥ 230x108x55	36 - 48	Denmark	≥2,0	C4/C5
<b>Solid calcium silicate (sand - lime) brick KS / perforated calcium silicate (sand - lime) brick KSL</b>					
Solid calcium silicate brick KS	NF ≥240x115x71	8- 20	Germany	≥2,0	C6/C7
Perforated calcium silicate brick KSL	3DF 240x175x113	8 - 16	Germany	≥1,6	C8 – C11
<b>Vertical perforated brick HLz</b>					
Vertical perforated brick HLz	230x108x55	6 - 16	Denmark	≥1,6	C12/C13
<b>Lightweight aggregate concrete hollow block Hbl</b>					
Lightweight aggregate concrete hollow block Hbl	500x200x200	2 - 4	France	≥1,0	C14/C15
<b>Autoclaved aerated concrete</b>					
AAC	PP2 / AAC PP4 / AAC PP6 / AAC	-	Germany	≥0,35 ≥0,5 ≥0,65	C16-C19

**Table B12.2:** Overview dimensions of perforated and hollow bricks

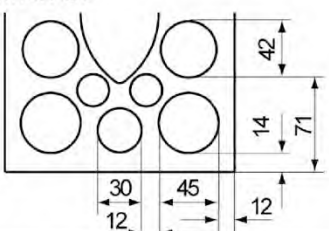
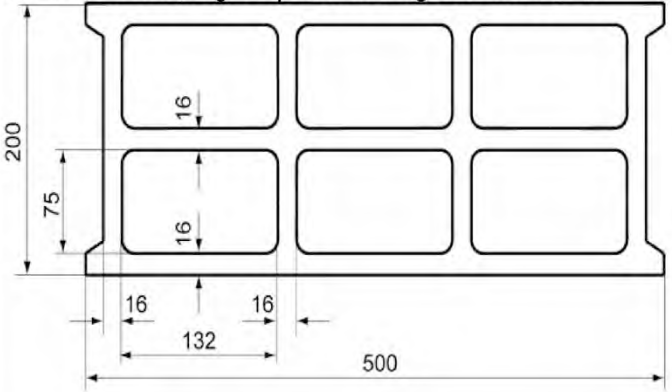
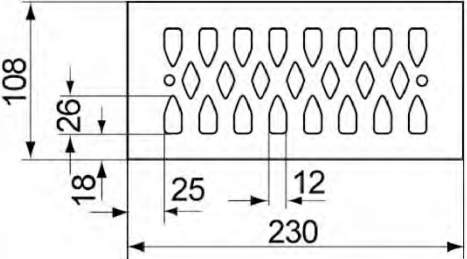
<p>Perforated calcium silicate (sand-lime) brick KSL, 3DF, EN 771-2:2011+A1:2015;; e.g. KS Wending according to Annex C8</p> 	<p>Lightweight aggregate concrete hollow block Hbl, EN 771-3: 2011+A1:2015; e.g. Sepa according to Annex C 14</p> 
<p>Vertical perforated brick HLz, EN 771-1: 2011+A1:2015; e.g. Wienerberger according to Annex C 12</p> 	<p>Measures in [mm]</p>

Figures not to scale

fischer injection system FIS V Zero for masonry	<p><b>Annex B12</b></p> <p>Appendix 19 / 42</p>
<p><b>Intended use</b>                      Overview of assessed bricks                      Overview dimensions of perforated and hollow bricks</p>	

# Spacing and edge distance

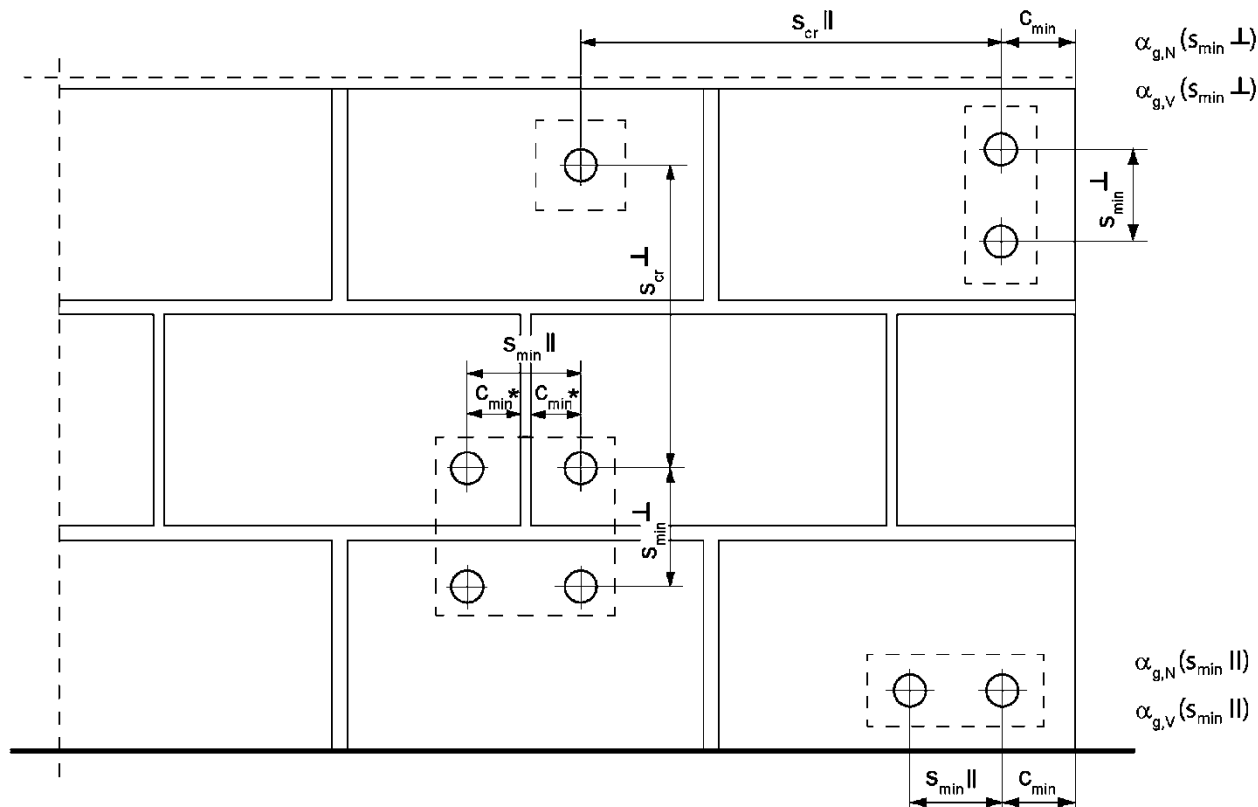

\* Only, if vertical joints are not completely filled with mortar

- $s_{min II}$  = Minimum spacing parallel to horizontal joint
- $s_{min \perp}$  = Minimum spacing perpendicular to horizontal joint
- $s_{cr II}$  = Characteristic spacing parallel to horizontal joint
- $s_{cr \perp}$  = Characteristic spacing perpendicular to horizontal joint
- $C_{cr} = C_{min}$  = Edge distance
- $\alpha_{g,N}(s_{min II})$  = Group factor for tension load, anchor group parallel to horizontal joint
- $\alpha_{g,V}(s_{min II})$  = Group factor for shear load, anchor group parallel to horizontal joint
- $\alpha_{g,N}(s_{min \perp})$  = Group factor for tension load, anchor group vertical to horizontal joint
- $\alpha_{g,V}(s_{min \perp})$  = Group factor for shear load, anchor group vertical to horizontal joint

fischer injection system FIS V Zero for masonry

**Intended use**  
Spacing and edge distance

**Annex B13**

Appendix 20 / 42

## Spacing and edge distance (continuation)

For  $s \geq s_{cr}$   $\alpha_g = 2$

For  $s_{min} \leq s < s_{cr}$   $\alpha_g$  according to installation parameters of brick Annex C

Group of 2 anchors

$$N_{RK}^{g} = \alpha_{g,N} \cdot N_{RK} ; \quad V_{RK,b}^{g} = V_{RK,c,II}^{g} = V_{RK,c,\perp}^{g} = \alpha_{g,V} \cdot V_{RK}$$

Group of 4 anchors

$$N_{RK}^{g} = \alpha_{g,N}(s_{minII}) \cdot \alpha_{g,N}(s_{min}^{\perp}) \cdot N_{RK} ;$$

$$V_{RK,b}^{g} = V_{RK,c,II}^{g} = V_{RK,c,\perp}^{g} = \alpha_{g,V}(s_{minII}) \cdot \alpha_{g,V}(s_{min}^{\perp}) \cdot V_{RK}$$

with  $N_{RK}$  and  $\alpha_{g,N}$  depending on  $s_{minII}$  or  $s_{min}^{\perp}$  acc. to Annex C

with  $V_{RK}$  and  $\alpha_{g,V}$  depending on  $s_{minII}$  or  $s_{min}^{\perp}$  acc. to Annex C

fischer injection system FIS V Zero for masonry

**Intended use**  
Spacing and edge distance (continuation)

**Annex B14**

Appendix 21 / 42

**Table C1.1: Characteristic resistance to steel failure of a single anchor under tension loading of fischer anchor rods and standard threaded rods**

Anchor rod / standard threaded rod		M8 <sup>3)</sup>	M10 <sup>3)</sup>	M12	M16	
<b>Characteristic resistance to steel failure under tension loading</b>						
Characteristic resistance $N_{Rk,s}$	Steel zinc plated	4.6	15(13)	23(21)	33	63
		4.8	15(13)	23(21)	33	63
		5.8	19(17)	29(27)	43	79
		8.8	29(27)	47(43)	68	126
	Stainless steel R and High corrosion resistant steel HCR	50	19	29	43	79
		70	26	41	59	110
		80	30	47	68	126

**Partial factors <sup>1)</sup>**

Partial factors $\gamma_{Ms,N}$	Steel zinc plated	4.6	[-]	2,00
		4.8		1,50
		5.8		1,50
		8.8		1,50
	Stainless steel R and High corrosion resistant steel HCR	50		2,86
		70		1,50 <sup>2)</sup> / 1,87
		80		1,60

<sup>1)</sup> In absence of other national regulations

<sup>2)</sup> Only for fischer anchor rod FIS A made of high corrosion-resistant steel HCR

<sup>3)</sup> Values in brackets are valid for undersized threaded rods with smaller stress area  $A_s$  for hot dip galvanised standard threaded rods according to EN ISO 10684:2004+AC:2009

fischer injection system FIS V Zero for masonry

**Performances**

Characteristic resistance to steel failure of a single anchor under tension loading of fischer anchor rods and standard threaded rods

**Annex C1**

Appendix 22 / 42



**Table C2.1:** Characteristic resistance to **steel failure** of a single anchor under **shear loading** with and without lever arm of **fischer anchor rods** and **standard threaded rods**

Anchor rod / standard threaded rod		M8 <sup>3)</sup>	M10 <sup>3)</sup>	M12	M16		
<b>Characteristic resistance to steel failure under shear loading</b>							
<b>without lever arm</b>							
Characteristic resistance $V_{Rk,s}$	Steel zinc plated	Property class	4.6	9(8)	14(13)	20	38
			4.8	9(8)	14(13)	20	38
		[kN]	5.8	11(10)	17(16)	25	47
			8.8	15(13)	23(21)	34	63
	Stainless steel R and High corrosion resistant steel HCR	Property class	50	9	15	21	39
			70	13	20	30	55
			80	15	23	34	63
<b>with lever arm</b>							
Characteristic resistance $M_{Rk,s}^0$	Steel zinc plated	Property class	4.6	15(13)	30(27)	52	133
			4.8	15(13)	30(27)	52	133
		[Nm]	5.8	19(16)	37(33)	65	166
			8.8	30(26)	60(53)	105	266
	Stainless steel R and High corrosion resistant steel HCR	Property class	50	19	37	65	166
			70	26	52	92	232
			80	30	60	105	266
<b>Partial factors <sup>1)</sup></b>							
Partial factors $\gamma_{Ms,V}$	Steel zinc plated	Property class	4.6	1,67			
			4.8	1,25			
		[-]	5.8	1,25			
			8.8	1,25			
	Stainless steel R and High corrosion resistant steel HCR	Property class	50	2,38			
			70	1,25 <sup>2)</sup> / 1,56			
			80	1,33			

<sup>1)</sup> In absence of other national regulations

<sup>2)</sup> Only for fischer anchor rod FIS A made of high corrosion-resistant steel HCR

<sup>3)</sup> Values in brackets are valid for undersized threaded rods with smaller stress area  $A_s$  for hot dip galvanised standard threaded rods (M8 resp. M10) according to EN ISO 10684:2004+AC:2009.

fischer injection system FIS V Zero for masonry

**Performances**

Characteristic resistance to steel failure of a single anchor under shear loading with and without lever arm of fischer anchor rods and standard threaded rods

**Annex C2**

Appendix 23 / 42

**Table C3.1: Characteristic resistance to steel failure of a single anchor under tension / shear loading of internal threaded anchors FIS E**

fischer internal threaded anchor FIS E				M8	M10	M12
<b>Characteristic resistance to steel failure under tension loading</b>						
Characteristic resistance with screw	$N_{Rk,s}$	Property class 5.8	[kN]	18	29	42
		R		26	41	59
		Property class 70 HCR		26	41	59
<b>Partial factors <sup>1)</sup></b>						
Partial factors	$\gamma_{Ms,N}$	Property class 5.8	[-]	1,50		
		R		1,87		
		Property class 70 HCR		1,87		
<b>Characteristic resistance to steel failure under shear loading</b>						
<b>without lever arm</b>						
Characteristic resistance with screw	$V_{Rk,s}$	Property class 5.8	[kN]	9	15	21
		R		13	20	30
		Property class 70 HCR		13	20	30
<b>with lever arm</b>						
Characteristic resistance	$M^0_{Rk,s}$	Property class 5.8	[Nm]	19	37	65
		R		26	52	92
		Property class 70 HCR		26	52	92
<b>Partial factors <sup>1)</sup></b>						
Partial factors	$\gamma_{Ms,V}$	Property class 5.8	[-]	1,25		
		R		1,56		
		Property class 70 HCR		1,56		

<sup>1)</sup> In absence of other national regulations

fischer injection system FIS V Zero for masonry	<b>Annex C3</b> Appendix 24 / 42
<b>Performances</b> Characteristic resistance to steel failure of a single anchor under tension / shear loading of internal threaded anchors FIS E	

# Solid brick Mz, EN 771-1: 2011+A1:2015

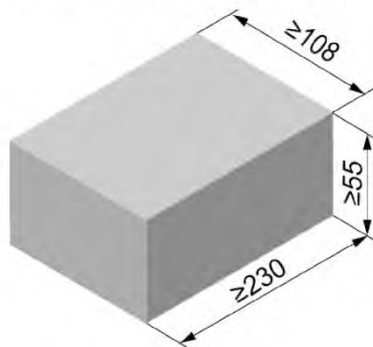

Solid brick Mz, EN 771-1: 2011+A1:2015			
Producer		e.g. Wienerberger	
Nominal dimensions [mm]	length L	width W	height H
	≥ 230	≥ 108	≥ 55
Mean gross dry density $\rho$ [kg/dm <sup>3</sup> ]	≥ 2,0		
Normalised mean compressive strength [N/mm <sup>2</sup> ]	36 / 48		
Standard	EN 771-1: 2011+A1:2015		

**Table C4.1: Installation parameters**

Anchor rod	M8	M10	M12	M16	-	-	
Internal threaded anchor FIS E	-	-	-	-	M8	M10   M12	
					11x85	15x85	
<b>Anchor rod and internal threaded anchor FIS E without perforated sleeve</b>							
Effective anchorage depth $h_{ef}$ [mm]	50	80	50	80	50	80	
Max. installation torque $\max T_{inst}$ [Nm]	10					10	
<b>General installation parameters</b>							
Edge distance $c_{min} = c_{cr}$	100						
Spacing	$s_{min \parallel}$	100					
	$s_{cr \parallel}$ [mm]	3 x $h_{ef}$					
	$s_{min \perp}$	100					
	$s_{cr \perp}$	3 x $h_{ef}$					
<b>Drilling method</b>							
Hole drilling with rotary drill mode or hammer drilling with hard metal hammer drill							

**Table C4.2: Group factors**

Anchor rods	M8	M10	M12	M16	-	-	
Internal threaded anchor FIS E	-	-	-	-	M8	M10   M12	
					11x85	15x85	
Group factors	$\alpha_{g,N} (s_{min \parallel})$	1,81					
	$\alpha_{g,V} (s_{min \parallel})$	1,49					
	$\alpha_{g,N} (s_{min \perp})$	1,74					
	$\alpha_{g,V} (s_{min \perp})$	1,49					

fischer injection system FIS V Zero for masonry

**Performances**  
Solid brick Mz, dimensions, installation parameters

**Annex C4**

Appendix 25 / 42

**Solid brick Mz, EN 771-1:2015**

**Table C5.1:** Characteristic resistance to pull-out failure or brick breakout failure of a single anchor under tension loading

Anchor rod	M8		M10		M12		M16		-	-
Internal threaded anchor FIS E	-		-		-		-		M8	M10   M12
	-		-		-		-		11x85	15x85
Tension resistance $N_{Rk} = N_{Rk,p} = N_{Rk,b} = N_{Rk,p,c} = N_{Rk,b,c}$ [kN] depending on the normalised mean compressive strength $f_b$ ; (temperature range 24/40°C)										
Normalised mean compressive strength $f_b$	Effective anchorage depth $h_{ef}$ [mm]									
	50	80	50	80	50	80	50	80	85	
36 N/mm <sup>2</sup>	2,5	3,0	3,0	3,0	3,0	3,0	3,0	4,5	2,5	
48 N/mm <sup>2</sup>	3,0	3,5	3,5	3,5	3,5	3,5	3,5	5,0	3,0	

**Tension resistance  $N_{Rk} = N_{Rk,p} = N_{Rk,b} = N_{Rk,p,c} = N_{Rk,b,c}$  [kN] depending on the normalised mean compressive strength  $f_b$  (temperature range 50/80°C and 72/120°C)**

Anchor rod	M8		M10		M12		M16		-	-
Internal threaded anchor FIS E	-		-		-		-		M8	M10   M12
	-		-		-		-		11x85	15x85
Tension resistance $N_{Rk} = N_{Rk,p} = N_{Rk,b} = N_{Rk,p,c} = N_{Rk,b,c}$ [kN] depending on the normalised mean compressive strength $f_b$ (temperature range 50/80°C and 72/120°C)										
Normalised mean compressive strength $f_b$	Effective anchorage depth $h_{ef}$ [mm]									
	50	80	50	80	50	80	50	80	85	
36 N/mm <sup>2</sup>	1,5	2,0	2,0	2,0	2,0	2,0	2,0	3,5	1,5	
48 N/mm <sup>2</sup>	1,5	2,5	2,5	2,5	2,5	2,5	2,5	4,0	1,5	

**Table C5.2:** Characteristic resistance to local brick failure or brick edge failure of a single anchor under shear loading

Anchor rod	M8		M10		M12		M16		-	-
Internal threaded anchor FIS E	-		-		-		-		M8	M10   M12
	-		-		-		-		11x85	15x85
Shear resistance $V_{Rk} = V_{Rk,b} = V_{Rk,c,II} = V_{Rk,c,I}$ [kN] depending on the normalised mean compressive strength $f_b$ ; (temperature range 24/40°C, 50/80°C and 72/120°C)										
Normalised mean compressive strength $f_b$	Effective anchorage depth $h_{ef}$ [mm]									
	50	80	50	80	50	80	50	80	85	
36 N/mm <sup>2</sup>	2,5	4,5	2,5	4,5	2,5	4,5	2,5	4,5	2,5	2,5
48 N/mm <sup>2</sup>	3,0	5,0	3,0	5,0	3,0	5,0	3,0	5,0	3,0	3,0

Factor for job site tests see annex C20 and displacements see annex C21

fischer injection system FIS V Zero for masonry	<b>Annex C5</b> Appendix 26 / 42
<b>Performances</b> Solid brick Mz, Characteristic resistance under tension and shear loading	

# Solid calcium silicate (sand-lime) brick KS, NF, EN 771-2: 2011+A1:2015

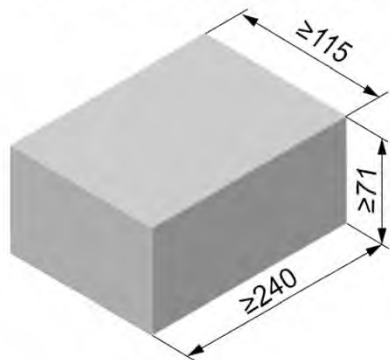

Solid calcium silicate (sand-lime) brick KS, NF, EN 771-2: 2011+A1:2015			
Producer	---		
Nominal dimensions [mm]	length L	width W	height H
	≥ 240	≥ 115	≥ 71
Mean gross dry density [kg/dm <sup>3</sup> ]	≥ 2,0		
Normalised mean compressive strength [N/mm <sup>2</sup> ]	12 / 16 / 20		
Standard	EN 771-2: 2011+A1:2015		

**Table C6.1: Installation parameters**

Anchor rod	M8		M10		M12		M16		-	-		
Internal threaded anchor FIS E	-		-		-		-		M8	M10	M12	
	-		-		-		-		11x85	15x85		
<b>Anchor rod and internal threaded anchor FIS E without perforated sleeve</b>												
Effective anchorage depth $h_{ef}$ [mm]	50	80	50	80	50	80	50	80	85	85		
Max. installation torque $\max T_{inst}$ [Nm]	8				10				8	10		
<b>General installation parameters</b>												
Edge distance $c_{min} = c_{cr}$	100											
Spacing	$s_{min \parallel}$	100										
	$s_{cr \parallel}$	3 x $h_{ef}$										
	$s_{min \perp}$	100										
	$s_{cr \perp}$	3 x $h_{ef}$										
<b>Drilling method</b>												
Hole drilling with rotary drill mode or hammer drilling with hard metal hammer drill												

**Table C6.2: Group factors**

Anchor rod	M8		M10		M12		M16		-	-	
Internal threaded anchor FIS E	-		-		-		-		M8	M10	M12
	-		-		-		-		11x85	15x85	
Group factors	$\alpha_{g,N} (s_{min \parallel})$	1,67									
	$\alpha_{g,V} (s_{min \parallel})$	1,26									
	$\alpha_{g,N} (s_{min \perp})$	1,67									
	$\alpha_{g,V} (s_{min \perp})$	2,0									

fischer injection system FIS V Zero for masonry

**Performances**

Solid calcium silicate (sand-lime) brick KS, NF, dimensions, installation parameters

**Annex C6**

# Solid calcium silicate (sand-lime) brick KS, NF, EN 771-2: 2011+A1:2015

**Table C7.1:** Characteristic resistance to pull-out failure or brick breakout failure of a single anchor under tension loading

Anchor rod	M8		M10		M12		M16		-	-
Internal threaded anchor FIS E	-		-		-		-		M8	M10   M12
	-		-		-		-		11x85	15x85
Tension resistance $N_{Rk} = N_{Rk,p} = N_{Rk,b} = N_{Rk,p,c} = N_{Rk,b,c}$ [kN] depending on the normalised mean compressive strength $f_b$ ; (temperature range 24/40°C)										
Normalised mean compressive strength $f_b$	Effective anchorage depth $h_{ef}$ [mm]									
	50	80	50	80	50	80	50	80	85	85
12 N/mm <sup>2</sup>	2,0	2,0	2,5	4,5	2,0	4,5	2,0	2,0	2,0	
16 N/mm <sup>2</sup>	2,5	2,5	2,5	5,0	2,5	5,0	2,5	2,5	2,5	
20 N/mm <sup>2</sup>	2,5	3,0	3,0	6,0	2,5	6,0	2,5	3,0	2,5	

**Table C7.2:** Characteristic resistance to local brick failure or brick edge failure of a single anchor under shear loading

Anchor rod	M8		M10		M12		M16		-	-
Internal threaded anchor FIS E	-		-		-		-		M8	M10   M12
	-		-		-		-		11x85	15x85
Shear resistance $V_{Rk} = V_{Rk,b} = V_{Rk,c,II} = V_{Rk,c,I}$ [kN] depending on the normalised mean compressive strength $f_b$ ; (temperature range 24/40°C, 50/80°C and 72/120°C)										
Normalised mean compressive strength $f_b$	Effective anchorage depth $h_{ef}$ [mm]									
	50	80	50	80	50	80	50	80	85	85
12 N/mm <sup>2</sup>	1,5	1,5	1,5	3,0	1,5	3,0	1,5	1,5	1,5	
16 N/mm <sup>2</sup>	1,5	1,5	2,0	3,5	1,5	3,5	1,5	1,5	1,5	
20 N/mm <sup>2</sup>	2,0	2,0	2,0	4,0	2,0	4,0	2,0	2,0	2,0	

**Table C7.2:** Characteristic resistance to local brick failure or brick edge failure of a single anchor under shear loading

Anchor rod	M8		M10		M12		M16		-	-
Internal threaded anchor FIS E	-		-		-		-		M8	M10   M12
	-		-		-		-		11x85	15x85
Shear resistance $V_{Rk} = V_{Rk,b} = V_{Rk,c,II} = V_{Rk,c,I}$ [kN] depending on the normalised mean compressive strength $f_b$ ; (temperature range 24/40°C, 50/80°C and 72/120°C)										
Normalised mean compressive strength $f_b$	Effective anchorage depth $h_{ef}$ [mm]									
	50	80	50	80	50	80	50	80	85	85
12 N/mm <sup>2</sup>	3,5	3,5	4,5	4,5	3,5	4,0	3,5	4,0	3,5	3,5
16 N/mm <sup>2</sup>	4,0	4,0	5,0	5,0	4,0	4,5	4,0	4,5	4,0	4,0
20 N/mm <sup>2</sup>	4,5	4,5	6,0	6,0	4,5	5,0	4,5	5,0	4,5	4,5

Factor for job site tests see annex C20 and displacements see annex C21

fischer injection system FIS V Zero for masonry

**Performances**  
Solid calcium silicate (sand-lime) brick KS, NF, Characteristic resistance under tension and shear loading

**Annex C7**

Appendix 28 / 42

# Perforated calcium silicate (sand-lime) brick KSL, 3DF, EN 771-2: 2011+A1:2015

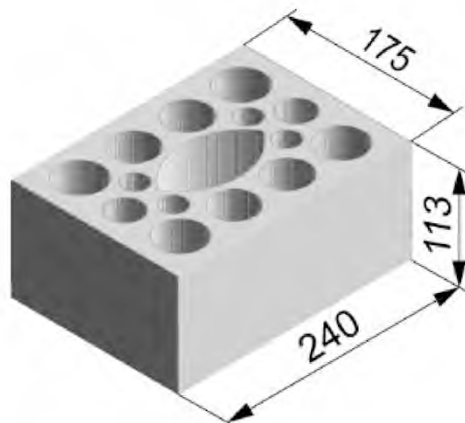

Perforated calcium silicate (sand-lime) brick KSL, 3DF, EN 771-2: 2011+A1:2015			
Producer		e.g. KS Wemding	
Nominal dimensions [mm]		length L	width W
		240	175
Mean gross dry density $\rho$ [kg/dm <sup>3</sup> ]		≥ 1,6	
Normalised mean compressive strength [N/mm <sup>2</sup> ]		6 / 8 / 10 / 12 / 16	
Standard		EN 771-2: 2011+A1:2015	

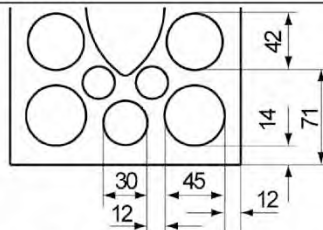

Dimensions see also Annex B12

**Table C8.1:** Installation parameters  
(Pre-positioned installation with perforated sleeve FIS H K)

Anchor rod	M8	M8	-	M8	M10	M8	M10	-	M12	M16	M12	M16	
Internal threaded anchor FIS E	-	-	M8	-	-	-	-	M10	M12	-	-	-	
			11x85					15x85					
Perforated sleeve FIS H K	12x50	12x85	16x85		16x130		20x85			20x130			
Anchor rod and internal threaded anchor FIS E with perforated sleeve FIS H K													
Max. installation torque max $T_{inst}$ [Nm]	8	8	8	8	10	8	10	10					
<b>General installation parameters</b>													
Edge distance $c_{min} = c_{cr}$							100						
Spacing	$s_{min \parallel}$							100					
	$s_{scr \parallel}$ [mm]							240					
	$s_{min \perp}$							100					
	$s_{scr \perp}$							115					
<b>Drilling method</b>													
Hole drilling with rotary drill mode or hammer drilling with hard metal hammer drill													

**Table C8.2:** Group factors

Anchor rod	M8	M8	-	M8	M10	M8	M10	-	M12	M16	M12	M16	
Internal threaded anchor FIS E	-	-	M8	-	-	-	-	M10	M12	-	-	-	
			11x85					15x85					
Perforated sleeve FIS H K	12x50	12x85	16x85		16x130		20x85			20x130			
Group factors	$\alpha_{g,N} (s_{min \parallel})$	[-]						1,14					
	$\alpha_{g,V} (s_{min \parallel})$							1,51					
	$\alpha_{g,N} (s_{min \perp})$							1,14					
	$\alpha_{g,V} (s_{min \perp})$							1,54					

fischer injection system FIS V Zero for masonry

**Performances**

Perforated calcium silicate (sand-lime) brick KSL, 3DF, dimensions, installation parameters

**Annex C8**

**Perforated calcium silicate (sand-lime) brick KSL, 3DF, EN 771-2: 2011+A1:2015**

**Table C9.1:** Installation parameters  
(Push through installation with perforated sleeve FIS H K)

Anchor rod		M10	M12	M16
Perforated sleeve FIS H K		18x130/200		22x130/200
<b>Anchor rod with perforated sleeve FIS H K</b>				
Max. installation torque	max $T_{inst}$ [Nm]	10		
<b>General installation parameters</b>				
Edge distance	$c_{min} = c_{cr}$	100		
Spacing	$s_{min \parallel}$	100		
	$s_{cr \parallel}$ [mm]	240		
	$s_{min \perp}$	100		
	$s_{cr \perp}$	115		

**Drilling method**

Hole drilling with rotary drill mode or hammer drilling with hard metal hammer drill

**Table C9.2:** Group factors

Anchor rod		M10	M12	M16
Perforated sleeve FIS H K		18x130/200		22x130/200
Group factors	$\alpha_{g,N} (s_{min \parallel})$	1,14		
	$\alpha_{g,V} (s_{min \parallel})$	1,51		
	$\alpha_{g,N} (s_{min \perp})$	1,14		
	$\alpha_{g,V} (s_{min \perp})$	1,54		

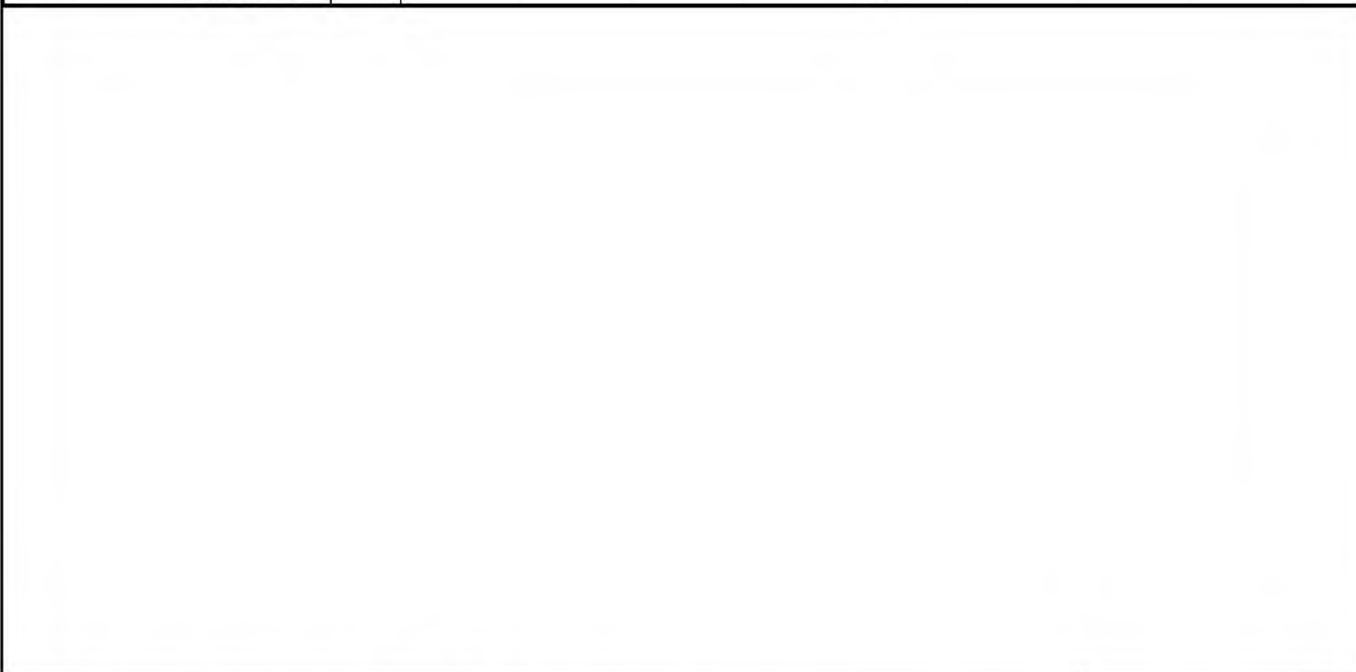

fischer injection system FIS V Zero for masonry	<b>Annex C9</b> Appendix 30 / 42
<b>Performances</b> Perforated calcium silicate (sand-lime) brick KSL, 3DF, dimensions, installation parameters	



**Perforated calcium silicate (sand-lime) brick KSL, 3DF, EN 771-2: 2011+A1:2015**

**Table C10.1:** Characteristic resistance to pull-out failure or brick breakout failure of a single anchor under tension loading (Pre-positioned installation)

Anchor rod	M8	M8	-	M8	M10	M8	M10	-	M12	M16	M12	M16
Internal threaded anchor FIS E	-	-	M8	-	-	-	M10	M12	-	-	-	-
			11x85				15x85					
Perforated sleeve FIS H K	12x50	12x85	16x85		16x130		20x85			20x130		

**Tension resistance  $N_{Rk} = N_{Rk,p} = N_{Rk,b} = N_{Rk,p,c} = N_{Rk,b,c}$  [kN] depending on the normalised mean compressive strength  $f_b$ ; (temperature range 24/40°C)**

Norm. mean compressive strength $f_b$								
6 N/mm <sup>2</sup>	1,2		0,9		2,0		0,9	2,0
8 N/mm <sup>2</sup>	1,5		1,2		2,5		1,2	2,5
10 N/mm <sup>2</sup>	1,5		1,5		3,0		1,5	3,0
12 N/mm <sup>2</sup>	2,0		1,5		3,5		1,5	3,5
16 N/mm <sup>2</sup>	2,5		2,0		4,5		2,0	4,5

**Tension resistance  $N_{Rk} = N_{Rk,p} = N_{Rk,b} = N_{Rk,p,c} = N_{Rk,b,c}$  [kN] depending on the normalised mean compressive strength  $f_b$ ; (temperature range 50/80°C and 72/120°C)**

Norm. mean compressive strength $f_b$								
6 N/mm <sup>2</sup>	0,6		0,75		1,5		0,75	1,5
8 N/mm <sup>2</sup>	0,75		0,9		2,0		0,9	2,0
10 N/mm <sup>2</sup>	0,9		0,9		2,5		0,9	2,5
12 N/mm <sup>2</sup>	0,9		1,2		2,5		1,2	2,5
16 N/mm <sup>2</sup>	1,2		1,5		3,5		1,5	3,5

**Table C10.2:** Characteristic resistance to pull-out failure or brick breakout failure of a single anchor under tension loading (Push through installation)

Anchor rod	M10	M12	M16
Perforated sleeve FIS H K	18x130/200		22x130/200

**Tension resistance  $N_{Rk} = N_{Rk,p} = N_{Rk,b} = N_{Rk,p,c} = N_{Rk,b,c}$  [kN] depending on the normalised mean compressive strength  $f_b$ ; (temperature range 24/40°C)**

Norm. mean compressive strength $f_b$				
6 N/mm <sup>2</sup>			2,0	
8 N/mm <sup>2</sup>			2,5	
10 N/mm <sup>2</sup>			3,0	
12 N/mm <sup>2</sup>			3,5	
16 N/mm <sup>2</sup>			4,5	

**Tension resistance  $N_{Rk} = N_{Rk,p} = N_{Rk,b} = N_{Rk,p,c} = N_{Rk,b,c}$  [kN] depending on the normalised mean compressive strength  $f_b$ ; (temperature range 50/80°C and 72/120°C)**

Norm. mean compressive strength $f_b$				
6 N/mm <sup>2</sup>			1,5	
8 N/mm <sup>2</sup>			2,0	
10 N/mm <sup>2</sup>			2,5	
12 N/mm <sup>2</sup>			2,5	
16 N/mm <sup>2</sup>			3,5	

Factor for job site tests see annex C20 and displacements see annex C21

fischer injection system FIS V Zero for masonry	<b>Annex C10</b> Appendix 31 / 42
<b>Performances</b> Perforated calcium silicate (sand-lime) brick KSL, 3DF, Characteristic resistance under tension loading	

**Perforated calcium silicate (sand-lime) brick KSL, 3DF, EN 771-2: 2011+A1:2015**

**Table C11.1:** Characteristic resistance to local brick failure or brick edge failure of a single anchor under shear loading (Pre-positioned installation)

Anchor rod	M8	M8	-	M8	M10	M8	M10	-	M12	M16	M12	M16
Internal threaded anchor FIS E	-	-	M8	-	-	-	-	M10	M12	-	-	-
			11x85					15x85				
Perforated sleeve FIS H K	12x50	12x85	16x85		16x130		20x85			20x130		
<b>Shear resistance <math>V_{Rk} = V_{Rk,b} = V_{Rk,c,II} = V_{Rk,c,\perp}</math> [kN] depending on the normalised mean compressive strength <math>f_b</math>; (temperature range 24/40°C, 50/80°C and 72/120°C)</b>												
Normalised mean compressive strength $f_b$												
6 N/mm <sup>2</sup>	1,5				2,0					3,0		
8 N/mm <sup>2</sup>	2,0				2,5					3,5		
10 N/mm <sup>2</sup>	2,5				3,0					4,5		
12 N/mm <sup>2</sup>	2,5				3,5					5,0		
16 N/mm <sup>2</sup>	3,5				4,0					6,5		

**Table C11.2:** Characteristic resistance to local brick failure or brick edge failure of a single anchor under shear loading (Push through installation)

Anchor rod	M10	M12	M16
Perforated sleeve FIS H K	18x130/200		22x130/200
<b>Shear resistance <math>V_{Rk} = V_{Rk,b} = V_{Rk,c,II} = V_{Rk,c,\perp}</math> [kN] depending on the normalised mean compressive strength <math>f_b</math>; (temperature range 24/40°C, 50/80°C and 72/120°C)</b>			
Normalised mean compressive strength $f_b$			
6 N/mm <sup>2</sup>	2,0		3,0
8 N/mm <sup>2</sup>	2,5		3,5
10 N/mm <sup>2</sup>	3,0		4,5
12 N/mm <sup>2</sup>	3,5		5,0
16 N/mm <sup>2</sup>	4,0		6,5

Factor for job site tests see annex C20 and displacements see annex C21

fischer injection system FIS V Zero for masonry

**Performances**

Perforated calcium silicate (sand-lime) brick KSL, 3DF, Characteristic resistance under shear loading

**Annex C11**

# Vertical perforated brick HLz, EN 771-1: 2011+A1:2015

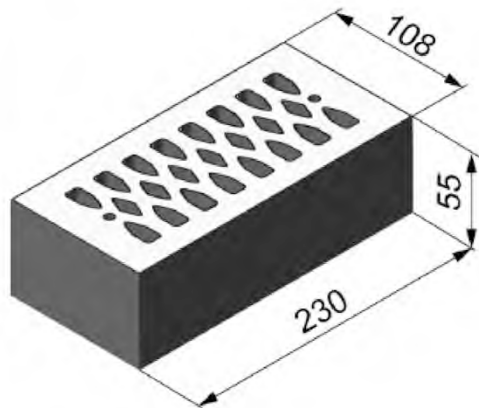

Vertical perforated brick HLz, EN 771-1: 2011+A1:2015			
Producer		e.g. Wienerberger.	
Nominal dimensions [mm]	length L	width W	height H
	230	108	55
Mean gross dry density $\rho$ [kg/dm <sup>3</sup> ]	≥ 1,6		
Normalised mean compressive strength [N/mm <sup>2</sup> ]	8 / 10 / 12 / 16		
Standard	EN 771-1: 2011+A1:2015		

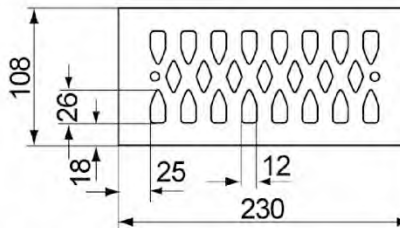

Dimensions see also Annex B12

**Table C12.1: Installation parameters**

<b>Anchor rod</b>	<b>M8</b>	<b>M8</b>	<b>-</b>	<b>M8</b>	<b>M10</b>	<b>M8</b>	<b>M10</b>	<b>-</b>	<b>M12</b>	<b>M16</b>	<b>M12</b>	<b>M16</b>
<b>Internal threaded anchor FIS E</b>	-	-	<b>M8</b>	-	-	-	-	<b>M10</b>	<b>M12</b>	-	-	-
			<b>11x85</b>					<b>15x85</b>				
<b>Perforated sleeve FIS H K</b>	<b>12x50</b>	<b>12x85</b>	<b>16x85</b>		<b>16x130</b>		<b>20x85</b>		<b>20x130</b>			
<b>Anchor rod and internal threaded anchor FIS E with perforated sleeve FIS H K</b>												
Max. installation torque	max $T_{inst}$	[Nm]	5									
<b>General installation parameters</b>												
Edge distance	$c_{min} = c_{cr}$		100									
Spacing	$s_{min II}$		100									
	$s_{scr II}$	[mm]	230									
	$s_{min \perp}$		60									
	$s_{scr \perp}$		60									
<b>Drilling method</b>												
Hole drilling with rotary drill mode or hammer drilling with hard metal hammer drill												

**Table C12.2: Group factors**

<b>Anchor rod</b>	<b>M8</b>	<b>M8</b>	<b>-</b>	<b>M8</b>	<b>M10</b>	<b>M8</b>	<b>M10</b>	<b>-</b>	<b>M12</b>	<b>M16</b>	<b>M12</b>	<b>M16</b>
<b>Internal threaded anchor FIS E</b>	-	-	<b>M8</b>	-	-	-	-	<b>M10</b>	<b>M12</b>	-	-	-
			<b>11x85</b>					<b>15x85</b>				
<b>Perforated sleeve FIS H K</b>	<b>12x50</b>	<b>12x85</b>	<b>16x85</b>		<b>16x130</b>		<b>20x85</b>		<b>20x130</b>			
Group factors	$\alpha_{g,N} (s_{min II})$	[-]	1,65									
	$\alpha_{g,V} (s_{min II})$		1,64									
	$\alpha_{g,N} (s_{min \perp})$		1,65									
	$\alpha_{g,V} (s_{min \perp})$		2,00									

fischer injection system FIS V Zero for masonry

**Performances**

Vertical perforated brick HLz, dimensions, installation parameters

**Annex C12**

Appendix 33 / 42

## Vertical perforated brick HLz, EN 771-1: 2011+A1:2015

**Table C13.1:** Characteristic resistance to pull-out failure or brick breakout failure of a single anchor under tension loading

Anchor rod	M8	M8	-	M8	M10	M8	M10	-	M12	M16	M12	M16
Internal threaded anchor FIS E	-	-	M8	-	-	-	-	M10	M12	-	-	-
			11x85					15x85				
Perforated sleeve FIS H K	12x50	12x85	16x85		16x130		20x85			20x130		
Tension resistance $N_{Rk} = N_{Rk,p} = N_{Rk,b} = N_{Rk,p,c} = N_{Rk,b,c}$ [kN] depending on the normalised mean compressive strength $f_b$ ; (temperature range 24/40°C)												
Normalised mean compressive strength $f_b$												
8 N/mm <sup>2</sup>	1,2	1,5	1,5		2,5		1,5			2,5		
10 N/mm <sup>2</sup>	1,2	2,0	2,0		2,5		2,0			2,5		
12 N/mm <sup>2</sup>	1,5	2,0	2,0		3,0		2,0			3,0		
16 N/mm <sup>2</sup>	1,5	2,5	2,5		3,5		2,5			3,5		
Tension resistance $N_{Rk} = N_{Rk,p} = N_{Rk,b} = N_{Rk,p,c} = N_{Rk,b,c}$ [kN] depending on the normalised mean compressive strength $f_b$ ; (temperature range 50/80°C and 72/120°C)												
Normalised mean compressive strength $f_b$												
8 N/mm <sup>2</sup>	0,6	1,2	1,2		1,5		1,2			1,5		
10 N/mm <sup>2</sup>	0,75	1,2	1,2		2,0		1,2			2,0		
12 N/mm <sup>2</sup>	0,75	1,5	1,5		2,0		1,5			2,0		
16 N/mm <sup>2</sup>	0,9	1,5	1,5		2,5		1,5			2,5		

**Table C13.2:** Characteristic resistance to local brick failure or brick edge failure of a single anchor under shear loading

Anchor rod	M8	M8	-	M8	M10	M8	M10	-	M12	M16	M12	M16
Internal threaded anchor FIS E	-	-	M8	-	-	-	-	M10	M12	-	-	-
			11x85					15x85				
Perforated sleeve FIS H K	12x50	12x85	16x85		16x130		20x85			20x130		
Shear resistance $V_{Rk} = V_{Rk,b} = V_{Rk,c,II} = V_{Rk,c,I}$ [kN] depending on the normalised mean compressive strength $f_b$ ; (temperature range 24/40°C, 50/80°C and 72/120°C)												
Normalised mean compressive strength $f_b$												
8 N/mm <sup>2</sup>	2,0	3,5	2,5		3,5		2,5			3,5		
10 N/mm <sup>2</sup>	2,0	4,0	3,0		4,0		3,0			4,0		
12 N/mm <sup>2</sup>	2,0	4,0	3,0		4,5		3,0			4,5		
16 N/mm <sup>2</sup>	2,5	5,0	3,5		5,0		3,5			5,0		

Factor for job site tests see annex C20 and displacements see annex C21

fischer injection system FIS V Zero for masonry	<b>Annex C13</b> Appendix 34 / 42
<b>Performances</b> Vertical perforated brick HLz, Characteristic resistance under tension and shear loading	

# Lightweight aggregate concrete hollow block Hbl , EN 771-3: 2011+A1:2015

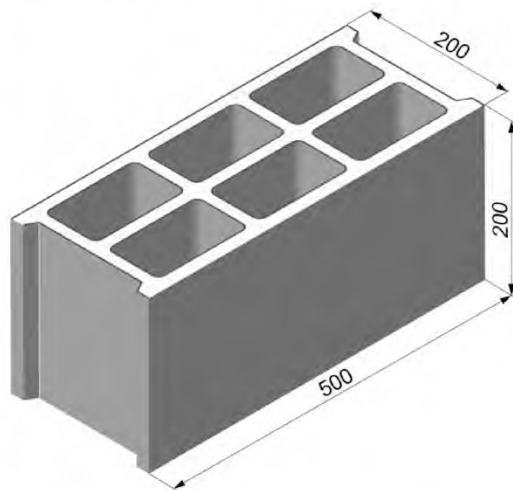

Lightweight aggregate concrete hollow block Hbl, EN 771-3: 2011+A1:2015			
Producer		e.g. Sepa	
Nominal dimensions [mm]	length L	width W	height H
	500	200	200
Mean gross dry density $\rho$ [kg/dm <sup>3</sup> ]	≥ 1,0		
Normalised mean compressive strength [N/mm <sup>2</sup> ]	2 / 4		
Standard		EN 771-1: 2011+A1:2015	

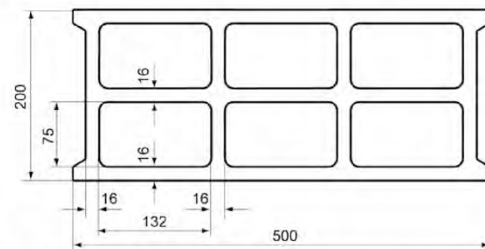

Dimensions see also Annex B12

**Table C14.1: Installation parameters**

<b>Anchor rod</b>	-	M8	M10	M8	M10	M10	M12	-	M12	M16	M12	M16
<b>Internal threaded anchor FIS E</b>	M8	-	-	-	-	-	-	M10	M12	-	-	-
	11x85	-	-	-	-	-	-	15x85	-	-	-	-
<b>Perforated sleeve FIS H K</b>	16x85		16x130		18x130/200		20x85			20x130		
<b>Anchor rod and internal threaded anchor FIS E with perforated sleeve FIS H K</b>												
Max. installation torque	max T <sub>inst</sub> [Nm]	2										
<b>General installation parameters</b>												
Edge distance	C <sub>min</sub> = C <sub>cr</sub>	100										
Spacing	S <sub>min</sub>	100										
	S <sub>cr</sub>    [mm]	500										
	S <sub>min</sub> ⊥	100										
	S <sub>cr</sub> ⊥	200										
<b>Drilling method</b>												
Hole drilling with rotary drill mode or hammer drilling with hard metal hammer drill												

**Table C14.2: Group factors**

<b>Anchor rod</b>	-	M8	M10	M8	M10	M10	M12	-	M12	M16	M12	M16
<b>Internal threaded anchor FIS E</b>	M8	-	-	-	-	-	-	M10	M12	-	-	-
	11x85	-	-	-	-	-	-	15x85	-	-	-	-
<b>Perforated sleeve FIS H K</b>	16x85		16x130		18x130/200		20x85			20x130		
Group factors	$\alpha_{g,N} (S_{min}   )$	2,00										
	$\alpha_{g,V} (S_{min}   )$	1,28										
	$\alpha_{g,N} (S_{min} \perp)$	1,40										
	$\alpha_{g,V} (S_{min} \perp)$	2,00										

fischer injection system FIS V Zero for masonry

**Performances**

Lightweight aggregate concrete hollow block Hbl, dimensions, installation parameters

**Annex C14**

Appendix 35 / 42

# Lightweight aggregate concrete hollow block Hbl, EN 771-3: 2011+A1:2015

**Table C15.1:** Characteristic resistance to pull-out failure or brick breakout failure of a single anchor under tension loading

Anchor rod	-	M8	M10	M8	M10	M10	M12	-	M12	M16	M12	M16
Internal threaded anchor FIS E	M8							M10	M12			
	11x85	-	-	-	-	-	-	15x85	-	-	-	-
Perforated sleeve FIS H K	16x85		16x130		18x130/200		20x85			20x130		

Tension resistance  $N_{Rk} = N_{Rk,p} = N_{Rk,b} = N_{Rk,p,c} = N_{Rk,b,c}$  [kN] depending on the normalised mean compressive strength  $f_b$ ; (temperature range 24/40°C)

Normalised mean compressive strength $f_b$											
2 N/mm <sup>2</sup>	0,4										0,6
4 N/mm <sup>2</sup>	0,5										0,75

Tension resistance  $N_{Rk} = N_{Rk,p} = N_{Rk,b} = N_{Rk,p,c} = N_{Rk,b,c}$  [kN] depending on the normalised mean compressive strength  $f_b$ ; (temperature range 50/80°C and 72/120°C)

Normalised mean compressive strength $f_b$											
2 N/mm <sup>2</sup>	0,3										0,5
4 N/mm <sup>2</sup>	0,4										0,6

**Table C15.2:** Characteristic resistance to local brick failure or brick edge failure of a single anchor under shear loading

Anchor rod	-	M8	M10	M8	M10	M10	M12	-	M12	M16	M12	M16
Internal threaded anchor FIS E	M8							M10	M12			
	11x85	-	-	-	-	-	-	15x85	-	-	-	-
Perforated sleeve FIS H K	16x85		16x130		18x130/200		20x85			20x130		

Shear resistance  $V_{Rk} = V_{Rk,b} = V_{Rk,c,II} = V_{Rk,c,\perp}$  [kN] depending on the normalised mean compressive strength  $f_b$ ; (temperature range 24/40°C, 50/80°C and 72/120°C)

Normalised mean compressive strength $f_b$											
2 N/mm <sup>2</sup>	1,5										
4 N/mm <sup>2</sup>	2,0										

Factor for job site tests see annex C20 and displacements see annex C21

fischer injection system FIS V Zero for masonry	<b>Annex C15</b> Appendix 36 / 42
<b>Performances</b> Lightweight aggregate concrete hollow block Hbl Characteristic resistance under tension and shear loading	

# Autoclaved aerated concrete (cylindrical drill hole), EN 771-4:2011+A1:2015



Producer		e.g. Ytong		
Mean gross dry density $\rho$	[kg/dm <sup>3</sup> ]	0,35	0,5	0,65
Mean compressive strength / Min. compressive strength single brick <sup>1)</sup>	[N/mm <sup>2</sup> ]	2,5 / 2	5 / 4	8 / 6
Standard or annex		EN 771-4:2011+A1:2015		

**Table C16.1: Installation parameters**

Anchor rod		M8	M10	M12	M16
Internal threaded anchor FIS E		-	-	-	-
<b>Anchor rod and internal threaded anchor FIS E without perforated sleeve</b>					
Effective anchorage depth	$h_{ef}$ [mm]	100	100	100	100
Max. installation torque	$\max T_{inst}$ [Nm]	2	2	2	2
<b>General installation parameters</b>					
Edge distance	$c_{min}$	100			
	$c_{cr}$	250			
Spacing	$s_{cr \parallel}$	250			
	$s_{min \parallel}$	100			
	$s_{cr \perp}$	250			
	$s_{min \perp}$	100			

### Drilling method

Hammer drilling with hard metal hammer drill

<sup>1)</sup> The compressive strength of the single brick must not be less than 80% of the mean compressive strength.

fischer injection system FIS V Zero for masonry

### Performance

Autoclaved aerated concrete (cylindrical drill hole), dimensions, installation parameters

**Annex C16**

Appendix 37 / 42

<b>Table C17.1: Group factors for autoclaved aerated concrete</b> (Min. compressive strength single brick 2 N/mm <sup>2</sup> )					
<b>Anchor rod</b>		<b>M8</b>	<b>M10</b>	<b>M12</b>	<b>M16</b>
<b>Groupfactors</b>	$\alpha_{g,N \parallel}, (S_{min \parallel})$	[-]	1,13		
	$\alpha_{g,N \perp}, (S_{min \perp})$		1,20		
	$\alpha_{g,V}, (S_{min \parallel})$		1,39		
	$\alpha_{g,V}, (S_{min \perp})$		1,17		

<b>Table C17.2: Group factors for autoclaved aerated concrete</b> (Min. compressive strength single brick 4 N/mm <sup>2</sup> )					
<b>Anchor rod</b>		<b>M8</b>	<b>M10</b>	<b>M12</b>	<b>M16</b>
<b>Groupfactors</b>	$\alpha_{g,N \parallel}, (S_{min \parallel})$	[-]	1,13		
	$\alpha_{g,N \perp}, (S_{min \perp})$		1,20		
	$\alpha_{g,V}, (S_{min \parallel})$		1,39		
	$\alpha_{g,V}, (S_{min \perp})$		1,17		

<b>Table C17.3: Group factors for autoclaved aerated concrete</b> (Min. compressive strength single brick 6 N/mm <sup>2</sup> )					
<b>Anchor rod</b>		<b>M8</b>	<b>M10</b>	<b>M12</b>	<b>M16</b>
<b>Groupfactors</b>	$\alpha_{g,N \parallel}, (S_{min \parallel})$	[-]	1,13		
	$\alpha_{g,N \perp}, (S_{min \perp})$		1,20		
	$\alpha_{g,V}, (S_{min \parallel})$		1,39		
	$\alpha_{g,V}, (S_{min \perp})$		1,17		

--	--	--	--	--

<b>fischer injection system FIS V Zero for masonry</b>				<b>Annex C17</b>  Appendix 38 / 42
<b>Performance</b> Autoclaved aerated concrete (cylindrical drill hole), Group factors				



# Autoclaved aerated concrete (cylindrical drill hole), EN 771-4:2011+A1:2015

**Table C18.1:** Characteristic resistance to pull-out failure or brick breakout failure of a single anchor under tension loading

Anchor rod		M8	M10	M12	M16
<b>Tension resistance <math>N_{Rk} = N_{Rk,p} = N_{Rk,b} = N_{Rk,p,c} = N_{Rk,b,c}</math> [kN] depending on the mean compressive strength / Min. compressive strength single brick; (temperature range 24/40°)</b>					
Mean compressive strength / Min. compressive strength single brick <sup>1)</sup>	Use conditions	Effective anchorage depth $h_{ef}$ [mm]			
		100	100	100	100
<b>2,5 / 2 N/mm<sup>2</sup></b>	d/d	1,2	1,2	1,2	1,5
<b>5 / 4 N/mm<sup>2</sup></b>	d/d	1,2	1,2	1,2	1,5
<b>8 / 6 N/mm<sup>2</sup></b>	d/d	1,2	1,2	1,2	1,5

Anchor rod		M8	M10	M12	M16
<b>Tension resistance <math>N_{Rk} = N_{Rk,p} = N_{Rk,b} = N_{Rk,p,c} = N_{Rk,b,c}</math> [kN] depending on the mean compressive strength / Min. compressive strength single brick; (temperature range 50/80°C)</b>					
Mean compressive strength / Min. compressive strength single brick <sup>1)</sup>	Use conditions	Effective anchorage depth $h_{ef}$ [mm]			
		100	100	100	100
<b>2,5 / 2 N/mm<sup>2</sup></b>	d/d	0,9	0,9	1,2	1,5
<b>5 / 4 N/mm<sup>2</sup></b>	d/d	0,9	0,9	1,2	1,5
<b>8 / 6 N/mm<sup>2</sup></b>	d/d	0,9	0,9	1,2	1,5

<sup>1)</sup> The compressive strength of the single brick must not be less than 80% of the mean compressive strength.

fischer injection system FIS V Zero for masonry	<b>Annex C18</b> Appendix 39 / 42
<b>Performance</b> Autoclaved aerated concrete (cylindrical drill hole), Characteristic resistance under tension loading	

**Table C19.1:** Characteristic resistance to local brick failure or brick edge failure of a single anchor under shear loading

Anchor rod		M8	M10	M12	M16
Internal threaded anchor FIS E		-	-	-	-
<b>Shear resistance <math>V_{Rk} = V_{Rk,b} = V_{Rk,c,II} = V_{Rk,c,\perp}</math> [kN] depending on the mean compressive strength / Min. compressive strength single brick; (temperature range 24/40°C and 50/80°C) <math>c_{min} \geq 100mm</math></b>					
Mean compressive strength / Min. compressive strength single brick <sup>1)</sup>	Use conditions	Effective anchorage depth $h_{ef}$ [mm]			
		100	100	100	100
2,5 / 2 N/mm <sup>2</sup>	d/d	1,2	1,2	1,2	1,2
5 / 4 N/mm <sup>2</sup>	d/d	1,2	1,2	1,2	1,2
8 / 6 N/mm <sup>2</sup>	d/d	1,2	1,2	1,2	1,2
Anchor rod		M8	M10	M12	M16
Internal threaded anchor FIS E		-	-	-	-
<b>Shear resistance <math>V_{Rk} = V_{Rk,b} = V_{Rk,c,II} = V_{Rk,c,\perp}</math> [kN] depending on the mean compressive strength / Min. compressive strength single brick; (temperature range 24/40°C and 50/80°C) <math>c_{cr} &gt; 250mm</math></b>					
Mean compressive strength / Min. compressive strength single brick <sup>1)</sup>	Use conditions	Effective anchorage depth $h_{ef}$ [mm]			
		100	100	100	100
2,5 / 2 N/mm <sup>2</sup>	d/d	2,5	2,5	2,5	2,5
5 / 4 N/mm <sup>2</sup>	d/d	2,5	2,5	2,5	2,5
8 / 6 N/mm <sup>2</sup>	d/d	2,5	2,5	2,5	2,5
<p><sup>1)</sup> The compressive strength of the single brick must not be less than 80% of the mean compressive strength.</p> <p>Factor for job site tests see annex C20, table C20.2 and displacements see annex C 21</p>					
fischer injection system FIS V Zero for masonry					<b>Annex C19</b>  Appendix 40 / 42
<b>Performance</b> Autoclaved aerated concrete (cylindrical drill hole), Characteristic resistance under shear loading					

## $\beta$ -factors for job site tests

**Table C20.1:**  $\beta$ -factors for job site tests

Installation and use conditions	d/d		
	24/40	50/80	72/120
temperature range [°C]			
M8	0,81	0,47	0,45
M10	0,62	0,49	0,45
M12 / FIS E 11x85	0,62	0,49	0,52
M16 / FIS E 15x85	0,56	0,45	0,57

**Table C20.2:**  $\beta$ -factors for job site tests for AAC

Installation and use conditions	d/d	
	24/40	50/80
temperature range [°C]		
All sizes	0,58	0,49

fischer injection system FIS V Zero for masonry

**Performances**  
 $\beta$ -factors for job site tests

**Annex C20**

Appendix 41 / 42

**Table C21.1: Displacements**

Material	Size	Effective anchorage depth [mm]	N [kN]	$\delta N_0$ [mm]	$\delta N_\infty$ [mm]	V [kN]	$\delta V_0$ [mm]	$\delta V_\infty$ [mm]
Solid brick acc. to C4-C5	M8	50	0,57	0,00	0,00	0,71	0,08	0,12
		80	1,00	0,00	0,00	1,71	0,32	0,48
	M10	50	0,57	0,00	0,00	0,71	0,18	0,27
		80	1,00	0,01	0,02	1,71	0,50	0,75
	M12	50	1,29	0,03	0,06	0,71	0,05	0,08
		80	1,00	0,01	0,02	1,71	0,75	1,13
	M16	50	1,29	0,03	0,06	0,71	0,35	0,53
		80	1,71	0,04	0,08	1,71	0,20	0,30
Solid calcium silicate (sand-lime) brick acc. to C6-C7	M8	50	0,86	0,03	0,06	1,43	0,32	0,48
		80	0,86	0,00	0,00	1,43		
	M10	50	0,86	0,00	0,00	1,43	0,34	0,51
		80	1,71	0,02	0,04	1,43		
	M12	50	0,86	0,03	0,06	1,43	0,12	0,18
		80	1,71	0,04	0,08	1,43	0,32	0,48
	M16	50	0,86	0,03	0,06	1,43	0,57	0,86
		80	1,14	0,02	0,04	1,43	0,20	0,03
Perforated calcium silicate (sand-lime) brick acc. to C8-C11	M8	12x50	0,71	0,01	0,02	1,00	0,16	0,24
		12x85						
	M8	16x85	0,57	0,02	0,04	1,14	0,57	0,86
	M10	16x130	1,29	0,06	0,12	1,14	1,03	1,55
	M12	20x85	0,57	0,03	0,06	1,86	1,15	1,73
M16	20x130	1,29	0,04	0,08	1,86	1,24	1,86	
Perforated brick Hz acc. to C12-C13	M8	12x50	0,43	0,00	0,00	0,71	0,25	0,38
		12x85	0,71	0,00	0,00	1,43	0,61	0,92
	M8	16x85	0,71	0,03	0,06	1,00	0,36	0,54
	M10	16x130	1,00	0,02	0,04	1,43	0,30	0,45
	M12	20x85	0,71	0,00	0,00	1,00	0,22	0,33
M16	20x130	1,00	0,04	0,08	1,43	0,17	0,26	
Lightweight aggregate concrete hollow block Hbl acc. to C14-C15	M8	16x85	0,14	0,03	0,06	0,57	1,54	2,31
	M10	16x130	0,14	0,02	0,04	0,57	1,01	1,52
	M12	20x85	0,14	0,06	0,12	0,57	1,31	1,97
	M16	20x130	0,21	0,04	0,08	0,57	0,82	1,23
Autoclaved aerated concrete acc. to C16-C19	M8x100 M10x100	0,48	0,08	0,16	0,89	1,49	2,24	
	M12x100	0,49	0,09	0,18	0,89	1,49	2,24	
	M16x100	0,65	0,12	0,24	0,89	1,49	2,24	

fischer injection system FIS V Zero for masonry							<b>Annex C21</b> Appendix 42 / 42	
<b>Performances displacements</b>								