

PRESTANDEDEKLARATION

DoP 0391

för fischer injektionssystem FIS V Plus (Metallankare för användning i betong)

SV

1. Produkttypens unika identifikationskod: **DoP 0391**
2. Avsedd användning/avsedda användningar: **Infästning i efterhand i sprucken och osprucken betong, se bilaga, särskilt bilagor B1 - B14.**
3. Tillverkare: **fischerwerke GmbH & Co. KG, Otto-Hahn-Straße 15, 79211 Denzlingen, Tyskland**
4. Tillverkarens representant: **–**
5. System för bedömning och fortlöpande kontroll av prestanda: **1**
6. Europeiskt bedömningsdokument: **EAD 330499-02-0601**
Europeisk teknisk bedömning: **ETA-20/0603; 2026-01-29**
Tekniskt bedömningsorgan: **DIBt- Deutsches Institut für Bautechnik**
Anmält/anmälda organ: **2873 TU Darmstadt**
7. Angiven prestanda:
Mekanisk hållfasthet och stabilitet (BWR 1)
Karakteristisk bärförmåga för spänning (för statisk och kvasi-statisk belastning):
 - 1) Stålets motståndskraft: se bilaga, särskilt bilagor C1-C4
 - 2) Motstånd mot kombinerat fel vid utdragning och betongkon: se bilaga, särskilt bilagor C5-C11
 - 3) Motstånd i betongkonen: se bilaga, särskilt bilaga C5
 - 4) Kantavstånd för att slippa sprickor under last: se bilaga, särskilt bilaga C5
 - 5) Kraftighet: se bilaga, särskilt bilagor C5 - C11
 - 6) Maximal vridkraft vid installation: se bilaga, särskilt bilagor B3, B4, B5, B7
 - 7) Minsta kant- och axelavstånd: se bilaga, särskilt bilagor B3 - B9**Karakteristisk bärförmåga för skjvning (för statisk och kvasi-statisk belastning):**
 - 8) Motstånd i stålet: se bilaga, särskilt bilagor C1-C4
 - 9) Motstånd mot fläkning: se bilaga, särskilt bilaga C5
 - 10) Motstånd mot skador i betong: se bilaga, särskilt bilaga C5**Förflyttningar under kort- och långvarig belastning:**
 - 11) Förflyttningar under kort- och långvarig belastning: se bilaga, särskilt bilagor C12, C13
 - 12) Motstånd i stålfiberarmerad betong: NPD**Karakteristiskt motstånd och Förskjutningar för seismiska prestandakategorier C1 och C2:**
 - 13) Motstånd mot draglast, förskjutningar, kategori C1: se bilaga, särskilt bilagor C14, C16, C17
 - 14) Motstånd mot draglast, förskjutningar, kategori C2: se bilaga, särskilt bilagor C15, C16, C18
 - 15) Motstånd mot tvärlast, förskjutningar, kategori C1: se bilaga, särskilt bilagor C14, C16, C17
 - 16) Motstånd mot tvärlast, förskjutningar, kategori C2: se bilaga, särskilt bilagor C15, C16, C18**Säkerhet vid brand (BWR 2)**
 - 17) Reaktion vid brand: Klass (A1)**Motståndskraft mot eld:**
 - 18) Brandmotstånd i stålet (tvärlast): NPD
 - 19) Bondbeständighet under brandförhållanden: NPD
 - 20) Brandmotstånd i stålet (tvärlast): NPD**Hygien, hälsa och miljö (BWR 3)**
 - 21) Innehåll, frisläppning och / eller frisläppning av farliga ämnen: NPD
8. Lämplig teknisk dokumentation och/eller särskild teknisk dokumentation: **–**

Prestandan för ovanstående produkt överensstämmer med den angivna prestandan. Denna prestandadeklaration har utfärdats i enlighet med förordning (EU) nr 305/2011 på eget ansvar av den tillverkare som anges ovan.

Undertecknad på tillverkarens vägnar av:



Alexander Zanocco, Verkställande Direktör Försäljning och Verkställande Direktör Forskning & Utveckling



Dieter Pfaff, Chef för Internationella Produktionsfederationen och Kvalitetsledning

Tumlingen, 2026-03-01

Denna DoP har förberetts på olika språk. I händelse av tvist om tolkningen ska den engelska versionen alltid råda.

Bilagan innehåller frivilliga och kompletterande information på engelska som överskrider (det specifika språkets) lagkrav.

Translation guidance Essential Characteristics and Performance Parameters for Annexes

Översättningsråd Grundläggande karaktäristik och prestandaparametrar för Annex

Mechanical resistance and stability (BWR 1)		
Mekanisk hållfasthet och stabilitet (BWR 1)		
Characteristic resistance to tension load (static and quasi-static loading):		
Karakteristisk bärförmåga för spänning (för statisk och kvasi-statisk belastning):		
1	Resistance to steel failure: Stålets motståndskraft:	$N_{Rk,s}$ [kN]
2	Resistance to combined pull-out and concrete cone failure: Motstånd mot kombinerat fel vid utdragning och betongkon:	τ_{Rk} and/or $\tau_{Rk,100}$ [N/mm ²], $\psi_c, \psi_{sus}^0, \psi_{sus,100}$ [-] (BF)
	Resistance to pull-out failure:	$N_{Rk,p}$ and/or $N_{Rk,p,100}$ [kN], ψ_c [-] (BEF)
3	Resistance to concrete cone failure: Motstånd i betongkonen:	$c_{cr,N}$ [mm], $k_{cr,N}$, $k_{ucr,N}$ [-]
4	Edge distance to prevent splitting under load: Kantavstånd för att slippa sprickor under last:	$c_{cr,sp}$ [mm]
5	Robustness: Kraftighet:	γ_{inst} [-]
6	Maximum installation torque: Maximal vridkraft vid installation:	$\max T_{inst}$ [Nm] (BF)
	Installation torque:	T_{inst} [Nm] (BEF)
7	Minimum edge distance, spacing and member thickness: Minsta kant- och axelavstånd:	$c_{min}, s_{min}, h_{min}$ [mm]
Characteristic resistance to shear load (static and quasi-static loading):		
Karakteristisk bärförmåga för skjuvning (för statisk och kvasi-statisk belastning):		
8	Resistance to steel failure: Motstånd i stålet:	$V_{Rk,s}^0$ [kN], $M_{Rk,s}^0$ [Nm], k_7 [-]
9	Resistance to pry-out failure: Motstånd mot fläkning:	k_8 [-]
10	Resistance to concrete edge failure: Motstånd mot skador i betong:	d_{nom}, l_f [mm]
Displacements under short-term and long-term loading:		
Förflyttningar under kort- och långvarig belastning:		
11	Displacements factors under short-term and long-term loading: Förflyttningar under kort- och långvarig belastning:	δ_0, δ_∞ [mm/(N/mm ²)] or [mm/kN]
12	Resistance in steel fibre reinforced concrete: Motstånd i stålfiberarmerad betong:	Description
Characteristic resistance and displacements for seismic performance categories C1 and C2:		
Karakteristiskt motstånd och förskjutningar för seismiska prestandakategorier C1 och C2:		
13	Resistance to tension for seismic performance category C1 Motstånd mot draglast, förskjutningar, kategori C1:	$N_{Rk,s,C1}$ [kN] (all) $\tau_{Rk,C1}$ [N/mm ²] (BF) $N_{Rk,p,C1}$ [kN] (BEF)
14	Resistance to tension and displacements for seismic performance category C2 Motstånd mot draglast, förskjutningar, kategori C2:	$N_{Rk,s,C2}$ [kN] (all) $\tau_{Rk,C2}$ [N/mm ²] (BF) $N_{Rk,p,C2}$ [kN] (BEF) $\delta_{N,C2(50\%)}, \delta_{N,C2(100\%)}$ [mm] (all)
15	Resistance to shear for seismic performance category C1 Motstånd mot tvärlast, förskjutningar, kategori C1:	$V_{Rk,s,C1}$ [kN] (all)
16	Resistance to shear load and displacements for seismic performance category C2 Motstånd mot tvärlast, förskjutningar, kategori C2:	$V_{Rk,s,C2}$ [kN] (all) $\delta_{V,C2(50\%)}, \delta_{V,C2(100\%)}$ [mm] (all)
Safety in case of fire (BWR 2)		
Säkerhet vid brand (BWR 2)		
17	Reaction to fire Reaktion vid brand:	Class Klass (A1)
Resistance to fire		
Motståndskraft mot eld:		
18	Fire resistance to steel failure (tension load): Brandmotstånd i stålet (tvärlast):	$N_{Rk,s,fi}$ [kN]
19	Bond resistance under fire conditions: Bondbeständighet under brandförhållanden:	$k_{fi,p}(\theta)$ [-], $\tau_{Rk,fi}(\theta)$ [N/mm ²] (BF)
20	Fire resistance to steel failure under shear loading: Brandmotstånd i stålet (tvärlast):	$V_{Rk,s,fi}$ [kN], $M_{Rk,s,fi}^0$ [Nm]
Hygiene, health and the environment (BWR 3)		
Hygien, hälsa och miljö (BWR 3)		
21	Content, emission and/or release of dangerous substances: Innehåll, frisläppning och / eller frisläppning av farliga ämnen:	Description/Level

Specific Part

1 Technical description of the product

The "fischer injection system FIS V Plus" is a bonded fastener consisting of a cartridge with injection mortar according to Annex A5 and a steel element according to Annex A1 to A4.

The steel element is placed into a drilled hole filled with injection mortar and is anchored via the bond between metal part, injection mortar and concrete.

The product description is given in Annex A.

2 Specification of the intended use in accordance with the applicable European Assessment Document

The performances given in Section 3 are only valid if the anchor is used in compliance with the specifications and conditions given in Annex B.

The verifications and assessment methods on which this European Technical Assessment is based lead to the assumption of a working life of the anchor of at least 50 and/or 100 years. The indications given on the working life cannot be interpreted as a guarantee given by the producer, but are to be regarded only as a means for choosing the right products in relation to the expected economically reasonable working life of the works.

3 Performance of the product and references to the methods used for its assessment

3.1 Mechanical resistance and stability (BWR 1)

Essential characteristic	Performance
Characteristic resistance to tension load (static and quasi-static loading)	See Annex C1 to C11, B3 to B9
Characteristic resistance to shear load (static and quasi-static loading)	See Annex C1 to C4
Displacements under short-term and long-term loading	See Annex C12 to C13
Characteristic resistance and displacements for seismic performance categories C1 and C2	See Annex C14 to C18

3.2 Safety in case of fire (BWR 2)

Essential characteristic	Performance
Reaction to fire	Class A1
Resistance to fire	No performance assessed

3.3 Hygiene, health and the environment (BWR 3)

Essential characteristic	Performance
Content, emission and/or release of dangerous substances	No performance assessed

4 Assessment and verification of constancy of performance (AVCP) system applied, with reference to its legal base

In accordance with EAD 330499-02-0601 the applicable European legal act is: [96/582/EC].

The system to be applied is: 1

Installation conditions part 1

fischer Anchor rod FIS A / RG (Anchor rod) and commercial standard Threaded rod (Threaded rod)

Pre-positioned installation

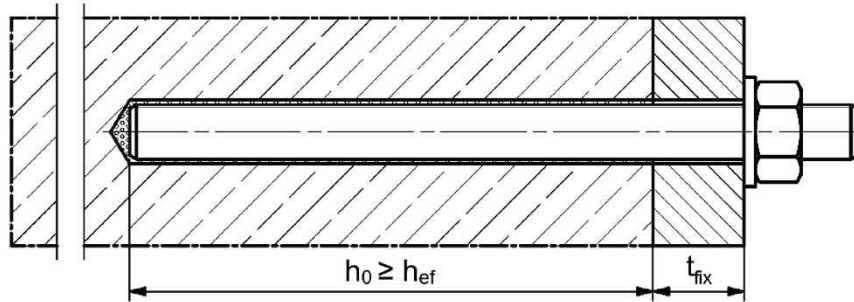

Push through installation (annular gap filled with mortar)

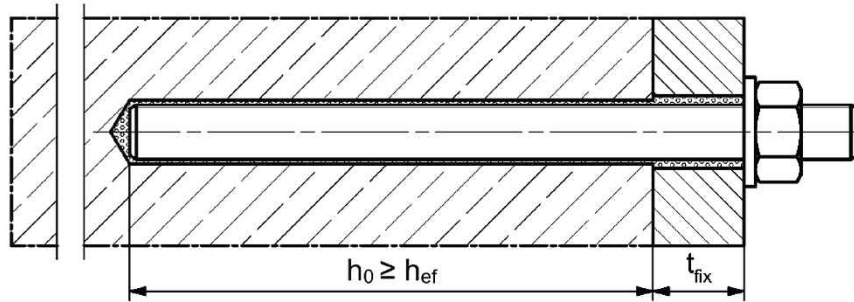

Pre-positioned or push through installation with subsequently injected fischer filling disc (annular gap filled with mortar)

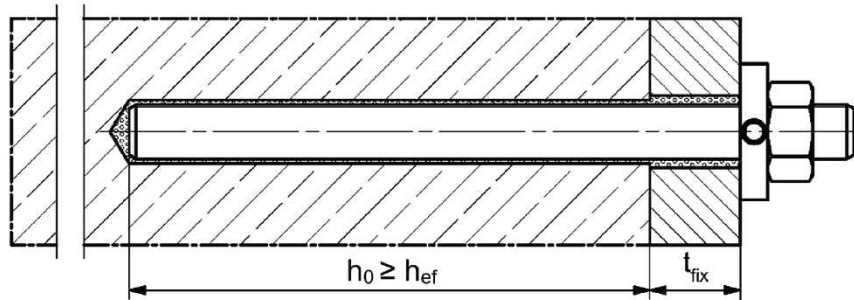

Figures not to scale

h_0 = drill hole depth

h_{ef} = effective embedment depth

t_{fix} = thickness of fixture

fischer injection system FIS V Plus

Product description
Installation conditions part 1

Annex A1

Appendix 3 / 41

Installation conditions part 2

fischer internal threaded anchor RG M I (fischer RG M I)

Pre-positioned installation

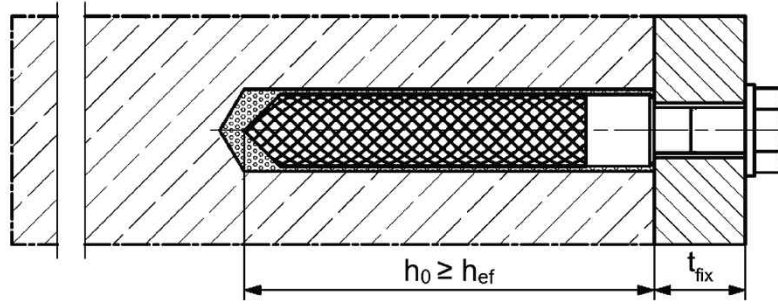

Pre-positioned installation with subsequently injected fischer filling disc (annular gap filled with mortar)

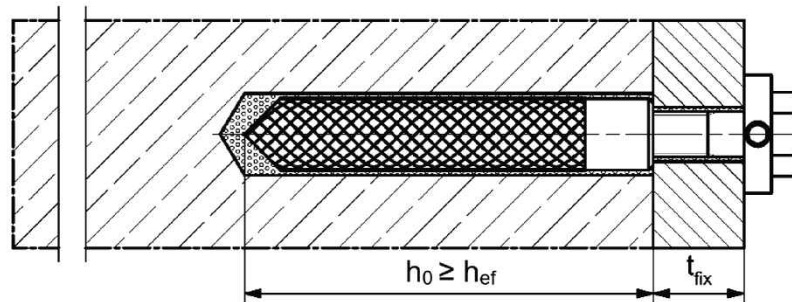

Figures not to scale

h_0 = drill hole depth

h_{ef} = effective embedment depth

t_{fix} = thickness of fixture

fischer injection system FIS V Plus

Product description
Installation conditions part 2

Annex A2

Appendix 4 / 41

Installation conditions part 3

fischer internal threaded anchor FIS IG (fischer FIS IG)

Pre-positioned installation

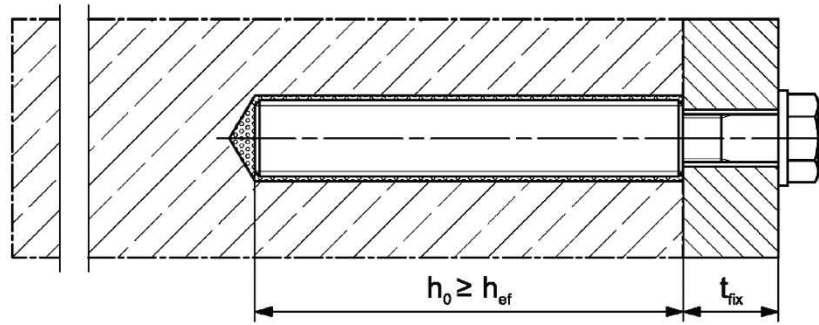

Pre-positioned installation with subsequently injected fischer filling disc (annular gap filled with mortar)

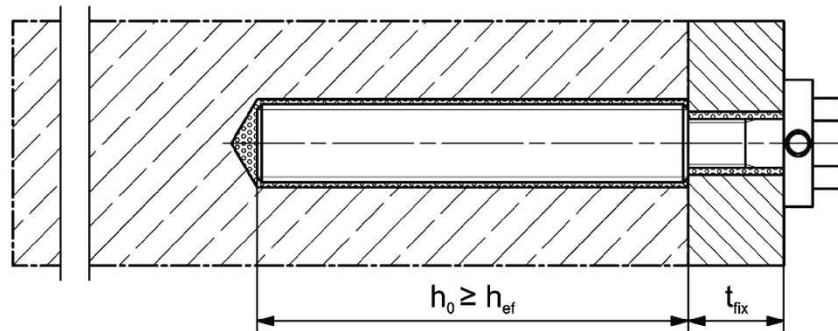

Figures not to scale

h_0 = drill hole depth

h_{ef} = effective embedment depth

t_{fix} = thickness of fixture

fischer injection system FIS V Plus

Product description
Installation conditions part 3

Annex A3

Appendix 5 / 41

Installation conditions part 4

Reinforcing bar

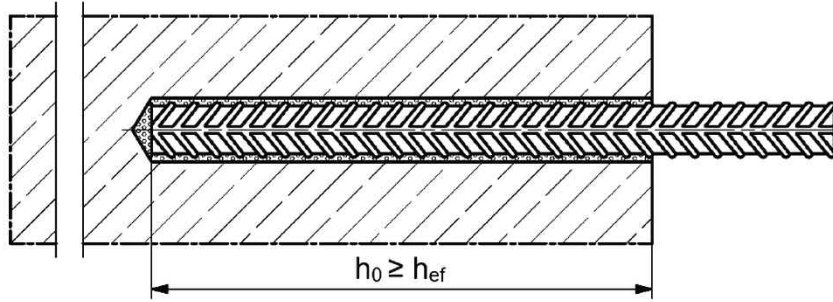

fischer rebar Anchor FRA (fischer FRA)

Pre-positioned installation

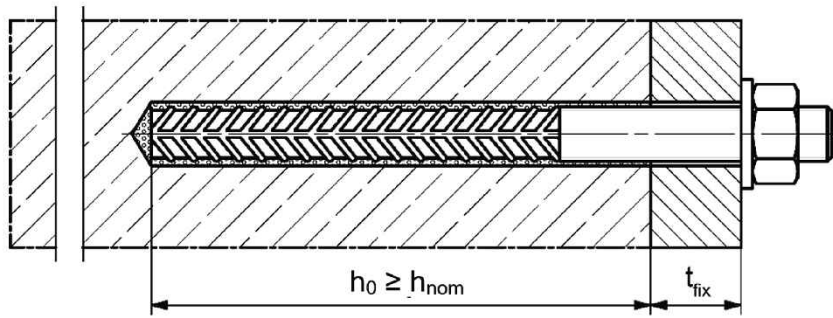

Push through installation (annular gap filled with mortar)

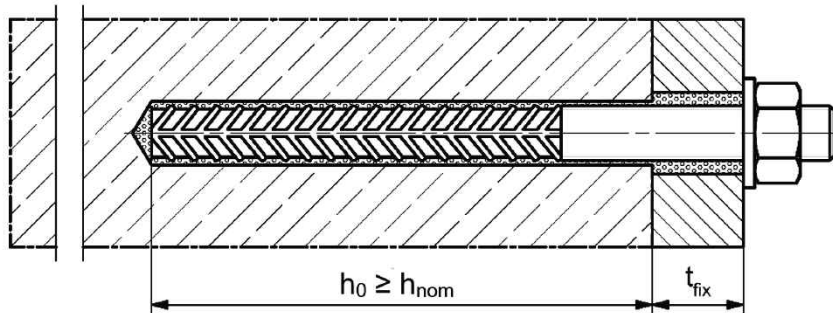

Figures not to scale

h_0 = drill hole depth

h_{ef} = effective embedment depth

t_{fix} = thickness of fixture

h_{nom} = overall fastener embedment depth in the concrete

fischer injection system FIS V Plus

Product description
Installation conditions part 4

Annex A4

Appendix 6 / 41

Overview system components part 1

Injection cartridge (shuttle cartridge) with sealing cap; Sizes: 360 ml, 825 ml

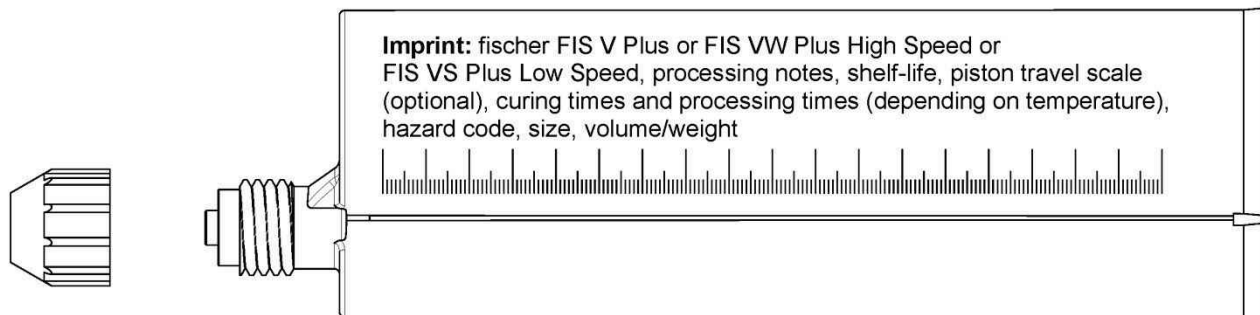

Injection cartridge (coaxial cartridge) with sealing cap; Sizes: 100 ml, 150 ml, 300 ml, 380 ml, 400 ml, 410 ml

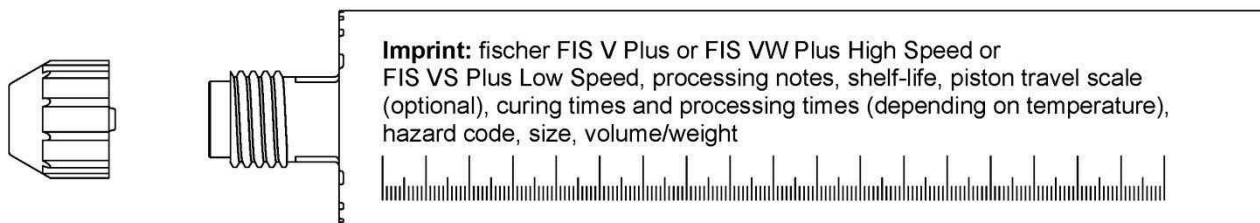

Static mixer FIS MR Plus for injection cartridges up to 825 ml

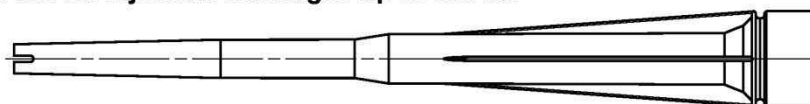

Static mixer FIS JMR for injection cartridges of 825 ml

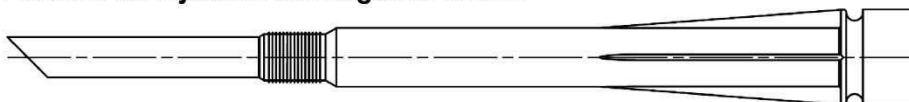

Injection adapter and extension tube Ø 9 for static mixer FIS MR Plus; Injection adapter and extension tube Ø 9 or Ø 15 for static mixer FIS JMR

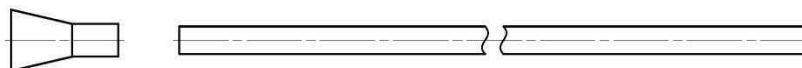

Cleaning brush BS



Blow-out pump AB G



Compressed-air cleaning tool ABP



Figures not to scale

fischer injection system FIS V Plus

Product description

Overview system components part 1;
cartridges / static mixer / cleaning tools / injection adapter

Annex A5

Appendix 7 / 41

Overview system components part 2

Anchor rod / Threaded rod

Size: M6, M8, M10, M12, M16, M20, M24, M27, M30

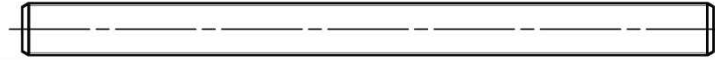

fischer RG M I

Size: M8, M10, M12, M16, M20

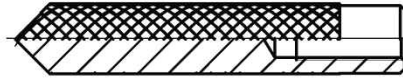

fischer FIS IG

Size: M5, M6, M8, M10, M12, M16, M20

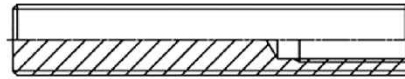

Screw / Anchor rod / Threaded rod / washer / hexagon nut

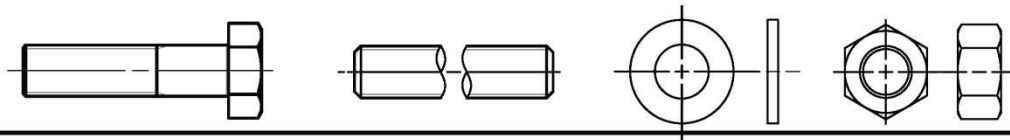

fischer filling disc with injection adapter

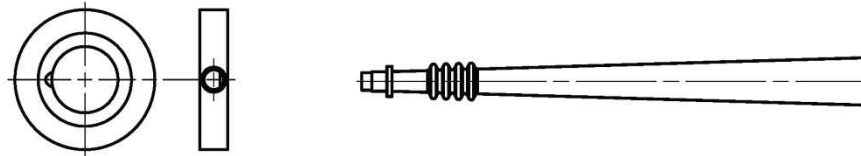

fischer centering clip DD-S / DD-E

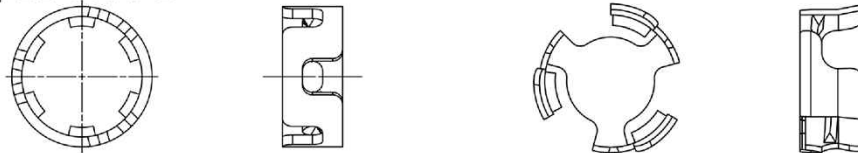

Reinforcing bar

Nominal diameter: $\phi 8$, $\phi 10$, $\phi 12$, $\phi 14$, $\phi 16$, $\phi 20$, $\phi 25$, $\phi 28$



fischer FRA, FRA HCR

Size: M12, M16, M20, M24



Figures not to scale

fischer injection system FIS V Plus

Product description

Overview system components part 2; metal parts, fischer centering clip, injection adapter

Annex A6

Appendix 8 / 41

Table A7.1: Materials

Part	Designation	Material		
1	Injection cartridge	Mortar, hardener, filler		
	Steel grade	Steel zinc plated (zp, hdg)	Stainless steel R acc. to EN 10088-1:2023 Corrosion resistance class CRC III acc. to EN 1993-1-4:2006+A1:2015	High corrosion resistant steel HCR acc. to EN 10088-1:2023 Corrosion resistance class CRC V acc. to EN 1993-1-4:2006+A1:2015
2	Anchor rod / Threaded rod	Property class 4.8, 5.8 or 8.8; EN ISO 898-1:2013 zp ≥ 5 µm, EN ISO 4042:2022 or hot dip galvanised ≥ 40 µm EN ISO 10684:2004+AC:2009 f _{uk} ≤ 1000 N/mm ² A ₅ > 12 % fracture elongation ¹⁾	Property class 50, 70 or 80; EN ISO 3506-1:2020 1.4401; 1.4404; 1.4578; 1.4571; 1.4439; 1.4362; 1.4062; 1.4662; 1.4462; EN 10088-1:2023 f _{uk} ≤ 1000 N/mm ² A ₅ > 12 % fracture elongation ¹⁾	Property class 50, 70 or 80; EN ISO 3506-1:2020 or property class HCR 70 with f _{yk} ≥ 560 N/mm ² ; 1.4565; 1.4529; EN 10088-1:2023 f _{uk} ≤ 1000 N/mm ² A ₅ > 12 % fracture elongation ¹⁾
3	Washer ISO 7089:2000	zinc plated ≥ 5 µm, EN ISO 4042:2022 or hot dip galvanised ≥ 40 µm EN ISO 10684:2004+AC:2009	1.4401; 1.4404; 1.4578; 1.4571; 1.4439; 1.4362; EN 10088-1:2023	1.4565; 1.4529; EN 10088-1:2023
4	Hexagon nut	Property class 5 or 8 acc. EN ISO 898-2:2022 zinc plated ≥ 5 µm, EN ISO 4042:2022 or hot dip galvanised ≥ 40 µm EN ISO 10684:2004+AC:2009	Property class 50, 70 or 80 acc. EN ISO 3506-2:2020 1.4401; 1.4404; 1.4578; 1.4571; 1.4439; 1.4362; EN 10088-1:2023	Property class 50, 70 or 80 acc. EN ISO 3506-2:2020 1.4565; 1.4529; EN 10088-1:2023
5	fischer RG M I / FIS IG	Property class 5.8 EN ISO 898-1:2013 zinc plated ≥ 5 µm, EN ISO 4042:2022	Property class 70 EN ISO 3506-1:2020; 1.4401; 1.4404; 1.4578; 1.4571; 1.4439; 1.4362; EN 10088-1:2023	Property class 70 EN ISO 3506-1:2020 1.4565; 1.4529; EN 10088-1:2023
6	Commercial standard screw or Anchor rod / Threaded rod for fischer RG M I /FIS IG	Property class 5.8 or 8.8; EN ISO 898-1:2013 zinc plated ≥ 5 µm, EN ISO 4042:2022 A ₅ > 8 % fracture elongation	Property class 70 EN ISO 3506-1:2020 1.4401; 1.4404; 1.4578; 1.4571; 1.4439; 1.4362; EN 10088-1:2023 A ₅ > 8 % fracture elongation	Property class 70 EN ISO 3506-1:2020 1.4565; 1.4529; EN 10088-1:2023 A ₅ > 8 % fracture elongation
7	fischer filling disc similar to DIN 6319-G	zinc plated ≥ 5 µm, EN ISO 4042:2022 or hot dip galvanised ≥ 40 µm EN ISO 10684:2004+AC:2009	1.4401; 1.4404; 1.4578; 1.4571; 1.4439; 1.4362; EN 10088-1:2023	1.4565; 1.4529; EN 10088-1:2023
8	Rebar	EN 1992-1-1:2004 and AC:2010, Annex C Bars and de-coiled rods, class B or C with f _{yk} and k according to NDP or NCI according to EN 1992-1-1/NA; f _{uk} = f _{ik} = k · f _{yk} (A ₅ > 8 %) ¹⁾		
9	fischer FRA	Rebar part: Bars and de-coiled rods class B or C with f _{yk} and k according to NDP or NCI of EN 1992-1-1:2004+AC:2010 f _{uk} = f _{ik} = k · f _{yk} (A ₅ > 8 %) Threaded part: Property class 80 EN ISO 3506-1:2020	1.4401, 1.4404, 1.4571, 1.4578, 1.4439, 1.4362, 1.4062 acc. to EN 10088-1:2023 Corrosion resistance class CRC III acc. to EN 1993-1-4:2006+A1:2015 1.4565; 1.4529 acc. to EN 10088-1:2023 Corrosion resistance class CRC V acc. to EN 1993-1-4:2006+A1:2015 f _{uk} ≤ 1000 N/mm ² ; fracture elongation A ₅ > 8 %	

¹⁾ Fracture elongation A₅ > 8 %, for applications without requirements for seismic performance category C1 or C2

fischer injection system FIS V Plus



Product description
Materials

Annex A7

Appendix 9 / 41

Specifications of intended use part 1

Table B1.1: Overview use and performance categories

		FIS V Plus with ...										
		Anchor rod Threaded rod	fischer RG M I	fischer FIS IG	Reinforcing bar	fischer FRA						
Hammer drilling with standard drill bit			all sizes									
Hammer drilling with hollow drill bit (fischer „FHD“, Heller „Duster Expert“; Bosch „Speed Clean“; Hilti „TE-CD, TE-YD“, DreBo „D-Plus“, DreBo „D-Max“)			Nominal drill bit diameter (d ₀) 12 mm to 35 mm									
Static and quasi static load, in	uncracked concrete	all sizes	Tables: C1.1 C5.1 C6.1 C7.1 C8.1 C12.1	all sizes	Tables: C2.1 C5.1 C9.1 C12.2	all sizes	Tables: C3.1 C5.1 C6.1 C9.1 C12.2	all sizes	Tables: C4.1 C5.1 C10.1 C13.1	all sizes	Tables: C4.2 C5.1 C11.1 C13.2	
	cracked concrete	M8 to M30	-2)	-2)	-2)	-2)	φ 10 to φ 28	-2)	-2)	-2)	-2)	
Seismic performance category	C1 ¹⁾	M10 to M30	Tables: C14.1 C15.1 C16.1	All sizes		-2)	-2)	-2)	-2)	-2)	-2)	
	C2 ¹⁾	M12 M16 M20	Tables: C15.1 C17.1 C18.1									
Use category	11 dry or wet concrete	all sizes										
	12 water filled hole	M12 to M30	all sizes	all sizes	-2)	-2)	-2)	-2)	-2)	-2)	-2)	
Resistance to fire in concrete (only hammer drilling with standard / hollow drill bits)		-2)	-2)	-2)	-2)	-2)	-2)	-2)	-2)	-2)	-2)	
Installation direction		D3 (downward and horizontal and upwards (e.g. overhead) installation)										
Installation temperature		T _{i,min} = -10 °C to T _{i,max} = +40 °C										
In-service temperature	Temperature range I	-40 °C to +80 °C		(max. short term temperature +80 °C; max. long term temperature +50 °C)								
	Temperature range II	-40 °C to +120 °C		(max. short term temperature +120 °C; max. long term temperature +72 °C)								

¹⁾ Not for FIS VW Plus High Speed and FIS VS Plus Low Speed

²⁾ No performance assessed

fischer injection system FIS V Plus

Intended use
Specifications part 1

Annex B1

Appendix 10 / 41

Specifications of intended use part 2

Base materials:

- Compacted reinforced or unreinforced normal weight concrete without fibres of strength classes C12/15 to C50/60 according to EN 206:2013+A2:2021.

Use conditions (Environmental conditions):

- Fastener intended for use in structures subject to dry, internal conditions (all materials).
- For all other conditions according to EN 1993-1-4:2006+A1:2015 corresponding to corrosion resistance classes to **Annex A7 Table A7.1**.

Design:

- Fastenings are designed in accordance with:
EN 1992-4:2018.
- The structural design is conducted under responsibility of a designer experienced in the field of anchorages and concrete works.
- Verifiable calculation notes and drawings are to be prepared taking account of the loads to be anchored. The position of the fastener is indicated on the design drawings (e. g. position of the fastener relative to reinforcement or to supports, etc.).

Installation:

- Fastener installation is to be carried out by appropriately qualified personnel and under the supervision of the person responsible for technical matters of the site.
- Fastening depth should be marked and adhered to installation.
- Overhead installation is allowed (necessary equipment see installation instruction).

fischer injection system FIS V Plus

Intended use
Specifications part 2

Annex B2
Appendix 11 / 41

Table B3.1: Installation parameters for Anchor rods / Threaded rods

Anchor rods / Threaded rods		Thread	M6	M8	M10	M12	M16	M20	M24	M27	M30	
Nominal drill hole diameter	d_0	[mm]	8	10	12	14	18	24	28	30	35	
Drill hole depth	$h_0^{3)}$		$h_0 \geq h_{ef}$									
Effective embedment depth	$h_{ef, min}$		40	40 ²⁾	40 ²⁾	48	64	80	96	108	120	
	$h_{ef, max}$		72	160	200	240	320	400	480	540	600	
Simplified spacing and edge distance ¹⁾	$s=c$		40	40	45	55	65	85	105	125	140	
Maximum diameter of the clearance hole of the fixture	pre-positioned installation d_f		7	9	12	14	18	22	26	30	33	
	push through installation d_f		9	12	14	16	20	26	30	33	40	
Minimum thickness of concrete member	h_{min}	$h_{ef} + 30 (\geq 100)$					$h_{ef} + 2d_0$					
Maximum installation torque	$\max T_{inst}$	[Nm]	5	10	20	40	60	120	150	200	300	

- 1) Detailed calculation according to **Annex B8 and B9**.
- 2) $h_{ef, min} \geq 60$ for concrete C12/15 and C16/20
- 3) When using centering clips DD-S / DD-E, observe the deviating specifications as specified in **Table B11.1**.

Anchor rod / Threaded rod



Marking (on random place) fischer Anchor rod:

Steel zinc plated PC ¹⁾ 8.8	• or +	Steel hot-dip PC ¹⁾ 8.8	•
High corrosion resistant steel HCR PC ¹⁾ 50	•	High corrosion resistant steel HCR PC ¹⁾ 70	-
High corrosion resistant steel HCR PC ¹⁾ 80	(Stainless steel R property class 50	~
Stainless steel R property class 80	*		

Alternatively: Colour coding according to DIN 976-1: 2016

¹⁾ PC = property class

Installation conditions:

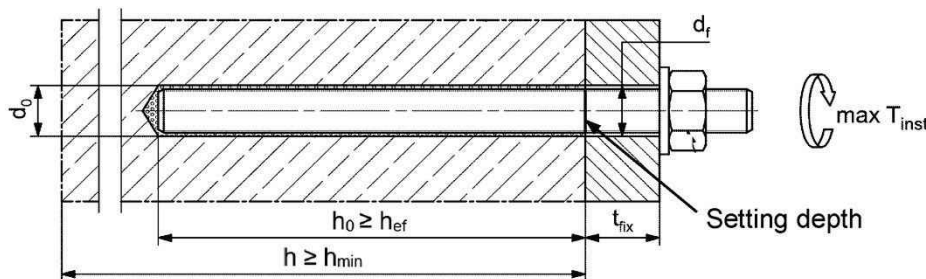

Threaded rods, washers and hexagon nuts may also be used if the following requirements are fulfilled:

- Materials, dimensions and mechanical properties according to **Annex A7, Table A7.1**.
- Inspection certificate 3.1 according to EN 10204:2004, the documents have to be stored.
- Setting depth is marked.
- Steel load-bearing capacities for hot-dip galvanised parts are only valid if the threaded rod and nut are correctly paired. The strength class of the nut must be one strength class higher than that of the threaded rod ($\geq M12$ in combination with tolerance class 6AX in accordance with EN ISO 10684:2004+AC:2009 two strength classes higher). The pairing of undersized threaded rods (additional designation U according to EN ISO 10684) with oversized nuts (additional designation Z or X according to EN ISO 10684) is not permitted under any circumstances.

Figures not to scale

fischer injection system FIS V Plus

Intended use
Installation parameters Anchor rods / Threaded rods

Annex B3

Appendix 12 / 41

Table B4.1: Installation parameters for fischer RG M I

fischer RG M I		Thread	M8	M10	M12	M16	M20
Diameter of Anchor	$d_{nom} = d_H$	[mm]	12	16	18	22	28
Nominal drill hole diameter	d_0		14	18	20	24	32
Drill hole depth	h_0		$h_0 \geq h_{ef} = L_H$				
Effective embedment depth ($h_{ef} = L_H$)	h_{ef}		90	90	125	160	200
Minimum spacing and minimum edge distance	s_{min} = c_{min}		55	65	75	95	125
Maximum diameter of clearance hole in the fixture	d_f		9	12	14	18	22
Minimum thickness of concrete member	h_{min}		120	125	165	205	260
Maximum screw-in depth	$l_{E,max}$		18	23	26	35	45
Minimum screw-in depth	$l_{E,min}$		8	10	12	16	20
Maximum installation torque	$\max T_{inst}$	[Nm]	10	20	40	80	120

fischer RG M I

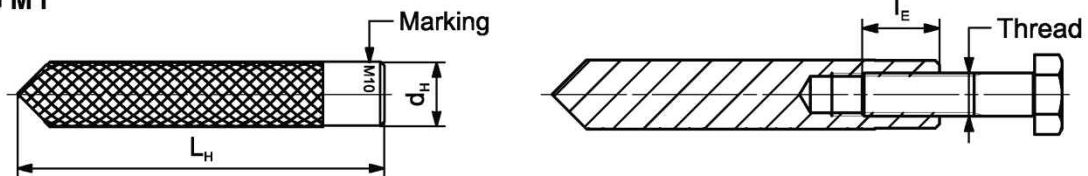

Marking: Anchor size e. g.: **M10**
 Stainless steel → additional **R**; e.g.: **M10 R**
 High corrosion resistant steel → additional **HCR**; e.g.: **M10 HCR**

Retaining bolt or Anchor rod / Threaded rods (including nut and washer) must comply with the appropriate material and strength class of **Annex A7, Table A7.1**.

Installation conditions:

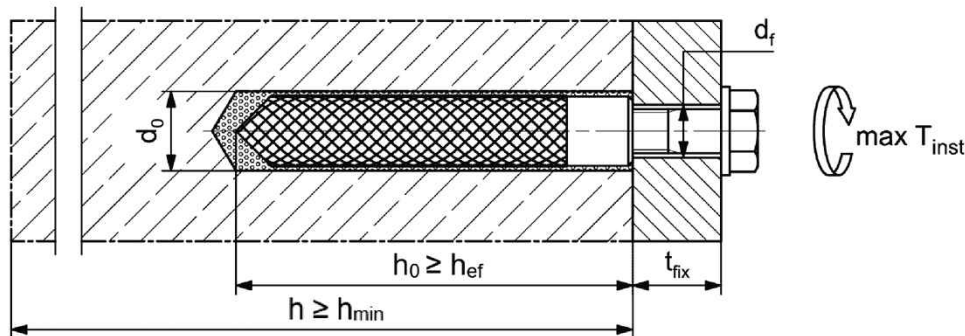

Figures not to scale

fischer injection system FIS V Plus

Intended use
 Installation parameters fischer RG M I

Annex B4
 Appendix 13 / 41

Table B5.1: Installation parameters for fischer FIS IG

fischer FIS IG		Thread	M5	M6	M8	M10	M12	M16	M20
Diameter of anchor	$d_{nom} = d_H$	[mm]	10	10	12	16	20	24	30
Nominal drill hole diameter	d_0		12	12	14	18	24	28	35
Drill hole depth	h_0 ¹⁾		$h_0 \geq h_{ef} = L_H$						
Effective embedment depth ($h_{ef} = L_H$)	$h_{ef, min}$		40 ²⁾	40 ²⁾	48	64	80	96	120
	$h_{ef, max}$		200	200	240	320	400	480	600
Minimum spacing	s_{min}		according to Annex B8						
Minimum edge distance	c_{min}		according to Annex B8						
Diameter of clearance hole in the fixture	d_f		6	7	9	12	14	18	22
Minimum thickness of concrete member	h_{min} ¹⁾		$h_{ef} + 30 (\geq 100)$			$h_{ef} + 2d_0$			
			18	18	20	25	30	40	50
Maximum screw-in depth	$l_{E, max}$	8	8	10	12	14	19	23	
Minimum screw-in depth	$l_{E, min}$								
Maximum installation torque	$\max T_{inst}$	[Nm]	5	5	10	20	40	80	120

- 1) When using centering clips DD-S / DD-E, observe the deviating specifications as specified in **Table B11.1**.
- 2) $h_{ef, min} \geq 60$ for concrete C12/15 and C16/20.

fischer FIS IG

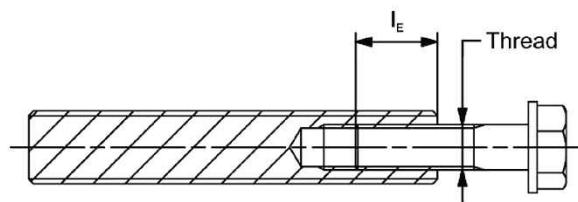
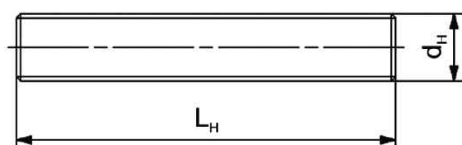

Marking (at any location) Anchor rod:

High corrosion resistant steel HCR property class 70

Bolts or threaded rods (including nut and washer) must comply with the relevant material and strength class as specified in **Annex A7, Table A7.1**.

Installation conditions:

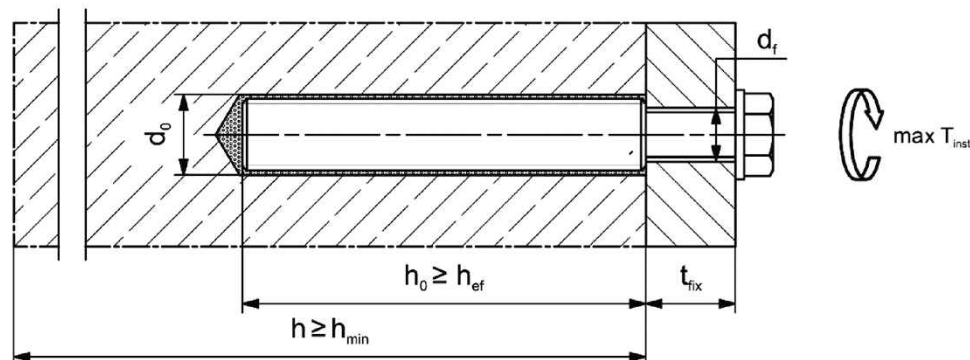

Figures not to scale

fischer injection system FIS V Plus

Intended use
Installation parameters fischer FIS IG

Annex B5
Appendix 14 / 41

Table B6.1: Installation parameters for reinforcing bars

Nominal diameter of the bar		ϕ	8 ²⁾	10 ²⁾	12 ²⁾	14	16	20	25	28			
Nominal drill hole diameter	d_0	[mm]	10	12	12	14	14	16	18	20	25	30	35
Drill hole depth	h_0		$h_0 \geq h_{ef}$										
Effective embedment depth	$h_{ef,min}$		60	60	70	75	80	90	100	112			
	$h_{ef,max}$		160	200	240	280	320	400	500	560			
Simplified spacing and edge distance ¹⁾	$s = c$		40	45	55	60	65	85	110	130			
Minimum thickness of concrete member	h_{min}	$h_{ef} + 30$ (≥ 100)				$h_{ef} + 2d_0$							

¹⁾ Detailed calculation according to **Annex B8** and **B9**.

²⁾ Both drill hole diameters can be used.

Reinforcing bar



- The minimum value of related rib area $f_{R,min}$ must fulfil the requirements of EN 1992-1-1:2011.
- The rib height must be within the range: $0,05 \cdot \phi \leq h_{rib} \leq 0,07 \cdot \phi$
(ϕ = Nominal diameter of the bar, h_{rib} = rib height).

Installation conditions:

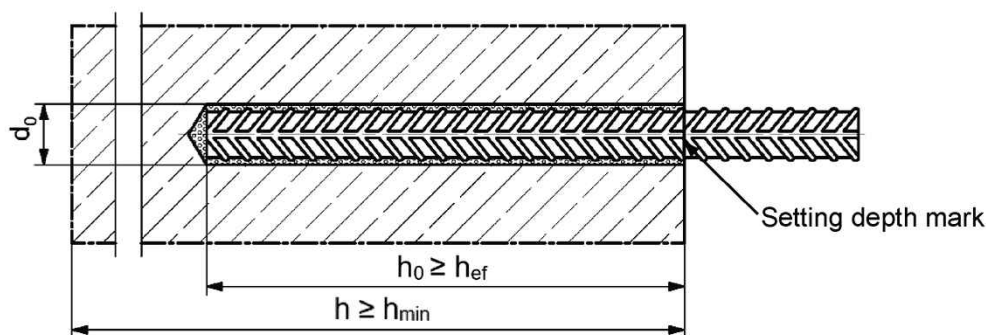

Figures not to scale

fischer injection system FIS V Plus

Intended use
Installation parameters reinforcing bars

Annex B6

Appendix 15 / 41

Table B7.1: Installation parameters for fischer FRA

fischer FRA		Thread	M12 ²⁾	M16	M20	M24	
Nominal diameter of the bar	ϕ	[mm]	12		16	20	25
Nominal drill hole diameter	d_0		14	16	20	25	30
Drill hole depth	h_0		$h_{ef} + l_e = h_{nom}$				
Effective embedment depth	$h_{ef,min}$		70	80	90	96	
	$h_{ef,max}$		140	220	300	380	
Distance concrete surface to welded joint	l_e		100				
Simplified spacing and edge distance ¹⁾	s		55	65	85	105	
	c						
Maximum Diameter of clearance hole in the fixture	pre-positioned anchorage d_f		14	18	22	26	
	push through anchorage d_f		18	22	26	32	
Minimum thickness of concrete member	h_{min}	$h_0 + 30$ (≥ 100)	$h_0 + 2d_0$				
Maximum installation torque	$\max T_{inst}$	[Nm]	40	60	120	150	



1) Detailed calculation according to **Annex B8** and **B9**.

2) Both drill hole diameters can be used.

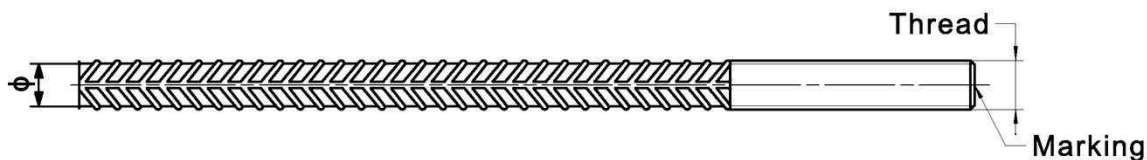
fischer FRA



Marking frontal e.g:

-  FRA (for stainless steel);
-  FRA HCR (for high corrosion resistant steel HCR)

Installation conditions:

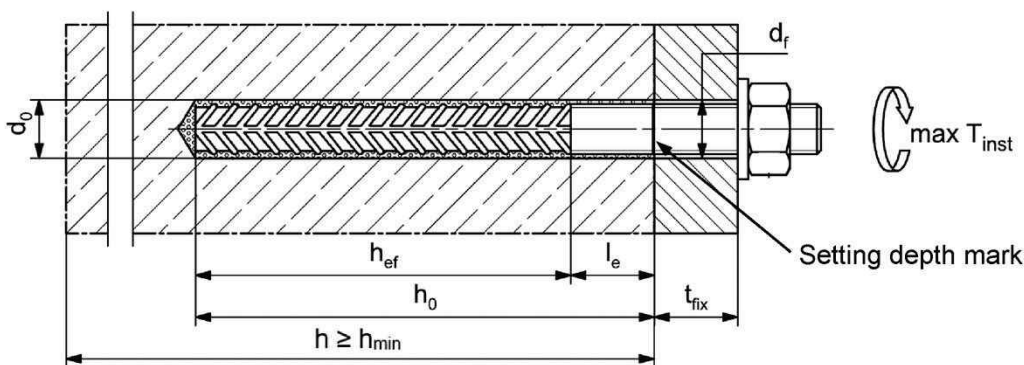

Figures not to scale

fischer injection system FIS V Plus

Intended use
Installation parameters fischer FRA

Annex B7

Appendix 16 / 41

Table B8.1: Minimum spacing and minimum edge distance for Anchor rods / Threaded rods, reinforcing bars, fischer FIS IG and fischer FRA

Anchor rods / Threaded rods		M6	M8	M10	-	-	-	M12	-	-	M16	-	
fischer FIS IG		-	-	-	M5	M6	M8	-	M10	-	-	M12	
Reinforcing bars / fischer FRA (nominal diameter)		ϕ	8	10	-	-	-	12	-	14	16	-	
Minimum edge distance													
Uncracked / cracked concrete	c_{min}	[mm]	40	40	45	40	45	45	45	50	45	50	55
Minimum spacing	s		according to Annex B9										
Minimum spacing													
Uncracked / cracked concrete	s_{min}	[mm]	40	40	45	40	45	55	55	65	60	65	85
Minimum edge distance	c		according to Annex B9										
Required projecting area													
Uncracked concrete C12/15 and	$A_{sp,req}$	[1000 mm ²]	-	11,3	18,3	5,0	5,0	7,8	31,0	11,3	-	33,8	18,4
Cracked concrete C16/20			-	9,2	14,1	3,6	3,6	6,4	23,2	9,2	-	26,1	14,1
Uncracked concrete \geq C20/25			8,0	8,0	13,0	3,5	3,5	5,5	22,0	8,0	23,0	24,0	13,0
Cracked concrete			6,5	6,5	10,0	2,5	2,5	4,5	16,5	6,5	17,5	18,5	10,0
Anchor rods / Threaded rods													
		M20	-	M24	-	M27	-					M30	
fischer IG		-	M16	-	-	-	-			M20		-	
Reinforcing bars / fischer FRA (nominal diameter)		ϕ	20	-	-	25	-	28				-	
Minimum edge distance													
Uncracked / cracked concrete	c_{min}	[mm]	55	60	60	75	75	80	80	80	80	80	
Minimum spacing	s		according to Annex B9										
Minimum spacing													
Uncracked / cracked concrete	s_{min}	[mm]	85	105	105	120	120	140	140	140	140	140	
Minimum edge distance	c		according to Annex B9										
Required projecting area													
Uncracked concrete C12/15 and	$A_{sp,req}$	[1000 mm ²]	54,2	30,3	56,3	-	66,9	-	36,7	90,1			
Cracked concrete C16/20			51,5	23,3	42,9	-	51,4	-	28,2	69,0			
Uncracked concrete \geq C20/25			38,5	21,5	40,0	47,5	47,5	64,0	26,0	64,0			
Cracked concrete			29,5	16,5	30,5	36,5	36,5	49,0	20,0	49,0			

Splitting failure for minimum edge distance and spacing in dependence of the effective embedment depth h_{ef} .

For the calculation of minimum spacing and minimum edge distance of anchors in combination with different embedment depths and thicknesses of concrete members the following equation shall be fulfilled:

$$A_{sp,req} < A_{sp,t}$$

$A_{sp,req}$ = required projecting area

$A_{sp,t}$ = projecting area (according to **Annex B9**)

fischer injection system FIS V Plus

Intended use

Minimum spacing and edge distance for Anchor rods / Threaded rods, fischer FIS IG, reinforcing bars and fischer FRA

Annex B8

Appendix 17 / 41

Table B9.1: Projecting area $A_{sp,t}$ with concrete member thickness $h > h_{ef} + 1,5 \cdot c$ and $h \geq h_{min}$

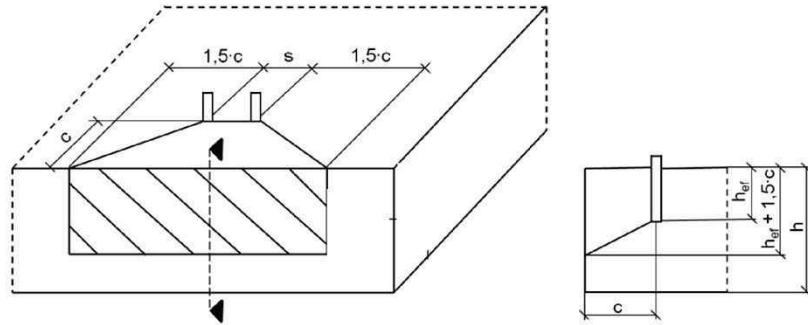

Single fastener	$A_{sp,t} = (3 \cdot c) \cdot (h_{ef} + 1,5 \cdot c)$	[mm ²]	with $c \geq c_{min}$
Group of fastener with $s > 3 \cdot c$	$A_{sp,t} = (6 \cdot c) \cdot (h_{ef} + 1,5 \cdot c)$	[mm ²]	
Group of fastener with $s \leq 3 \cdot c$	$A_{sp,t} = (3 \cdot c + s) \cdot (h_{ef} + 1,5 \cdot c)$	[mm ²]	with $c \geq c_{min}$ and $s \geq s_{min}$

Table B9.2: Projecting area $A_{sp,t}$ with concrete member thickness $h \leq h_{ef} + 1,5 \cdot c$ and $h \geq h_{min}$

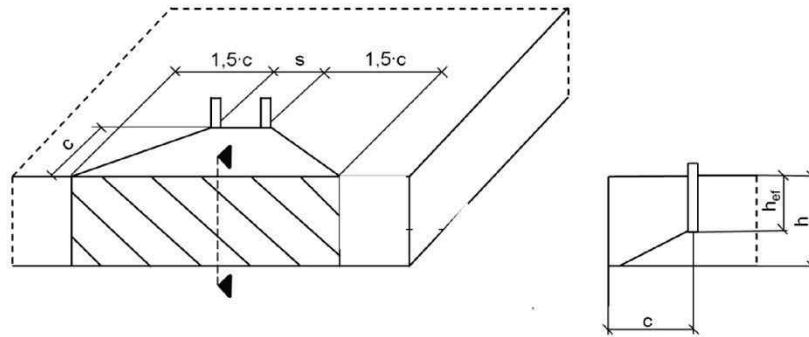

Single fastener	$A_{sp,t} = 3 \cdot c \cdot \text{existing } h$	[mm ²]	with $c \geq c_{min}$
Group of fastener with $s > 3 \cdot c$	$A_{sp,t} = 6 \cdot c \cdot \text{existing } h$	[mm ²]	
Group of fastener with $s \leq 3 \cdot c$	$A_{sp,t} = (3 \cdot c + s) \cdot \text{existing } h$	[mm ²]	with $c \geq c_{min}$ and $s \geq s_{min}$

Edge distance and axial spacing shall be rounded up to at least 5 mm.

Figures not to scale

fischer injection system FIS V Plus

Intended use

Minimum thickness of concrete member for Anchor rods / Threaded rods, fischer FIS IG, fischer FRA and reinforcing bars, minimum spacing and edge distance

Annex B9

Appendix 18 / 41

Table B10.1: Parameters of the cleaning brush BS (steel brush with steel bristles)

The size of the cleaning brush refers to the drill hole diameter.

Nominal drill hole diameter	d_0	[mm]	8	10	12	14	16	18	20	24	25	28	30	32	35
Steel brush diameter BS	d_b		9	11	14	16	20		25	26	27	30	40		

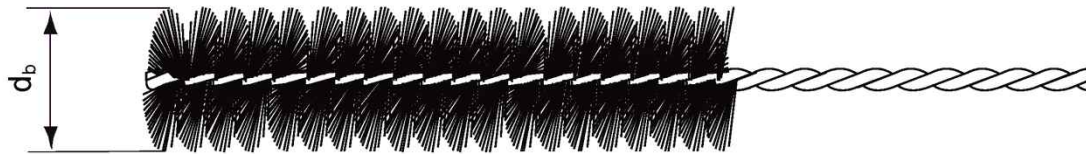
**Table B10.2: Maximum processing time of the mortar and minimum curing time**
(During the curing time of the mortar the concrete temperature may not fall below the listed minimum temperature)

Temperature at anchoring base [°C]	Maximum processing time t_{work}			Minimum curing time t_{cure} ¹⁾		
	FIS VW Plus High Speed	FIS V Plus	FIS VS Plus Low Speed	FIS VW Plus High Speed	FIS V Plus	FIS VS Plus Low Speed
-10 to -5 ²⁾	5 min	-	-	12 h	-	-
> -5 to 0 ²⁾	5 min	13 min	-	3 h	24 h	-
> 0 to 5 ²⁾	5 min	13 min	20 min	3 h	3 h	6 h
> 5 to 10	3 min	9 min	20 min	50 min	90 min	3 h
> 10 to 20	1 min	5 min	10 min	30 min	60 min	2 h
> 20 to 30	-	4 min	6 min	-	45 min	60 min
> 30 to 40	-	2 min	4 min	-	35 min	30 min

¹⁾ In wet concrete or water filled holes the curing times must be doubled.

²⁾ Minimal cartridge temperature +5°C.

Table B10.3: Conditions for use static mixer without an extension tube

Nominal drill hole diameter	d_0	[mm]	8	10	12	14	16	18	20	24	25	28	30	32	35
Drill hole depth h_0 by using	FIS MR Plus		≤90			≤120	≤140	≤150	≤160	≤190	≤210				
	FIS JMR	-	-	-	≤90	≤160	≤180	≤190	≤220		≤250				

fischer injection system FIS V Plus

Intended use
Cleaning brush (steel brush)
Processing time and curing time

Annex B10

Appendix 19 / 41

Table B11.1: Parameters of the fischer centering clip DD-S / DD-E

Anchor rods / Threaded rods			M12	M16	M20	M24	M27	M30
fischer FIS IG			M8	M10	M12	M16	-	M20
fischer centering clip DD-S / DD-E			M12	M16	M20	M24	M27	M30
fischer centering clip DD-S	h_{DD-S}	[mm]	6,5	8,0	9,0	10,0	10,0	10,0
fischer centering clip DD-E	h_{DD-E}	[mm]	12,0	13,5	18,0	19,0	19,0	19,0
Drill hole depth	h_0	[mm]	$h_0 \geq h_{nom} + 3 \text{ mm}$					
Minimum thickness of concrete member	h_{min}	[mm]	$h_{nom} + 30$ (≥ 100)	$h_{nom} + 2d_0$				

The uppermost DD-S clip should be positioned approx. 5 - 10 mm below the concrete surface.
 The effective embedment depth h_{ef} is calculated as follows when using the DD-S / DD-E clips.

$$h_{ef} = h_{nom} - h_{DD-E} - n \cdot h_{DD-S} \quad n = \text{number of DD-S clips used}$$

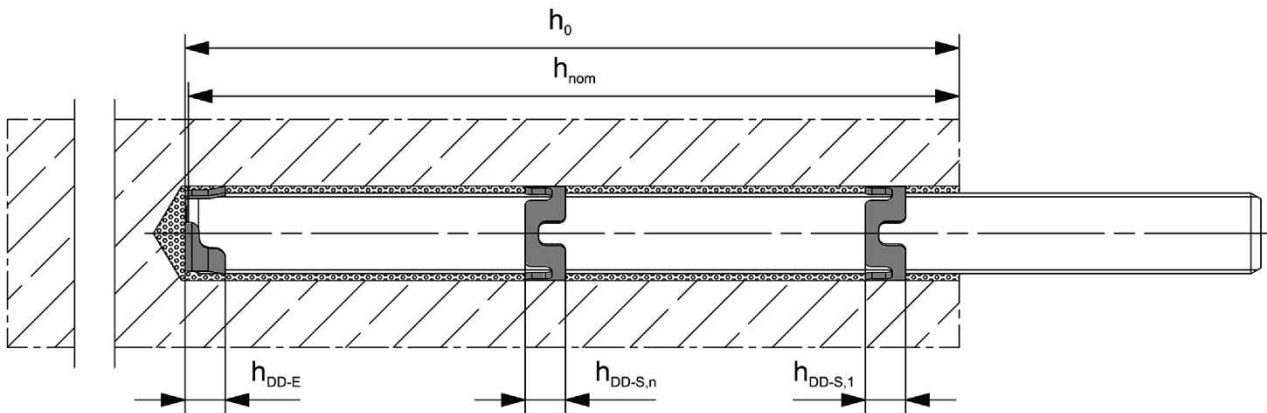

Figures not to scale

fischer injection system FIS V Plus

Intended use
 fischer centering clip DD-S / DD-E

Annex B11

Appendix 20 / 41

Installation instructions part 1

Drilling and cleaning the hole (hammer drilling with standard drill bit)

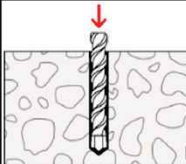
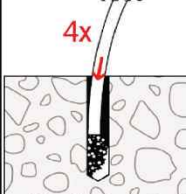
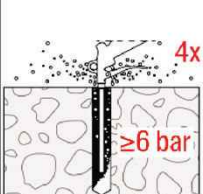
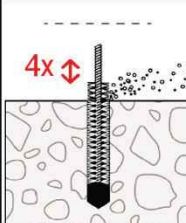
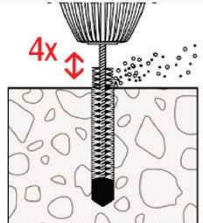
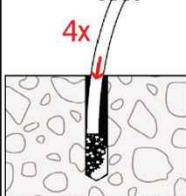
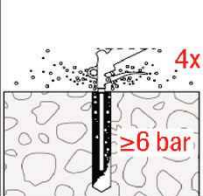
1		<p>Drill the hole. Nominal drill hole diameter d_0 and drill hole depth h_0 see Tables B3.1, B4.1, B5.1, B6.1 or B7.1.</p>
2		 <p>Clean the drill hole: For $h_{ef} \leq 12d$ and $d_0 < 18$ mm blow out the hole four times by hand.</p> <p>For $h_{ef} > 12d$ and / or $d_0 \geq 18$ mm blow out the hole four times with oil-free compressed air ($p \geq 6$ bar). Use suitable compressed-air nozzle</p>
3		 <p>Brush the drill hole four times. For $d_0 < 30$ mm brush process can be performed by hand. For deep holes use an extension. Use suitable brushes (see Table B10.1).</p> <p>Brush the drill hole four times. For drill hole diameter ≥ 30 mm use a power drill. For deep holes use an extension. Use suitable brushes (see Table B10.1).</p>
4		 <p>Clean the drill hole: For $h_{ef} \leq 12d$ and $d_0 < 18$ mm blow out the hole four times by hand.</p> <p>For $h_{ef} > 12d$ and / or $d_0 \geq 18$ mm blow out the hole four times with oil-free compressed air ($p \geq 6$ bar). Use suitable compressed-air nozzle.</p>

Go to step 5

Drilling and cleaning the hole (hammer drilling with hollow drill bit)

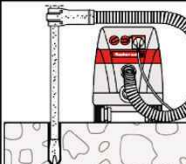
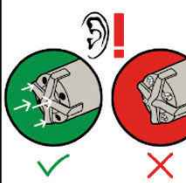
1		<p>Check a suitable hollow drill (see Table B1.1) for correct operation of the dust extraction.</p>
2		<p>Use a suitable dust extraction system, e.g. fischer FVC 35 M or a comparable dust extraction system with equivalent performance data Drill the hole with hollow drill bit. The dust extraction system has to extract the drill dust nonstop during the drilling process and must be adjusted to maximum power. Nominal drill hole diameter d_0 and drill hole depth h_0 see Tables B3.1, B4.1, B5.1, B6.1, B7.1.</p>

Go to step 5

fischer injection system FIS V Plus

Intended use
Installation instructions part 1

Annex B12

Appendix 21 / 41

Installation instructions part 2

Preparing the cartridge

5

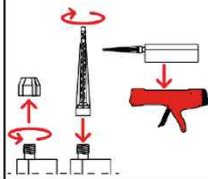

Remove the sealing cap
Screw on the static mixer
Place the cartridge into the dispenser

6

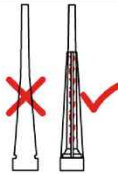

Ensuring that the spiral inside the mixer is clearly visible.

7



Extrude approximately 10 cm of material out until the resin is evenly grey in colour.
Do not use mortar that is not uniformly grey.

Go to step 8

Injection of the mortar

8

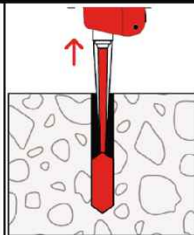

For $h_0 = h_{ef}$ fill approximately 2/3 of the drill hole with mortar. For $h_0 > h_{ef}$ more mortar is needed. Always begin from the bottom of the hole and avoid bubbles.

9

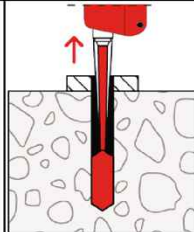

Push-through installation:

the drill hole in the fixture must be also filled with mortar.

10

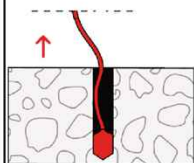

The conditions for mortar injection without extension tube can be found in **Table B10.3.**

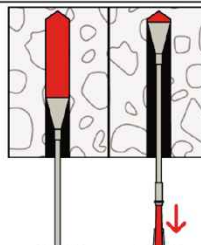

For overhead installation, deep holes ($h_0 > 250$ mm) or drill hole diameter ($d_0 \geq 30$ mm) use an injection-adapter.

Go to step 11

fischer injection system FIS V Plus

Intended use
Installation instructions part 2

Annex B13

Appendix 22 / 41

Installation instructions part 3

Installation of Anchor rods / Threaded rods, fischer RG M I and fischer FIS IG

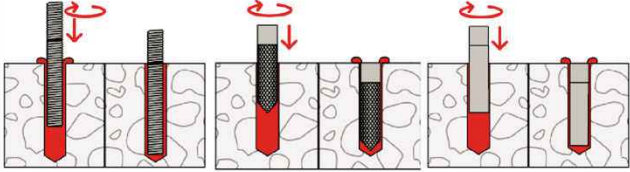
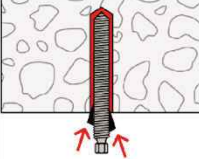
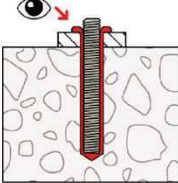
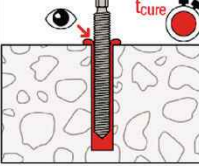
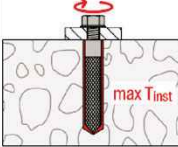
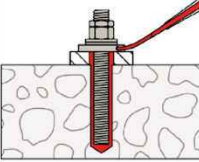
11		<p>Only use clean and oil-free metal parts. Push the Anchor rod / Threaded rods with the setting depth mark or fischer RG M I or fischer FIS IG down to the bottom of the hole, turning it slightly while doing so. No turning movement is permitted when using the DD-S / DD-E centering clips. After inserting the metal parts, excess mortar must be emerged around the anchor element.</p>
12	 <p>For overhead installations support the metal part with wedges (e.g. fischer centering wedges or fischer overhead clips).</p>	 <p>For push through installation fill the annular gap with mortar.</p>
13	 <p>Wait for the specified curing time t_{cure} see Table B10.2. The application with the anchor rod is shown as an example.</p>	 <p>14 Mounting the fixture $\max T_{inst}$ see Tables B3.1, B4.1 and B5.1.</p>
Option	 <p>After the minimum curing time is reached, the gap between metal part and fixture (annular clearance) may be filled with mortar via the fischer filling disc. Compressive strength $\geq 50 \text{ N/mm}^2$ (e.g. fischer injection mortars FIS HB, FIS SB, FIS V Plus, FIS EM Plus). ATTENTION: Using fischer filling disc reduces t_{fix} (usable length of the Anchor).</p>	

Installation reinforcing bars and fischer FRA

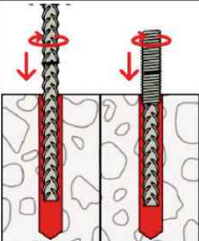
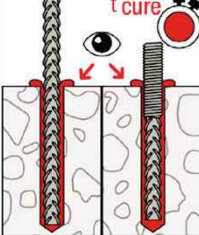
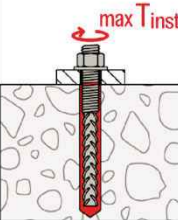
11	 <p>Only use clean and oil-free reinforcing bars or fischer FRA. Push the reinforcement bar or the fischer FRA with the setting depth mark into the filled hole up to the setting depth mark. Recommendation: Rotation back and forth of the reinforcement bar or the fischer FRA makes pushing easy.</p>	
	 <p>When the setting depth mark is reached, excess mortar must be emerged from the mouth of the drill hole. Wait for the specified curing time t_{cure} see Table B10.2.</p>	 <p>12 Mounting the fixture $\max T_{inst}$ see Table B7.1.</p>

fischer injection system FIS V Plus

Intended use
Installation instructions part 3

Annex B14

Appendix 23 / 41

Table C1.1: Characteristic resistance to steel failure under tension / shear loading of Anchor rods and Threaded rods

Anchor rod / Threaded rod		M6	M8	M10	M12	M16	M20	M24	M27	M30			
Characteristic resistance to steel failure under tension loading ¹⁾													
Characteristic resistance $N_{Rk,S}$	Steel zinc plated	Property class	4.8	[kN]	8,0	14,6(13,2)	23,2(21,4)	33,7	62,8	98,0	141,2	183,6	224,4
			5.8		10,1	18,3(16,6)	29,0(26,8)	42,1	78,5	122,5	176,5	229,5	280,5
			8.8		16,1	29,2(26,5)	46,4(42,8)	67,4	125,6	196,0	282,4	367,2	448,8
	Stainless steel R and high corrosion resistant steel HCR		50		10,1	18,3	29,0	42,1	78,5	122,5	176,5	229,5	280,5
			70		14,1	25,6	40,6	59,0	109,9	171,5	247,1	321,3	392,7
			80		16,1	29,2	46,4	67,4	125,6	196,0	282,4	367,2	448,8
Partial factors ¹⁾													
Partial factor $\gamma_{Ms,N}$	Steel zinc plated	Property class	4.8	[-]	1,50								
			5.8		1,50								
			8.8		1,50								
	Stainless steel R and high corrosion resistant steel HCR		50		2,86								
			70		1.87 / fischer HCR: 1.50 ³⁾								
			80		1,60								
Characteristic resistance to steel failure under shear loading ¹⁾													
without lever arm													
Characteristic resistance $V_{Rk,S}$	Steel zinc plated	Property class	4.8	[kN]	4,8	8,7(7,9)	13,9(12,8)	20,2	37,6	58,8	84,7	110,1	134,6
			5.8		6,0	10,9(9,9)	17,4(16,0)	25,2	47,1	73,5	105,9	137,7	168,3
			8.8		8,0	14,6(13,2)	23,2(21,4)	33,7	62,8	98,0	141,2	183,6	224,4
	Stainless steel R and high corrosion resistant steel HCR		50		5,0	9,1	14,5	21,0	39,2	61,2	88,2	114,7	140,2
			70		7,0	12,8	20,3	29,5	54,9	85,7	123,5	160,6	196,3
			80		8,0	14,6	23,2	33,7	62,8	98,0	141,2	183,6	224,4
Ductility factor	k ₇	[-]	1,0										
with lever arm													
Characteristic resistance $M_{Rk,S}$	Steel zinc plated	Property class	4.8	[Nm]	6,1	14,9(12,9)	29,9(26,5)	52,3	132,9	259,6	448,8	665,7	899,5
			5.8		7,6	18,7(16,1)	37,3(33,2)	65,4	166,2	324,6	561,0	832,2	1124,4
			8.8		12,2	29,9(25,9)	59,8(53,1)	104,6	265,9	519,3	897,6	1331,5	1799,0
	Stainless steel R and high corrosion resistant steel HCR		50		7,6	18,7	37,3	65,4	166,2	324,6	561,0	832,2	1124,4
			70		10,7	26,2	52,3	91,5	232,6	454,4	785,4	1165,0	1574,1
			80		12,2	29,9	59,8	104,6	265,9	519,3	897,6	1331,5	1799,0
Partial factors ²⁾													
Partial factor $\gamma_{Ms,V}$	Steel zinc plated	Property class	4.8	[-]	1,25								
			5.8		1,25								
			8.8		1,25								
	Stainless steel R and high corrosion resistant steel HCR		50		2,38								
			70		1.56 / fischer HCR: 1.25 ³⁾								
			80		1,33								

¹⁾ Values in brackets are valid for undersized threaded rods with smaller stress area A_s for hot dip galvanised threaded rods according to EN ISO 10684:2004+AC:2009.

²⁾ In absence of other national regulations.

³⁾ Only admissible for high corrosion resistant steel HCR, acc. to **Table A7.1**.

fischer injection system FIS V Plus

Performances

Characteristic resistance to steel failure under tension / shear loading of Anchor rods and Threaded rods

Annex C1

Appendix 24 / 41

Table C2.1: Characteristic resistance to steel failure under tension / shear loading of fischer RG M I									
fischer RG M I					M8	M10	M12	M16	M20
Characteristic resistance to steel failure under tension loading									
Characteristic resistance with Screw or Threaded / Anchor rod $N_{Rk,s}$	Steel zinc plated	Property class of Screw or Threaded / Anchor rod	5.8	[kN]	18,3	29,0	42,1	78,3	122,4
			8.8		29,2	46,4	67,4	106,7	180,2
	Stainless steel R and High corrosion resistant steel HCR		70		25,6	40,6	59,0	109,6	171,3
Partial factors ¹⁾									
Partial factor $\gamma_{Ms,N}$	Steel zinc plated	Property class of Screw or Threaded / Anchor rod	5.8	[-]	1,50				
			8.8		1,50				
	Stainless steel R and High corrosion resistant steel HCR		70		1,87 / fischer HCR: 1,50 ²⁾				
Characteristic resistance to steel failure under shear loading									
Without lever arm									
Characteristic resistance with Screw or Threaded / Anchor rod $V_{Rk,s}^0$	Steel zinc plated	Property class of Screw or Threaded / Anchor rod	5.8	[kN]	10,9	17,4	25,2	47,1	73,5
			8.8		14,6	23,2	33,7	62,8	98,0
	Stainless steel R and High corrosion resistant steel HCR		70		12,8	20,3	29,5	54,9	85,7
Ductility factor			k_7	[-]	1,0				
With lever arm									
Characteristic resistance with Screw or Threaded / Anchor rod $M_{Rk,s}^0$	Steel zinc plated	Property class of Screw or Threaded / Anchor rod	5.8	[Nm]	18,7	37,3	65,4	166,2	324,6
			8.8		29,9	59,8	104,6	265,9	519,3
	Stainless steel R and High corrosion resistant steel HCR		70		26,2	52,3	91,5	232,6	454,4
Partial factors ¹⁾									
Partial factor $\gamma_{Ms,V}$	Steel zinc plated	Property class of Screw or Threaded / Anchor rod	5.8	[-]	1,25				
			8.8		1,25				
	Stainless steel R and High corrosion resistant steel HCR		70		1,56 / fischer HCR: 1,25 ²⁾				
¹⁾ In absence of other national regulations ²⁾ Only admissible for high corrosion resistant steel HCR, acc. to Table A7.1 .									
fischer injection system FIS V Plus								Annex C2 Appendix 25 / 41	
Performances Characteristic resistance to steel failure under shear loading of fischer RG M I									

Table C3.1: Characteristic resistance to steel failure under tension / shear loading of fischer FIS IG

fischer FIS IG				M5	M6	M8	M10	M12	M16	M20	
Characteristic resistance to steel failure under tension loading											
Characteristic resistance with Screw or Threaded / Anchor rod $N_{Rk,s}$	Steel zinc plated	Property class of Screw or Threaded / Anchor rod	5.8	[kN]	7,1	10,1	18,3	29,0	42,1	78,3	122,4
			8.8		11,4	16,1	23,0	46,4	67,4	96,9	156,8
	Stainless steel R and High corrosion resistant steel HCR		70		9,9	14,1	25,6	40,6	59,0	109,6	171,3
Partial factors ¹⁾											
Partial factor $\gamma_{Ms,N}$	Steel zinc plated	Property class of Screw or Threaded / Anchor rod	5.8	[-]	1,50						
			8.8		1,50						
	Stainless steel R and High corrosion resistant steel HCR		70		1,87 / fischer HCR: 1,50 ²⁾						
Characteristic resistance to steel failure under shear loading											
Without lever arm											
Characteristic resistance with Screw or Threaded / Anchor rod $V_{Rk,s}$	Steel zinc plated	Property class of Screw or Threaded / Anchor rod	5.8	[kN]	4,3	6,0	10,9	17,4	25,2	47,1	73,5
			8.8		5,7	8,0	14,6	23,2	33,7	62,8	98,0
	Stainless steel R and High corrosion resistant steel HCR		70		5,0	7,0	12,8	20,3	29,5	54,9	85,7
Ductility factor			k_7	[-]	1,0						
With lever arm											
Characteristic resistance with Screw or Threaded / Anchor rod $M_{Rk,s}$	Steel zinc plated	Property class of Screw or Threaded / Anchor rod	5.8	[Nm]	4,5	7,6	18,7	37,3	65,4	166,2	324,6
			8.8		7,2	12,2	29,9	59,8	104,6	265,9	519,3
	Stainless steel R and High corrosion resistant steel HCR		70		6,3	10,7	26,2	52,3	91,5	232,6	454,4
Partial factors ¹⁾											
Partial factor $\gamma_{Ms,V}$	Steel zinc plated	Property class of Screw or Threaded / Anchor rod	5.8	[-]	1,25						
			8.8		1,25						
	Stainless steel R and High corrosion resistant steel HCR		70		1,56 / fischer HCR: 1,25 ²⁾						

¹⁾ In absence of other national regulations.

²⁾ Only admissible for high corrosion resistant steel HCR, acc. to **Table A7.1**

fischer injection system FIS V Plus

Performances

Characteristic resistance to steel failure under shear loading of fischer FIS IG

Annex C3

Appendix 26 / 41

Table C4.1: Characteristic resistance to steel failure under tension / shear loading of reinforcing bars

Nominal diameter of the bar	ϕ	8	10	12	14	16	20	25	28
Characteristic resistance to steel failure under tension loading									
Characteristic resistance	$N_{Rk,s}$	[kN]	$A_s \cdot f_{uk}^{1)}$						
Characteristic resistance to steel failure under shear loading									
Without lever arm									
Characteristic resistance	$V^0_{Rk,s}$	[kN]	$k_6^{2)}) \cdot A_s \cdot f_{uk}^{1)}$						
Ductility factor	k_7	[-]	1,0						
With lever arm									
Characteristic resistance	$M^0_{Rk,s}$	[Nm]	$1,2 \cdot W_{el} \cdot f_{uk}^{1)}$						
<p>¹⁾ f_{uk} respectively shall be taken from the specifications of the reinforcing bar. ²⁾ In accordance with EN 1992-4:2018 section 7.2.2.3.1: $k_6 = 0,6$ for fasteners made of carbon steel with $f_{uk} \leq 500 \text{ N/mm}^2$, $= 0,5$ for fasteners made of carbon steel with $500 \text{ N/mm}^2 < f_{uk} \leq 1000 \text{ N/mm}^2$, $= 0,5$ for fasteners made of stainless steel.</p>									

Table C4.2: Characteristic resistance to steel failure under tension / shear loading of fischer FRA

fischer FRA		M12	M16	M20	M24	
Characteristic resistance to steel failure under tension loading						
Characteristic resistance	$N_{Rk,s}$	[kN]	62,0	111,0	173,0	236,5
Partial factor¹⁾						
Partial factor	$\gamma_{Ms,N}$	[-]	1,4			
Characteristic resistance to steel failure under shear loading						
Without lever arm						
Characteristic resistance	$V^0_{Rk,s}$	[kN]	34,5	64,3	100,4	144,7
Ductility factor	k_7	[-]	1,0			
With lever arm						
Characteristic resistance	$M^0_{Rk,s}$	[Nm]	107,4	273,0	532,2	920,4
Partial factor¹⁾						
Partial factor	$\gamma_{Ms,V}$	[-]	1,5			

¹⁾ In absence of other national regulations.

Table C5.1: Characteristic resistance to concrete failure under tension / shear loading													
Size			All sizes										
Characteristic resistance to concrete failure under tension loading													
Installation factor		γ_{inst}	[-]		See annex C6 to C11 and C 17 to C18								
Factors for the compressive strength of concrete > C20/25													
Increasing factor ψ_c for cracked or uncracked concrete $\tau_{Rk(X,Y)} = \psi_c \cdot \tau_{Rk(C20/25)}$	C25/30		[-]	1,05									
	C30/37			1,10									
	C35/45			1,15									
	C40/50			1,19									
	C45/55			1,22									
	C50/60			1,26									
Splitting failure													
Edge distance	$h / h_{ef} \geq 2,0$		$C_{cr,sp}$	[mm]	1,0 h_{ef}			C12/15: 1,22 h_{ef}					
	$2,0 > h / h_{ef} > 1,3$				4,6 h_{ef} - 1,8 h			C12/15: 5,6 h_{ef} - 2,2 h					
	$h / h_{ef} \leq 1,3$				2,26 h_{ef}			C12/15: 2,75 h_{ef}					
Spacing		$S_{cr,sp}$	$2 C_{cr,sp}$										
Concrete failure													
Uncracked concrete		$k_{ucr,N}$	[-]	11,0									
Cracked concrete		$k_{cr,N}$		7,7									
Edge distance		$C_{cr,N}$	[mm]	1,5 h_{ef}									
Spacing		$S_{cr,N}$		$2 C_{cr,N}$									
Factors for sustained tension loading													
Temperature range			[-]		50 °C / 80 °C			72 °C / 120 °C					
Factor C12/15 and C16/20		Ψ_{sus}^0	[-]		0,68			0,70					
Factor from \geq C20/25		$\Psi_{sus}^0 = \Psi_{sus,100}^0$	[-]		0,76			0,78					
Characteristic resistance to concrete failure under shear loading													
Installation factor		γ_{inst}	[-]		1,0								
Concrete pry-out failure													
Factor for pry-out failure		k_8	[-]		2,0								
Concrete edge failure													
Effective length of fastener in shear loading		l_f	[mm]	for $d_{nom} \leq 24$ mm: min (h_{ef} ; 12 d_{nom}) for $d_{nom} > 24$ mm: min (h_{ef} ; 8 d_{nom} ; 300 mm)									
Calculation diameters													
Size			M5	M6	M8	M10	M12	M16	M20	M24	M27	M30	
Anchor rods and Threaded rods		d_{nom}	[mm]	-1)	6	8	10	12	16	20	24	27	30
fischer RG M I		d_{nom}		-1)	-1)	12	16	18	22	28	-1)	-1)	-1)
fischer FIS IG		d_{nom}		8	10	12	16	20	24	30	-1)	-1)	-1)
fischer FRA		d_{nom}		-1)	-1)	-1)	-1)	12	16	20	25	-1)	-1)
Size (nominal diameter of the bar)			ϕ	8	10	12	14	16	20	25	28		
Reinforcing bar		d_{nom}	[mm]	8	10	12	14	16	20	25	28		
1) Size of Anchor type not part of the assessment													
fischer injection system FIS V Plus									Annex C5 Appendix 28 / 41				
Performances Characteristic resistance to concrete failure under tension / shear loading													

Table C6.1: Characteristic resistance to combined pull-out and concrete failure for Anchor rods and Threaded rods and fischer FIS IG in hammer drilled holes; uncracked or cracked concrete C20/25; working life 50 years

Anchor rod / Threaded rod		M6	M8	M10	M12	M16	M20	M24	M27	M30			
fischer FIS IG		-	-	M5 M6	M8	M10	M12	M16	-	M20			
Combined pullout and concrete cone failure													
Calculation diameter	d	[mm]	6	8	10	12	16	20	24	27	30		
Uncracked concrete													
Characteristic bond resistance in uncracked concrete C20/25													
Hammer-drilling with standard drill bit or hollow drill bit (dry or wet concrete)													
Temperature range	I: 50 °C / 80 °C		$\tau_{Rk,ucr}$	[N/mm ²]	9,0	16,0	16,0	15,0	14,0	12,0	11,0	10,0	9,0
	II: 72 °C / 120 °C				6,5	15,0	14,0	13,0	12,0	11,0	9,0	8,0	8,0
Hammer-drilling with standard drill bit or hollow drill bit (water filled hole)													
Temperature range	I: 50 °C / 80 °C		$\tau_{Rk,ucr}$	[N/mm ²]	-1)	-1)	-1)	9,5	8,5	8,0	7,5	7,0	7,0
	II: 72 °C / 120 °C				-1)	-1)	-1)	7,5	7,0	6,5	6,0	6,0	6,0
Installation factors													
Dry or wet concrete	γ_{inst}	[-]	1,0										
Water filled hole	γ_{inst}	[-]	-1)	-1)	-1)	1,2							
Cracked concrete													
Characteristic bond resistance in cracked concrete C20/25													
Hammer-drilling with standard drill bit or hollow drill bit (dry or wet concrete)													
Temperature range	I: 50 °C / 80 °C		$\tau_{Rk,cr}$	[N/mm ²]	-1)	5,5	6,0	6,5	6,0	5,5	5,0	5,0	4,5
	II: 72 °C / 120 °C				-1)	4,5	5,0	6,0	5,5	5,0	4,5	4,0	4,0
Hammer-drilling with standard drill bit or hollow drill bit (water filled hole)													
Temperature range	I: 50 °C / 80 °C		$\tau_{Rk,cr}$	[N/mm ²]	-1)	-1)	-1)	5,0	5,0	4,5	4,0	3,5	3,5
	II: 72 °C / 120 °C				-1)	-1)	-1)	4,0	4,0	4,0	3,5	3,0	3,0
Installation factors													
Dry or wet concrete	γ_{inst}	[-]	-1)	1,0									
Water filled hole	γ_{inst}	[-]	-1)	-1)	-1)	1,2							
1) No performance assessed													

fischer injection system FIS V Plus

Performances

Characteristic resistance to combined pull-out and concrete failure for Anchor rod and Threaded rods; working life 50 years; concrete C20/25

Annex C6

Appendix 29 / 41

Table C7.1: Characteristic resistance to combined pull-out and concrete failure for Anchor rods, Threaded rods and fischer FIS IG in hammer drilled holes; uncracked or cracked concrete C20/25; working life 100 years

Anchor rod / Threaded rod		M6	M8	M10	M12	M16	M20	M24	M27	M30		
fischer FIS IG		-	-	M5 M6	M8	M10	M12	M16	-	M20		
Combined pullout and concrete cone failure												
Calculation diameter	d	[mm]	6	8	10	12	16	20	24	27	30	
Uncracked concrete												
Characteristic bond resistance in uncracked concrete C20/25												
<u>Hammer-drilling with standard drill bit or hollow drill bit (dry or wet concrete)</u>												
Temperature range	I: 50 °C / 80 °C		$\tau_{Rk,100,ucr}$ [N/mm ²]	- ¹⁾	16,0	16,0	15,0	14,0	12,0	11,0	10,0	9,0
	II: 72 °C / 120 °C			- ¹⁾	15,0	14,0	13,0	12,0	11,0	9,0	8,0	8,0
<u>Hammer-drilling with standard drill bit or hollow drill bit (water filled hole)</u>												
Temperature range	I: 50 °C / 80 °C		$\tau_{Rk,100,ucr}$ [N/mm ²]	- ¹⁾	- ¹⁾	- ¹⁾	9,5	8,5	8,0	7,5	7,0	7,0
	II: 72 °C / 120 °C			- ¹⁾	- ¹⁾	- ¹⁾	7,5	7,0	6,5	6,0	6,0	6,0
Installation factors												
Dry or wet concrete		γ_{inst}	[-]	- ¹⁾	1,0							
Water filled hole				- ¹⁾	- ¹⁾	- ¹⁾	1,2					
Cracked concrete												
Characteristic bond resistance in cracked concrete C20/25												
<u>Hammer-drilling with standard drill bit or hollow drill bit (dry or wet concrete)</u>												
Temperature range	I: 50 °C / 80 °C		$\tau_{Rk,100,cr}$ [N/mm ²]	- ¹⁾	5,0	5,5	5,5	5,5	5,5	5,0	5,0	4,5
	II: 72 °C / 120 °C			- ¹⁾	4,5	5,0	5,0	5,0	5,0	4,0	4,0	4,0
<u>Hammer-drilling with standard drill bit or hollow drill bit (water filled hole)</u>												
Temperature range	I: 50 °C / 80 °C		$\tau_{Rk,100,cr}$ [N/mm ²]	- ¹⁾	- ¹⁾	- ¹⁾	4,5	4,5	4,5	4,0	3,5	3,5
	II: 72 °C / 120 °C			- ¹⁾	- ¹⁾	- ¹⁾	4,0	4,0	4,0	3,5	3,0	3,0
Installation factors												
Dry or wet concrete		γ_{inst}	[-]	- ¹⁾	1,0							
Water filled hole				- ¹⁾	- ¹⁾	- ¹⁾	1,2					
¹⁾ No performance assessed												

fischer injection system FIS V Plus

Performances

Characteristic resistance to combined pull-out and concrete failure for Anchor rod and Threaded rods; working life 100 years; concrete C20/25

Annex C7

Appendix 30 / 41

Table C8.1: Characteristic resistance to combined pull-out and concrete failure for Anchor rods, Threaded rods and fischer FIS IG in hammer drilled holes; uncracked or cracked concrete C12/15 and C16/20; working life 50 years

Anchor rod / Threaded rod		M6	M8	M10	M12	M16	M20	M24	M27	M30		
fischer FIS IG		-	-	M5 M6	M8	M10	M12	M16	-	M20		
Combined pullout and concrete cone failure												
Calculation diameter	d	[mm]	6	8	10	12	16	20	24	27	30	
Uncracked concrete												
Characteristic bond resistance in uncracked concrete C12/15												
Hammer-drilling with standard drill bit or hollow drill bit (dry or wet concrete)												
Temperature range	I: 50 °C / 80 °C	$\tau_{Rk,ucr}$	[N/mm ²]	- ¹⁾	12,5	12	11,5	10,5	10,0	9,0	8,5	8,0
	II: 72 °C / 120 °C			- ¹⁾	9,5	9,0	8,5	8,0	7,5	7,0	6,5	6,5
Hammer-drilling with standard drill bit or hollow drill bit (water filled hole)												
Temperature range	I: 50 °C / 80 °C	$\tau_{Rk,ucr}$	[N/mm ²]	- ¹⁾	- ¹⁾	- ¹⁾	9,0	7,5	7,0	4,0	3,5	3,5
	II: 72 °C / 120 °C			- ¹⁾	- ¹⁾	- ¹⁾	7,0	6,0	5,5	3,0	3,0	2,5
Installation factors												
Dry or wet concrete		γ_{inst}	[-]	- ¹⁾	1,2							
Water filled hole				- ¹⁾	1,4							
Cracked concrete												
Characteristic bond resistance in cracked concrete C12/15												
Hammer-drilling with standard drill bit or hollow drill bit (dry or wet concrete)												
Temperature range	I: 50 °C / 80 °C	$\tau_{Rk,cr}$	[N/mm ²]	- ¹⁾	4,5	5,0	5,0	5,0	4,0	4,0	4,0	4,0
	II: 72 °C / 120 °C			- ¹⁾	3,5	3,5	3,5	3,5	3,0	3,0	3,0	3,0
Hammer-drilling with standard drill bit or hollow drill bit (water filled hole)												
Temperature range	I: 50 °C / 80 °C	$\tau_{Rk,cr}$	[N/mm ²]	- ¹⁾	- ¹⁾	- ¹⁾	4,0	3,5	3,0	2,0	2,0	2,0
	II: 72 °C / 120 °C			- ¹⁾	- ¹⁾	- ¹⁾	3,0	2,5	2,5	1,5	1,5	1,5
Installation factors												
Dry or wet concrete		γ_{inst}	[-]	- ¹⁾	1,2							
Water filled hole				- ¹⁾	1,4							

¹⁾ No performance assessed

fischer injection system FIS V Plus

Performances

Characteristic resistance to combined pull-out and concrete failure for Anchor rod and Threaded rods; working life 50 years; concrete C12/15

Annex C8

Appendix 31 / 41

Table C9.1: Characteristic resistance to combined pull-out and concrete failure for fischer RG M I in hammer drilled holes; uncracked concrete; working life 50 years

fischer RG M I			M8	M10	M12	M16	M20	
Combined pullout and concrete cone failure								
Calculation diameter	d	[mm]	12	16	18	22	28	
Uncracked concrete								
Characteristic bond resistance in uncracked concrete C20/25								
<u>Hammer-drilling with standard drill bit or hollow drill bit (dry or wet concrete)</u>								
Temperature range	I: 50 °C / 80 °C	$\tau_{Rk,ucr}$	[N/mm ²]	10,5	10,0	9,5	9,0	8,5
	II: 72 °C / 120 °C			9,0	8,0	8,0	7,5	7,0
<u>Hammer-drilling with standard drill bit or hollow drill bit (water filled hole)</u>								
Temperature range	I: 50 °C / 80 °C	$\tau_{Rk,ucr}$	[N/mm ²]	10,0	9,0	9,0	8,5	8,0
	II: 72 °C / 120 °C			7,5	6,5	6,5	6,0	6,0
Installation factors								
Dry or wet concrete		γ_{inst}	[-]	1,0				
Water filled hole				1,2				



Table C10.1: Characteristic resistance to combined pull-out and concrete failure for reinforcing bars in hammer drilled holes; uncracked or cracked concrete; working life 50 years

Nominal diameter of the bar		ϕ	8	10	12	14	16	20	25	28		
Combined pullout and concrete cone failure												
Calculation diameter		d	[mm]	8	10	12	14	16	20	25	28	
Uncracked concrete												
Characteristic bond resistance in uncracked concrete C20/25												
Hammer-drilling with standard drill bit or hollow drill bit (dry or wet concrete)												
Tem- perature range	I: 50 °C / 80 °C		$\tau_{Rk,ucr}$	[N/mm ²]	11,0	11,0	11,0	10,0	10,0	9,5	9,0	8,5
	II: 72 °C / 120 °C				9,5	9,5	9,0	8,5	8,5	8,0	7,5	7,0
Installation factor												
Dry or wet concrete		γ_{inst}	[-]	1,0								
Cracked concrete												
Characteristic bond resistance in cracked concrete C20/25												
Hammer-drilling with standard drill bit or hollow drill bit (dry or wet concrete)												
Tem- perature range	I: 50 °C / 80 °C		$\tau_{Rk,cr}$	[N/mm ²]	- ¹⁾	3,0	5,0	5,0	5,0	4,5	4,0	4,0
	II: 72 °C / 120 °C				- ¹⁾	3,0	4,5	4,5	4,5	4,0	3,5	3,5
Installation factor												
Dry or wet concrete		γ_{inst}	[-]	1,0								

¹⁾ No performance assessed

fischer injection system FIS V Plus

Performances

Characteristic resistance to combined pull-out and concrete failure for reinforcing bars; working life 50 years

Annex C10

Appendix 33 / 41

Table C11.1: Characteristic resistance to combined pull-out and concrete failure for fischer FRA in hammer drilled holes; uncracked or cracked concrete; working life 50 years

fischer FRA		M12	M16	M20	M24	
Combined pullout and concrete cone failure						
Calculation diameter	d [mm]	12	16	20	25	
Uncracked concrete						
Characteristic bond resistance in uncracked concrete C20/25						
<u>Hammer-drilling with standard drill bit or hollow drill bit (dry or wet concrete)</u>						
Temperature range	I: 50 °C / 80 °C	$\tau_{Rk,ucr}$ [N/mm ²]	11,0	10,0	9,5	9,5
	II: 72 °C / 120 °C		9,0	8,5	8,0	7,5
Installation factors						
Dry or wet concrete	γ_{inst}	[-]	1,0			
Cracked concrete						
Characteristic bond resistance in cracked concrete C20/25						
<u>Hammer-drilling with standard drill bit or hollow drill bit (dry or wet concrete)</u>						
Temperature range	I: 50 °C / 80 °C	$\tau_{Rk,cr}$ [N/mm ²]	5,0	5,0	4,5	4,0
	II: 72 °C / 120 °C		4,5	4,5	4,0	3,5
Installation factors						
Dry or wet concrete	γ_{inst}	[-]	1,0			
fischer injection system FIS V Plus					Annex C11 Appendix 34 / 41	
Performances Characteristic resistance to combined pull-out and concrete failure for fischer FRA; working life 50 years						

Table C12.1: Displacements for Anchor rods / Threaded rods or fischer FIS IG

Anchor rod / Threaded rods		M6	M8	M10	M12	M16	M20	M24	M27	M30
fischer FIS IG										
Displacement-Factors for tension loading¹⁾										
Uncracked concrete; Temperature range I, II										
δ_{N0} -Factor	[mm/(N/mm ²)]	0,09	0,09	0,09	0,10	0,10	0,10	0,10	0,12	0,12
$\delta_{N\infty}$ -Factor		0,10	0,10	0,10	0,12	0,12	0,12	0,12	0,13	0,13
Cracked concrete; Temperature range I, II										
δ_{N0} -Factor	[mm/(N/mm ²)]	- ³⁾	0,12	0,12	0,12	0,13	0,16	0,19	0,21	0,23
$\delta_{N\infty}$ -Factor		- ³⁾	0,25	0,27	0,30	0,30	0,30	0,35	0,35	0,40
Displacement-Factors for shear loading²⁾										
Uncracked or cracked concrete; Temperature range I, II										
δ_{V0} -Factor	[mm/kN]	0,11	0,11	0,11	0,10	0,10	0,09	0,09	0,08	0,07
$\delta_{V\infty}$ -Factor		0,12	0,12	0,12	0,11	0,11	0,10	0,10	0,09	0,09
1) Calculation of effective displacement: $\delta_{N0} = \delta_{N0}\text{-Factor} \cdot \tau$ $\delta_{N\infty} = \delta_{N\infty}\text{-Factor} \cdot \tau$ τ = acting bond strength under tension loading					2) Calculation of effective displacement: $\delta_{V0} = \delta_{V0}\text{-Factor} \cdot V$ $\delta_{V\infty} = \delta_{V\infty}\text{-Factor} \cdot V$ V = acting shear loading					
3) No performance assessed										

Table C12.2: Displacements for fischer RG M I

fischer RG M I		M8	M10	M12	M16	M20
Displacement-Factors for tension loading¹⁾						
Uncracked concrete; Temperature range I, II						
δ_{N0} -Factor	[mm/(N/mm ²)]	0,10	0,11	0,12	0,13	0,14
$\delta_{N\infty}$ -Factor		0,13	0,14	0,15	0,16	0,18
Displacement-Factors for shear loading²⁾						
Uncracked concrete; Temperature range I, II						
δ_{V0} -Factor	[mm/kN]	0,12	0,12	0,12	0,12	0,12
$\delta_{V\infty}$ -Factor		0,14	0,14	0,14	0,14	0,14
1) Calculation of effective displacement: $\delta_{N0} = \delta_{N0}\text{-Factor} \cdot \tau$ $\delta_{N\infty} = \delta_{N\infty}\text{-Factor} \cdot \tau$ τ = acting bond strength under tension loading			2) Calculation of effective displacement: $\delta_{V0} = \delta_{V0}\text{-Factor} \cdot V$ $\delta_{V\infty} = \delta_{V\infty}\text{-Factor} \cdot V$ V: acting shear loading			

fischer injection system FIS V Plus

Performances
Displacements for Anchor rods / Threaded rods, fischer FIS IG and fischer RG M I

Annex C12

Appendix 35 / 41

Table C13.1: Displacements for reinforcing bars

Nominal diameter of the bar ϕ		8	10	12	14	16	20	25	28
Displacement-Factors for tension loading¹⁾									
Uncracked concrete; Temperature range I, II									
δ_{N0} -Factor	[mm/(N/mm ²)]	0,09	0,09	0,10	0,10	0,10	0,10	0,10	0,11
$\delta_{N\infty}$ -Factor		0,10	0,10	0,12	0,12	0,12	0,12	0,12	0,13
Cracked concrete; Temperature range I, II									
δ_{N0} -Factor	[mm/(N/mm ²)]	- ³⁾	0,12	0,13	0,13	0,13	0,13	0,13	0,14
$\delta_{N\infty}$ -Factor		- ³⁾	0,27	0,30	0,30	0,30	0,30	0,30	0,35
Displacement-Factors for shear loading²⁾									
Uncracked or cracked concrete; Temperature range I, II									
δ_{V0} -Factor	[mm/kN]	0,11	0,11	0,10	0,10	0,10	0,09	0,09	0,08
$\delta_{V\infty}$ -Factor		0,12	0,12	0,11	0,11	0,11	0,10	0,10	0,09
1) Calculation of effective displacement: $\delta_{N0} = \delta_{N0}\text{-Factor} \cdot \tau$ $\delta_{N\infty} = \delta_{N\infty}\text{-Factor} \cdot \tau$ τ = acting bond strength under tension loading ³⁾ No performance assessed					2) Calculation of effective displacement: $\delta_{V0} = \delta_{V0}\text{-Factor} \cdot V$ $\delta_{V\infty} = \delta_{V\infty}\text{-Factor} \cdot V$ V: acting shear loading				

Table C13.2: Displacements for fischer FRA

fischer FRA		M12	M16	M20	M24
Displacement-Factors for tension loading¹⁾					
Uncracked concrete; Temperature range I, II					
δ_{N0} -Factor	[mm/(N/mm ²)]	0,10	0,10	0,10	0,10
$\delta_{N\infty}$ -Factor		0,12	0,12	0,12	0,13
Cracked concrete; Temperature range I, II					
δ_{N0} -Factor	[mm/(N/mm ²)]	0,12	0,13	0,13	0,13
$\delta_{N\infty}$ -Factor		0,30	0,30	0,30	0,35
Displacement-Factors for shear loading²⁾					
Uncracked or cracked concrete; Temperature range I, II					
δ_{V0} -Factor	[mm/kN]	0,10	0,10	0,09	0,09
$\delta_{V\infty}$ -Factor		0,11	0,11	0,10	0,10
1) Calculation of effective displacement: $\delta_{N0} = \delta_{N0}\text{-Factor} \cdot \tau$ $\delta_{N\infty} = \delta_{N\infty}\text{-Factor} \cdot \tau$ τ = acting bond strength under tension loading			2) Calculation of effective displacement: $\delta_{V0} = \delta_{V0}\text{-Factor} \cdot V$ $\delta_{V\infty} = \delta_{V\infty}\text{-Factor} \cdot V$ V: acting shear loading		

Table C14.1: Characteristic resistance to **steel failure under tension / shear loading of Anchor rods and Threaded rods** under seismic action performance category C1

Anchor rod / Threaded rod		M10	M12	M16	M20	M24	M27	M30		
Characteristic resistance to steel failure under tension loading ¹⁾										
Anchor rods and Threaded rods, performance category C1 ²⁾										
Characteristic resistance $N_{Rk,s,C1}$	Steel zinc plated	Property class	4.8	23,2(21,4)	33,7	62,8	98,0	141,2	183,6	224,4
			5.8	29,0(26,8)	42,1	78,5	122,5	176,5	229,5	280,5
			8.8	46,4(42,8)	67,4	125,6	196,0	282,4	367,2	448,8
	Stainless steel R and high corrosion resistant steel HCR		50	29,0	42,1	78,5	122,5	176,5	229,5	280,5
			70	40,6	59,0	109,9	171,5	247,1	321,3	392,7
			80	46,4	67,4	125,6	196,0	282,4	367,2	448,8
Characteristic resistance to steel failure under shear loading without lever arm ¹⁾										
Anchor rods, performance category C1 ²⁾										
Characteristic resistance $V_{Rk,s,C1}$	Steel zinc plated	Property class	4.8	13,9(12,8)	20,2	37,6	58,8	84,7	110,1	134,6
			5.8	17,4(16,0)	25,2	47,1	73,5	105,9	137,7	168,3
			8.8	23,2(21,4)	33,7	62,8	98,0	141,2	183,6	224,4
	Stainless steel R and high corrosion resistant steel HCR		50	14,5	21,0	39,2	61,2	88,2	114,7	140,2
			70	20,3	29,5	54,9	85,7	123,5	160,6	196,3
			80	23,2	33,7	62,8	98,0	141,2	183,6	224,4
Threaded rods, performance category C1 ²⁾										
Characteristic resistance $V_{Rk,s,C1}$	Steel zinc plated	Property class	4.8	9,7(9,0)	14,1	26,3	41,1	59,3	77,1	97,2
			5.8	12,1(11,2)	17,7	32,9	51,4	74,1	96,3	117,8
			8.8	16,2(15,0)	23,6	43,9	68,6	98,8	128,5	157,0
	Stainless steel R and high corrosion resistant steel HCR		50	10,1	14,7	27,4	42,8	61,7	80,3	98,1
			70	14,2	20,6	38,4	60,0	86,4	112,4	137,4
			80	16,2	23,6	43,9	68,6	98,8	128,5	157,0

¹⁾ Values in brackets are valid for undersized Threaded rods with smaller stress area A_s for hot dip galvanised Threaded rods according to EN ISO 10684:2004+AC:2009.

²⁾ Partial factors for performance category C1 see **Table C16.1**; for Anchor rods the factor for steel ductility is 1,0

fischer injection system FIS V Plus

Performances

Characteristic resistance to steel failure under tension / shear loading for Anchor rods and Threaded rods under seismic action (performance category C1)

Annex C14

Appendix 37 / 41

Table C15.1: Characteristic resistance to steel failure under tension / shear loading for Anchor rods and Threaded rods under seismic action performance category C2

Anchor rod / Threaded rod		M10	M12	M16	M20	M24	M27	M30		
Characteristic resistance to steel failure under tension loading										
Anchor rods and Threaded rods, performance category C2 ¹⁾										
Characteristic resistance $N_{Rk,s,C2}$	Steel zinc plated	Property class	4.8	-2)	30,3	56,5	88,2	-2)	-2)	-2)
			5.8	-2)	37,9	70,6	110,2	-2)	-2)	-2)
			8.8	-2)	60,6	113,0	176,4	-2)	-2)	-2)
	Stainless steel R and high corrosion resistant steel HCR	Property class	50	-2)	37,9	70,6	110,2	-2)	-2)	-2)
			70	-2)	53,1	98,9	154,3	-2)	-2)	-2)
			80	-2)	60,6	113,0	176,4	-2)	-2)	-2)
Characteristic resistance to steel failure under shear loading without lever arm										
Anchor rods, performance category C2 ¹⁾										
Characteristic resistance $V_{Rk,s,C2}$	Steel zinc plated	Property class	4.8	-2)	13,3	28,2	45,2	-2)	-2)	-2)
			5.8	-2)	16,6	35,3	56,5	-2)	-2)	-2)
			8.8	-2)	22,2	47,1	75,4	-2)	-2)	-2)
	Stainless steel R and high corrosion resistant steel HCR	Property class	50	-2)	13,9	29,4	47,1	-2)	-2)	-2)
			70	-2)	19,4	41,2	66,0	-2)	-2)	-2)
			80	-2)	22,2	47,1	75,4	-2)	-2)	-2)
Threaded rods, performance category C2 ¹⁾										
Characteristic resistance $V_{Rk,s,C2}$	Steel zinc plated	Property class	4.8	-2)	13,3	26,3	41,1	-2)	-2)	-2)
			5.8	-2)	16,6	32,9	51,4	-2)	-2)	-2)
			8.8	-2)	22,2	43,9	68,6	-2)	-2)	-2)
	Stainless steel R and high corrosion resistant steel HCR	Property class	50	-2)	13,9	27,4	42,8	-2)	-2)	-2)
			70	-2)	19,4	38,4	60,0	-2)	-2)	-2)
			80	-2)	22,2	43,9	68,6	-2)	-2)	-2)

¹⁾ Partial factors for performance category C2 see **Table C16.1**; for Anchor rods the factor for steel ductility is 1,0.

²⁾ No performance assessed.

fischer injection system FIS V Plus

Performances

Characteristic resistance to steel failure under tension / shear loading for Anchor rods and Threaded rods under seismic action (performance category C2)

Annex C15

Appendix 38 / 41

Table C16.1: Partial factors for Anchor rods, Threaded rods under seismic action performance category C1 or C2

Anchor rod / Threaded rod		M10	M12	M16	M20	M24	M27	M30	
Characteristic resistance to steel failure under tension loading ¹⁾									
Partial factor $\gamma_{Ms,N}$	Steel zinc plated	Property class	4.8	[-]	1,50				
					5.8	1,50			
					8.8	1,50			
	Stainless steel R and high corrosion resistant steel HCR				50	2,86			
					70	1,87 / fischer HCR: 1,50 ²⁾			
					80	1,60			
Characteristic resistance to steel failure under shear loading ¹⁾									
Partial factor $\gamma_{Ms,V}$	Steel zinc plated	Property class	4.8	[-]	1,25				
					5.8	1,25			
					8.8	1,25			
	Stainless steel R and high corrosion resistant steel HCR				50	2,38			
					70	1,56 / fischer HCR: 1,25 ²⁾			
					80	1,33			

¹⁾ In absence of other national regulations.

²⁾ Only admissible for high corrosion resistant steel HCR, acc. to **Table A7.1**.

fischer injection system FIS V Plus

Performances

Partial factors under seismic action (performance category C1 and C2) for Anchor rods and Threaded rods

Annex C16

Appendix 39 / 41

Table C17.1: Characteristic resistance to **combined pull-out and concrete failure** for **Anchor rods and Threaded rods** in hammer drilled holes under seismic action performance category **C1**, concrete \geq **C20/25**; **working life 50 and 100 years**

Anchor rod / Threaded rod		M10	M12	M16	M20	M24	M27	M30	
Combined pullout and concrete cone failure									
Characteristic bond resistance									
Hammer-drilling with standard drill bit or hollow drill bit (dry or wet concrete)									
Temperature range	I: 50 °C / 80 °C	$\tau_{Rk,C1}$ [N/mm ²]	4,5	5,5	5,5	5,5	4,5	4,0	4,0
	II: 72 °C / 120 °C		4,0	4,5	4,5	4,5	4,0	3,5	3,5
Hammer-drilling with standard drill bit or hollow drill bit (water filled hole)									
Temperature range	I: 50 °C / 80 °C	$\tau_{Rk,C1}$ [N/mm ²]	- ¹⁾	5,0	5,0	4,5	4,0	3,5	3,5
	II: 72 °C / 120 °C		- ¹⁾	4,0	4,0	4,0	3,5	3,0	3,0
Installation factors									
Dry or wet concrete	γ_{inst}	[-]	1,0						
Water filled hole			- ¹⁾	1,2					

¹⁾ No performance assessed.

fischer injection system FIS V Plus

Performances

Characteristic resistance under seismic action (performance category C1) for Anchor rods and Threaded rods, working life 50 and 100 years

Annex C17

Appendix 40 / 41

Table C18.1: Characteristic resistance to **combined pull-out and concrete failure** for **Anchor rods / Threaded rods** in hammer drilled holes under seismic action performance category **C2**; concrete \geq **C20/25**; working life **50 and 100 years**

Anchor rod / Threaded rod		M12	M16	M20	
Combined pullout and concrete cone failure					
Characteristic bond resistance					
<u>Hammer-drilling with standard drill bit or hollow drill bit (dry or wet concrete)</u>					
Temperature range	I: 50 °C / 80 °C	$\tau_{Rk,C2}$ [N/mm ²]	1,5	1,3	2,1
	II: 72 °C / 120 °C		1,3	1,2	1,9
<u>Hammer-drilling with standard drill bit or hollow drill bit (water filled hole)</u>					
Temperature range	I: 50 °C / 80 °C	$\tau_{Rk,C2}$ [N/mm ²]	1,3	1,1	1,8
	II: 72 °C / 120 °C		1,1	1,0	1,6
Installation factors					
Dry or wet concrete		γ_{inst} [-]	1,0		
Water filled hole			1,2		
Displacement-Factors for tension loading¹⁾					
$\delta_{N,C2(50\%)-Factor}$		[mm/(N/mm ²)]	0,20	0,13	0,21
$\delta_{N,C2(100\%)-Factor}$			0,38	0,18	0,24
Displacement-Factors for shear loading²⁾					
$\delta_{V,C2(50\%)-Factor}$		[mm/kN]	0,18	0,10	0,07
$\delta_{V,C2(100\%)-Factor}$			0,25	0,14	0,11

1) Calculation of effective displacement:

$$\delta_{N,C2(50\%)} = \delta_{N,C2(50\%)-Factor} \cdot \tau$$

$$\delta_{N,C2(100\%)} = \delta_{N,C2(100\%)-Factor} \cdot \tau$$

τ = acting bond strength under tension loading

2) Calculation of effective displacement:

$$\delta_{V,C2(50\%)} = \delta_{V,C2(50\%)-Factor} \cdot V$$

$$\delta_{V,C2(100\%)} = \delta_{V,C2(100\%)-Factor} \cdot V$$

V: acting shear loading

fischer injection system FIS V Plus

Performances

Characteristic resistance under seismic action (performance category C2) for Anchor rods; working life 50 and 100 years

Annex C18

Appendix 41 / 41