



PRESTANDEDEKLARATION

DoP 0231

för fischer injektionssystem FIS-V-Plus (Metallankare för användning i betong)

SV

1. <u>Produkttypens unika identifikationskod:</u>	DoP 0231		
2. <u>Avsedd användning/avsedda användningar:</u>	Infästning i efterhand i sprucken och osprucken betong.		
3. <u>Tillverkare:</u>	Se bilaga, särskilt bilagor B1- B12 fischerwerke GmbH & Co. KG, Otto-Hahn-Straße 15, 79211 Denzlingen, Tyskland		
4. <u>Tillverkarens representant:</u>	–		
5. <u>System för bedömning och fortlöpande kontroll av prestanda:</u>	1		
6. <u>Europeiskt bedömningsdokument:</u> Europeisk teknisk bedömning: Tekniskt bedömningsorgan: Anmält/anmälda organ:	EAD 330499-01-0601 Edition 04/2020 ETA-20/0603; 2020-11-13 DIBt- Deutsches Institut für Bautechnik 2873 TU Darmstadt		
7. <u>Angiven prestanda:</u> Mekanisk hållfasthet och stabilitet (BWR 1) Karakteristisk bärförmåga för spänning (för statisk och kvasi-statisk belastning):	Stålets motståndskraft: Motstånd mot kombinerat fel vid utdragnig och betongkon: Motstånd i betongkonen: Kantavstånd för att slippa sprickor under last: Kraftighet: Maximal vridkraft vid installation: Minsta kant- och axelavstånd:	Bilagor C1-C3 Bilagor C4-C9 Bilagor C4 Bilagor C4 Bilagor C4-C9,C14 Bilagor B3, B6, B8 Bilagor B3-B8	$E_s = 210\ 000\ \text{MPa}$
Karakteristisk bärförmåga för skjuvning (för statisk och kvasi-statisk belastning):	Motstånd i stålet: Motstånd mot fläkning: Motstånd mot skador i betong:	Bilagor C1- C3 Bilagor C4 Bilagor C4	
Karakteristiskt motstånd och Förskjutningar för seismiska prestandakategorier C1 och C2:	Motstånd mot draglast, förskjutningar, kategori C1: Motstånd mot draglast, förskjutningar, kategori C2: Motstånd mot tvärlast, förskjutningar, kategori C1: Motstånd mot tvärlast, förskjutningar, kategori C2: Faktor cirkulärt hål:	Bilagor C12-C14 Bilagor C12,C13,C15 Bilagor C12, C13 Bilagor C12,C13,C15 Bilagor C12	
Förflyttningar under kort- och långvarig belastning:	Förflyttningar under kort- och långvarig belastning:	Bilagor C10, C11	
Hygien, hälsa och miljö (BWR 3) Innehåll, frisläppning och / eller frisläppning av farliga ämnen:	NPD		



8. Lämplig teknisk dokumentation och/eller särskild teknisk dokumentation: -

Prestandan för ovanstående produkt överensstämmer med den angivna prestandan. Denna prestandadeklaration har utfärdats i enlighet med förordning (EU) nr 305/2011 på eget ansvar av den tillverkare som anges ovan.

Undertecknad på tillverkarens vägnar av:



Dr. Oliver Geibig, Managing Director Business Units & Engineering
Tumlingen, 2020-11-27



Jürgen Grün, Managing Director Chemistry & Quality

Denna DoP har förberetts på olika språk. I händelse av tvist om tolkningen ska den engelska versionen alltid råda.

Bilagan innehåller frivilliga och kompletterande information på engelska som överskrider (det specifika språkets) lagkrav.

Specific Part

1 Technical description of the product

The "fischer Injection system FIS V Plus" is a bonded anchor consisting of a cartridge with injection mortar according to Annex A 4 and a steel element according to Annex A 1 to A 3.

The steel element is placed into a drilled hole filled with injection mortar and is anchored via the bond between metal part, injection mortar and concrete.

The product description is given in Annex A.

2 Specification of the intended use in accordance with the applicable European Assessment Document

The performances given in Section 3 are only valid if the anchor is used in compliance with the specifications and conditions given in Annex B.

The verifications and assessment methods on which this European Technical Assessment is based lead to the assumption of a working life of the anchor of at least 50 and/or 100 years. The indications given on the working life cannot be interpreted as a guarantee given by the producer, but are to be regarded only as a means for choosing the right products in relation to the expected economically reasonable working life of the works.

3 Performance of the product and references to the methods used for its assessment

3.1 Mechanical resistance and stability (BWR 1)

Essential characteristic	Performance
Characteristic resistance to tension load (static and quasi-static loading)	See Annex C 1, C 2, C 4 to C 9, B 4, B 5
Characteristic resistance to shear load (static and quasi-static loading)	See Annex C 1 to C 3
Displacements under short-term and long-term loading	See Annex C 10 to C 11
Characteristic resistance and displacements for seismic performance categories C1 and C2	See Annex C 12 to C 15

3.2 Hygiene, health and the environment (BWR 3)

Essential characteristic	Performance
Content, emission and/or release of dangerous substances	No performance assessed

4

Assessment and verification of constancy of performance (AVCP) system applied, with reference to its legal base

In accordance with the European Assessment Document EAD 330499-01-0601 the applicable European legal act is: [96/582/EC].

The system to be applied is: 1

Installation conditions part 1

fischer anchor rod

Pre-positioned installation

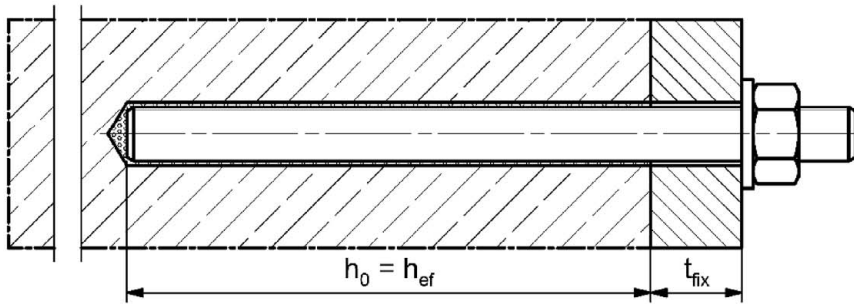

Push through installation (annular gap filled with mortar)

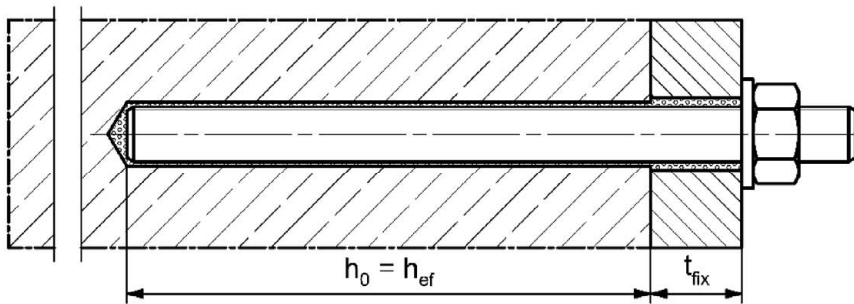

Pre-positioned or push through installation with subsequently injected fischer filling disc (annular gap filled with mortar)

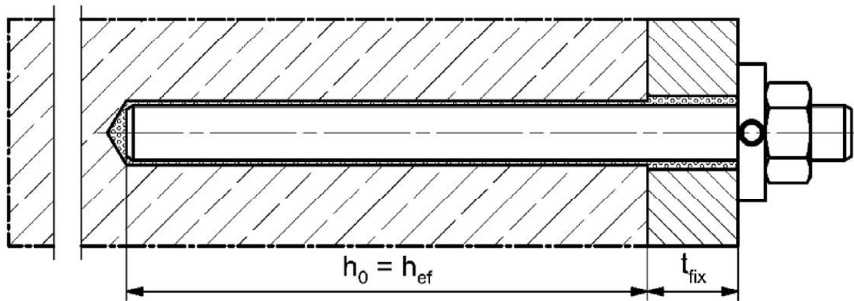

Figures not to scale

h_0 = drill hole depth

h_{ef} = effective embedment depth

t_{fix} = thickness of fixture

fischer injection system FIS V Plus

Product description
Installation conditions part 1

Annex A 1

Appendix 3 / 35

Installation conditions part 2

fischer internal threaded anchor RG MI

Pre-positioned installation

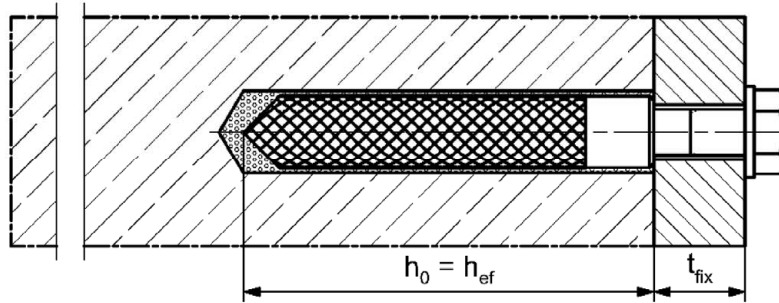

Pre-positioned installation with subsequently injected fischer filling disc (annular gap filled with mortar)

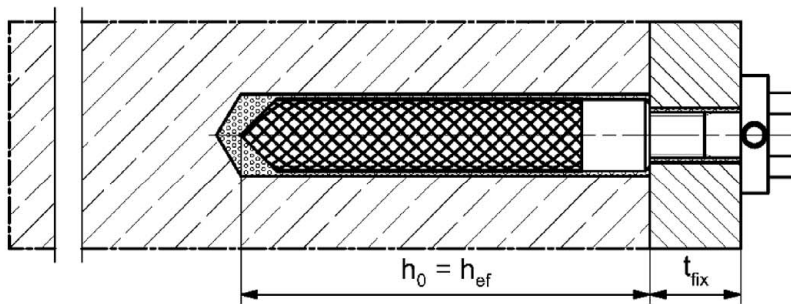

Figures not to scale

h_0 = drill hole depth

h_{ef} = effective embedment depth

t_{fix} = thickness of fixture

fischer injection system FIS V Plus

Product description
Installation conditions part 2

Annex A 2

Appendix 4 / 35

Installation conditions part 3

Reinforcing bar

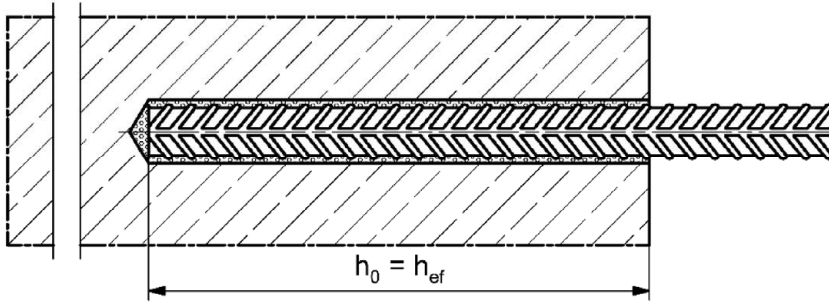

fischer rebar anchor FRA

Pre-positioned installation

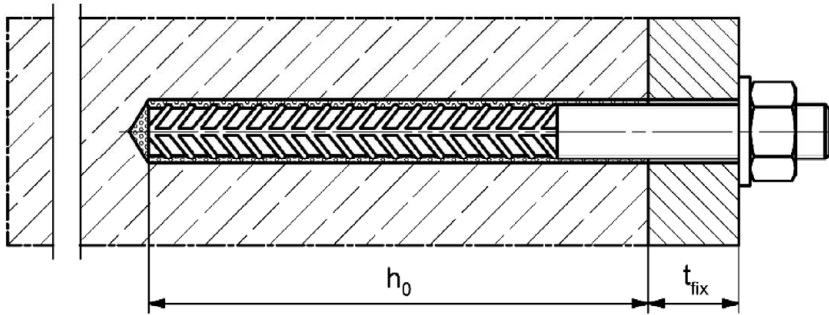

Push through installation (annular gap filled with mortar)

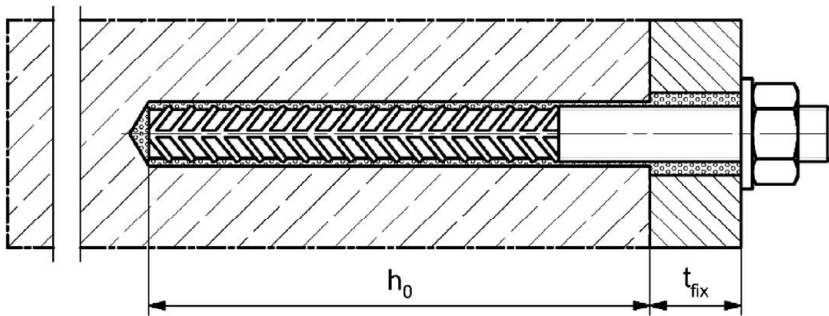

Figures not to scale

h_0 = drill hole depth

h_{ef} = effective embedment depth

t_{fix} = thickness of fixture

fischer injection system FIS V Plus

Product description
Installation conditions part 3

Annex A 3

Appendix 5 / 35

Overview system components part 1

Injection cartridge (shuttle cartridge) with sealing cap; Sizes: 350 ml, 360 ml, 390 ml, 550 ml, 1100 ml, 1500 ml

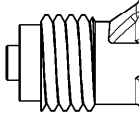
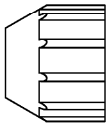

Imprint: fischer FIS V Plus or FIS VW Plus High Speed or FIS VS Plus Low Speed, processing notes, shelf-life, piston travel scale (optional), curing times and processing times (depending on temperature), hazard code, size, volume/weight

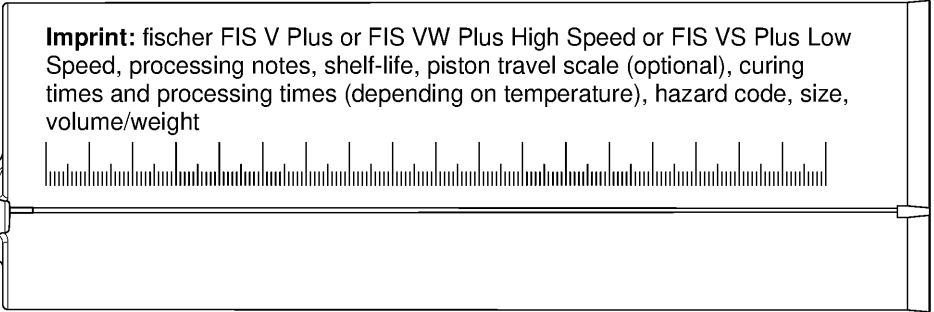

Injection cartridge (coaxial cartridge) with sealing cap; Sizes: 100 ml, 150 ml, 300 ml, 380 ml, 400 ml, 410 ml

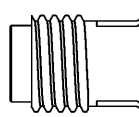
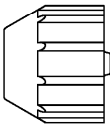

Imprint: fischer FIS V Plus or FIS VW Plus High Speed or FIS VS Plus Low Speed, processing notes, shelf-life, piston travel scale (optional), curing times and processing times (depending on temperature), hazard code, size, volume/weight

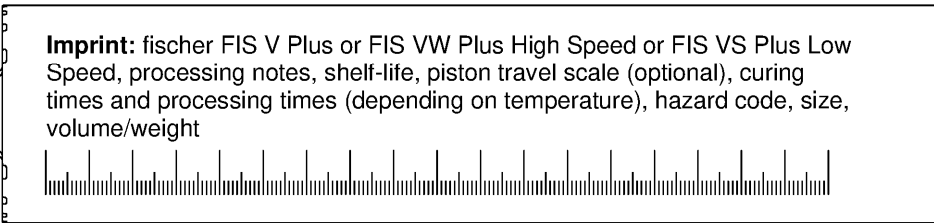

Static mixer FIS MR Plus for injection cartridges up to 410 ml

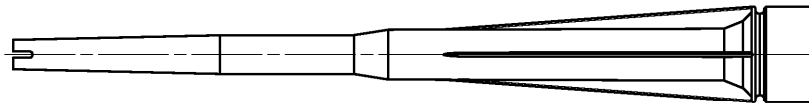

Static mixer FIS UMR for injection cartridges from 550 ml

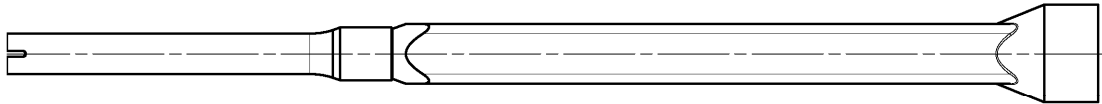

**Injection adapter and extension tube Ø 9 for static mixer FIS MR Plus;
Injection adapter and extension tube Ø 9 or Ø 15 for static mixer FIS UMR**

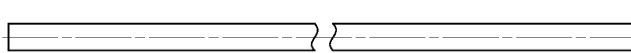
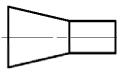

Cleaning brush BS



Blow-out pump

AB G:



ABP:



Figures not to scale

fischer injection system FIS V Plus

Product description

Overview system components part 1;
cartridges / static mixer / accessories

Annex A 4

Appendix 6 / 35

Overview system components part 2

fischer anchor rod

Size: M6, M8, M10, M12, M16, M20, M24, M27, M30

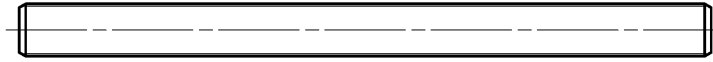

fischer internal threaded anchor RG MI

Size: M8, M10, M12, M16, M20



Screw / threaded rod / washer / hexagon nut

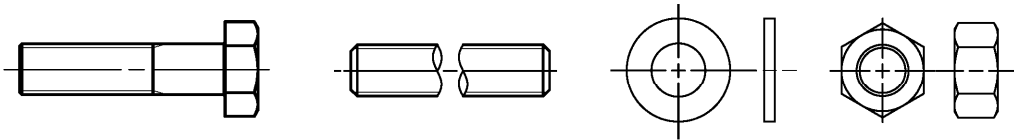

fischer filling disc with injection adapter

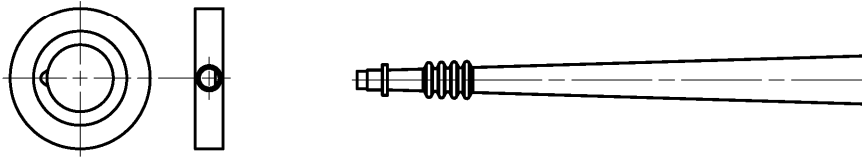

Reinforcing bar

Nominal diameter: $\phi 8$, $\phi 10$, $\phi 12$, $\phi 14$, $\phi 16$, $\phi 20$, $\phi 25$, $\phi 28$



fischer rebar anchor FRA

Size: M12, M16, M20, M24



Figures not to scale

fischer injection system FIS V Plus

Product description

Overview system components part 2;
metal parts, injection adapter

Annex A 5

Appendix 7 / 35

Table A6.1: Materials

Part	Designation	Material		
1	Injection cartridge	Mortar, hardener, filler		
	Steel grade	Steel	Stainless steel R	High corrosion resistant steel HCR
		zinc plated	acc. to EN 10088-1:2014 Corrosion resistance class CRC III acc. to EN 1993-1-4:2015	acc. to EN 10088-1:2014 Corrosion resistance class CRC V acc. to EN 1993-1-4:2015
2	Anchor rod	Property class 4.8, 5.8 or 8.8; EN ISO 898-1:2013 zinc plated $\geq 5 \mu\text{m}$, ISO 4042:2018/Zn5/An(A2K) or hot dip galvanised $\geq 40 \mu\text{m}$ EN ISO 10684:2004 $f_{uk} \leq 1000 \text{ N/mm}^2$ $A_5 > 12\%$ fracture elongation	Property class 50, 70 or 80 EN ISO 3506-1:2009 1.4401; 1.4404; 1.4578; 1.4571; 1.4439; 1.4362; 1.4062, 1.4662, 1.4462; EN 10088-1:2014 $f_{uk} \leq 1000 \text{ N/mm}^2$ $A_5 > 12\%$ fracture elongation	Property class 50 or 80 EN ISO 3506-1:2009 or property class 70 with $f_{yk} = 560 \text{ N/mm}^2$ 1.4565; 1.4529; EN 10088-1:2014 $f_{uk} \leq 1000 \text{ N/mm}^2$ $A_5 > 12\%$ fracture elongation
		Fracture elongation $A_5 > 8\%$, for applications without requirements for seismic performance category C2		
3	Washer ISO 7089:2000	zinc plated $\geq 5 \mu\text{m}$, ISO 4042:2018/Zn5/An(A2K) or hot dip galvanised $\geq 40 \mu\text{m}$ EN ISO 10684:2004	1.4401; 1.4404; 1.4578; 1.4571; 1.4439; 1.4362; EN 10088-1:2014	1.4565; 1.4529; EN 10088-1:2014
4	Hexagon nut	Property class 4, 5 or 8; EN ISO 898-2:2012 zinc plated $\geq 5 \mu\text{m}$, ISO 4042:2018/Zn5/An(A2K) or hot dip galvanised $\geq 40 \mu\text{m}$ EN ISO 10684:2004	Property class 50, 70 or 80 EN ISO 3506-1:2009 1.4401; 1.4404; 1.4578; 1.4571; 1.4439; 1.4362; EN 10088-1:2014	Property class 50, 70 or 80 EN ISO 3506-1:2009 1.4565; 1.4529; EN 10088-1:2014
5	fischer internal threaded anchor RG MI	Property class 5.8 ISO 898-1:2013 zinc plated $\geq 5 \mu\text{m}$, ISO 4042:2018/Zn5/An(A2K)	Property class 70 EN ISO 3506-1:2009 1.4401; 1.4404; 1.4578; 1.4571; 1.4439; 1.4362; EN 10088-1:2014	Property class 70 EN ISO 3506-1:2009 1.4565; 1.4529; EN 10088-1:2014
6	Commercial standard screw or threaded rod for fischer internal threaded anchor RG MI	Property class 5.8 or 8.8; EN ISO 898-1:2013 zinc plated $\geq 5 \mu\text{m}$, ISO 4042:2018/Zn5/An(A2K) $A_5 > 8\%$ fracture elongation	Property class 70 EN ISO 3506-1:2009 1.4401; 1.4404; 1.4578; 1.4571; 1.4439; 1.4362; EN 10088-1:2014 $A_5 > 8\%$ fracture elongation	Property class 70 EN ISO 3506-1:2009 1.4565; 1.4529; EN 10088-1:2014 $A_5 > 8\%$ fracture elongation
7	fischer filling disc similar to DIN 6319-G	zinc plated $\geq 5 \mu\text{m}$, ISO 4042:2018/Zn5/An(A2K) or hot dip galvanised $\geq 40 \mu\text{m}$ EN ISO 10684:2004	1.4401; 1.4404; 1.4578; 1.4571; 1.4439; 1.4362; EN 10088-1:2014	1.4565; 1.4529; EN 10088-1:2014
8	Reinforcing bar EN 1992-1-1:2004 and AC:2010, Annex C	Bars and de-coiled rods, class B or C with f_{yk} and k according to NDP or NCL of according to EN 1992-1-1:2004/NA $f_{tk} = f_{tk} = k \cdot f_{yk}$		
9	fischer rebar anchor FRA	Rebar part: Bars and de-coiled rods class B or C with f_{yk} and k according to NDP or NCL of EN 1992-1-1:2004+AC:2010 $f_{uk} = f_{tk} = k \cdot f_{yk}$	Threaded part: Property class 70 or 80 EN ISO 3506-1:2009 1.4401, 1.4404, 1.4571, 1.4578, 1.4439, 1.4362, 1.4062 acc. to EN 10088-1:2014 Corrosion resistance class CRC III acc. to EN 1993-1-4:2015 1.4565; 1.4529 acc. to EN 10088-1:2014 Corrosion resistance class CRC V acc. to EN 1993-1-4:2015	







fischer injection system FIS V Plus

Product description
Materials**Annex A 6**

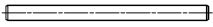
Appendix 8 / 35

Specifications of intended use (part 1)

Table B1.1: Overview use and performance categories

		FIS V Plus with ...							
		Anchor rod 	fischer internal threaded anchor RG MI 	Reinforcing bar 	fischer rebar anchor FRA 				
Hammer drilling with standard drill bit 	all sizes								
Hammer drilling with hollow drill bit  (fischer „FHD“, Heller „Duster Expert“, Bosch „Speed Clean“, Hilti „TE-CD, TE-YD“, DreBo „D-Plus“, DreBo „D-Max“)	Nominal drill bit diameter (d ₀) 12 mm to 35 mm								
Static and quasi static load, in	uncracked concrete	all sizes	Tables: C1.1 C4.1 C5.1 C6.1 C10.1	all sizes	Tables: C2.1 C4.1 C7.1 C10.2	all sizes	Tables: C3.1 C4.1 C8.1 C11.1	all sizes	Tables: C3.2 C4.1 C9.1 C11.2
	cracked concrete	M8 to M30		..2)		φ 10 to φ 28			
Seismic performance category	C1 ¹⁾	M10 to M30	Tables: C12.1 C13.1 C14.1	..2)		..2)		..2)	
	C2 ¹⁾	M12 M16 M20	Tables: C12.1 C13.1 C15.1						
Use category	I1 dry or wet concrete	all sizes							
	I2 water filled hole	M12 to M30		all sizes		..2)		..2)	
Installation direction	D3 (downward and horizontal and upwards (e.g. overhead) installation)								
Installation temperature	T _{i,min} = -10 °C to T _{i,max} = +40 °C								
In-service temperature	Temperature range I	-40 °C to +80 °C			(max. short term temperature +80 °C; max. long term temperature +50 °C)				
	Temperature range II	-40 °C to +120 °C			(max. short term temperature +120 °C; max. long term temperature +72 °C)				

¹⁾ Not for FIS VW Plus High Speed and FIS VS Plus Low Speed

²⁾ No performance assessed

fischer injection system FIS V Plus

Intended use
Specifications (part 1)

Annex B 1

Appendix 9 / 35

Specifications of intended use (part 2)

Base materials:

- Compacted reinforced or unreinforced normal weight concrete without fibres of strength classes C20/25 to C50/60 according to EN 206:2013+A1:2016

Use conditions (Environmental conditions):

- Structures subject to dry internal conditions (zinc coated steel, stainless steel or high corrosion resistant steel).
- For all other conditions according to EN1993-1-4:2015 corresponding to corrosion resistance classes to Annex A 6 Table A6.1.

Design:

- Anchorages have to be designed by a responsible engineer with experience of concrete anchor design.
- Verifiable calculation notes and drawings are to be prepared taking account of the loads to be anchored. The position of the anchor is indicated on the design drawings (e. g. position of the anchor relative to reinforcement or to supports, etc.).
- Anchorages are designed in accordance with: EN 1992-4:2018 and EOTA Technical Report TR 055, Edition February 2018.

Installation:

- Anchor installation is to be carried out by appropriately qualified personnel and under the supervision of the person responsible for technical matters of the site
- In case of aborted hole: The hole shall be filled with mortar
- Anchorage depth should be marked and adhered to on installation
- Overhead installation is allowed

fischer injection system FIS V Plus

Intended use
Specifications (part 2)

Annex B 2

Appendix 10 / 35

Table B3.1: Installation parameters for anchor rods ¹⁾

Anchor rods		Thread	M6	M8	M10	M12	M16	M20	M24	M27	M30	
Width across flats	SW	[mm]	10	13	17	19	24	30	36	41	46	
Nominal drill hole diameter	d ₀		8	10	12	14	18	24	28	30	35	
Drill hole depth	h ₀		h ₀ = h _{ef}									
Effective embedment depth	h _{ef, min}		50	60	60	70	80	90	96	108	120	
	h _{ef, max}		72	160	200	240	320	400	480	540	600	
Minimum spacing and minimum edge distance			S _{min} = C _{min}	40	40	45	55	65	85	105	125	140
Diameter of the clearance hole of the fixture	pre-positioned installation d _f		7	9	12	14	18	22	26	30	33	
	push through installation d _f		9	12	14	16	20	26	30	33	40	
Minimum thickness of concrete member	h _{min}		h _{ef} + 30 (≥100)					h _{ef} + 2d ₀				
Maximum installation torque	max T _{inst}		[Nm]	5	10	20	40	60	120	150	200	300

¹⁾ minimum spacing and minimum edge distance see Annex B 4

fischer anchor rod



Marking (on random place) fischer anchor rod:

Steel zinc plated PC ¹⁾ 8.8	• or +	Steel hot-dip PC ¹⁾ 8.8	•
High corrosion resistant steel HCR PC ¹⁾ 50	•	High corrosion resistant steel HCR PC ¹⁾ 70	-
High corrosion resistant steel HCR PC ¹⁾ 80	(Stainless steel R property class 50	~
Stainless steel R property class 80	*		

Alternatively: Colour coding according to DIN 976-1: 2016

¹⁾ PC = property class

Installation conditions:

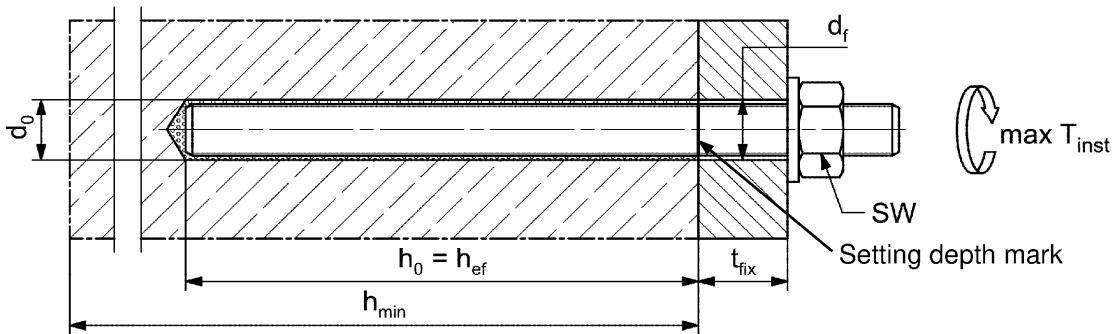

Commercial standard threaded rods, washers and hexagon nuts may also be used if the following requirements are fulfilled:

- Materials, dimensions and mechanical properties according to Annex A 6, Table A6.1
- Inspection certificate 3.1 according to EN 10204:2004, the documents have to be stored
- Setting depth is marked

Figures not to scale

fischer injection system FIS V Plus

Intended use
Installation parameters anchor rods

Annex B 3

Appendix 11 / 35

Table B4.1: Minimum spacing and minimum edge distance for anchor rods, reinforcing bars and fischer rebar anchor FRA

Anchor rods		M6	M8	M10	M12	-	M16
Reinforcing bars / FRA (nominal diameter)	ϕ	-	8	10	12	14	16
Minimum edge distance							
Uncracked / cracked concrete	C_{min}	[mm]	40	40	45	45	50
Minimum spacing	S_{min}		according to Annex B 5				
Minimum spacing							
Uncracked / cracked concrete	S_{min}	[mm]	40	40	45	55	60
Minimum edge distance	C_{min}		according to Annex B 5				
Required projecting area							
Uncracked concrete	$A_{sp,req}$	[1000 mm ²]	8,0	8,0	13,0	22,0	23,0
Cracked concrete			6,5	6,5	10	16,5	17,5
Anchor rods		M20	M24	-	M27	-	M30
Reinforcing bars / FRA (nominal diameter)	ϕ	20	-	25	-	28	-
Minimum edge distance							
Uncracked / cracked concrete	C_{min}	[mm]	55	60	75	75	80
Minimum spacing	S_{min}		according to Annex B 5				
Minimum spacing							
Uncracked / cracked concrete	S_{min}	[mm]	85	105	120	120	140
Minimum edge distance	C_{min}		according to Annex B 5				
Required projecting area							
Uncracked concrete	$A_{sp,req}$	[1000 mm ²]	38,5	40	47,5	47,5	64
Cracked concrete			29,5	30,5	36,5	36,5	49

Splitting failure for minimum edge distance and spacing in dependence of the effective embedment depth h_{ef} .

For the calculation of minimum spacing and minimum edge distance of anchors in combination with different embedment depths and thicknesses of concrete members the following equation shall be fulfilled:

$$A_{sp,req} < A_{sp,t}$$

$A_{sp,req}$ = required projecting area

$A_{sp,t} = A_{sp,ef}$ = effective projecting area (according to Annex B 5)

fischer injection system FIS V Plus

Intended use

Minimum spacing and edge distance for anchor rods, reinforcing bars and fischer rebar anchor FRA

Annex B 4

Table B5.1: Effective projecting area $A_{sp,t}$ with concrete member thickness $h > h_{ef} + 1,5 \cdot c$ and $h \geq h_{min}$

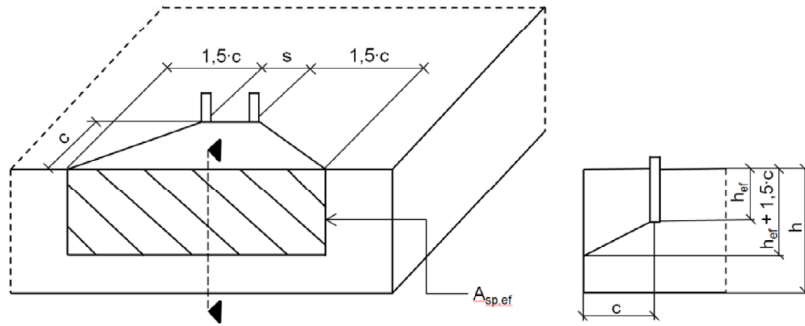

Single anchor	$A_{sp,t} = (3 \cdot c) \cdot (h_{ef} + 1,5 \cdot c)$	[mm ²]	with $c \geq c_{min}$
Group of anchors with $s > 3 \cdot c$	$A_{sp,t} = (6 \cdot c) \cdot (h_{ef} + 1,5 \cdot c)$	[mm ²]	
Group of anchors with $s \leq 3 \cdot c$	$A_{sp,t} = (3 \cdot c + s) \cdot (h_{ef} + 1,5 \cdot c)$	[mm ²]	with $c \geq c_{min}$ and $s \geq s_{min}$

Table B5.2: Effekive projecting area $A_{sp,t}$ with concrete member thickness $h \leq h_{ef} + 1,5 \cdot c$ and $h \geq h_{min}$

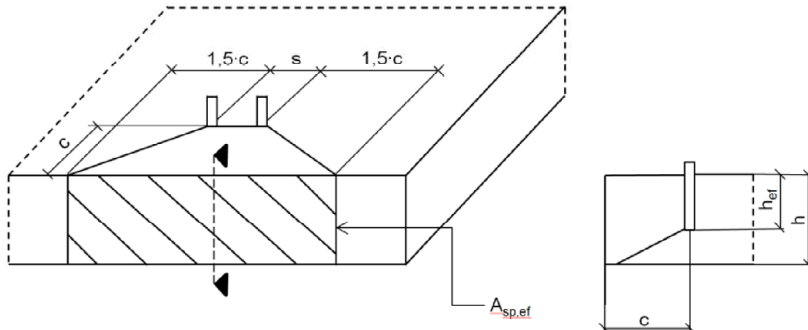

Single anchor	$A_{sp,t} = 3 \cdot c \cdot \text{existing } h$	[mm ²]	with $c \geq c_{min}$
Group of anchors with $s > 3 \cdot c$	$A_{sp,t} = 6 \cdot c \cdot \text{existing } h$	[mm ²]	
Group of anchors with $s \leq 3 \cdot c$	$A_{sp,t} = (3 \cdot c + s) \cdot \text{existing } h$	[mm ²]	with $c \geq c_{min}$ and $s \geq s_{min}$

Edge distance and axial spacing shall be rounded up to at least 5 mm

Figures not to scale

fischer injection system FIS V Plus

Intended use

Minimum thickness of concrete member for anchor rods and reinforcing bars, minimum spacing and edge distance

Annex B 5

Appendix 13 / 35

Table B6.1: Installation parameters for **fischer internal threaded anchors RG MI**

Internal threaded anchors RG MI		Thread	M8	M10	M12	M16	M20
Diameter of anchor	$d_{nom} = d_H$	[mm]	12	16	18	22	28
Nominal drill hole diameter	d_0		14	18	20	24	32
Drill hole depth	h_0		$h_0 = h_{ef} = L_H$				
Effective embedment depth ($h_{ef} = L_H$)	h_{ef}		90	90	125	160	200
Minimum spacing and minimum edge distance	s_{min} = c_{min}		55	65	75	95	125
Diameter of clearance hole in the fixture	d_f		9	12	14	18	22
Minimum thickness of concrete member	h_{min}		120	125	165	205	260
Maximum screw-in depth	$l_{E,max}$		18	23	26	35	45
Minimum screw-in depth	$l_{E,min}$		8	10	12	16	20
Maximum installation torque	$\max T_{inst}$	[Nm]	10	20	40	80	120

fischer internal threaded anchor RG MI

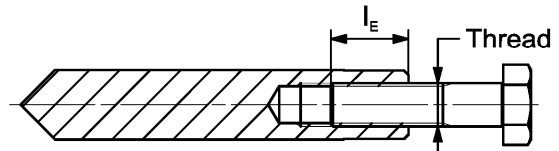
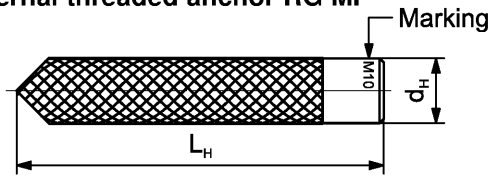

Marking:

Anchor size e. g.: **M10**

Stainless steel → additional **R**; e.g.: **M10 R**

High corrosion resistant steel → additional **HCR**; e.g.: **M10 HCR**

Retaining bolt or threaded rods (including nut and washer) must comply with the appropriate material and strength class of Annex A 6, Table A6.1

Installation conditions:

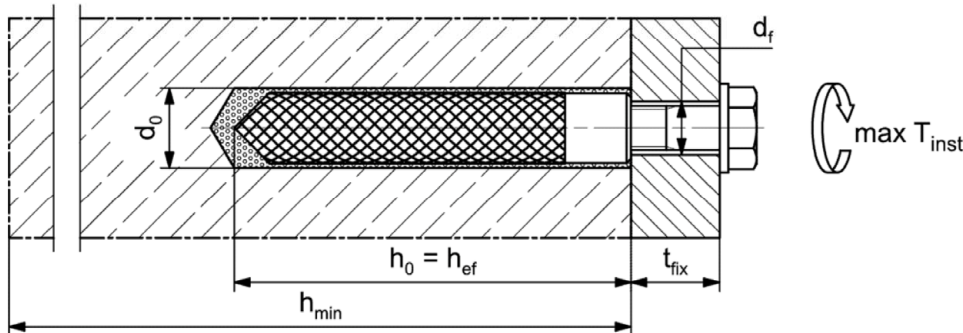

Figures not to scale

fischer injection system FIS V Plus

Intended use

Installation parameters internal threaded anchors RG MI

Annex B 6

Appendix 14 / 35

Table B7.1: Installation parameters for reinforcing bars ¹⁾

Nominal diameter of the bar		ϕ	8 ²⁾		10 ²⁾		12 ²⁾		14	16	20	25	28
Nominal drill hole diameter	d_0	[mm]	10	12	12	14	14	16	18	20	25	30	35
Drill hole depth	h_0		$h_0 = h_{ef}$										
Effective embedment depth	$h_{ef,min}$		60	60	70	75	80	90	100	112			
	$h_{ef,max}$		160	200	240	280	320	400	500	560			
Minimum spacing and minimum edge distance	s_{min} = c_{min}		40	45	55	60	65	85	110	130			
Minimum thickness of concrete member	h_{min}	$h_{ef} + 30$ (≥ 100)					$h_{ef} + 2d_0$						

¹⁾ minimum spacing and minimum edge distance see Annex B 4

²⁾ Both drill hole diameters can be used

Reinforcing bar



- The minimum value of related rib area $f_{R,min}$ must fulfil the requirements of EN 1992-1-1:2004+AC:2010
- The rib height must be within the range: $0,05 \cdot \phi \leq h_{rib} \leq 0,07 \cdot \phi$
(ϕ = Nominal diameter of the bar, h_{rib} = rib height)

Installation conditions:

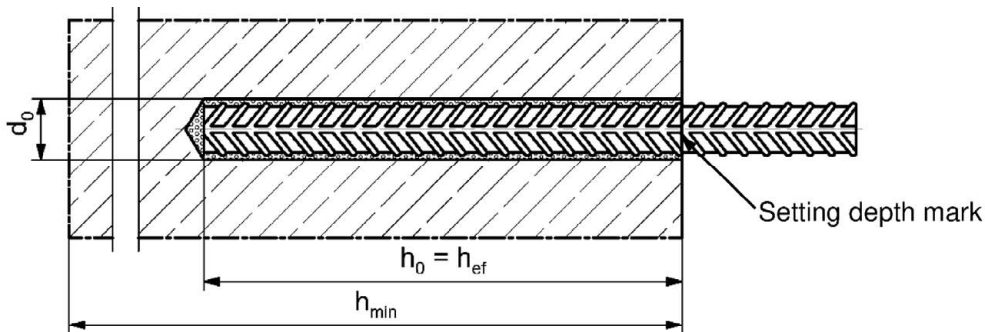

Figures not to scale

fischer injection system FIS V Plus

Intended use
Installation parameters reinforcing bars

Annex B 7

Appendix 15 / 35

Table B8.1: Installation parameters for **fischer rebar anchor FRA** ¹⁾

Rebar anchor FRA		Thread	M12 ²⁾	M16	M20	M24
Nominal diameter of the bar	ϕ	[mm]	12	16	20	25
Width across flats	SW		19	24	30	36
Nominal drill hole diameter	d_0		14	16	20	30
Drill hole depth	h_0		$h_{ef} + l_e$			
Effective embedment depth	$h_{ef,min}$		70	80	90	96
	$h_{ef,max}$		140	220	300	380
Distance concrete surface to welded joint	l_e		100			
Minimum spacing and minimum edge distance	S_{min}		55	65	85	105
	C_{min}					
Diameter of clearance hole in the fixture	pre-positioned anchorage $\leq d_f$		14	18	22	26
	push through anchorage $\leq d_f$	18	22	26	32	
Minimum thickness of concrete member	h_{min}	$h_0 + 30$	$h_0 + 2d_0$			
Maximum installation torque	$\max T_{inst}$	[Nm]	40	60	120	150

¹⁾ minimum spacing and minimum edge distance see Annex B 5

²⁾ Both drill hole diameters can be used

fischer rebar anchor FRA

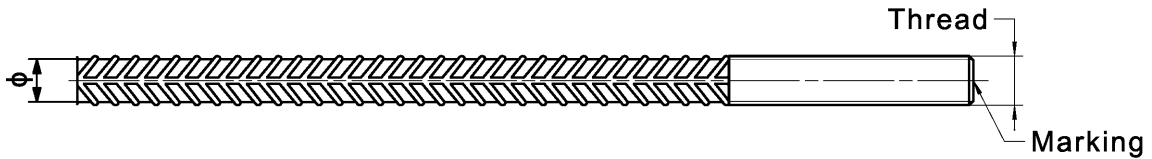

Marking frontal e.g:

- FRA (for stainless steel);
- FRA HCR (for high corrosion resistant steel)

Installation conditions:

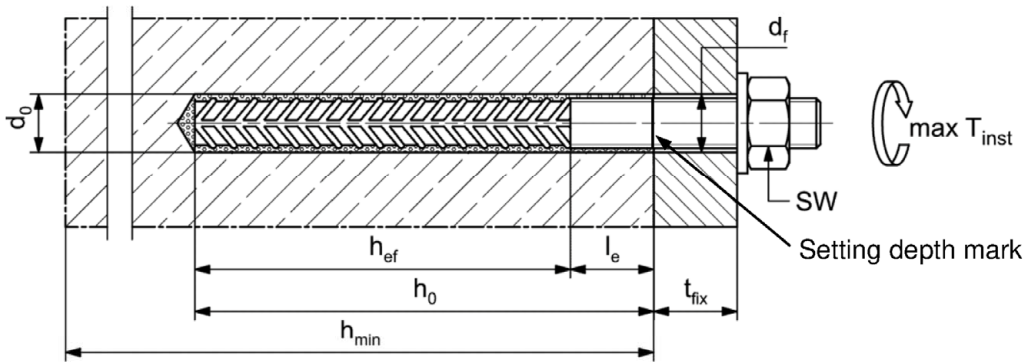

Figures not to scale

fischer injection system FIS V Plus

Intended use
Installation parameters rebar anchor FRA

Annex B 8

Appendix 16 / 35

Table B9.1: Parameters of the cleaning brush BS (steel brush with steel bristles)

The size of the cleaning brush refers to the drill hole diameter

Nominal drill hole diameter	d_0	[mm]	8	10	12	14	16	18	20	24	25	28	30	35
Steel brush diameter	d_b		9	11	14	16	20		25	26	27	30	40	

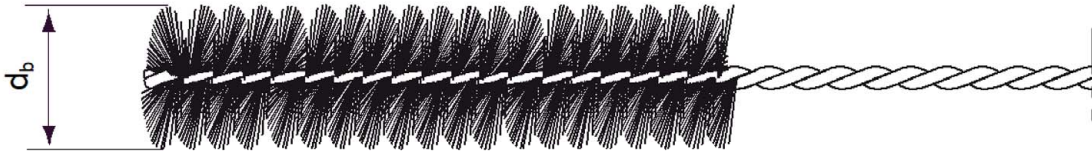

Table B9.2 Maximum processing time of the mortar and minimum curing time
(During the curing time of the mortar the concrete temperature may not fall below the listed minimum temperature)

Temperature at anchoring base [°C]	Maximum processing time t_{work}			Minimum curing time t_{cure} ¹⁾		
	FIS VW Plus High Speed	FIS V Plus	FIS VS Plus Low Speed	FIS VW Plus High Speed	FIS V Plus	FIS VS Plus Low Speed
-10 to -5 ²⁾	-	-	-	12 h	-	-
> -5 to 0 ²⁾	5 min	-	-	3 h	24 h	-
> 0 to 5 ²⁾	5 min	13 min	-	3 h	3 h	6 h
> 5 to 10	3 min	9 min	20 min	50 min	90 min	3 h
> 10 to 20	1 min	5 min	10 min	30 min	60 min	2 h
> 20 to 30	-	4 min	6 min	-	45 min	60 min
> 30 to 40	-	2 min	4 min	-	35 min	30 min

¹⁾ In wet concrete or water filled holes the curing times must be doubled

²⁾ Minimal cartridge temperature +5°C

fischer injection system FIS V Plus

Intended use

Cleaning brush (steel brush)
Processing time and curing time

Annex B 9

Appendix 17 / 35

Installation instructions part 1

Drilling and cleaning the hole (hammer drilling with standard drill bit)

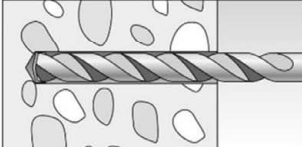
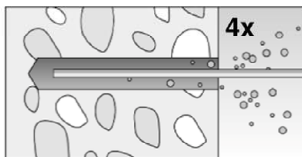
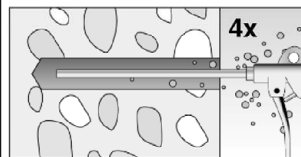
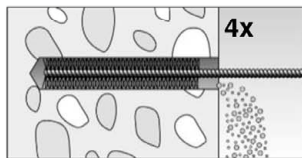
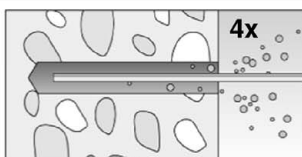
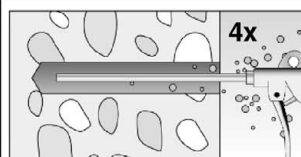
1		<p>Drill the hole. Nominal drill hole diameter d_0 and drill hole depth h_0 see tables B3.1, B6.1, B7.1, B8.1</p>	
2		<p>Clean the drill hole: For $h_{ef} \leq 12d$ and $d_0 < 18$ mm blow out the hole four times by hand</p>	 <p>For $h_{ef} > 12d$ and / or $d_0 \geq 18$ mm blow out the hole four times with oil-free compressed air ($p \geq 6$ bar)</p>
3		<p>Brush the drill hole four times. For drill hole diameter ≥ 30 mm use a power drill. For deep holes use an extension. Corresponding brushes see table B9.1</p>	
4		<p>Clean the drill hole: For $h_{ef} \leq 12d$ and $d_0 < 18$ mm blow out the hole four times by hand</p>	 <p>For $h_{ef} > 12d$ and / or $d_0 \geq 18$ mm blow out the hole four times with oil-free compressed air ($p \geq 6$ bar)</p>

Go to step 5

Drilling and cleaning the hole (hammer drilling with hollow drill bit)

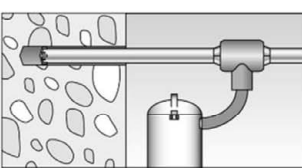
1		<p>Check a suitable hollow drill (see table B1.1) for correct operation of the dust extraction</p>	
2		<p>Use a suitable dust extraction system, e.g. fischer FVC 35 M or a comparable dust extraction system with equivalent performance data</p> <p>Drill the hole with hollow drill bit. The dust extraction system has to extract the drill dust nonstop during the drilling process and must be adjusted to maximum power. Nominal drill hole diameter d_0 and drill hole depth h_0 see tables B3.1, B6.1, B7.1, B8.1</p>	

Go to step 5

fischer injection system FIS V Plus





Intended use
Installation instructions part 1

Annex B 10

Appendix 18 / 35

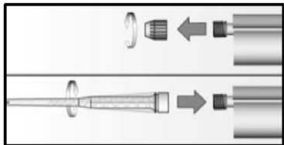
Installation instructions part 2

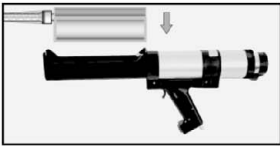
Preparing the cartridge

5		Remove the sealing cap Screw on the static mixer (the spiral in the static mixer must be clearly visible)
6		 Place the cartridge into the dispenser
7		 Extrude approximately 10 cm of material out until the resin is evenly grey in colour. Do not use mortar that is not uniformly grey

Go to step 8

Injection of the mortar

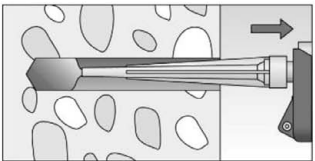
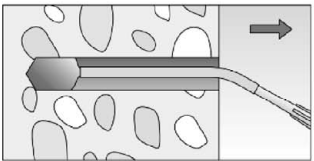
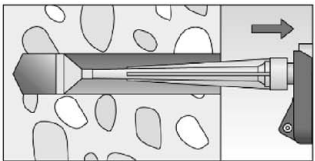
8	 <p>Fill approximately 2/3 of the drill hole with mortar. Always begin from the bottom of the hole and avoid bubbles</p>	 <p>For drill hole depth ≥ 150 mm use an extension tube</p>	 <p>For overhead installation, deep holes ($h_0 > 250$ mm) or drill hole diameter ($d_0 \geq 40$ mm) use an injection adapter</p>
---	---	--	---

Go to step 9

fischer injection system FIS V Plus



Intended use
Installation instructions part 2

Annex B 11

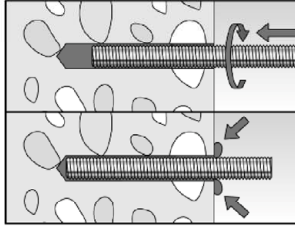
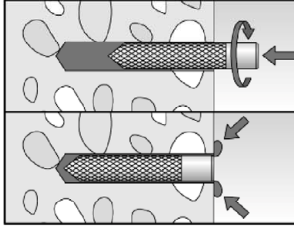
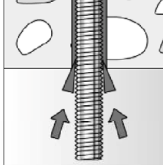
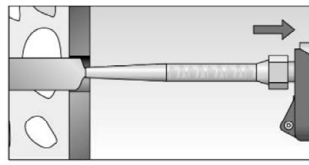

Appendix 19 / 35

Installation instructions part 3

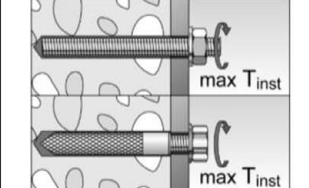
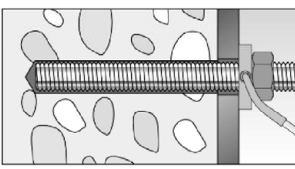
Installation of anchor rods or fischer internal threaded anchors RG MI

9			<p>Only use clean and oil-free metal parts. Mark the setting depth of the metal part. Push the anchor rod or fischer internal threaded RG MI anchor down to the bottom of the hole, turning it slightly while doing so. After inserting the metal parts, excess mortar must be emerged around the anchor element.</p>
		<p>For overhead installations support the metal part with wedges (e.g. fischer centering wedges) or fischer overhead clips.</p>	 <p>For push through installation fill the annular gap with mortar</p>
10		<p>Wait for the specified curing time t_{cure} see table B9.2</p>	<p>11</p>  <p>Mounting the fixture $\max T_{inst}$ see tables B3.1 and B6.1</p>
Option		<p>After the minimum curing time is reached, the gap between metal part and fixture (annular clearance) may be filled with mortar via the fischer filling disc. Compressive strength $\geq 50 \text{ N/mm}^2$ (e.g. fischer injection mortars FIS HB, FIS SB, FIS V, FIS V Plus, FIS EM Plus). ATTENTION: Using fischer filling disc reduces t_{fix} (usable length of the anchor)</p>	

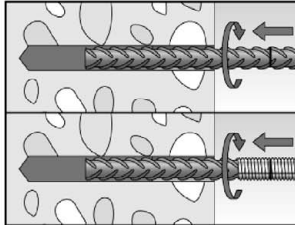
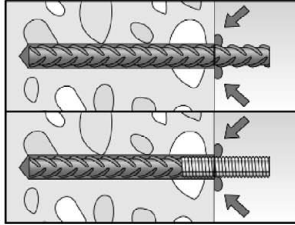
Installation reinforcing bars and fischer rebar anchor FRA

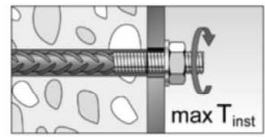
9		<p>Only use clean and oil-free reinforcing bars or fischer FRA. Mark the setting depth. Turn while using force to push the reinforcement bar or the fischer FRA into the filled hole up to the setting depth mark.</p>	
		<p>When the setting depth mark is reached, excess mortar must be emerged from the mouth of the drill hole.</p>	
10		<p>Wait for the specified curing time t_{cure} see table B9.2</p>	<p>11</p>  <p>Mounting the fixture $\max T_{inst}$ see table B8.1</p>

fischer injection system FIS V Plus

Intended use
Installation instructions part 3

Annex B 12

Appendix 20 / 35

Table C1.1: Characteristic values for steel failure under tension / shear load of fischer anchor rods and standard threaded rods

Anchor rod / standard threaded rod			M6	M8	M10	M12	M16	M20	M24	M27	M30		
Bearing capacity under tension load, steel failure ³⁾													
Characteristic resistance $N_{Rk,s}$	Steel zinc plated	Property class	4.8	[kN]	8	15(13)	23(21)	33	63	98	141	184	224
			5.8		10	19(17)	29(27)	43	79	123	177	230	281
			8.8		16	29(27)	47(43)	68	126	196	282	368	449
	Stainless steel R and high corrosion resistant steel HCR		50		10	19	29	43	79	123	177	230	281
			70		14	26	41	59	110	172	247	322	393
			80		16	30	47	68	126	196	282	368	449
Partial factors ¹⁾													
Partial factor $\gamma_{Ms,N}$	Steel zinc plated	Property class	4.8	[-]	1,50								
			5.8		1,50								
			8.8		1,50								
	Stainless steel R and high corrosion resistant steel HCR		50		2,86								
			70		1,50 ²⁾ / 1,87								
			80		1,60								
Bearing capacity under shear load, steel failure ³⁾													
without lever arm													
Characteristic resistance $V_{Rk,s}^0$	Steel zinc plated	Property class	4.8	[kN]	4	9(8)	14(13)	20	38	59	85	110	135
			5.8		6	11(10)	17(16)	25	47	74	106	138	168
			8.8		8	15(13)	23(21)	34	63	98	141	184	225
	Stainless steel R and high corrosion resistant steel HCR		50		5	9	15	21	39	61	89	115	141
			70		7	13	20	30	55	86	124	161	197
			80		8	15	23	34	63	98	141	184	225
Ductility factor		k ₇	[-]	1,0									
with lever arm													
Characteristic resistance $M_{Rk,s}^0$	Steel zinc plated	Property class	4.8	[Nm]	6	15(13)	30(27)	52	133	259	448	665	899
			5.8		7	19(16)	37(33)	65	166	324	560	833	1123
			8.8		12	30(26)	60(53)	105	266	519	896	1333	1797
	Stainless steel R and high corrosion resistant steel HCR		50		7	19	37	65	166	324	560	833	1123
			70		10	26	52	92	232	454	784	1167	1573
			80		12	30	60	105	266	519	896	1333	1797
Partial factors ¹⁾													
Partial factor $\gamma_{Ms,V}$	Steel zinc plated	Property class	4.8	[-]	1,25								
			5.8		1,25								
			8.8		1,25								
	Stainless steel R and high corrosion resistant steel HCR		50		2,38								
			70		1,25 ²⁾ / 1,56								
			80		1,33								
¹⁾ In absence of other national regulations ²⁾ Only admissible for high corrosion resist. steel HCR, with $f_{yk} / f_{uk} \geq 0,8$ and $A_5 > 12 \%$ (e.g. fischer anchor rods) ³⁾ Values in brackets are valid for undersized threaded rods with smaller stress area A_s for hot dip galvanised standard threaded rods according to EN ISO 10684:2004+AC:2009													

fischer injection system FIS V Plus

Performances

Characteristic values for steel failure under tension / shear load of fischer anchor rods and standard threaded rods

Annex C 1

Appendix 21 / 35

Table C2.1: Characteristic values for steel failure under tension / shear load of fischer internal threaded anchors RG MI

fischer internal threaded anchors RG MI			M8	M10	M12	M16	M20	
Bearing capacity under tension load, steel failure								
Charact. resistance with screw	$N_{Rk,s}$	Property class 5.8	[kN]	19	29	43	79	123
		8.8		29	47	68	108	179
		Property class 70 R		26	41	59	110	172
		HCR		26	41	59	110	172
Partial factors¹⁾								
Partial factors	$\gamma_{Ms,N}$	Property class 5.8	[-]	1,50				
		8.8		1,50				
		Property class 70 R		1,87				
		HCR		1,87				
Bearing capacity under shear load, steel failure								
Without lever arm								
Charact. resistance with screw	$V^{0}_{Rk,s}$	Property class 5.8	[kN]	9,2	14,5	21,1	39,2	62,0
		8.8		14,6	23,2	33,7	54,0	90,0
		Property class 70 R		12,8	20,3	29,5	54,8	86,0
		HCR		12,8	20,3	29,5	54,8	86,0
Ductility factor		k_7	[-]	1,0				
With lever arm								
Charact. resistance with screw	$M^0_{Rk,s}$	Property class 5.8	[Nm]	20	39	68	173	337
		8.8		30	60	105	266	519
		Property class 70 R		26	52	92	232	454
		HCR		26	52	92	232	454
Partial factors¹⁾								
Partial factors	$\gamma_{Ms,V}$	Property class 5.8	[-]	1,25				
		8.8		1,25				
		Property class 70 R		1,56				
		HCR		1,56				

¹⁾ In absence of other national regulations

fischer injection system FIS V Plus

Performances

Characteristic values for steel failure under tension / shear load of fischer internal threaded anchor RG MI

Table C3.1: Characteristic values for steel failure under tension / shear load of reinforcing bars

Nominal diameter of the bar	ϕ	8	10	12	14	16	20	25	28
Bearing capacity under tension load, steel failure									
Characteristic resistance	$N_{Rk,s}$	[kN]	$A_s \cdot f_{uk}^{1)}$						
Bearing capacity under shear load, steel failure									
Without lever arm									
Characteristic resistance	$V^0_{Rk,s}$	[kN]	$0,5 \cdot A_s \cdot f_{uk}^{1)}$						
Ductility factor	k_7	[-]	1,0						
With lever arm									
Characteristic resistance	$M^0_{Rk,s}$	[Nm]	$1,2 \cdot W_{el} \cdot f_{uk}^{1)}$						

¹⁾ f_{uk} or f_{yk} respectively must be taken from the specifications of the reinforcing bar

Table C3.2: Characteristic values for steel failure under tension / shear load of fischer rebar anchors FRA

fischer rebar anchor FRA		M12	M16	M20	M24	
Bearing capacity under tension load, steel failure						
Characteristic resistance	$N_{Rk,s}$	[kN]	63	111	173	270
Partial factor¹⁾						
Partial factor	$\gamma_{Ms,N}$	[-]	1,4			
Bearing capacity under shear load, steel failure						
Without lever arm						
Characteristic resistance	$V^0_{Rk,s}$	[kN]	30	55	86	124
Ductility factor	k_7	[-]	1,0			
With lever arm						
Characteristic resistance	$M^0_{Rk,s}$	[Nm]	92	233	454	785
Partial factor¹⁾						
Partial factor	$\gamma_{Ms,V}$	[-]	1,56			

¹⁾ In absence of other national regulations

fischer injection system FIS V Plus

Performances

Characteristic values for steel failure under tension / shear load of reinforcing bars and fischer rebar anchors FRA

Annex C 3

Appendix 23 / 35

Table C4.1: Characteristic values for concrete failure under tension / shear load												
Size			All sizes									
Tension load												
Installation factor		γ_{inst}	[-]		See annex C 5 to C 12 and C 17 to C18							
Factors for the compressive strength of concrete > C20/25												
Increasing factor for τ_{RK}	C25/30		Ψ_c	[-]	1,05							
	C30/37				1,10							
	C35/45				1,15							
	C40/50				1,19							
	C45/55				1,22							
	C50/60				1,26							
Splitting failure												
Edge distance	$h / h_{ef} \geq 2,0$		$C_{cr,sp}$	[mm]	1,0 h_{ef}							
	$2,0 > h / h_{ef} > 1,3$				4,6 h_{ef} - 1,8 h							
	$h / h_{ef} \leq 1,3$				2,26 h_{ef}							
Spacing		$S_{cr,sp}$	2 $C_{cr,sp}$									
Concrete failure												
Uncracked concrete		$k_{Ucr,N}$	[-]	11,0								
Cracked concrete		$k_{Cr,N}$		7,7								
Edge distance		$C_{cr,N}$	[mm]	1,5 h_{ef}								
Spacing		$S_{cr,N}$		2 $C_{cr,N}$								
Factors for sustained tension load												
Temperature range			[-]		50 °C / 80 °C			72 °C / 120 °C				
Factor		Ψ_{sus}^0	[-]		0,76			0,78				
Shear load												
Installation factor		γ_{inst}	[-]		1,0							
Concrete pry-out failure												
Factor for pry-out failure		k_8	[-]		2,0							
Concrete edge failure												
Effective length of fastener in shear loading		l_f	[mm]	for $d_{nom} \leq 24$ mm: min (h_{ef} ; 12 d_{nom}) for $d_{nom} > 24$ mm: min (h_{ef} ; 8 d_{nom} ; 300 mm)								
Calculation diameters												
Size			M6	M8	M10	M12	M16	M20	M24	M27	M30	
fischer anchor rods and standard threaded rods		d_{nom}	[mm]	6	8	10	12	16	20	24	27	30
fischer internal threaded anchors RG MI		d_{nom}		-1)	12	16	18	22	28	-1)	-1)	-1)
fischer rebar anchor FRA		d_{nom}		-1)	-1)	-1)	12	16	20	25	-1)	-1)
Size (nominal diameter of the bar)		ϕ	8	10	12	14	16	20	25	28		
Reinforcing bar		d_{nom}	[mm]	8	10	12	14	16	20	25	28	
1) Size of anchor type not part of the assessment												
fischer injection system FIS V Plus									Annex C 4 Appendix 24 / 35			
Performances Characteristic values for concrete failure under tension / shear load												

Table C5.1: Characteristic values for combined pull-out and concrete failure for fischer anchor rods and standard threaded rods in hammer drilled holes; uncracked or cracked concrete; working life 50 years

Anchor rod / standard threaded rod		M6	M8	M10	M12	M16	M20	M24	M27	M30			
Combined pullout and concrete cone failure													
Calculation diameter	d	[mm]	6	8	10	12	16	20	24	27	30		
Uncracked concrete													
Characteristic bond resistance in uncracked concrete C20/25													
Hammer-drilling with standard drill bit or hollow drill bit (dry or wet concrete)													
Tem- perature range	I: 50 °C / 80 °C		$\tau_{Rk,ucr}$	[N/mm ²]	9,0	16,0	16,0	15,0	14,0	12,0	11,0	10,0	9,0
	II: 72 °C / 120 °C				6,5	15,0	14,0	13,0	12,0	11,0	9,0	8,0	8,0
Hammer-drilling with standard drill bit or hollow drill bit (water filled hole)													
Tem- perature range	I: 50 °C / 80 °C		$\tau_{Rk,ucr}$	[N/mm ²]	-1)	-1)	-1)	9,5	8,5	8,0	7,5	7,0	7,0
	II: 72 °C / 120 °C				-1)	-1)	-1)	7,5	7,0	6,5	6,0	6,0	6,0
Installation factors													
Dry or wet concrete	γ_{inst}	[-]	1,0										
Water filled hole	γ_{inst}	[-]	-1)	-1)	-1)	1,2							
Cracked concrete													
Characteristic bond resistance in cracked concrete C20/25													
Hammer-drilling with standard drill bit or hollow drill bit (dry or wet concrete)													
Tem- perature range	I: 50 °C / 80 °C		$\tau_{Rk,cr}$	[N/mm ²]	-1)	5,5	6,0	6,5	6,0	5,5	5,0	5,0	4,5
	II: 72 °C / 120 °C				-1)	4,5	5,0	6,0	5,5	5,0	4,5	4,0	4,0
Hammer-drilling with standard drill bit or hollow drill bit (water filled hole)													
Tem- perature range	I: 50 °C / 80 °C		$\tau_{Rk,cr}$	[N/mm ²]	-1)	-1)	-1)	5,0	5,0	4,5	4,0	3,5	3,5
	II: 72 °C / 120 °C				-1)	-1)	-1)	4,0	4,0	4,0	3,5	3,0	3,0
Installation factors													
Dry or wet concrete	γ_{inst}	[-]	1,0										
Water filled hole	γ_{inst}	[-]	-1)	-1)	-1)	1,2							

¹⁾ No performance assessed

fischer injection system FIS V Plus

Performances

Characteristic values for combined pull-out and concrete failure for fischer anchor rod and standard threaded rods; working life 50 years

Annex C 5

Appendix 25 / 35

Table C6.1: Characteristic values for combined pull-out and concrete failure for fischer anchor rods and standard threaded rods in hammer drilled holes; uncracked or cracked concrete; working life 100 years

Anchor rod / standard threaded rod		M6	M8	M10	M12	M16	M20	M24	M27	M30			
Combined pullout and concrete cone failure													
Calculation diameter	d	[mm]	6	8	10	12	16	20	24	27	30		
Uncracked concrete													
Characteristic bond resistance in uncracked concrete C20/25													
Hammer-drilling with standard drill bit or hollow drill bit (dry or wet concrete)													
Tem- perature range	I: 50 °C / 80 °C		$\tau_{Rk,100,ucr}$	[N/mm ²]	-1)	16,0	16,0	15,0	14,0	12,0	11,0	10,0	9,0
	II: 72 °C / 120 °C				-1)	15,0	14,0	13,0	12,0	11,0	9,0	8,0	8,0
Hammer-drilling with standard drill bit or hollow drill bit (water filled hole)													
Tem- perature range	I: 50 °C / 80 °C		$\tau_{Rk,100,ucr}$	[N/mm ²]	-1)	-1)	-1)	9,5	8,5	8,0	7,5	7,0	7,0
	II: 72 °C / 120 °C				-1)	-1)	-1)	7,5	7,0	6,5	6,0	6,0	6,0
Installation factors													
Dry or wet concrete		γ_{inst}	[-]	1,0									
Water filled hole		γ_{inst}	[-]	-1)	-1)	-1)	1,2						
Cracked concrete													
Characteristic bond resistance in cracked concrete C20/25													
Hammer-drilling with standard drill bit or hollow drill bit (dry or wet concrete)													
Tem- perature range	I: 50 °C / 80 °C		$\tau_{Rk,100,cr}$	[N/mm ²]	-1)	5,0	5,5	5,5	5,5	5,5	5,0	5,0	4,5
	II: 72 °C / 120 °C				-1)	4,5	5,0	5,0	5,0	5,0	4,0	4,0	4,0
Hammer-drilling with standard drill bit or hollow drill bit (water filled hole)													
Tem- perature range	I: 50 °C / 80 °C		$\tau_{Rk,100,cr}$	[N/mm ²]	-1)	-1)	-1)	4,5	4,5	4,5	4,0	3,5	3,5
	II: 72 °C / 120 °C				-1)	-1)	-1)	4,0	4,0	4,0	3,5	3,0	3,0
Installation factors													
Dry or wet concrete		γ_{inst}	[-]	1,0									
Water filled hole		γ_{inst}	[-]	-1)	-1)	-1)	1,2						

¹⁾ No performance assessed

fischer injection system FIS V Plus

Performances

Characteristic values for combined pull-out and concrete failure for fischer anchor rod and standard threaded rods; working life 100 years

Annex C 6

Appendix 26 / 35

Table C7.1: Characteristic values for combined pull-out and concrete failure for fischer internal threaded anchors RG MI in hammer drilled holes; uncracked concrete; working life 50 years

Internal threaded anchor RG MI			M8	M10	M12	M16	M20	
Combined pullout and concrete cone failure								
Calculation diameter	d	[mm]	12	16	18	22	28	
Uncracked concrete								
Characteristic bond resistance in uncracked concrete C20/25								
Hammer-drilling with standard drill bit or hollow drill bit (dry or wet concrete)								
Tem- perature range	I: 50 °C / 80 °C	$\tau_{Rk,ucr}$	[N/mm ²]	10,5	10,0	9,5	9,0	8,5
	II: 72 °C / 120 °C			9,0	8,0	8,0	7,5	7,0
Hammer-drilling with standard drill bit or hollow drill bit (water filled hole)								
Tem- perature range	I: 50 °C / 80 °C	$\tau_{Rk,ucr}$	[N/mm ²]	10,0	9,0	9,0	8,5	8,0
	II: 72 °C / 120 °C			7,5	6,5	6,5	6,0	6,0
Installation factors								
Dry or wet concrete	γ_{inst}	[-]				1,0		
Water filled hole						1,2		

fischer injection system FIS V Plus

Performances

Characteristic values for combined pull-out and concrete failure for fischer internal threaded anchors RG MI; working life 50 years

Annex C 7

Appendix 27 / 35

Table C8.1: Characteristic values for combined pull-out and concrete failure for reinforcing bars in hammer drilled holes; uncracked or cracked concrete; working life 50 years

Nominal diameter of the bar		ϕ	8	10	12	14	16	20	25	28		
Combined pullout and concrete cone failure												
Calculation diameter		d	[mm]	8	10	12	14	16	20	25	28	
Uncracked concrete												
Characteristic bond resistance in uncracked concrete C20/25												
Hammer-drilling with standard drill bit or hollow drill bit (dry or wet concrete)												
Temperature range	I: 50 °C / 80 °C		$\tau_{Rk,ucr}$	[N/mm ²]	11,0	11,0	11,0	10,0	10,0	9,5	9,0	8,5
	II: 72 °C / 120 °C				9,5	9,5	9,0	8,5	8,5	8,0	7,5	7,0
Installation factor												
Dry or wet concrete		γ_{inst}	[-]	1,0								
Cracked concrete												
Characteristic bond resistance in cracked concrete C20/25												
Hammer-drilling with standard drill bit or hollow drill bit (dry or wet concrete)												
Temperature range	I: 50 °C / 80 °C		$\tau_{Rk,ucr}$	[N/mm ²]	- ¹⁾	3,0	5,0	5,0	5,0	4,5	4,0	4,0
	II: 72 °C / 120 °C				- ¹⁾	3,0	4,5	4,5	4,5	4,0	3,5	3,5
Installation factor												
Dry or wet concrete		γ_{inst}	[-]	1,0								

¹⁾ No performance assessed

fischer injection system FIS V Plus

Performances

Characteristic values for combined pull-out and concrete failure for reinforcing bars; working life 50 years

Annex C 8

Appendix 28 / 35

Table C9.1: Characteristic values for combined pull-out and concrete failure for fischer rebar anchors FRA in hammer drilled holes; uncracked or cracked concrete; working life 50 years

fischer rebar anchor FRA		M12	M16	M20	M24	
Combined pullout and concrete cone failure						
Calculation diameter	d [mm]	12	16	20	25	
Uncracked concrete						
Characteristic bond resistance in uncracked concrete C20/25						
Hammer-drilling with standard drill bit or hollow drill bit (dry or wet concrete)						
Temperature range	I: 50 °C / 80 °C	$\tau_{Rk,ucr}$ [N/mm ²]	11,0	10,0	9,5	9,5
	II: 72 °C / 120 °C		9,0	8,5	8,0	7,5
Installation factors						
Dry or wet concrete	γ_{inst}	[-]	1,0			
Cracked concrete						
Characteristic bond resistance in cracked concrete C20/25						
Hammer-drilling with standard drill bit or hollow drill bit (dry or wet concrete)						
Temperature range	I: 50 °C / 80 °C	$\tau_{Rk,cr}$ [N/mm ²]	5,0	5,0	4,5	4,0
	II: 72 °C / 120 °C		4,5	4,5	4,0	3,5
Installation factors						
Dry or wet concrete	γ_{inst}	[-]	1,0			

fischer injection system FIS V Plus

Performances

Characteristic values for combined pull-out and concrete failure for fischer rebar anchors FRA; working life 50 years

Annex C 9

Table C10.1: Displacements for anchor rods

Anchor rod		M6	M8	M10	M12	M16	M20	M24	M27	M30
Displacement-Factors for tension load¹⁾										
Uncracked concrete; Temperature range I, II										
δ_{N0} -Factor	[mm/(N/mm ²)]	0,09	0,09	0,09	0,10	0,10	0,10	0,10	0,11	0,12
$\delta_{N\infty}$ -Factor		0,10	0,10	0,10	0,12	0,12	0,12	0,13	0,13	0,14
Cracked concrete; Temperature range I, II										
δ_{N0} -Factor	[mm/(N/mm ²)]	- ³⁾	0,12	0,12	0,12	0,13	0,13	0,13	0,14	0,15
$\delta_{N\infty}$ -Factor		- ³⁾	0,25	0,27	0,30	0,30	0,30	0,35	0,35	0,40
Displacement-Factors for shear load²⁾										
Uncracked or cracked concrete; Temperature range I, II										
δ_{V0} -Factor	[mm/kN]	0,11	0,11	0,11	0,10	0,10	0,09	0,09	0,08	0,07
$\delta_{V\infty}$ -Factor		0,12	0,12	0,12	0,11	0,11	0,10	0,10	0,09	0,09
1) Calculation of effective displacement: $\delta_{N0} = \delta_{N0\text{-Factor}} \cdot \tau_{Ed}$ $\delta_{N\infty} = \delta_{N\infty\text{-Factor}} \cdot \tau_{Ed}$ (τ_{Ed} : Design value of the applied tensile stress)					2) Calculation of effective displacement: $\delta_{V0} = \delta_{V0\text{-Factor}} \cdot V_{Ed}$ $\delta_{V\infty} = \delta_{V\infty\text{-Factor}} \cdot V_{Ed}$ (V_{Ed} : Design value of the applied shear force)					
3) No performance assessed										

Table C10.2: Displacements for fischer internal threaded anchors RG MI

Internal threaded anchor RG MI		M8	M10	M12	M16	M20
Displacement-Factors for tension load¹⁾						
Uncracked concrete; Temperature range I, II						
δ_{N0} -Factor	[mm/(N/mm ²)]	0,10	0,11	0,12	0,13	0,14
$\delta_{N\infty}$ -Factor		0,13	0,14	0,15	0,16	0,18
Displacement-Factors for shear load²⁾						
Uncracked concrete; Temperature range I, II						
δ_{V0} -Factor	[mm/kN]	0,12	0,12	0,12	0,12	0,12
$\delta_{V\infty}$ -Factor		0,14	0,14	0,14	0,14	0,14
1) Calculation of effective displacement: $\delta_{N0} = \delta_{N0\text{-Factor}} \cdot \tau_{Ed}$ $\delta_{N\infty} = \delta_{N\infty\text{-Factor}} \cdot \tau_{Ed}$ (τ_{Ed} : Design value of the applied tensile stress)			2) Calculation of effective displacement: $\delta_{V0} = \delta_{V0\text{-Factor}} \cdot V_{Ed}$ $\delta_{V\infty} = \delta_{V\infty\text{-Factor}} \cdot V_{Ed}$ (V_{Ed} : Design value of the applied shear force)			

fischer injection system FIS V Plus

Performances

Displacements for anchor rods and fischer internal threaded anchors RG MI

Annex C 10

Table C11.1: Displacements for reinforcing bars

Nominal diameter of the bar ϕ	8	10	12	14	16	20	25	28	
Displacement-Factors for tension load¹⁾									
Uncracked concrete; Temperature range I, II									
δ_{N0} -Factor	[mm/(N/mm ²)]	0,09	0,09	0,10	0,10	0,10	0,10	0,10	0,11
$\delta_{N\infty}$ -Factor		0,10	0,10	0,12	0,12	0,12	0,12	0,13	0,13
Cracked concrete; Temperature range I, II									
δ_{N0} -Factor	[mm/(N/mm ²)]	- ³⁾	0,12	0,13	0,13	0,13	0,13	0,13	0,14
$\delta_{N\infty}$ -Factor		- ³⁾	0,27	0,30	0,30	0,30	0,30	0,35	0,37
Displacement-Factors for shear load²⁾									
Uncracked or cracked concrete; Temperature range I, II									
δ_{V0} -Factor	[mm/kN]	0,11	0,11	0,10	0,10	0,10	0,09	0,09	0,08
$\delta_{V\infty}$ -Factor		0,12	0,12	0,11	0,11	0,11	0,10	0,10	0,09
¹⁾ Calculation of effective displacement: $\delta_{N0} = \delta_{N0}\text{-Factor} \cdot \tau_{Ed}$ $\delta_{N\infty} = \delta_{N\infty}\text{-Factor} \cdot \tau_{Ed}$ (τ_{Ed} : Design value of the applied tensile stress)					²⁾ Calculation of effective displacement: $\delta_{V0} = \delta_{V0}\text{-Factor} \cdot V_{Ed}$ $\delta_{V\infty} = \delta_{V\infty}\text{-Factor} \cdot V_{Ed}$ (V_{Ed} : Design value of the applied shear force)				
³⁾ No performance assessed									

Table C11.2: Displacements for fischer rebar anchors FRA

fischer rebar anchor FRA	M12	M16	M20	M24	
Displacement-Factors for tension load¹⁾					
Uncracked concrete; Temperature range I, II					
δ_{N0} -Factor	[mm/(N/mm ²)]	0,10	0,10	0,10	0,10
$\delta_{N\infty}$ -Factor		0,12	0,12	0,12	0,13
Cracked concrete; Temperature range I, II					
δ_{N0} -Factor	[mm/(N/mm ²)]	0,12	0,13	0,13	0,13
$\delta_{N\infty}$ -Factor		0,30	0,30	0,30	0,35
Displacement-Factors for shear load²⁾					
Uncracked or cracked concrete; Temperature range I, II					
δ_{V0} -Factor	[mm/kN]	0,10	0,10	0,09	0,09
$\delta_{V\infty}$ -Factor		0,11	0,11	0,10	0,10
¹⁾ Calculation of effective displacement: $\delta_{N0} = \delta_{N0}\text{-Factor} \cdot \tau_{Ed}$ $\delta_{N\infty} = \delta_{N\infty}\text{-Factor} \cdot \tau_{Ed}$ (τ_{Ed} : Design value of the applied tensile stress)			²⁾ Calculation of effective displacement: $\delta_{V0} = \delta_{V0}\text{-Factor} \cdot V_{Ed}$ $\delta_{V\infty} = \delta_{V\infty}\text{-Factor} \cdot V_{Ed}$ (V_{Ed} : Design value of the applied shear force)		

fischer injection system FIS V Plus

Performances
Displacements for reinforcing bars and fischer rebar anchors FRA

Annex C 11

Appendix 31 / 35

Table C12.1: Characteristic values for steel failure under tension / shear load of fischer anchor rods and standard threaded rods under seismic action performance category C1 or C2

Anchor rod / standard threaded rod		M10	M12	M16	M20	M24	M27	M30			
Bearing capacity under tension load, steel failure¹⁾											
fischer anchor rods and standard threaded rods, performance category C1²⁾											
Characteristic resistance $N_{Rk,s,C1}$	Steel zinc plated	Property class	5.8	[kN]	29(27)	43	79	123	177	230	281
			8.8		47(43)	68	126	196	282	368	449
	Stainless steel R and high corrosion resistant steel HCR	50	29		43	79	123	177	230	281	
		70	41		59	110	172	247	322	393	
		80	47		68	126	196	282	368	449	
fischer anchor rods, performance category C2²⁾											
Characteristic resistance $N_{Rk,s,C2}$	Steel zinc plated	Property class	5.8	[kN]	-4)	39	72	108	-4)	-4)	-4)
			8.8		-4)	61	116	173	-4)	-4)	-4)
	Stainless steel R and high corrosion resistant steel HCR	50	-4)		39	72	108	-4)	-4)	-4)	
		70	-4)		53	101	152	-4)	-4)	-4)	
		80	-4)		61	116	173	-4)	-4)	-4)	
Bearing capacity under shear load, steel failure without lever arm¹⁾											
fischer anchor rods, performance category C1²⁾											
Characteristic resistance $V_{Rk,s,C1}$	Steel zinc plated	Property class	5.8	[kN]	17(16)	25	47	74	106	138	168
			8.8		23(21)	34	63	98	141	184	225
	Stainless steel R and high corrosion resistant steel HCR	50	15		21	39	61	89	115	141	
		70	20		30	55	86	124	161	197	
		80	23		34	63	98	141	184	225	
Standard threaded rods, performance category C1²⁾											
Characteristic resistance $V_{Rk,s,C1}$	Steel zinc plated	Property class	5.8	[kN]	12(11)	17	33	52	74	97	118
			8.8		16(14)	24	44	69	99	129	158
	Stainless steel R and high corrosion resistant steel HCR	50	11		15	27	43	62	81	99	
		70	14		21	39	60	87	113	138	
		80	16		24	44	69	99	129	158	
fischer anchor rods, performance category C2											
Characteristic resistance $V_{Rk,s,C2}$	Steel zinc plated	Property class	5.8	[kN]	-4)	14	27	43	-4)	-4)	-4)
			8.8		-4)	22	44	69	-4)	-4)	-4)
	Stainless steel R and high corrosion resistant steel HCR	50	-4)		14	27	43	-4)	-4)	-4)	
		70	-4)		20	39	60	-4)	-4)	-4)	
		80	-4)		22	44	69	-4)	-4)	-4)	
Factor for the annular gap	α_{gap}	[-]	0,5 (1,0) ³⁾								

1) Partial factors for performance category C1 or C2 see table C13.1; for fischer anchor rods FIS A / RGM the factor for steel ductility is 1,0

2) Values in brackets are valid for undersized threaded rods with smaller stress area A_s and for hot dip galvanised standard threaded rods according to EN ISO 10684:2004+AC:2009.

3) Values in brackets are valid for filled annular gaps between the anchor rod and the through-hole in the attachment. It is necessary to use the fischer filling disc according to Annex A 5

4) No performance assessed

fischer injection system FIS V Plus

Performances

Characteristic values for steel failure under tension / shear load for fischer anchor rods and standard threaded rods under seismic action (performance category C1 / C2)

Annex C 12

Appendix 32 / 35

Table C13.1: Partial factors for fischer anchor rods, standard threaded rods under seismic action performance category C1 or C2

Anchor rod / standard threaded rod			M10	M12	M16	M20	M24	M27	M30
Tension load, steel failure¹⁾									
Partial factor $\gamma_{Ms,N}$	Steel zinc plated	Property class	5.8	[-]	1,50				
			8.8		1,50				
	Stainless steel R and high corrosion resistant steel HCR		50		2,86				
			70		1,50 ²⁾ / 1,87				
			80		1,60				
Shear load, steel failure¹⁾									
Partial factor $\gamma_{Ms,V}$	Steel zinc plated	Property class	5.8	[-]	1,25				
			8.8		1,25				
	Stainless steel R and high corrosion resistant steel HCR		50		2,38				
			70		1,25 ²⁾ / 1,56				
			80		1,33				

¹⁾ In absence of other national regulations

²⁾ Only admissible for high corrosion resistant steel HCR, with $f_{yk} / f_{uk} \geq 0,8$ and $A_5 > 12\%$ (e.g. fischer anchor rods)

fischer injection system FIS V Plus

Performances

Partial factors under seismic action (performance category C1 and C2) for fischer anchor rods and standard threaded rods

Annex C 13

Appendix 33 / 35

Table C14.1: Characteristic values for combined pull-out and concrete failure for **fischer anchor rods** and **standard threaded rods** in hammer drilled holes under seismic action performance category **C1, working life 50 and 100 years**

Anchor rod / standard threaded rod		M10	M12	M16	M20	M24	M27	M30	
Characteristic bond resistance, combined pullout and concrete cone failure									
Hammer-drilling with standard drill bit or hollow drill bit (dry or wet concrete)									
Temperature range	I: 50 °C / 80 °C	$\tau_{Rk,C1}$ [N/mm ²]	4,5	5,5	5,5	5,5	4,5	4,0	4,0
	II: 72 °C / 120 °C		4,0	4,5	4,5	4,5	4,0	3,5	3,5
Hammer-drilling with standard drill bit or hollow drill bit (water filled hole)									
Temperature range	I: 50 °C / 80 °C	$\tau_{Rk,C1}$ [N/mm ²]	- ¹⁾	5,0	5,0	4,5	4,0	3,5	3,5
	II: 72 °C / 120 °C		- ¹⁾	4,0	4,0	4,0	3,5	3,0	3,0
Installation factors									
Dry or wet concrete	γ_{inst}	[-]	1,0						
Water filled hole			- ¹⁾	1,2					

¹⁾ No performance assessed

fischer injection system FIS V Plus

Performances

Characteristic values under seismic action (performance category C1) for fischer anchor rods and standard threaded rods, working life 50 and 100 years

Annex C 14

Appendix 34 / 35

Table C15.1: Characteristic values for combined pull-out and concrete failure for fischer anchor rods in hammer drilled holes under seismic action performance category C2; working life 50 and 100 years

Anchor rod / standard threaded rod		M12	M16	M20	
Characteristic bond resistance, combined pullout and concrete cone failure					
Hammer-drilling with standard drill bit or hollow drill bit (dry or wet concrete)					
Temperature range	I: 50 °C / 80 °C	$\tau_{Rk,C2}$ [N/mm ²]	1,5	1,3	2,1
	II: 72 °C / 120 °C		1,3	1,2	1,9
Hammer-drilling with standard drill bit or hollow drill bit (water filled hole)					
Temperature range	I: 50 °C / 80 °C	$\tau_{Rk,C2}$ [N/mm ²]	1,3	1,1	1,8
	II: 72 °C / 120 °C		1,1	1,0	1,6
Displacement-Factors for tension load¹⁾					
$\delta_{N,C2}$ (DLS)-Factor	[mm/(N/mm ²)]	0,20	0,13	0,21	
$\delta_{N,C2}$ (ULS)-Factor		0,38	0,18	0,24	
Displacement-Factors for shear load²⁾					
$\delta_{V,C2}$ (DLS)-Factor	[mm/kN]	0,18	0,10	0,07	
$\delta_{V,C2}$ (ULS)-Factor		0,25	0,14	0,11	
¹⁾ Calculation of effective displacement: $\delta_{N,C2}$ (DLS) = $\delta_{N,C2}$ (DLS)-Factor · τ_{Ed} $\delta_{N,C2}$ (ULS) = $\delta_{N,C2}$ (ULS)-Factor · τ_{Ed} (τ_{Ed} : Design value of the applied tensile stress)		²⁾ Calculation of effective displacement: $\delta_{V,C2}$ (DLS) = $\delta_{V,C2}$ (DLS)-Factor · V_{Ed} $\delta_{V,C2}$ (ULS) = $\delta_{V,C2}$ (ULS)-Factor · V_{Ed} (V_{Ed} : Design value of the applied shear force)			
³⁾ No performance assessed					

fischer injection system FIS V Plus

Performances

Characteristic values under seismic action (performance category C2) for fischer anchor rods; working life 50 and 100 years

Annex C 15