

## PRESTANDEDEKLARATION

### DoP 0218

för fischer injektionssystem FIS EM Plus (Metallankare för användning i betong)

SV

- |   |   |
|---|---|
| 1. <u>Produkttypens unika identifikationskod:</u>                     | <b>DoP 0218</b>   |
| 2. <u>Avsedd användning/avsedda användningar:</u>                     | <b>Infästning i efterhand i sprucken och osprucken betong, Se bilaga, särskilt bilagor B1- B13.</b> |
| 3. <u>Tillverkare:</u>  | <b>fischerwerke GmbH &amp; Co. KG, Otto-Hahn-Straße 15, 79211 Denzlingen, Tyskland</b>              |
| 4. <u>Tillverkarens representant:</u>                                 | –   |
| 5. <u>System för bedömning och fortlöpande kontroll av prestanda:</u> | <b>1</b>  |
| 6. <u>Europeiskt bedömningsdokument:</u>                              | <b>EAD 330499-01-0601</b>   |
| Europeisk teknisk bedömning:  | <b>ETA-17/0979; 2020-06-17</b>  |
| Tekniskt bedömningsorgan:   | <b>DIBt- Deutsches Institut für Bautechnik</b>  |
| Anmält/ansömda organ:   | <b>2873 TU Darmstadt</b>  |

### 7. Angiven prestanda:

#### **Mekanisk hållfasthet och stabilitet (BWR 1)**

#### **Karakteristisk bärförmåga för spänning (för statisk och kvasi-statisk belastning):**

Stålets motståndskraft: Bilagor C1- C3  
Motstånd mot kombinerat fel vid utdragning och betongkon: Bilagor C5- C12  
Motstånd i betongkonen: Bilagor C4  
Kantavstånd för att slippa sprickor under last: Bilagor C4  
Kraftighet: Bilagor C4  
Maximal vridkraft vid installation: Bilagor B6- B8  
Minsta kant- och axelavstånd: Bilagor B4, B5

$E_s = 210\,000\text{ MPa}$   
 $\psi_{sus} = \text{NPD}$

#### **Karakteristisk bärförmåga för skjuvning (för statisk och kvasi-statisk belastning):**

Motstånd i stålet: Bilagor C1- C3  
Motstånd mot fläkning: Bilagor C4  
Motstånd mot skador i betong: Bilagor C4

#### **Förflyttningar under kort- och långvarig belastning:**

Förflyttningar under kort- och långvarig belastning: Bilagor C13, C14

#### **Karakteristiskt motstånd och Förskjutningar för seismiska prestandakategorier C1 och C2:**

Motstånd mot draglast, förskjutningar, kategori C1: Bilagor C15- C17  
Motstånd mot draglast, förskjutningar, kategori C2: Bilagor C15, C16, C18  
Motstånd mot tvärlast, förskjutningar, kategori C1: Bilagor C15- C17  
Motstånd mot tvärlast, förskjutningar, kategori C2: Bilagor C15, C16, C18  
Faktor cirkulärt håll: Bilagor C15

#### **Hygien, hälsa och miljö (BWR 3)**

Innehåll, frisläppning och / eller frisläppning av farliga ämnen: NPD

- |   |   |
|---|---|
| 8. <u>Lämplig teknisk dokumentation och/eller särskild teknisk dokumentation:</u> | – |
|---|---|

Prestandan för ovanstående produkt överensstämmer med den angivna prestandan. Denna prestandadeklaration har utfärdats i enlighet med förordning (EU) nr 305/2011 på eget ansvar av den tillverkare som anges ovan.

Undertecknad på tillverkarens vägnar av:



Dr.-Ing. Oliver Geibig, Verkställande direktör affärsenheter och teknik  
Tumlingen, 2021-04-05



Jürgen Grün, Verkställande direktör kemi och kvalitet

Denna DoP har förberetts på olika språk. I händelse av tvist om tolkningen ska den engelska versionen alltid råda.

Bilagan innehåller frivilliga och kompletterande information på engelska som överskrider (det specifika språkets) lagkrav.

## Specific Part

### 1 Technical description of the product

The "fischer injection system FIS EM Plus" is a bonded fastener consisting of a cartridge with injection mortar fischer FIS EM Plus and a steel element according to Annex A5.

The steel element is placed into a drilled hole filled with injection mortar and is anchored via the bond between metal part, injection mortar and concrete.

The product description is given in Annex A.

### 2 Specification of the intended use in accordance with the applicable European Assessment Document

The performances given in Section 3 are only valid if the anchor is used in compliance with the specifications and conditions given in Annex B.

The verifications and assessment methods on which this European Technical Assessment is based lead to the assumption of a working life of the anchor of at least 50 or 100 years. The indications given on the working life cannot be interpreted as a guarantee given by the producer, but are to be regarded only as a means for choosing the right products in relation to the expected economically reasonable working life of the works.

### 3 Performance of the product and references to the methods used for its assessment

#### 3.1 Mechanical resistance and stability (BWR 1)

Essential characteristic	Performance
Characteristic resistance to tension load (static and quasi-static loading)	See Annex B 3 to B 8, C 1 to C 12
Characteristic resistance to shear load (static and quasi-static loading)	See Annex C 1 to C 4
Displacements under short-term and long-term loading	See Annex C 13 and C 14
Characteristic resistance and displacements for seismic performance categories C1 and C2	See Annex C 15 to C 18

#### 3.2 Hygiene, health and the environment (BWR 3)

Essential characteristic	Performance
Content, emission and/or release of dangerous substances	No performance assessed

**4 Assessment and verification of constancy of performance (AVCP) system applied, with reference to its legal base**

In accordance with the European Assessment Document EAD 330499-01-0601 the applicable European legal act is: [96/582/EC].

The system to be applied is: 1

# Installation conditions part 1

## fischer anchor rod

### Pre-positioned installation

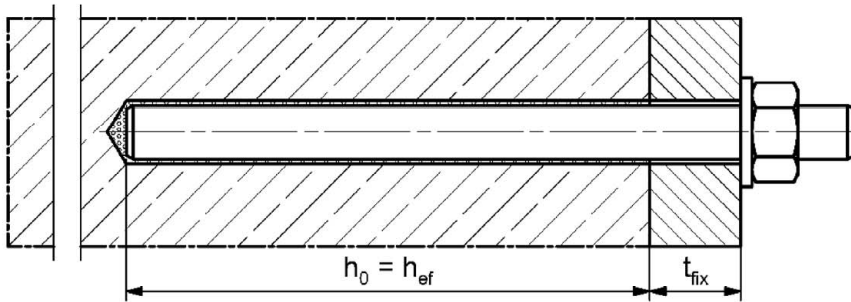

### Push through installation (annular gap filled with mortar)

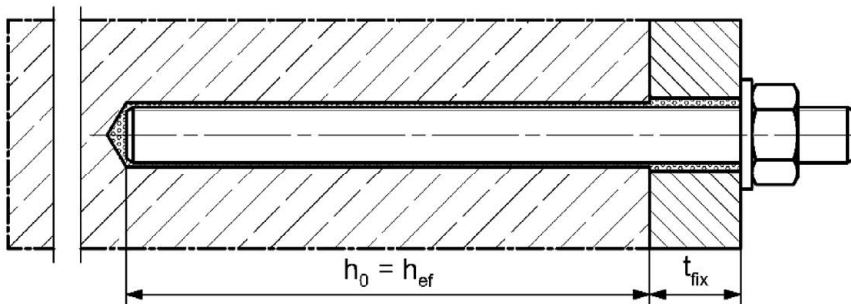

### Pre-positioned or push through installation with subsequently injected fischer filling disc (annular gap filled with mortar)

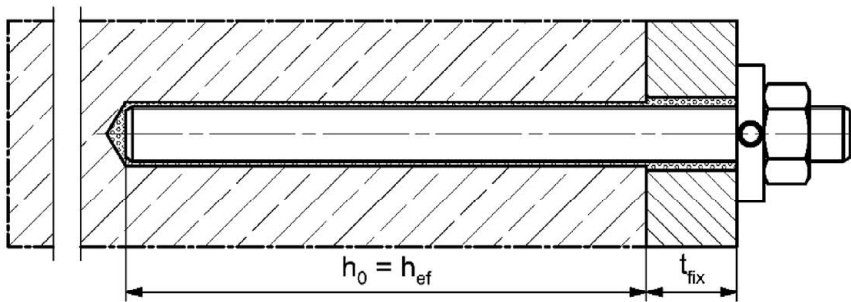

Figures not to scale

$h_0$  = drill hole depth

$h_{ef}$  = effective embedment depth

$t_{fix}$  = thickness of fixture

fischer injection system FIS EM Plus

**Product description**  
Installation conditions part 1

**Annex A 1**  
Appendix 3/ 39

## Installation conditions part 2

### fischer internal threaded anchor RG MI

#### Pre-positioned installation

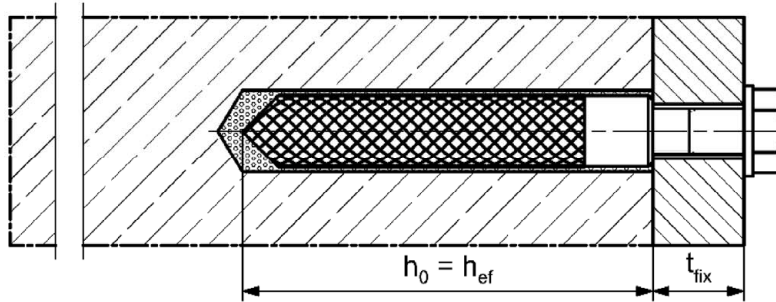

#### Pre-positioned installation with subsequently injected fischer filling disc (annular gap filled with mortar)

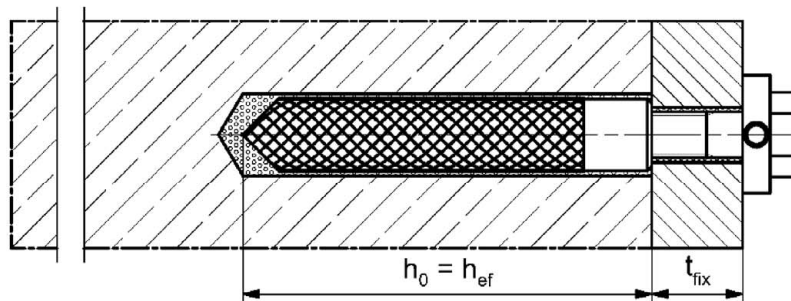

Figures not to scale

$h_0$  = drill hole depth

$h_{ef}$  = effective embedment depth

$t_{fix}$  = thickness of fixture

fischer injection system FIS EM Plus

**Product description**  
Installation conditions part 2

**Annex A 2**  
Appendix 4/ 39

# Installation conditions part 3

## Reinforcing bar

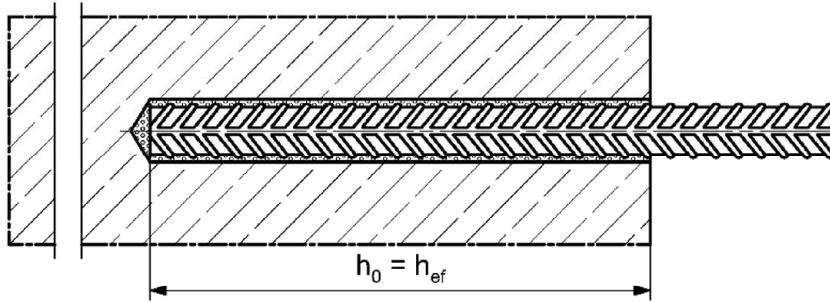

## fischer rebar anchor FRA

### Pre-positioned installation

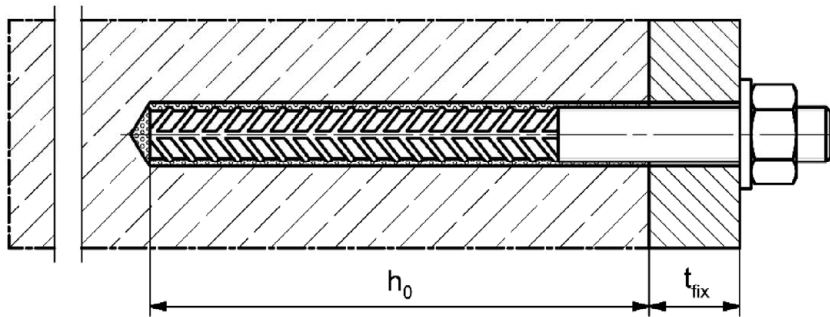

### Push through installation (annular gap filled with mortar)

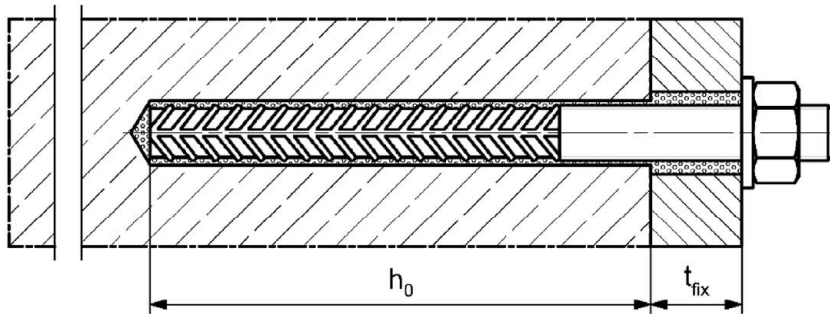

Figures not to scale

$h_0$  = drill hole depth

$h_{ef}$  = effective embedment depth

$t_{fix}$  = thickness of fixture

fischer injection system FIS EM Plus

**Product description**  
Installation conditions part 3

**Annex A 3**  
Appendix 5/ 39

## Overview system components part 1

Injection cartridge (shuttle cartridge) with sealing cap; Size: 390 ml, 585 ml, 1100 ml, 1500 ml

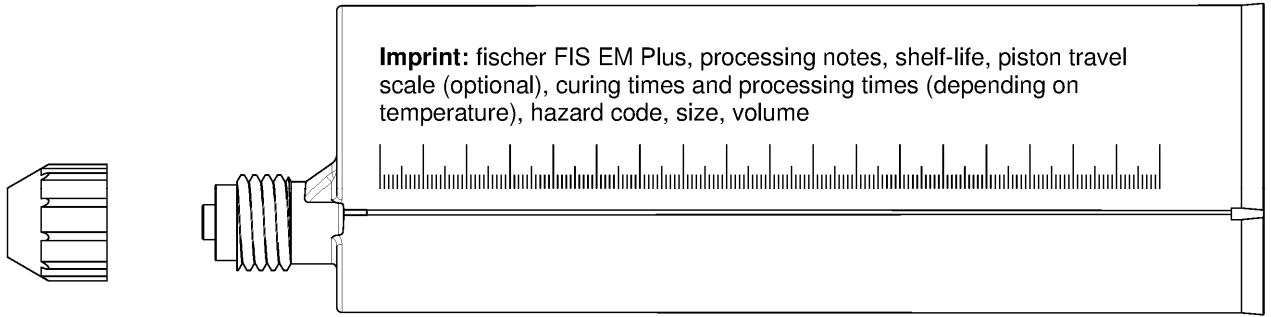

Static mixer FIS MR Plus or UMR

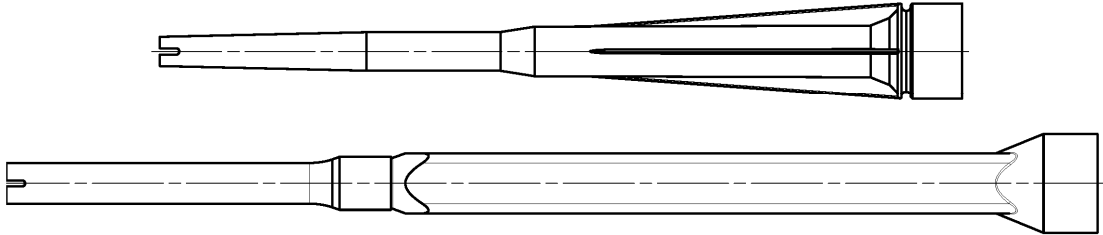

Injection adapter and Extension tube for static mixer

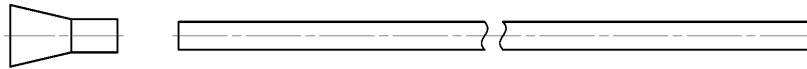

Cleaning brush BS / BSB



Blow-out pump ABP



Figures not to scale

fischer injection system FIS EM Plus

### Product description

Overview system components part 1;  
cartridges / static mixer / accessories

**Annex A 4**

Appendix 6/ 39

## Overview system components part 2

### fischer anchor rod

Size: M8, M10, M12, M14, M16, M20, M22, M24, M27, M30

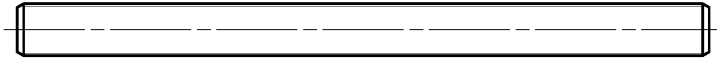

### fischer internal threaded anchor RG MI

Size: M8, M10, M12, M16, M20

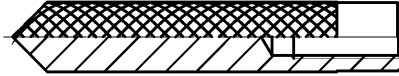

### Screw / threaded rod / washer / hexagon nut

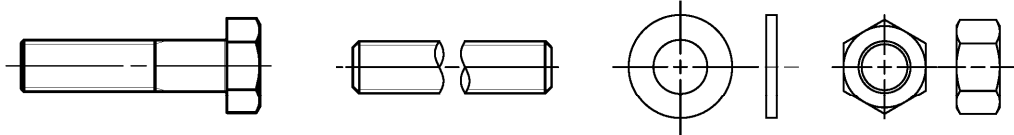

### fischer filling disc with injection adapter

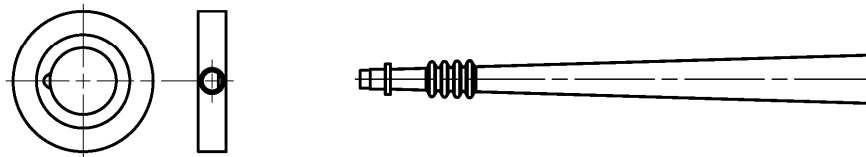

### Reinforcing bar

Nominal diameter:  $\phi 8$ ,  $\phi 10$ ,  $\phi 12$ ,  $\phi 14$ ,  $\phi 16$ ,  $\phi 18$ ,  $\phi 20$ ,  $\phi 22$ ,  $\phi 24$ ,  $\phi 25$ ,  $\phi 26$ ,  $\phi 28$ ,  $\phi 30$ ,  $\phi 32$ ,  $\phi 34$ ,  $\phi 36$ ,  $\phi 40$



### fischer rebar anchor FRA

Size: M12, M16, M20, M24



Figures not to scale

fischer injection system FIS EM Plus

#### Product description

Overview system components part 2;  
steel components

**Annex A 5**  
Appendix 7/ 39

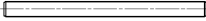







**Table A6.1: Materials**

Part	Designation	Material		
1	Injection cartridge	Mortar, hardener, filler		
	Steel grade	Steel	Stainless steel R	High corrosion resistant steel HCR
		zinc plated	acc. to EN 10088-1:2014 Corrosion resistance class CRC III acc. to EN 1993-1-4:2015	acc. to EN 10088-1:2014 Corrosion resistance class CRC V acc. to EN 1993-1-4:2015
2	Anchor rod	Property class 4.8, 5.8 or 8.8; EN ISO 898-1:2013 zinc plated $\geq 5 \mu\text{m}$ , ISO 4042:2018/Zn5/An(A2K) or hot dip galvanised $\geq 40 \mu\text{m}$ EN ISO 10684:2004 $f_{uk} \leq 1000 \text{ N/mm}^2$ $A_5 > 12\%$ fracture elongation	Property class 50, 70 or 80 EN ISO 3506-1:2009 1.4401; 1.4404; 1.4578; 1.4571; 1.4439; 1.4362; 1.4062, 1.4662, 1.4462; EN 10088-1:2014 $f_{uk} \leq 1000 \text{ N/mm}^2$ $A_5 > 12\%$ fracture elongation	Property class 50 or 80 EN ISO 3506-1:2009 or property class 70 with $f_{yk} = 560 \text{ N/mm}^2$ 1.4565; 1.4529; EN 10088-1:2014 $f_{uk} \leq 1000 \text{ N/mm}^2$ $A_5 > 12\%$ fracture elongation
		Fracture elongation $A_5 > 8 \%$ , for applications without requirements for seismic performance category C2		
3	Washer ISO 7089:2000	zinc plated $\geq 5 \mu\text{m}$ , ISO 4042:2018/Zn5/An(A2K) or hot dip galvanised $\geq 40 \mu\text{m}$ EN ISO 10684:2004	1.4401; 1.4404; 1.4578; 1.4571; 1.4439; 1.4362; EN 10088-1:2014	1.4565; 1.4529; EN 10088-1:2014
4	Hexagon nut	Property class 4, 5 or 8; EN ISO 898-2:2012 zinc plated $\geq 5 \mu\text{m}$ , ISO 4042:2018/Zn5/An(A2K) or hot dip galvanised $\geq 40 \mu\text{m}$ EN ISO 10684:2004	Property class 50, 70 or 80 EN ISO 3506-1:2009 1.4401; 1.4404; 1.4578; 1.4571; 1.4439; 1.4362; EN 10088-1:2014	Property class 50, 70 or 80 EN ISO 3506-1:2009 1.4565; 1.4529 EN 10088-1:2014
5	fischer internal threaded anchor RG MI	Property class 5.8 ISO 898-1:2013 zinc plated $\geq 5 \mu\text{m}$ , ISO 4042:2018/Zn5/An(A2K)	Property class 70 EN ISO 3506-1:2009 1.4401; 1.4404; 1.4578; 1.4571; 1.4439; 1.4362; EN 10088-1:2014	Property class 70 EN ISO 3506-1:2009 1.4565; 1.4529; EN 10088-1:2014
6	Commercial standard screw or threaded rod for fischer internal threaded anchor RG MI	Property class 5.8 or 8.8; EN ISO 898-1:2013 zinc plated $\geq 5 \mu\text{m}$ , ISO 4042:2018/Zn5/An(A2K) $A_5 > 8 \%$ fracture elongation	Property class 70 EN ISO 3506-1:2009 1.4401; 1.4404; 1.4578; 1.4571; 1.4439; 1.4362; EN 10088-1:2014 $A_5 > 8 \%$ fracture elongation	Property class 70 EN ISO 3506-1:2009 1.4565; 1.4529; EN 10088-1:2014 $A_5 > 8 \%$ fracture elongation
7	fischer filling disc similar to DIN 6319-G	zinc plated $\geq 5 \mu\text{m}$ , ISO 4042:2018/Zn5/An(A2K) or hot dip galvanised $\geq 40 \mu\text{m}$ EN ISO 10684:2004	1.4401; 1.4404; 1.4578; 1.4571; 1.4439; 1.4362; EN 10088-1:2014	1.4565; 1.4529; EN 10088-1:2014
8	Reinforcing bar EN 1992-1-1:2004 and AC:2010, Annex C	Bars and de-coiled rods, class B or C with $f_{yk}$ and $k$ according to NDP or NCL according to EN 1992-1-1/NA $f_{uk} = f_{tk} = k \cdot f_{yk}$		
9	fischer rebar anchor FRA	Rebar part: Bars and de-coiled rods class B or C with $f_{yk}$ and $k$ according to NDP or NCL of EN 1992-1-1:2004+AC:2010 $f_{uk} = f_{tk} = k \cdot f_{yk}$	Threaded part: Property class 70 or 80 EN ISO 3506-1:2009 1.4401, 1.4404, 1.4571, 1.4578, 1.4439, 1.4362, 1.4062 acc. to EN 10088-1:2014 Corrosion resistance class CRC III acc. to EN 1993-1-4:2015 1.4565; 1.4529 acc. to EN 10088-1:2014 Corrosion resistance class CRC V acc. to EN 1993-1-4:2015	
fischer injection system FIS EM Plus				<b>Annex A 6</b> Appendix 8/ 39
Product description Materials				

# Specifications of intended use (part 1)

**Table B1.1:** Overview use and performance categories

Anchorages subject to		FIS EM Plus with ...							
		Anchor rod 	fischer internal threaded anchor RG MI 	Reinforcing bar 	fischer rebar anchor FRA 				
Hammer drilling with standard drill bit 		all sizes							
Hammer drilling with hollow drill bit (fischer "FHD", Heller "Duster Expert"; Bosch „Speed Clean“; Hilti "TE-CD, TE-YD", DreBo „D-Plus“, DreBo „D-Max“) 		Nominal drill bit diameter ( $d_0$ ) 12 mm to 35 mm							
Diamond drilling 		all sizes							
Static and quasi static load, in	uncracked concrete	all sizes	Tables: C1.1 C4.1 C5.1 C6.1 C13.1	all sizes	Tables: C2.1 C4.1 C7.1 C8.1 C13.2	all sizes	Tables: C3.1 C4.1 C9.1 C10.1 C14.1	all sizes	Tables: C3.2 C4.1 C11.1 C12.1 C14.2
	cracked concrete								
Seismic performance category (only hammer drilling with standard / hollow drill bits)	C1	M10 to M30	Tables: C15.1 C16.2 C17.1	-1)	$\phi 10$ to $\phi 32$	Tables: C16.1 C16.2 C17.2	-1)		
	C2	M12 M16 M20 M24	Tables: C15.1 C16.2 C18.1						
Use category	I1 dry or wet concrete	all sizes							
	I2 water filled hole	all sizes (not permitted in combined with working life 100 years)							
Installation direction	D3 (downward and horizontal and upwards (e.g. overhead) installation)								
Installation temperature	$T_{i,min} = -5 \text{ °C}$ to $T_{i,max} = +40 \text{ °C}$								
In-service temperature	Temperature range I	-40 °C to +60 °C		(max. short term temperature +60 °C; max. long term temperature +35 °C)					
	Temperature range II	-40 °C to +72 °C		(max. short term temperature +72 °C; max. long term temperature +50 °C)					

<sup>1)</sup> no performance assessed

fischer injection system FIS EM Plus

**Intended use**  
Specifications (part 1)

**Annex B 1**  
Appendix 9/ 39

## Specifications of intended use (part 2)

### Base materials:

- Compacted reinforced or unreinforced normal weight concrete without fibres of strength classes C20/25 to C50/60 according to EN 206:2013+A1:2016

### Use conditions (Environmental conditions):

- Structures subject to dry internal conditions (zinc coated steel, stainless steel or high corrosion resistant steel).
- For all other conditions according to EN1993-1-4:2015 corresponding to corrosion resistance classes to Annex A 6 table A6.1.

### Design:

- Anchorages have to be designed by a responsible engineer with experience of concrete anchor design.
- Verifiable calculation notes and drawings are to be prepared taking account of the loads to be anchored. The position of the anchor is indicated on the design drawings (e. g. position of the anchor relative to reinforcement or to supports, etc.).
- Anchorages are designed in accordance with:  
EN 1992-4:2018 and EOTA Technical Report TR 055, Edition February 2018

### Installation:

- Anchor installation is to be carried out by appropriately qualified personnel and under the supervision of the person responsible for technical matters of the site
- In case of aborted hole: The hole shall be filled with mortar
- Anchorage depth should be marked and adhered to on installation
- Overhead installation is allowed

fischer injection system FIS EM Plus

**Intended use**  
Specifications (part 2)

**Annex B 2**  
Appendix 10/ 39

**Table B3.1: Installation parameters for anchor rods**

Anchor rods		Thread	M8	M10	M12	M14	M16	M20	M22	M24	M27	M30
Width across flats	SW	[mm]	13	17	19	22	24	30	32	36	41	46
Nominal drill hole diameter	$d_0$		10	12	14	16	18	22 24 <sup>1)</sup>	25	28	30	35
Drill hole depth	$h_0$		$h_0 = h_{ef}$									
Effective embedment depth	$h_{ef, min}$		60	60	70	75	80	90	93	96	108	120
	$h_{ef, max}$		160	200	240	280	320	400	440	480	540	600
Diameter of the clearance hole of the fixture	pre-positioned installation $d_f$		9	12	14	16	18	22	24	26	30	33
	push through installation $d_f$		12	14	16	18	20	26	28	30	33	40
Minimum thickness of concrete member	$h_{min}$	$h_{ef} + 30$ ( $\geq 100$ )				$h_{ef} + 2d_0$						
Maximum installation torque	$\max T_{inst}$	[Nm]	10	20	40	50	60	120	135	150	200	300

<sup>1)</sup> Both drill hole diameters can be used

**fischer anchor rod**

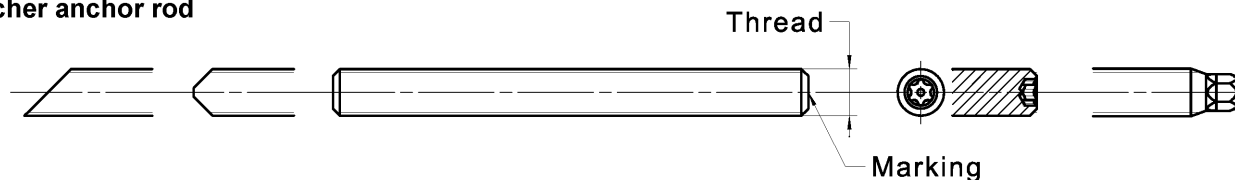

**Marking (on random place) fischer anchor rod:**

Steel zinc plated PC <sup>1)</sup> 8.8	• or +	Steel hot-dip PC <sup>1)</sup> 8.8	•
High corrosion resistant steel HCR PC <sup>1)</sup> 50	•	High corrosion resistant steel HCR PC <sup>1)</sup> 70	-
High corrosion resistant steel HCR PC <sup>1)</sup> 80	(	Stainless steel R property class 50	~
Stainless steel R property class 80	*		

Alternatively: Colour coding according to DIN 976-1:2016

<sup>1)</sup> PC = property class

**Installation conditions:**

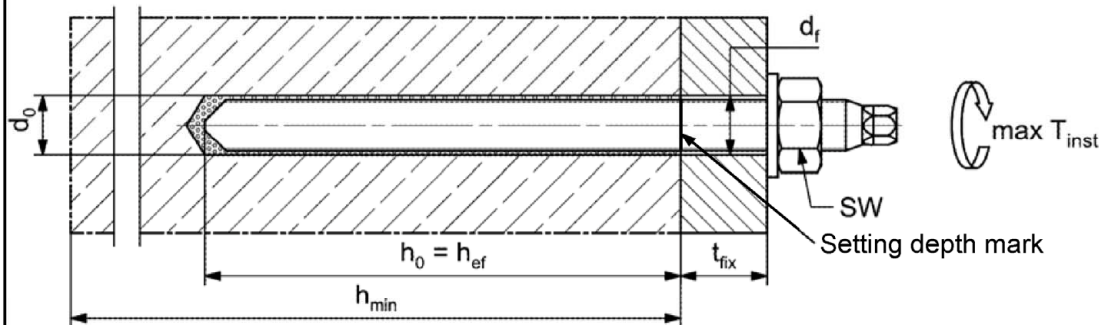

**Commercial standard threaded rods, washers and hexagon nuts may also be used if the following requirements are fulfilled**

- Materials, dimensions and mechanical properties according to Annex A 6, Table A6.1
- Inspection certificate 3.1 according to EN 10204:2004, the documents have to be stored
- Setting depth is marked

Figures not to scale

fischer injection system FIS EM Plus

**Intended use**

Installation parameters anchor rods

**Annex B 3**

Appendix 11/ 39

**Table B4.1:** Minimum spacing and minimum edge distance for **anchor rods** and **reinforcing bars**

Anchor rods		M8	M10	M12	M14	M16	-	M20	M22	M24
Reinforcing bars (nominal diameter) $\phi$		8	10	12	14	16	18	20	22	24
<b>Minimum edge distance</b>										
Uncracked / cracked concrete	$c_{min}$	[mm]	40	45	45	45	50	55	55	60
Minimum spacing	$s_{min}$		according to Annex B5							
<b>Minimum spacing</b>										
Uncracked / cracked concrete	$s_{min}$	[mm]	40	45	55	60	65	85	85	105
Minimum edge distance	$c_{min}$		according to Annex B5							
<b>Required projecting area</b>										
Uncracked concrete	$A_{sp,req}$	[1000 mm <sup>2</sup> ]	8	13	22	23	24	38,5	38,5	40
Cracked concrete			6,5	10	16,5	17,5	18,5	29,5	29,5	30,5
<b>Anchor rods</b>										
		-	-	M27	-	M30	-	-	-	-
<b>Reinforcing bars (nominal diameter) <math>\phi</math></b>		<b>25</b>	<b>26</b>	<b>-</b>	<b>28</b>	<b>30</b>	<b>32</b>	<b>34</b>	<b>36</b>	<b>40</b>
<b>Minimum edge distance</b>										
Uncracked / cracked concrete	$c_{min}$	[mm]	75	75	75	80	80	120	120	175
Minimum spacing	$s_{min}$		according to Annex B5							
<b>Minimum spacing</b>										
Uncracked / cracked concrete	$s_{min}$	[mm]	120	120	120	140	140	160	160	160
Minimum edge distance	$c_{min}$		according to Annex B5							
<b>Required projecting area</b>										
Uncracked concrete	$A_{sp,req}$	[1000 mm <sup>2</sup> ]	47,5	47,5	47,5	64	64	64	64	64
Cracked concrete			36,5	36,5	36,5	49	49	49	49	49

**Splitting failure** for minimum edge distance and spacing in dependence of the effective embedment depth  $h_{ef}$ .

For the calculation of minimum spacing and minimum edge distance of anchors in combination with different embedment depths and thicknesses of concrete members the following equation shall be fulfilled:

$$A_{sp,req} < A_{sp,t}$$

$A_{sp,req}$  = required projecting area

$A_{sp,t} = A_{sp,ef}$  = effective projecting area (according to Annex B5)

fischer injection system FIS EM Plus

**Intended use**

Minimum spacing and edge distance for anchor rods and reinforcing bars

**Annex B 4**

Appendix 12/ 39

**Table B5.1:** Effective projecting area  $A_{sp,t}$  with concrete member thickness  $h > h_{ef} + 1,5 \cdot c$  and  $h \geq h_{min}$

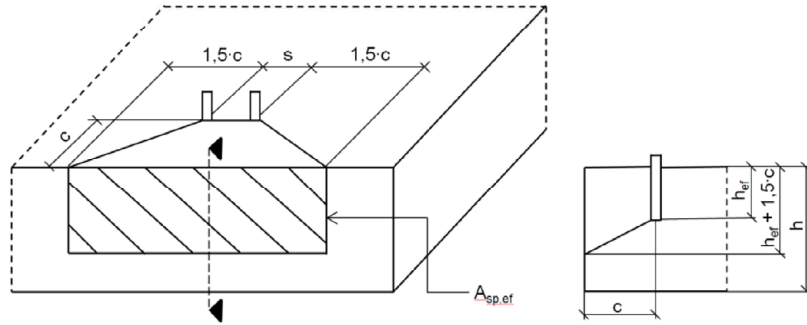

Single anchor	$A_{sp,t} = (3 \cdot c) \cdot (h_{ef} + 1,5 \cdot c)$	[mm <sup>2</sup> ]	with $c \geq c_{min}$
Group of anchors with $s > 3 \cdot c$	$A_{sp,t} = (6 \cdot c) \cdot (h_{ef} + 1,5 \cdot c)$	[mm <sup>2</sup> ]	
Group of anchors with $s \leq 3 \cdot c$	$A_{sp,t} = (3 \cdot c + s) \cdot (h_{ef} + 1,5 \cdot c)$	[mm <sup>2</sup> ]	with $c \geq c_{min}$ and $s \geq s_{min}$

**Table B5.2:** Effektive projecting area  $A_{sp,t}$  with concrete member thickness  $h \leq h_{ef} + 1,5 \cdot c$  and  $h \geq h_{min}$

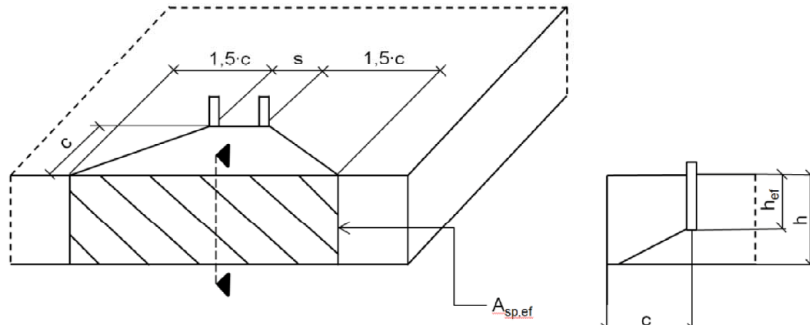

Single anchor	$A_{sp,t} = 3 \cdot c \cdot \text{existing } h$	[mm <sup>2</sup> ]	with $c \geq c_{min}$
Group of anchors with $s > 3 \cdot c$	$A_{sp,t} = 6 \cdot c \cdot \text{existing } h$	[mm <sup>2</sup> ]	
Group of anchors with $s \leq 3 \cdot c$	$A_{sp,t} = (3 \cdot c + s) \cdot \text{existing } h$	[mm <sup>2</sup> ]	with $c \geq c_{min}$ and $s \geq s_{min}$

Edge distance and axial spacing shall be rounded up to at least 5 mm

Figures not to scale

fischer injection system FIS EM Plus

**Intended use**

Minimum thickness of concrete member for anchor rods,  
minimum spacing and edge distance

**Annex B 5**  
Appendix 13/ 39

**Table B6.1:** Installation parameters for **fischer internal threaded anchors RG MI**

Internal threaded anchors RG MI		Thread	M8	M10	M12	M16	M20
Diameter of anchor	$d_{nom} = d_H$	[mm]	12	16	18	22	28
Nominal drill hole diameter	$d_0$		14	18	20	24	32
Drill hole depth	$h_0$		$h_0 = h_{ef} = L_H$				
Effective embedment depth ( $h_{ef} = L_H$ )	$h_{ef}$		90	90	125	160	200
Minimum spacing and minimum edge distance	$S_{min} = C_{min}$		55	65	75	95	125
Diameter of clearance hole in the fixture	$d_f$		9	12	14	18	22
Minimum thickness of concrete member	$h_{min}$		120	125	165	205	260
Maximum screw-in depth	$l_{E,max}$		18	23	26	35	45
Minimum screw-in depth	$l_{E,min}$		8	10	12	16	20
Maximum installation torque	$\max T_{inst}$		[Nm]	10	20	40	80

**fischer internal threaded anchor RG MI**

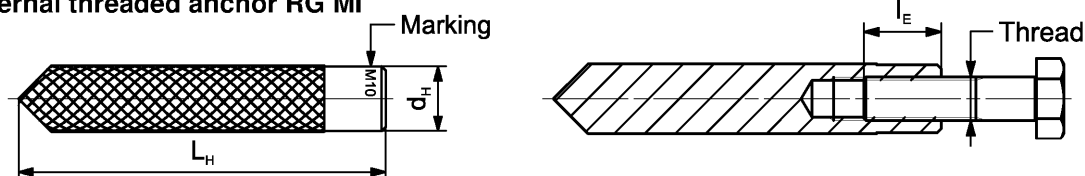

**Marking:** Anchor size e. g.: **M10**  
 Stainless steel → additional **R**; e.g.: **M10 R**  
 High corrosion resistant steel → additional **HCR**; e.g.: **M10 HCR**

Retaining bolt or threaded rods (including nut and washer) must comply with the appropriate material and strength class of Annex A 6, Table A6.1

**Installation conditions:**

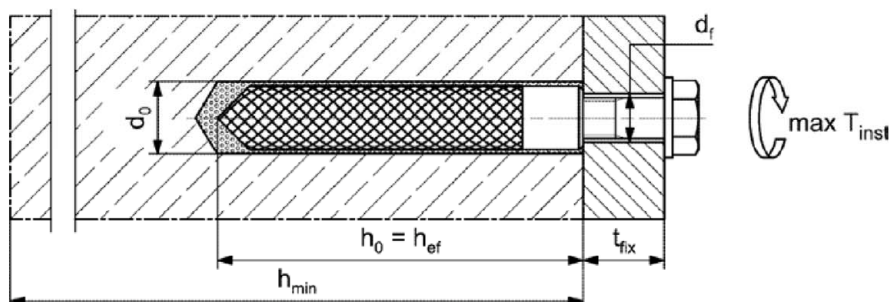

Figures not to scale

fischer injection system FIS EM Plus

**Intended use**

Installation parameters internal threaded anchors RG MI

**Annex B 6**

Appendix 14/ 39

**Table B7.1:** Installation parameters for reinforcing bars <sup>1)</sup>

Nominal diameter of the bar		$\phi$	8 <sup>2)</sup>	10 <sup>2)</sup>	12 <sup>2)</sup>	14	16	18	20	22	24				
Nominal drill hole diameter	$d_0$	[mm]	10	12	12	14	14	16	18	20	25	25	30	30	
Drill hole depth	$h_0$		$h_0 = h_{ef}$												
Effective embedment depth	$h_{ef,min}$		60	60	70	75	80	85	90	94	98				
	$h_{ef,max}$		160	200	240	280	320	360	400	440	480				
Minimum thickness of concrete member	$h_{min}$		$h_{ef} + 30$ ( $\geq 100$ )				$h_{ef} + 2d_0$								

Nominal diameter of the bar		$\phi$	25	26	28	30	32	34	36	40	-	
Nominal drill hole diameter	$d_0$	[mm]	30	35	35	40	40	40	45	55	-	
Drill hole depth	$h_0$		$h_0 = h_{ef}$									
Effective embedment depth	$h_{ef,min}$		100	104	112	120	128	136	144	160	-	
	$h_{ef,max}$		500	520	560	600	640	680	720	800	-	
Minimum thickness of concrete member	$h_{min}$		$h_{ef} + 2d_0$									

<sup>1)</sup> minimum spacing and minimum edge distance see Annex B 4

<sup>2)</sup> Both drill hole diameters can be used

**Reinforcing bar**



- The minimum value of related rib area  $f_{R,min}$  must fulfil the requirements of EN 1992-1-1:2004+AC:2010
- The rib height must be within the range:  $0,05 \cdot \phi \leq h_{rib} \leq 0,07 \cdot \phi$   
( $\phi$  = Nominal diameter of the bar,  $h_{rib}$  = rib height)

**Installation conditions:**

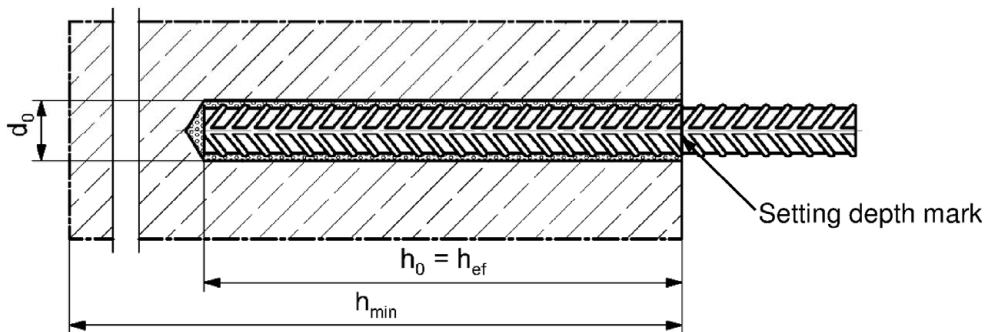

Figures not to scale

fischer injection system FIS EM Plus

**Intended use**

Installation parameters reinforcing bars

**Annex B 7**

Appendix 15/ 39

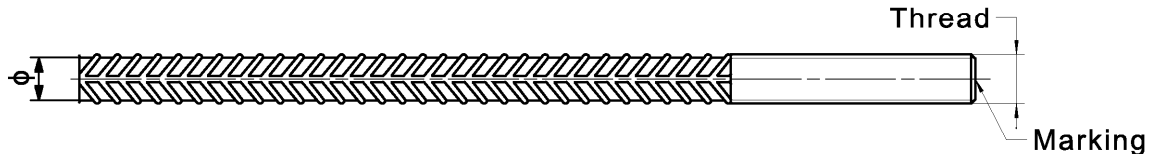



**Table B8.1:** Installation parameters for **fischer rebar anchor FRA**

Rebar anchor FRA		Thread	M12 <sup>1)</sup>	M16	M20	M24
Nominal diameter of the bar	$\phi$	[mm]	12	16	20	25
Width across flats	SW		19	24	30	36
Nominal drill hole diameter	$d_0$		14	16	20	30
Drill hole depth	$h_0$		$h_{ef} + l_e$			
Effective embedment depth	$h_{ef,min}$		70	80	90	96
	$h_{ef,max}$		140	220	300	380
Distance concrete surface to welded joint	$l_e$		100			
Minimum spacing and minimum edge distance	$s_{min}$ = $c_{min}$		55	65	85	105
	Diameter of pre-positioned anchorage		$\leq d_f$	14	18	22
Diameter of clearance hole in the fixture	push through anchorage		$\leq d_f$	18	22	26
Minimum thickness of concrete member	$h_{min}$	$h_0 + 30$	$h_0 + 2d_0$			
Maximum installation torque	$\max T_{inst}$	[Nm]	40	60	120	150

<sup>1)</sup> Both drill hole diameters can be used

**fischer rebar anchor FRA**



Marking frontal e. g:  FRA (for stainless steel);  FRA HCR (for high corrosion resistant steel)

**Installation conditions:**

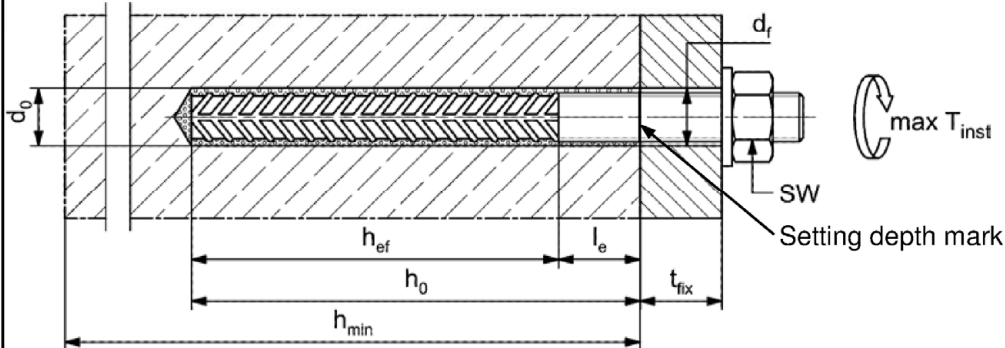

Figures not to scale

fischer injection system FIS EM Plus

**Intended use**

Installation parameters rebar anchor FRA

**Annex B 8**

Appendix 16/ 39

**Table B9.1: Parameters of the cleaning brush BS / BSB (steel brush with steel bristles)**

The size of the cleaning brush refers to the drill hole diameter

Nominal drill hole diameter	$d_0$		10	12	14	16	18	20	24	25	28	30	32	35	40	45	55
Steel brush diameter BS	$d_b$	[mm]	11	14	16	20		25	26	27	30	40			-	-	-
Steel brush diameter BSB	$d_b$		-	-	-	-		-	-	-	-	-			42	47	58

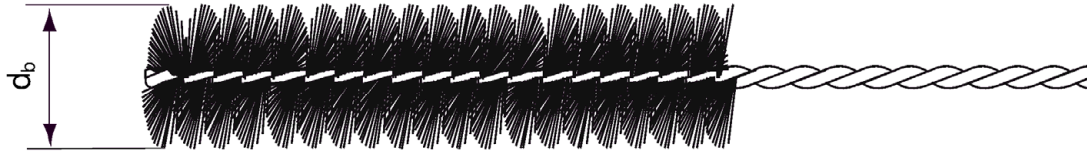

**Table B9.2 Maximum processing time** of the mortar and **minimum curing time** (During the curing time of the mortar the concrete temperature may not fall below the listed minimum temperature)

Temperature at anchoring base [°C]	Maximum processing time $t_{work}$	Minimum curing time <sup>1)</sup> $t_{cure}$
-5 to 0 <sup>2)</sup>	240 min	200 h
> 0 to 5 <sup>2)</sup>	150 min	90 h
> 5 to 10	120 min	40 h
> 10 to 20	30 min	18 h
> 20 to 30	14 min	10 h
> 30 to 40	7 min	5 h

<sup>1)</sup> In wet concrete or water filled holes the curing times must be doubled

<sup>2)</sup> Minimal cartridge temperature +5°C





fischer injection system FIS EM Plus

**Intended use**

Cleaning brush (steel brush)  
Processing time and curing time

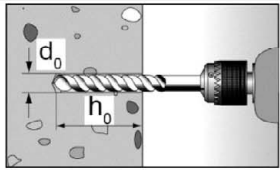
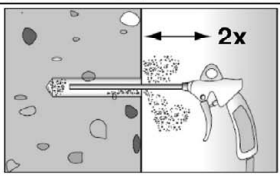
## Installation instructions part 1

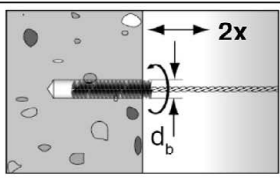
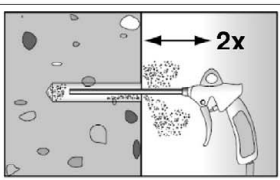
### Drilling and cleaning the hole (hammer drilling with standard drill bit)

1		<p>Drill the hole. Nominal drill hole diameter <math>d_0</math> and drill hole depth <math>h_0</math> see <b>tables B3.1, B6.1, B7.1, B8.1</b></p>
2		<p>Cleaning the drill hole: Blow out the drill hole twice, with oil free compressed air (<math>p \geq 6</math> bar)</p> 
3		<p>Brush the drill hole twice. For drill hole diameter <math>\geq 30</math> mm use a power drill. For deep holes use an extension. Corresponding brushes see <b>table B9.1</b></p>
4		<p>Cleaning the drill hole: Blow out the drill hole twice, with oil free compressed air (<math>p \geq 6</math> bar)</p> 

Go to step 6

### Drilling and cleaning the hole (hammer drilling with hollow drill bit)

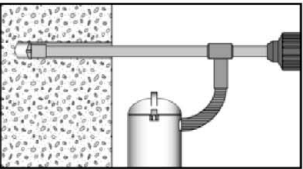
1		<p>Check a suitable hollow drill (see <b>table B1.1</b>) for correct operation of the dust extraction</p>
2		<p>Use a suitable dust extraction system, e. g. fischer FVC 35 M or a comparable dust extraction system with equivalent performance data</p> <p>Drill the hole with hollow drill bit. The dust extraction system has to extract the drill dust nonstop during the drilling process and must be adjusted to maximum power. Nominal drill hole diameter <math>d_0</math> and drill hole depth <math>h_0</math> see <b>tables B3.1, B6.1, B7.1, B8.1</b></p>

Go to step 6

fischer injection system FIS EM Plus

**Intended use**  
Installation instructions part 1



**Annex B 10**  
Appendix 18/ 39

## Installation instructions part 2

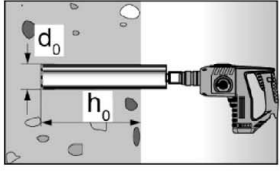
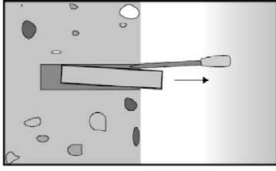
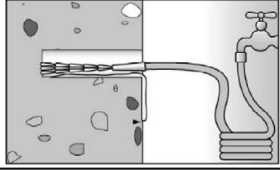
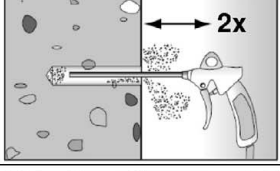
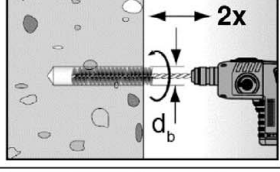
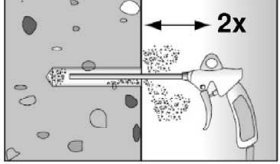
### Drilling and cleaning the hole (wet drilling with diamond drill bit)

1		<p>Drill the hole. Drill hole diameter <math>d_0</math> and nominal drill hole depth <math>h_0</math> see tables <b>B3.1</b>, <b>B6.1</b>, <b>B7.1</b>, <b>B8.1</b></p>		<p>Break the drill core and remove it</p>
2		<p>Flush the drill hole with clean water until it flows clear</p>		
3		<p>Blow out the drill hole twice, using oil-free compressed air (<math>p &gt; 6</math> bar)</p>		
4		<p>Brush the drill hole twice using a power drill. Corresponding brushes see table <b>B9.1</b></p>		
5		<p>Blow out the drill hole twice, using oil-free compressed air (<math>p &gt; 6</math> bar)</p>		

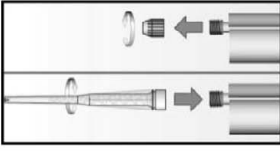
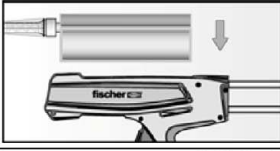
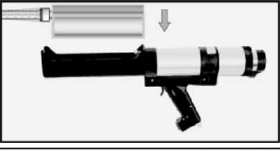
### Preparing the cartridge

6		<p>Remove the sealing cap Screw on the static mixer (the spiral in the static mixer must be clearly visible)</p>		
7			<p>Place the cartridge into the dispenser</p>	
8			<p>Extrude approximately 10 cm of material out until the resin is evenly grey in colour. Do not use mortar that is not uniformly grey</p>	

fischer injection system FIS EM Plus

**Intended use**  
Installation instructions part 2



**Annex B 11**  
Appendix 19/ 39

### Installation instructions part 3

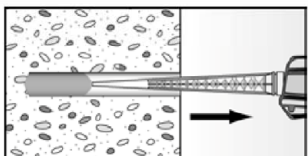
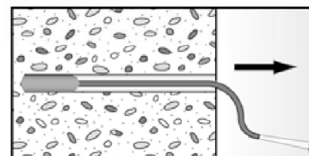
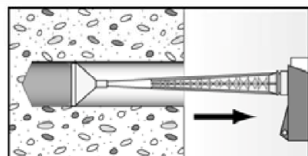
#### Injection of the mortar

<p>9</p>	 <p>Fill approximately 2/3 of the drill hole with mortar. Always begin from the bottom of the hole and avoid bubbles</p>	 <p>For drill hole depth <math>\geq 150</math> mm use an extension tube</p>	 <p>For overhead installation, deep holes (<math>h_0 &gt; 250</math> mm) or drill hole diameter (<math>d_0 \geq 40</math> mm) use an injection-adapter</p>
----------	---	--	---

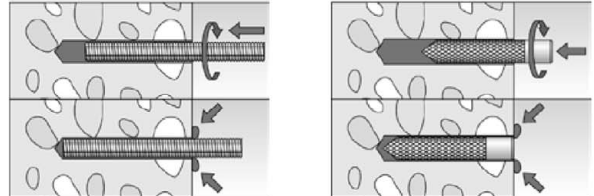
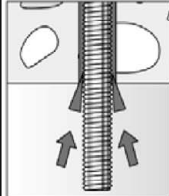
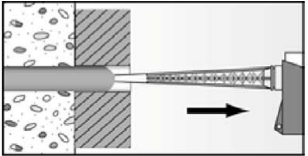
#### Installation of anchor rods or fischer internal threaded anchors RG MI

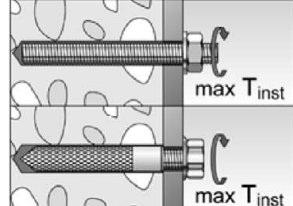
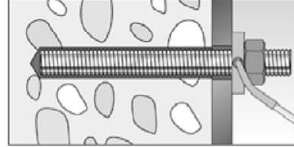
<p>10</p>		<p>Only use clean and oil-free metal parts. Mark the setting depth of the metal parts. Push the anchor rod or fischer internal threaded RG MI anchor down to the bottom of the hole, turning it slightly while doing so. After inserting the metal part, excess mortar must be emerged around the anchor element.</p>
	 <p>For overhead installations support the metal part with wedges (e. g. fischer centering wedges) or fischer overhead clips.</p>	 <p>For push through installation fill the annular gap with mortar</p>
<p>11</p>	 <p>Wait for the specified curing time <math>t_{cure}</math> see <b>table B9.2</b></p>	<p>12</p>  <p>Mounting the fixture <math>\max T_{inst}</math> see <b>tables B3.1 and B6.1</b></p>
<p>Option</p>		<p>After the minimum curing time is reached, the gap between metal part and fixture (annular clearance) may be filled with mortar via the fischer filling disc. Compressive strength <math>\geq 50</math> N/mm<sup>2</sup> (e.g. fischer injection mortars FIS HB, FIS SB, FIS V, FIS EM Plus)  <b>ATTENTION:</b> Using fischer filling disc reduces <math>t_{fix}</math> (usable length of the anchor)</p>



fischer injection system FIS EM Plus

**Intended use**  
Installation instructions part 3

**Annex B 12**  
Appendix 20/ 39

## Installation instructions part 4

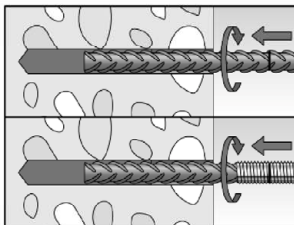
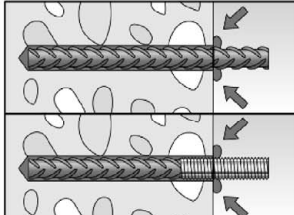
### Installation reinforcing bars and fischer rebar anchor FRA

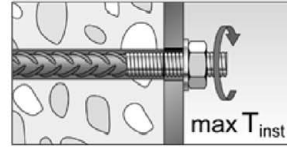
10		Only use clean and oil-free reinforcing bars or fischer FRA. Mark the setting depth. Turn while using force to push the reinforcement bar or the fischer FRA into the filled hole up to the setting depth mark		
10		When the setting depth mark is reached, excess mortar must be emerged from the mouth of the drill hole.		
11	 <p>Wait for the specified curing time <math>t_{cure}</math> see <b>table B9.2</b></p>	12	 <p>max <math>T_{inst}</math></p>	Mounting the fixture max $T_{inst}$ see <b>table B8.1</b>

fischer injection system FIS EM Plus

**Intended use**  
Installation instructions part 4

**Annex B 13**  
Appendix 21/ 39

**Table C1.1:** Characteristic values for **steel failure** under tension / shear load of **fischer anchor rods** and **standard threaded rods**

Anchor rod / standard threaded rod		M8	M10	M12	M14	M16	M20	M22	M24	M27	M30		
<b>Bearing capacity under tension load, steel failure<sup>3)</sup></b>													
Characteristic resistance $N_{Rk,s}$	Steel zinc plated	Property class 4.8	[kN]	15(13)	23(21)	33	46	63	98	121	141	184	224
		5.8		19(17)	29(27)	43	58	79	123	152	177	230	281
		8.8		29(27)	47(43)	68	92	126	196	243	282	368	449
	Stainless steel R and high corrosion resistant steel HCR	50		19	29	43	58	79	123	152	177	230	281
		70		26	41	59	81	110	172	212	247	322	393
		80		30	47	68	92	126	196	243	282	368	449
<b>Partial factors <sup>1)</sup></b>													
Partial factor $\gamma_{Ms,N}$	Steel zinc plated	Property class 4.8	[-]	1,50									
		5.8		1,50									
		8.8		1,50									
	Stainless steel R and high corrosion resistant steel HCR	50		2,86									
		70		1,50 <sup>2)</sup> / 1,87									
		80		1,60									
<b>Bearing capacity under shear load, steel failure<sup>3)</sup></b>													
<b>without lever arm</b>													
Characteristic resistance $V_{Rk,s}^0$	Steel zinc plated	Property class 4.8	[kN]	9(8)	14(13)	20	28	38	59	73	85	110	135
		5.8		11(10)	17(16)	25	34	47	74	91	106	138	168
		8.8		15(13)	23(21)	34	46	63	98	122	141	184	225
	Stainless steel R and high corrosion resistant steel HCR	50		9	15	21	29	39	61	76	89	115	141
		70		13	20	30	40	55	86	107	124	161	197
		80		15	23	34	46	63	98	122	141	184	225
Ductility factor	k <sub>7</sub>	[-]	1,0										
<b>with lever arm</b>													
Charact. resistance $M_{Rk,s}^0$	Steel zinc plated	Property class 4.8	[Nm]	15(13)	30(27)	52	83	133	259	357	448	665	899
		5.8		19(16)	37(33)	65	104	166	324	447	560	833	1123
		8.8		30(26)	60(53)	105	167	266	519	716	896	1333	1797
	Stainless steel R and high corrosion resistant steel HCR	50		19	37	65	104	166	324	447	560	833	1123
		70		26	52	92	146	232	454	626	784	1167	1573
		80		30	60	105	167	266	519	716	896	1333	1797
<b>Partial factors <sup>1)</sup></b>													
Partial factor $\gamma_{Ms,V}$	Steel zinc plated	Property class 4.8	[-]	1,25									
		5.8		1,25									
		8.8		1,25									
	Stainless steel R and high corrosion resistant steel HCR	50		2,38									
		70		1,25 <sup>2)</sup> / 1,56									
		80		1,33									

<sup>1)</sup> In absence of other national regulations

<sup>2)</sup> Only admissible for high corrosion resist. steel HCR, with  $f_{yk}/f_{uk} \geq 0,8$  and  $A_5 > 12\%$  (e.g. fischer anchor rods)

<sup>3)</sup> Values in brackets are valid for undersized threaded rods with smaller stress area  $A_s$  for hot dip galvanised standard threaded rods according to EN ISO 10684:2004+AC:2009

fischer injection system FIS EM Plus

**Performances**

Characteristic values for steel failure under tension / shear load of fischer anchor rods and standard threaded rods

**Annex C 1**

Appendix 22/ 39

**Table C2.1:** Characteristic values for **steel failure** under tension / shear load of **fischer internal threaded anchors RG MI**

fischer internal threaded anchors RG MI				M8	M10	M12	M16	M20
<b>Bearing capacity under tension load, steel failure</b>								
Charact. resistance with screw	Property class	5.8	[kN]	19	29	43	79	123
		8.8		29	47	68	108	179
		R		26	41	59	110	172
		HCR		26	41	59	110	172
<b>Partial factors<sup>1)</sup></b>								
Partial factors	$\gamma_{Ms,N}$	5.8	[-]	1,50				
		8.8		1,50				
		R		1,87				
		HCR		1,87				
<b>Bearing capacity under shear load, steel failure</b>								
<b>Without lever arm</b>								
Charact. resistance with screw	Property class	5.8	[kN]	9,2	14,5	21,1	39,2	62,0
		8.8		14,6	23,2	33,7	54,0	90,0
		R		12,8	20,3	29,5	54,8	86,0
		HCR		12,8	20,3	29,5	54,8	86,0
Ductility factor		$k_7$	[-]	1,0				
<b>With lever arm</b>								
Charact. resistance with screw	Property class	5.8	[Nm]	20	39	68	173	337
		8.8		30	60	105	266	519
		R		26	52	92	232	454
		HCR		26	52	92	232	454
<b>Partial factors<sup>1)</sup></b>								
Partial factors	$\gamma_{Ms,V}$	5.8	[-]	1,25				
		8.8		1,25				
		R		1,56				
		HCR		1,56				

<sup>1)</sup> In absence of other national regulations



**Table C3.1:** Characteristic values for **steel failure** under tension / shear load of **reinforcing bars**

Nominal diameter of the bar	$\phi$	8	10	12	14	16	18	20	22	24	25	26	28	30	32	34	36	40	
<b>Bearing capacity under tension load, steel failure</b>																			
Characteristic resistance	$N_{Rk,s}$	[kN]	$A_s \cdot f_{uk}^{1)}$																
<b>Bearing capacity under shear load, steel failure</b>																			
<b>Without lever arm</b>																			
Characteristic resistance	$V_{Rk,s}^0$	[kN]	$0,5 \cdot A_s \cdot f_{uk}^{1)}$																
Ductility factor	$k_7$	[-]	1,0																
<b>With lever arm</b>																			
Characteristic resistance	$M_{Rk,s}^0$	[Nm]	$1,2 \cdot W_{el} \cdot f_{uk}^{1)}$																

<sup>1)</sup>  $f_{uk}$  or  $f_{yk}$  respectively must be taken from the specifications of the reinforcing bar

**Table C3.2:** Characteristic values for **steel failure** under tension / shear load of **fischer rebar anchors FRA**

fischer rebar anchor FRA		M12	M16	M20	M24	
<b>Bearing capacity under tension load, steel failure</b>						
Characteristic resistance	$N_{Rk,s}$	[kN]	63	111	173	270
<b>Partial factor<sup>1)</sup></b>						
Partial factor	$\gamma_{Ms,N}$	[-]	1,4			
<b>Bearing capacity under shear load, steel failure</b>						
<b>Without lever arm</b>						
Characteristic resistance	$V_{Rk,s}^0$	[kN]	30	55	86	124
Ductility factor	$k_7$	[-]	1,0			
<b>With lever arm</b>						
Characteristic resistance	$M_{Rk,s}^0$	[Nm]	92	233	454	785
<b>Partial factor<sup>1)</sup></b>						
Partial factor	$\gamma_{Ms,V}$	[-]	1,56			

<sup>1)</sup> In absence of other national regulations

fischer injection system FIS EM Plus	<b>Annex C 3</b> Appendix 24/ 39
<b>Performances</b> Characteristic values for steel failure under tension / shear load of reinforcing bars and fischer rebar anchors FRA	

Table C4.1: Characteristic values for concrete failure under tension / shear load																					
<b>Size</b>				<b>All sizes</b>																	
<b>Tension load</b>																					
Installation factor		$\gamma_{inst}$	[-]	See annex C 5 to C 12 and C 17 to C 18																	
<b>Factors for the compressive strength of concrete &gt; C20/25</b>																					
Increasing factor for $\tau_{RK}$	C25/30		$\Psi_c$	[-]	1,02																
	C30/37				1,04																
	C35/45				1,06																
	C40/50				1,07																
	C45/55				1,08																
	C50/60				1,09																
<b>Splitting failure</b>																					
Edge distance	$h / h_{ef} \geq 2,0$		$C_{cr,sp}$	[mm]	1,0 $h_{ef}$																
	$2,0 > h / h_{ef} > 1,3$				4,6 $h_{ef} - 1,8 h$																
	$h / h_{ef} \leq 1,3$				2,26 $h_{ef}$																
Spacing		$S_{cr,sp}$	2 $C_{cr,sp}$																		
<b>Concrete cone failure</b>																					
Uncracked concrete		$k_{ucr,N}$	[-]	11,0																	
Cracked concrete		$k_{cr,N}$		7,7																	
Edge distance		$C_{cr,N}$	[mm]	1,5 $h_{ef}$																	
Spacing		$S_{cr,N}$		2 $C_{cr,N}$																	
<b>Factors for sustained tension load</b>																					
Factor		$\Psi_{sus}^0$	[-]	-1)																	
<b>Shear load</b>																					
Installation factor		$\gamma_{inst}$	[-]	1,0																	
<b>Concrete pry-out failure</b>																					
Factor for pry-out failure		$k_8$	[-]	2,0																	
<b>Concrete edge failure</b>																					
Effective length of fastener in shear loading		$l_f$	[mm]	for $d_{nom} \leq 24$ mm: min ( $h_{ef}$ , 12 $d_{nom}$ ) for $d_{nom} > 24$ mm: min ( $h_{ef}$ , 8 $d_{nom}$ ; 300 mm)																	
<b>Calculation diameters</b>																					
Size			M8	M10	M12	M14	M16	M20	M22	M24	M27	M30									
fischer anchor rods and standard threaded rods		$d_{nom}$	[mm]	8	10	12	14	16	20	22	24	27	30								
fischer internal threaded anchors RG MI		$d_{nom}$		12	16	18	-2)	22	28	-2)	-2)	-2)	-2)								
fischer rebar anchor FRA		$d_{nom}$		-2)	-2)	12	-2)	16	20	-2)	25	-2)	-2)								
Size (nominal diameter of the bar)			$\phi$	8	10	12	14	16	18	20	22	24	25	26	28	30	32	34	36	40	
Reinforcing bar			$d_{nom}$	[mm]	8	10	12	14	16	18	20	22	24	25	26	28	30	32	34	36	40
1) No performance assessed																					
2) Anchor type not part of the ETA																					
fischer injection system FIS EM Plus											<b>Annex C 4</b> Appendix 25/ 39										
<b>Performances</b> Characteristic values for concrete failure under tension / shear load																					

**Table C5.1:** Characteristic values for **combined pull-out** and concrete failure for **fischer anchor rods** and **standard threaded rods** in hammer or diamond drilled holes; **uncracked or cracked concrete; working life 50 years**

Anchor rod / standard threaded rod		M8	M10	M12	M14	M16	M20	M22	M24	M27	M30	
<b>Uncracked concrete</b>												
<b>Characteristic bond resistance in uncracked concrete C20/25</b>												
<u>Hammer-drilling with standard drill bit or hollow drill bit (dry or wet concrete)</u>												
Temperature range	I: 35 °C / 60 °C	$\tau_{Rk,ucr}$ [N/mm <sup>2</sup> ]	18	18	18	17	17	16	15	15	15	14
	II: 50 °C / 72 °C		18	17	17	16	16	15	14	14	14	13
<u>Hammer-drilling with standard drill bit or hollow drill bit (water filled hole)</u>												
Temperature range	I: 35 °C / 60 °C	$\tau_{Rk,ucr}$ [N/mm <sup>2</sup> ]	16	16	15	13	13	11	11	10	10	9
	II: 50 °C / 72 °C		15	14	14	13	12	11	10	10	9	9
<u>Diamond-drilling (dry or wet concrete as well as water filled hole)</u>												
Temperature range	I: 35 °C / 60 °C	$\tau_{Rk,ucr}$ [N/mm <sup>2</sup> ]	16	15	13	12	12	10	10	10	9	9
	II: 50 °C / 72 °C		15	14	12	11	11	10	9	9	8	8
<b>Installation factors</b>												
Dry or wet concrete	$\gamma_{inst}$	[-]	1,0									
Water filled hole			1,4									
<b>Cracked concrete</b>												
<b>Characteristic bond resistance in cracked concrete C20/25</b>												
<u>Hammer-drilling with standard drill bit or hollow drill bit (dry or wet concrete)</u>												
Temperature range	I: 35 °C / 60 °C	$\tau_{Rk,cr}$ [N/mm <sup>2</sup> ]	7,5	7,5	9	8,5	8,5	8,5	8,5	8,5	8,5	8,5
	II: 50 °C / 72 °C		7,5	7,5	9	8,5	8,5	8,5	8,5	8,5	8,5	8,5
<u>Diamond - drilling (dry or wet concrete)</u>												
Temperature range	I: 35 °C / 60 °C	$\tau_{Rk,cr}$ [N/mm <sup>2</sup> ]	7	7	7	7	6	6	7	7	7	7
	II: 50 °C / 72 °C		7	7	7	7	6	6	7	7	7	7
<u>Hammer-drilling with standard drill bit or hollow drill bit and diamond-drilling (water filled hole)</u>												
Temperature range	I: 35 °C / 60 °C	$\tau_{Rk,cr}$ [N/mm <sup>2</sup> ]	6	7,5	7,5	7	6	6	6	6	6	6
	II: 50 °C / 72 °C		6	7	7	7	6	6	6	6	6	6
<b>Installation factors</b>												
Dry or wet concrete	$\gamma_{inst}$	[-]	1,0									
Water filled hole			1,2				1,4					
fischer injection system FIS EM Plus											Annex C 5 Appendix 26/ 39	
<b>Performances</b> Characteristic values for combined pull-out and concrete failure for fischer anchor rod and standard threaded rods; working life 50 years												

**Table C6.1:** Characteristic values for **combined pull-out** and concrete failure for **fischer anchor rods** and **standard threaded rods** in hammer or diamond drilled holes; **uncracked or cracked concrete; working life 100 years**

Anchor rod / standard threaded rod		M8	M10	M12	M14	M16	M20	M22	M24	M27	M30			
<b>Combined pullout and concrete cone failure</b>														
Calculation diameter	d	[mm]	8	10	12	14	16	20	22	24	27	30		
<b>Uncracked concrete</b>														
<b>Characteristic bond resistance in uncracked concrete C20/25</b>														
Hammer-drilling with standard drill bit or hollow drill bit (dry or wet concrete)														
Temperature range	I: 35 °C / 60 °C		$\tau_{Rk,ucr}$	[N/mm <sup>2</sup> ]	18	18	18	17	17	16	15	15	14	
	II: 50 °C / 72 °C				18	17	17	16	16	15	14	14	14	13
Diamond-drilling (dry or wet concrete)														
Temperature range	I: 35 °C / 60 °C		$\tau_{Rk,ucr}$	[N/mm <sup>2</sup> ]	16	15	13	12	12	10	10	10	9	9
	II: 50 °C / 72 °C				15	14	12	11	11	10	9	9	8	8
<b>Installation factors</b>														
Dry or wet concrete		$\gamma_{inst}$	[-]	1,0										
Working life 100 years	I: 35 °C / 60 °C		$\alpha_{100\text{ years}}$	[-]	0,75	0,75	0,75	0,75	0,75	0,75	0,75	0,75	0,75	0,75
	II: 50 °C / 72 °C				0,55	0,60	0,60	0,65	0,65	0,65	0,65	0,65	0,65	0,65
<b>Cracked concrete</b>														
<b>Characteristic bond resistance in cracked concrete C20/25</b>														
Hammer-drilling with standard drill bit or hollow drill bit (dry or wet concrete)														
Temperature range	I: 35 °C / 60 °C		$\tau_{Rk,cr}$	[N/mm <sup>2</sup> ]	7,5	7,5	9	8,5	8,5	8,5	8,5	8,5	8,5	8,5
	II: 50 °C / 72 °C				7,5	7,5	9	8,5	8,5	8,5	8,5	8,5	8,5	8,5
Diamond - drilling (dry or wet concrete)														
Temperature range	I: 35 °C / 60 °C		$\tau_{Rk,cr}$	[N/mm <sup>2</sup> ]	7	7	7	7	6	6	7	7	7	7
	II: 50 °C / 72 °C				7	7	7	7	6	6	7	7	7	7
<b>Installation factors</b>														
Dry or wet concrete		$\gamma_{inst}$	[-]	1,0										
Working life 100 years	I: 35 °C / 60 °C		$\alpha_{100\text{ years}}$	[-]	0,60	0,85	0,80	0,65	0,65	0,65	0,65	0,65	0,65	0,65
	II: 50 °C / 72 °C				0,60	0,85	0,80	0,65	0,65	0,65	0,65	0,65	0,65	0,65

1) **Calculation of characteristic bond resistance in uncracked concrete  $\tau_{Rk,100, ucr}$ :**

$$\tau_{Rk,100, ucr} = \alpha_{100\text{ years}} \cdot \tau_{Rk,ucr}$$

2) **Calculation of characteristic bond resistance in cracked concrete  $\tau_{Rk,100, cr}$ :**

$$\tau_{Rk,100, cr} = \alpha_{100\text{ years}} \cdot \tau_{Rk,cr}$$

fischer injection system FIS EM Plus

**Performances**

Characteristic values for combined pull-out and concrete failure for fischer anchor rod and standard threaded rods; working life 100 years

**Annex C 6**

Appendix 27/ 39

**Table C7.1:** Characteristic values for **combined pull-out** and concrete failure for **fischer internal threaded anchors RG MI** in hammer or diamond drilled holes; **uncracked or cracked concrete; working life 50 years**

Internal threaded anchor RG MI			M8	M10	M12	M16	M20	
<b>Combined pullout and concrete cone failure</b>								
Calculation diameter	d	[mm]	12	16	18	22	28	
<b>Uncracked concrete</b>								
<b>Characteristic bond resistance in uncracked concrete C20/25</b>								
<u>Hammer-drilling with standard drill bit or hollow drill bit (dry or wet concrete)</u>								
Temperature range	I: 35 °C / 60 °C	$\tau_{Rk,ucr}$	[N/mm <sup>2</sup> ]	15	14	14	13	12
	II: 50 °C / 72 °C			14	13	13	12	11
<u>Hammer-drilling with standard drill bit or hollow drill bit (water filled hole)</u>								
Temperature range	I: 35 °C / 60 °C	$\tau_{Rk,ucr}$	[N/mm <sup>2</sup> ]	14	12	12	11	10
	II: 50 °C / 72 °C			13	12	11	10	9
<u>Diamond-drilling (dry or wet concrete as well as water filled hole)</u>								
Temperature range	I: 35 °C / 60 °C	$\tau_{Rk,ucr}$	[N/mm <sup>2</sup> ]	13	12	11	10	9
	II: 50 °C / 72 °C			12	11	10	9	8
<b>Installation factors</b>								
Dry or wet concrete	$\gamma_{inst}$	[-]	1,0					
Water filled hole			1,4					
<b>Cracked concrete</b>								
<b>Characteristic bond resistance in cracked concrete C20/25</b>								
<u>Hammer-drilling with standard drill bit or hollow drill bit and diamond-drilling (dry or wet concrete)</u>								
Temperature range	I: 35 °C / 60 °C	$\tau_{Rk,cr}$	[N/mm <sup>2</sup> ]	7	6	6	7	7
	II: 50 °C / 72 °C			7	6	6	7	7
<u>Hammer-drilling with standard drill bit or hollow drill bit and diamond-drilling (water filled hole)</u>								
Temperature range	I: 35 °C / 60 °C	$\tau_{Rk,cr}$	[N/mm <sup>2</sup> ]	7	6,5	6	6	6
	II: 50 °C / 72 °C			7	6	6	6	6
<b>Installation factors</b>								
Dry or wet concrete	$\gamma_{inst}$	[-]	1,0					
Water filled hole			1,2			1,4		
fischer injection system FIS EM Plus								
<b>Performances</b> Characteristic values for combined pull-out and concrete failure for fischer internal threaded anchors RG MI; working life 50 years							<b>Annex C 7</b> Appendix 28/ 39	

**Table C8.1:** Characteristic values for **combined pull-out** and concrete failure for **fischer internal threaded anchors RG MI** in hammer or diamond drilled holes; **uncracked or cracked concrete; working life 100 years**

Internal threaded anchor RG MI			M8	M10	M12	M16	M20	
<b>Combined pullout and concrete cone failure</b>								
Calculation diameter	d	[mm]	12	16	18	22	28	
<b>Uncracked concrete</b>								
<b>Characteristic bond resistance in uncracked concrete C20/25</b>								
Hammer-drilling with standard drill bit or hollow drill bit (dry or wet concrete)								
Temperature range	I: 35 °C / 60 °C	$\tau_{Rk,ucr}$	[N/mm <sup>2</sup> ]	15	14	14	13	12
	II: 50 °C / 72 °C			14	13	13	12	11
Diamond-drilling (dry or wet concrete)								
Temperature range	I: 35 °C / 60 °C	$\tau_{Rk,ucr}$	[N/mm <sup>2</sup> ]	13	12	11	10	9
	II: 50 °C / 72 °C			12	11	10	9	8
<b>Installation factors</b>								
Dry or wet concrete	$\gamma_{inst}$	[-]	1,0					
Working life 100 years	I: 35 °C / 60 °C	$\alpha_{100\ years}$	[-]	0,75	0,75	0,75	0,75	0,75
	II: 50 °C / 72 °C			0,55	0,60	0,60	0,65	0,65
<b>Cracked concrete</b>								
<b>Characteristic bond resistance in cracked concrete C20/25</b>								
Hammer-drilling with standard drill bit or hollow drill bit and diamond-drilling (dry or wet concrete)								
Temperature range	I: 35 °C / 60 °C	$\tau_{Rk,cr}$	[N/mm <sup>2</sup> ]	7	6	6	7	7
	II: 50 °C / 72 °C			7	6	6	7	7
<b>Installation factors</b>								
Dry or wet concrete	$\gamma_{inst}$	[-]	1,0					
Working life 100 years	I: 35 °C / 60 °C	$\alpha_{100\ years}$	[-]	0,60	0,85	0,80	0,65	0,65
	II: 50 °C / 72 °C			0,60	0,85	0,80	0,65	0,65

1) Calculation of characteristic bond resistance in uncracked concrete  $\tau_{Rk,100, ucr}$  :

$$\tau_{Rk,100, ucr} = \alpha_{100\ years} \cdot \tau_{Rk,ucr}$$

2) Calculation of characteristic bond resistance in cracked concrete  $\tau_{Rk,100, cr}$  :

$$\tau_{Rk,100, cr} = \alpha_{100\ years} \cdot \tau_{Rk,cr}$$

fischer injection system FIS EM Plus

**Performances**

Characteristic values for combined pull-out and concrete failure for fischer internal threaded anchors RG MI; working life 100 years

**Table C9.1:** Characteristic values for **combined pull-out** and concrete failure for **reinforcing bars** in hammer or diamond drilled holes; **uncracked or cracked concrete; working life 50 years**

Nominal diameter of the bar		$\phi$	8	10	12	14	16	18	20	22	24	25	26	28	30	32	34	36	40		
<b>Combined pullout and concrete cone failure</b>																					
Calculation diameter		d	[mm]	8	10	12	14	16	18	20	22	24	25	26	28	30	32	34	36	40	
<b>Uncracked concrete</b>																					
<b>Characteristic bond resistance in uncracked concrete C20/25</b>																					
Hammer-drilling with standard drill bit or hollow drill bit (dry or wet concrete)																					
Temperature range	I: 35 °C / 60 °C		$\tau_{Rk,ucr}$	[N/mm <sup>2</sup> ]	16	15	15	14	14	13	13	13	12	12	12	12	12	11	11	11	
	II: 50 °C / 72 °C				15	14	14	13	13	12	12	12	12	11	11	11	11	11	11	11	10
Hammer-drilling with standard drill bit or hollow drill bit (water filled hole)																					
Temperature range	I: 35 °C / 60 °C		$\tau_{Rk,ucr}$	[N/mm <sup>2</sup> ]	16	16	14	13	12	12	11	11	10	10	10	10	9	9	9	8	8
	II: 50 °C / 72 °C				15	14	13	12	12	11	11	10	10	9	9	9	9	9	8	8	8
Diamond-drilling (dry or wet concrete as well as water filled hole)																					
Temperature range	I: 35 °C / 60 °C		$\tau_{Rk,ucr}$	[N/mm <sup>2</sup> ]	16	15	13	12	12	11	10	10	10	9	9	9	9	8	8	8	7
	II: 50 °C / 72 °C				15	14	12	11	11	10	10	9	9	9	8	8	8	8	7	7	7
<b>Installation factors</b>																					
Dry or wet concrete		$\gamma_{inst}$	[-]																	1,0	
Water filled hole																				1,4	
<b>Cracked concrete</b>																					
<b>Characteristic bond resistance in cracked concrete C20/25</b>																					
Hammer-drilling with standard drill bit or hollow drill bit (dry or wet concrete)																					
Temperature range	I: 35 °C / 60 °C		$\tau_{Rk,cr}$	[N/mm <sup>2</sup> ]	7	7	8	8	8	8	8	8	8	8	8	8	8	8	8	8	
	II: 50 °C / 72 °C				7	7	8	8	8	8	8	8	8	8	8	8	8	8	8	8	8
Diamond-drilling (dry or wet concrete)																					
Temperature range	I: 35 °C / 60 °C		$\tau_{Rk,cr}$	[N/mm <sup>2</sup> ]	7	7	7	7	6	6	6	7	7	7	7	7	7	5	5	5	5
	II: 50 °C / 72 °C				7	7	7	7	6	6	6	7	7	7	7	7	7	5	5	5	5
Hammer-drilling with standard drill bit or hollow drill bit and diamond-drilling (water filled hole)																					
Temperature range	I: 35 °C / 60 °C		$\tau_{Rk,cr}$	[N/mm <sup>2</sup> ]	6	7,5	6,5	6,5	6,5	6	6	6	6	6	6	6	6	5	5	5	5
	II: 50 °C / 72 °C				6	6,5	6,5	6	6	6	6	6	6	6	6	6	6	6	5	5	5
<b>Installation factors</b>																					
Dry or wet concrete		$\gamma_{inst}$	[-]																	1,0	
Water filled hole				1,2								1,4									
fischer injection system FIS EM Plus																					
<b>Performances</b> Characteristic values for combined pull-out and concrete failure for reinforcing bars; working life 50 years																		<b>Annex C 9</b> Appendix 30/ 39			

**Table C10.1:** Characteristic values for **combined pull-out** and concrete failure for **reinforcing bars** in hammer or diamond drilled holes; **uncracked or cracked concrete; working life 100 years**

Nominal diameter of the bar $\phi$		8	10	12	14	16	18	20	22	24	25	26	28	30	32	34	36	40	
<b>Combined pullout and concrete cone failure</b>																			
Calculation diameter d		[mm]	8	10	12	14	16	18	20	22	24	25	26	28	30	32	34	36	40
<b>Uncracked concrete</b>																			
<b>Characteristic bond resistance in uncracked concrete C20/25</b>																			
Hammer-drilling with standard drill bit or hollow drill bit (dry or wet concrete)																			
Temperature range	I: 35 °C / 60 °C	$\tau_{Rk,ucr}$	[N/mm <sup>2</sup> ]	16	15	15	14	14	13	13	13	12	12	12	12	11	11	11	11
	II: 50 °C / 72 °C			15	14	14	13	13	12	12	12	12	11	11	11	11	11	11	10
Diamond-drilling (dry or wet concrete)																			
Temperature range	I: 35 °C / 60 °C	$\tau_{Rk,ucr}$	[N/mm <sup>2</sup> ]	16	15	13	12	12	11	10	10	10	9	9	9	8	8	8	7
	II: 50 °C / 72 °C			15	14	12	11	11	10	10	9	9	9	8	8	8	8	7	7
<b>Installation factors</b>																			
Dry or wet concrete		$\gamma_{inst}$	[-]	1,0															
Working life 100 years	I: 35 °C / 60 °C	$\alpha_{100\ years}$	[-]	0,75	0,75	0,75	0,75	0,75	0,75	0,75	0,75	0,75	0,75	0,75	0,75	0,75	0,75	0,75	0,75
	II: 50 °C / 72 °C			0,55	0,60	0,60	0,65	0,65	0,65	0,65	0,65	0,65	0,65	0,65	0,65	0,65	0,65	0,65	0,65
<b>Cracked concrete</b>																			
<b>Characteristic bond resistance in cracked concrete C20/25</b>																			
Hammer-drilling with standard drill bit or hollow drill bit (dry or wet concrete)																			
Temperature range	I: 35 °C / 60 °C	$\tau_{Rk,cr}$	[N/mm <sup>2</sup> ]	7	7	8	8	8	8	8	8	8	8	8	8	8	8	8	8
	II: 50 °C / 72 °C			7	7	8	8	8	8	8	8	8	8	8	8	8	8	8	8
Diamond-drilling (dry or wet concrete)																			
Temperature range	I: 35 °C / 60 °C	$\tau_{Rk,cr}$	[N/mm <sup>2</sup> ]	7	7	7	7	6	6	6	7	7	7	7	7	5	5	5	5
	II: 50 °C / 72 °C			7	7	7	7	6	6	6	7	7	7	7	7	7	5	5	5
<b>Installation factors</b>																			
Dry or wet concrete		$\gamma_{inst}$	[-]	1,0															
Working life 100 years	I: 35 °C / 60 °C	$\alpha_{100\ years}$	[-]	0,60	0,85	0,80	0,65	0,65	0,65	0,65	0,65	0,65	0,65	0,65	0,65	0,65	0,65	0,65	0,65
	II: 50 °C / 72 °C			0,60	0,85	0,80	0,65	0,65	0,65	0,65	0,65	0,65	0,65	0,65	0,65	0,65	0,65	0,65	0,65

1) Calculation of characteristic bond resistance in uncracked concrete  $\tau_{Rk,100, ucr}$ :

$$\tau_{Rk,100, ucr} = \alpha_{100\ years} \cdot \tau_{Rk,ucr}$$

2) Calculation of characteristic bond resistance in cracked concrete  $\tau_{Rk,100, cr}$ :

$$\tau_{Rk,100, cr} = \alpha_{100\ years} \cdot \tau_{Rk,cr}$$

fischer injection system FIS EM Plus

**Performances**

Characteristic values for combined pull-out and concrete failure for reinforcing bars; working life 100 years

**Annex C 10**

Appendix 31/ 39



**Table C11.1:** Characteristic values for **combined pull-out** and concrete failure for **fischer rebar anchors FRA** in hammer or diamond drilled holes; **uncracked or cracked concrete; working life 50 years**

fischer rebar anchor FRA			M12	M16	M20	M24	
<b>Combined pullout and concrete cone failure</b>							
Calculation diameter	d	[mm]	12	16	20	25	
<b>Uncracked concrete</b>							
<b>Characteristic bond resistance in uncracked concrete C20/25</b>							
<u>Hammer-drilling with standard drill bit or hollow drill bit (dry or wet concrete)</u>							
Temperature range	I: 35 °C / 60 °C	$\tau_{Rk,ucr}$	[N/mm <sup>2</sup> ]	15	14	13	12
	II: 50 °C / 72 °C			14	13	12	12
<u>Hammer-drilling with standard drill bit or hollow drill bit (water filled hole)</u>							
Temperature range	I: 35 °C / 60 °C	$\tau_{Rk,ucr}$	[N/mm <sup>2</sup> ]	14	12	11	10
	II: 50 °C / 72 °C			13	12	11	9
<u>Diamond-drilling (dry or wet concrete as well as water filled hole)</u>							
Temperature range	I: 35 °C / 60 °C	$\tau_{Rk,ucr}$	[N/mm <sup>2</sup> ]	13	12	10	9
	II: 50 °C / 72 °C			12	11	10	9
<b>Installation factors</b>							
Dry or wet concrete		$\gamma_{inst}$	[-]	1,0			
Water filled hole				1,4			
<b>Cracked concrete</b>							
<b>Characteristic bond resistance in cracked concrete C20/25</b>							
<u>Hammer-drilling with standard drill bit or hollow drill bit and diamond-drilling (dry or wet concrete)</u>							
Temperature range	I: 35 °C / 60 °C	$\tau_{Rk,cr}$	[N/mm <sup>2</sup> ]	8	8	8	8
	II: 50 °C / 72 °C			8	8	8	8
<u>Hammer-drilling with standard drill bit or hollow drill bit and diamond-drilling (water filled hole)</u>							
Temperature range	I: 35 °C / 60 °C	$\tau_{Rk,cr}$	[N/mm <sup>2</sup> ]	7	6	6	6
	II: 50 °C / 72 °C			7	6	6	6
<b>Installation factors</b>							
Dry or wet concrete		$\gamma_{inst}$	[-]	1,0			
Water filled hole				1,2		1,4	
fischer injection system FIS EM Plus							
<b>Performances</b> Characteristic values for combined pull-out and concrete failure for fischer rebar anchors FRA; working life 50 years						<b>Annex C 11</b> Appendix 32/ 39	

**Table C12.1:** Characteristic values for **combined pull-out** and concrete failure for **fischer rebar anchors FRA** in hammer or diamond drilled holes; **uncracked or cracked concrete; working life 100 years**

fischer rebar anchor FRA			M12	M16	M20	M24	
<b>Combined pullout and concrete cone failure</b>							
Calculation diameter	d	[mm]	12	16	20	25	
<b>Uncracked concrete</b>							
<b>Characteristic bond resistance in uncracked concrete C20/25</b>							
<u>Hammer-drilling with standard drill bit or hollow drill bit (dry or wet concrete)</u>							
Temperature range	I: 35 °C / 60 °C	$\tau_{Rk,ucr}$	[N/mm <sup>2</sup> ]	15	14	13	12
	II: 50 °C / 72 °C			14	13	12	12
<u>Diamond-drilling (dry or wet concrete)</u>							
Temperature range	I: 35 °C / 60 °C	$\tau_{Rk,ucr}$	[N/mm <sup>2</sup> ]	13	12	10	9
	II: 50 °C / 72 °C			12	11	10	9
<b>Installation factors</b>							
Dry or wet concrete	$\gamma_{inst}$	[-]	1,0				
Working life 100 years	I: 35 °C / 60 °C	$\alpha_{100\text{ years}}$	[N/mm <sup>2</sup> ]	0,75	0,75	0,75	0,75
	II: 50 °C / 72 °C			0,60	0,65	0,65	0,65
<b>Cracked concrete</b>							
<b>Characteristic bond resistance in cracked concrete C20/25</b>							
<u>Hammer-drilling with standard drill bit or hollow drill bit and diamond-drilling (dry or wet concrete)</u>							
Temperature range	I: 35 °C / 60 °C	$\tau_{Rk,cr}$	[N/mm <sup>2</sup> ]	8	8	8	8
	II: 50 °C / 72 °C			8	8	8	8
<b>Installation factors</b>							
Dry or wet concrete	$\gamma_{inst}$	[-]	1,0				
Working life 100 years	I: 35 °C / 60 °C	$\alpha_{100\text{ years}}$	[-]	0,80	0,65	0,65	0,65
	II: 50 °C / 72 °C			0,80	0,65	0,65	0,65

1) **Calculation of characteristic bond resistance in uncracked concrete  $\tau_{Rk,100,ucr}$ :**

$$\tau_{Rk,100,ucr} = \alpha_{100\text{ years}} \cdot \tau_{Rk,ucr}$$

2) **Calculation of characteristic bond resistance in cracked concrete  $\tau_{Rk,100,cr}$ :**

$$\tau_{Rk,100,cr} = \alpha_{100\text{ years}} \cdot \tau_{Rk,cr}$$

fischer injection system FIS EM Plus

**Performances**

Characteristic values for pull-out and concrete failure for fischer rebar anchors FRA; working life 100 years

**Annex C 12**

Appendix 33/ 39

**Table C13.1: Displacements for anchor rods**

Anchor rod	M8	M10	M12	M14	M16	M20	M22	M24	M27	M30	
<b>Displacement-Factors for tension load<sup>1)</sup></b>											
<b>Uncracked or cracked concrete; Temperature range I, II</b>											
$\delta_{N0}$ -Factor	[mm/(N/mm <sup>2</sup> )]	0,07	0,08	0,09	0,09	0,10	0,11	0,11	0,12	0,12	0,13
$\delta_{N\infty}$ -Factor		0,11	0,12	0,13	0,14	0,15	0,16	0,17	0,18	0,19	0,19
<b>Displacement-Factors for shear load<sup>2)</sup></b>											
<b>Uncracked or cracked concrete; Temperature range I, II</b>											
$\delta_{V0}$ -Factor	[mm/kN]	0,18	0,15	0,12	0,10	0,09	0,07	0,07	0,06	0,05	0,05
$\delta_{V\infty}$ -Factor		0,27	0,22	0,18	0,16	0,14	0,11	0,10	0,09	0,08	0,07
1) Calculation of effective displacement: $\delta_{N0} = \delta_{N0}\text{-Factor} \cdot \tau_{Ed}$ $\delta_{N\infty} = \delta_{N\infty}\text{-Factor} \cdot \tau_{Ed}$ ( $\tau_{Ed}$ : Design value of the applied tensile stress)					2) Calculation of effective displacement: $\delta_{V0} = \delta_{V0}\text{-Factor} \cdot V_{Ed}$ $\delta_{V\infty} = \delta_{V\infty}\text{-Factor} \cdot V_{Ed}$ ( $V_{Ed}$ : Design value of the applied shear force)						

**Table C13.2: Displacements for fischer internal threaded anchors RG MI**

Internal threaded anchor RG MI	M8	M10	M12	M16	M20	
<b>Displacement-Factors for tension load<sup>1)</sup></b>						
<b>Uncracked or cracked concrete; Temperature range I, II</b>						
$\delta_{N0}$ -Factor	[mm/(N/mm <sup>2</sup> )]	0,09	0,10	0,10	0,11	0,13
$\delta_{N\infty}$ -Factor		0,13	0,15	0,16	0,17	0,19
<b>Displacement-Factors for shear load<sup>2)</sup></b>						
<b>Uncracked or cracked concrete; Temperature range I, II</b>						
$\delta_{V0}$ -Factor	[mm/kN]	0,12	0,09	0,08	0,07	0,05
$\delta_{V\infty}$ -Factor		0,18	0,14	0,12	0,10	0,08
1) Calculation of effective displacement: $\delta_{N0} = \delta_{N0}\text{-Factor} \cdot \tau_{Ed}$ $\delta_{N\infty} = \delta_{N\infty}\text{-Factor} \cdot \tau_{Ed}$ ( $\tau_{Ed}$ : Design value of the applied tensile stress)			2) Calculation of effective displacement: $\delta_{V0} = \delta_{V0}\text{-Factor} \cdot V_{Ed}$ $\delta_{V\infty} = \delta_{V\infty}\text{-Factor} \cdot V_{Ed}$ ( $V_{Ed}$ : Design value of the applied shear force)			

**Table C14.1: Displacements for reinforcing bars**

Nominal diameter of the bar $\phi$		8	10	12	14	16	18	20	22	24	25	26	28	30	32	34	36	40
<b>Displacement-Factors for tension load<sup>1)</sup></b>																		
<b>Uncracked or cracked concrete; Temperature range I, II</b>																		
$\delta_{N0}$ -Factor	[mm/(N/mm <sup>2</sup> )]	0,07	0,08	0,09	0,09	0,10	0,10	0,11	0,11	0,12	0,12	0,12	0,13	0,13	0,13	0,14	0,14	0,15
$\delta_{N\infty}$ -Factor		0,11	0,12	0,13	0,14	0,15	0,16	0,16	0,17	0,18	0,18	0,18	0,19	0,19	0,20	0,20	0,21	0,22
<b>Displacement-Factors for shear load<sup>2)</sup></b>																		
<b>Uncracked or cracked concrete; Temperature range I, II</b>																		
$\delta_{V0}$ -Factor	[mm/kN]	0,18	0,15	0,12	0,10	0,09	0,08	0,07	0,07	0,06	0,06	0,06	0,05	0,05	0,05	0,04	0,04	0,04
$\delta_{V\infty}$ -Factor		0,27	0,22	0,18	0,16	0,14	0,12	0,11	0,10	0,09	0,09	0,08	0,08	0,07	0,07	0,06	0,06	0,05
1) Calculation of effective displacement: $\delta_{N0} = \delta_{N0}\text{-Factor} \cdot \tau_{Ed}$ $\delta_{N\infty} = \delta_{N\infty}\text{-Factor} \cdot \tau_{Ed}$ ( $\tau_{Ed}$ : Design value of the applied tensile stress)									2) Calculation of effective displacement: $\delta_{V0} = \delta_{V0}\text{-Factor} \cdot V_{Ed}$ $\delta_{V\infty} = \delta_{V\infty}\text{-Factor} \cdot V_{Ed}$ ( $V_{Ed}$ : Design value of the applied shear force)									

**Table C14.2: Displacements for fischer rebar anchors FRA**

fischer rebar anchor FRA	M12	M16	M20	M24
<b>Displacement-Factors for tension load<sup>1)</sup></b>				
<b>Uncracked or cracked concrete; Temperature range I, II</b>				
$\delta_{N0}$ -Factor	0,09		0,10	0,12
$\delta_{N\infty}$ -Factor	0,13		0,15	0,18
<b>Displacement-Factors for shear load<sup>2)</sup></b>				
<b>Uncracked or cracked concrete; Temperature range I, II</b>				
$\delta_{V0}$ -Factor	0,12		0,09	0,06
$\delta_{V\infty}$ -Factor	0,18		0,14	0,09
1) Calculation of effective displacement: $\delta_{N0} = \delta_{N0}\text{-Factor} \cdot \tau_{Ed}$ $\delta_{N\infty} = \delta_{N\infty}\text{-Factor} \cdot \tau_{Ed}$ ( $\tau_{Ed}$ : Design value of the applied tensile stress)		2) Calculation of effective displacement: $\delta_{V0} = \delta_{V0}\text{-Factor} \cdot V_{Ed}$ $\delta_{V\infty} = \delta_{V\infty}\text{-Factor} \cdot V_{Ed}$ ( $V_{Ed}$ : Design value of the applied shear force)		

fischer injection system FIS EM Plus

**Performance**  
 Displacements for reinforcing bars and fischer rebar anchors FRA

**Table C15.1: Characteristic values for steel failure under tension / shear load of fischer anchor rods and standard threaded rods under seismic action performance category C1 or C2**

Anchor rod / standard threaded rod		M10	M12	M14	M16	M20	M22	M24	M27	M30				
<b>Bearing capacity under tension load, steel failure<sup>1)</sup></b>														
<b>fischer anchor rods and standard threaded rods, performance category C1<sup>2)</sup></b>														
Characteristic resistance $N_{Rk,s,C1}$	Steel zinc plated	Property class	5.8	[kN]	29(27)	43	58	79	123	152	177	230	281	
			8.8		47(43)	68	92	126	196	243	282	368	449	
	Stainless steel R and high corrosion resistant steel HCR		50		29	43	58	79	123	152	177	230	281	
			70		41	59	81	110	172	212	247	322	393	
		80		47	68	92	126	196	243	282	368	449		
	<b>fischer anchor rods and standard threaded rods, performance category C2<sup>2)</sup></b>													
	Characteristic resistance $N_{Rk,s,C2}$	Steel zinc plated	Property class	5.8	[-]	- <sup>4)</sup>	39	- <sup>4)</sup>	72	108	- <sup>4)</sup>	177	- <sup>4)</sup>	- <sup>4)</sup>
				8.8		- <sup>4)</sup>	61	- <sup>4)</sup>	116	173	- <sup>4)</sup>	282	- <sup>4)</sup>	- <sup>4)</sup>
Stainless steel R and high corrosion resistant steel HCR		50			- <sup>4)</sup>	39	- <sup>4)</sup>	72	108	- <sup>4)</sup>	177	- <sup>4)</sup>	- <sup>4)</sup>	
		70			- <sup>4)</sup>	53	- <sup>4)</sup>	101	152	- <sup>4)</sup>	247	- <sup>4)</sup>	- <sup>4)</sup>	
		80		- <sup>4)</sup>	61	- <sup>4)</sup>	116	173	- <sup>4)</sup>	282	- <sup>4)</sup>	- <sup>4)</sup>		
<b>Bearing capacity under shear load, steel failure without lever arm<sup>1)</sup></b>														
<b>fischer anchor rods, performance category C1<sup>2)</sup></b>														
Characteristic resistance $V_{Rk,s,C1}$		Steel zinc plated	Property class	5.8	[kN]	17(16)	25	34	47	74	91	106	138	168
	8.8				23(21)	34	46	63	98	122	141	184	225	
	Stainless steel R and high corrosion resistant steel HCR	50			15	21	29	39	61	76	89	115	141	
		70			20	30	40	55	86	107	124	161	197	
		80		23	34	46	63	98	122	141	184	225		
	<b>Standard threaded rods, performance category C1<sup>2)</sup></b>													
	Characteristic resistance $V_{Rk,s,C1}$	Steel zinc plated	Property class	5.8	[kN]	12(11)	17	24	33	52	64	74	97	118
				8.8		16(14)	24	32	44	69	85	99	129	158
Stainless steel R and high corrosion resistant steel HCR		50			11	15	20	27	43	53	62	81	99	
		70			14	21	28	39	60	75	87	113	138	
		80		16	24	32	44	69	85	99	129	158		
<b>fischer anchor rods and standard threaded rods, performance category C2</b>														
Characteristic resistance $V_{Rk,s,C2}$		Steel zinc plated	Property class	5.8	[-]	- <sup>4)</sup>	14	- <sup>4)</sup>	27	43	- <sup>4)</sup>	62	- <sup>4)</sup>	- <sup>4)</sup>
				8.8		- <sup>4)</sup>	22	- <sup>4)</sup>	44	69	- <sup>4)</sup>	99	- <sup>4)</sup>	- <sup>4)</sup>
	Stainless steel R and high corrosion resistant steel HCR	50			- <sup>4)</sup>	14	- <sup>4)</sup>	27	43	- <sup>4)</sup>	62	- <sup>4)</sup>	- <sup>4)</sup>	
		70			- <sup>4)</sup>	20	- <sup>4)</sup>	39	60	- <sup>4)</sup>	87	- <sup>4)</sup>	- <sup>4)</sup>	
		80		- <sup>4)</sup>	22	- <sup>4)</sup>	44	69	- <sup>4)</sup>	99	- <sup>4)</sup>	- <sup>4)</sup>		
	Factor for the annular gap	$\alpha_{gap}$	[-]	0,5 (1,0) <sup>3)</sup>										

<sup>1)</sup> Partial factors for performance category C1 or C2 see table C1.1;

for fischer anchor rods FIS A / RGM the factor for steel ductility is 1,0

<sup>2)</sup> Values in brackets are valid for undersized threaded rods with smaller stress area  $A_s$  for hot dip galvanised standard threaded rods according to EN ISO 10684:2004+AC:2009.

<sup>3)</sup> Values in brackets are valid for filled annular gaps between the anchor rod and the through-hole in the attachment. It is necessary to use the fischer filling disc according to Annex A 1

<sup>4)</sup> No performance assessed

fischer injection system FIS EM Plus

**Performances**

Characteristic values for steel failure under tension / shear load for fischer anchor rods and standard threaded rods under seismic action (performance category C1 / C2)

**Annex C 15**

Appendix 36/ 39

**Table C16.1:** Characteristic values for **steel failure** under tension / shear load for **reinforcing bars (B500B)** under seismic action performance category **C1**

Nominal diameter of the bar	$\phi$	10	12	14	16	18	20	22	24	25	26	28	30	32	
<b>Bearing capacity under tension load, steel failure<sup>1)</sup></b>															
<b>Reinforcing bar B500B acc. to DIN 488-2:2009-08, performance category C1</b>															
Characteristic resistance	$N_{Rk,s,C1}$	[kN]	44	63	85	111	140	173	209	249	270	292	339	389	443
<b>Bearing capacity under shear load, steel failure without lever arm<sup>1)</sup></b>															
<b>Reinforcing bar B500B acc. to DIN 488-2:2009-08, performance category C1</b>															
Characteristic resistance	$V_{Rk,s,C1}$	[kN]	15	22	30	39	49	61	74	88	95	102	119	137	155

<sup>1)</sup> Partial factors for performance category C1 see table C16.2

**Table C16.2:** **Partial factors** for **fischer anchor rods, standard threaded rods** and **reinforcing bars (B500B)** under seismic action performance category **C1 or C2**

Anchor rod / standard threaded rod		M10	M12	M14	M16	M20	M22	M24	M27	M30	M32			
Nominal diameter of the bar	$\phi$	10	12	14	16	18	20	22	24	25	26	28	30	32
<b>Tension load, steel failure<sup>1)</sup></b>														
Partial factor $\gamma_{Ms,N}$	Steel zinc plated	Property class	5.8	[-]	1,50									
			8.8		1,50									
	Stainless steel R and high corrosion resistant steel HCR	50	2,86											
		70	1,50 <sup>2)</sup> / 1,87											
		80	1,60											
	Reinforcing bar	B500B	1,40											
<b>Shear load, steel failure<sup>1)</sup></b>														
Partial factor $\gamma_{Ms,V}$	Steel zinc plated	Property class	5.8	[-]	1,25									
			8.8		1,25									
	Stainless steel R and high corrosion resistant steel HCR	50	2,38											
		70	1,25 <sup>2)</sup> / 1,56											
		80	1,33											
	Reinforcing bar	B500B	1,50											

<sup>1)</sup> In absence of other national regulations

<sup>2)</sup> Only admissible for high corrosion resistant steel HCR, with  $f_{yk} / f_{uk} \geq 0,8$  and  $A_5 > 12 \%$  (e.g. fischer anchor rods)

fischer injection system FIS EM Plus

**Performances**

Characteristic values for steel failure under tension/shear load for reinforcing bars under seismic action (performance category C1); partial factors (perform. category C1 / C2)

**Annex C 16**

Appendix 37/ 39

**Table C17.1:** Characteristic values for **combined pull-out** and concrete failure for **fischer anchor rods** and **standard threaded rods** in hammer drilled holes under seismic action performance category **C1**; **working life 50 and 100 years**

Anchor rod / standard threaded rod		M10	M12	M14	M16	M20	M22	M24	M27	M30
<b>Characteristic bond resistance, combined pullout and concrete cone failure</b>										
<b>Hammer-drilling with standard drill bit or hollow drill bit (dry or wet concrete)</b>										
Temperature range	I: 35 °C / 60 °C	$\tau_{RK,C1}$ [N/mm <sup>2</sup> ]	7,0	7,0	6,7	6,0	5,7	6,7	6,7	6,7
	II: 50 °C / 72 °C		7,0	7,0	6,7	5,7	5,7	6,7	6,7	6,7
<b>Hammer-drilling with standard drill bit or hollow drill bit (water filled hole)</b>										
Temperature range	I: 35 °C / 60 °C	$\tau_{RK,C1}$ [N/mm <sup>2</sup> ]	7,5	7,5	6,5	5,7	5,7	5,7	5,7	5,7
	II: 50 °C / 72 °C		6,8	6,8	6,5	5,7	5,7	5,7	5,7	5,7
<b>Installation factors</b>										
Dry or wet concrete	$\gamma_{inst}$	[-]	1,0							
Water filled hole			1,2 <sup>1)</sup>				1,4 <sup>1)</sup>			

<sup>1)</sup> Not permitted in combination with working life 100 years

**Table C17.2:** Characteristic values for **combined pull-out** and concrete failure for **reinforcing bars** in hammer drilled holes under seismic action performance category **C1**; **working life 50 and 100 years**

Nominal diameter of the bar $\phi$		10	12	14	16	18	20	22	24	25	26	28	30	32
<b>Characteristic bond resistance, combined pullout and concrete cone failure</b>														
<b>Hammer-drilling with standard drill bit or hollow drill bit (dry or wet concrete)</b>														
Temperature range	I: 35 °C / 60 °C	$\tau_{RK,C1}$ [N/mm <sup>2</sup> ]	7,0	7,0	6,7	5,7	5,7	5,7	6,7	6,7	6,7	6,7	6,7	4,8
	II: 50 °C / 72 °C		7,0	7,0	6,7	5,7	5,7	5,7	6,7	6,7	6,7	6,7	6,7	6,7
<b>Hammer-drilling with standard drill bit or hollow drill bit (water filled hole)</b>														
Temperature range	I: 35 °C / 60 °C	$\tau_{RK,C1}$ [N/mm <sup>2</sup> ]	7,5	6,5	6,5	5,7	5,7	5,7	5,7	5,7	5,7	5,7	5,7	4,8
	II: 50 °C / 72 °C		6,5	6,5	5,8	5,8	5,7	5,7	5,7	5,7	5,7	5,7	5,7	4,8
<b>Installation factors</b>														
Dry or wet concrete	$\gamma_{inst}$	[-]	1,0											
Water filled hole			1,2 <sup>1)</sup>						1,4 <sup>1)</sup>					

<sup>1)</sup> Not permitted in combination with working life 100 years

fischer injection system FIS EM Plus

**Performances**

Characteristic values for combined pull-out and concrete failure under seismic action (C1 for fischer anchor rods, stand. thread. rods and reinf. bars; working life 50 and 100 years)

**Annex C 17**

Appendix 38/ 39

**Table C18.1:** Characteristic values for **combined pull-out** and concrete failure for **fischer anchor rods** and **standard threaded rods** in hammer drilled holes under seismic action performance category **C2**; **working life 50 and 100 years**

Anchor rod / standard threaded rod		M12	M16	M20	M24	
<b>Characteristic bond resistance, combined pullout and concrete cone failure</b>						
<b>Hammer-drilling with standard drill bit or hollow drill bit (dry or wet concrete)</b>						
Tem- perature range	I: 35 °C / 60 °C	$\tau_{Rk,C2}$ [N/mm <sup>2</sup> ]	3,5	5,8	5,0	3,1
	II: 50 °C / 72 °C		3,3	5,5	4,7	2,9
<b>Hammer-drilling with standard drill bit or hollow drill bit (water filled hole)</b>						
Tem- perature range	I: 35 °C / 60 °C	$\tau_{Rk,C2}$ [N/mm <sup>2</sup> ]	3,5	5,8	5,0	3,1
	II: 50 °C / 72 °C		3,3	5,5	4,7	2,9
<b>Installation factors</b>						
Dry or wet concrete		$\gamma_{inst}$ [-]	1,0			
Water filled hole			1,2 <sup>1)</sup>	1,4 <sup>1)</sup>		

<sup>1)</sup> Not permitted in combination with working life 100 years

**Displacement-Factors for tension load<sup>1)</sup>**

$\delta_{N,C2}$ (DLS)-Factor	[mm/(N/mm <sup>2</sup> )]	0,09	0,10	0,11	0,12
$\delta_{N,C2}$ (ULS)-Factor		0,15	0,17	0,17	0,18

**Displacement-Factors for shear load<sup>2)</sup>**

$\delta_{V,C2}$ (DLS)-Factor	[mm/kN]	0,18	0,10	0,07	0,06
$\delta_{V,C2}$ (ULS)-Factor		0,25	0,14	0,11	0,09

<sup>1)</sup> Calculation of effective displacement:

$$\delta_{N,C2} (DLS) = \delta_{N,C2} (DLS)\text{-Factor} \cdot \tau_{Ed}$$

$$\delta_{N,C2} (ULS) = \delta_{N,C2} (ULS)\text{-Factor} \cdot \tau_{Ed}$$

( $\tau_{Ed}$ : Design value of the applied tensile stress)

<sup>2)</sup> Calculation of effective displacement:

$$\delta_{V,C2} (DLS) = \delta_{V,C2} (DLS)\text{-Factor} \cdot V_{Ed}$$

$$\delta_{V,C2} (ULS) = \delta_{V,C2} (ULS)\text{-Factor} \cdot V_{Ed}$$

( $V_{Ed}$ : Design value of the applied shear force)

fischer injection system FIS EM Plus

**Performances**

Characteristic values for combined pull-out and concrete failure under seismic action (C2) for fischer anchor rods and standard threaded rods; working life 50 and 100 years

**Annex C 18**

Appendix 39/ 39