

VYHLÁSENIE O PARAMETROCH

DoP 0325

pre fischer TermoZ PN 8 (Plastové kotvy pre použitie v betóne a murive)

SK

1. <u>Jedinečný identifikačný kód typu výrobku:</u>	DoP 0325	
2. <u>Zamýšľané použitie/použitia:</u>	Natáková plastová kotva pre ukotvenie vonkajších tepelnoizolačných, kompozitných systémov (ETICS) s omietkou do betónu a muriva, Pozri prílohu, najmä prílohy B1- B3.	
3. <u>Výrobca:</u>	fischerwerke GmbH & Co. KG, Klaus-Fischer-Str. 1, 72178 Waldachtal, Nemecko	
4. <u>Splnomocnený zástupca:</u>	–	
5. <u>Systém(-y) posudzovania a overovania nemennosti parametrov:</u>	2+	
6. <u>Európsky hodnotiaci dokument:</u> Európske technické posúdenie: Orgán technického posudzovania: Notifikovaný(-é) subjekt(-y):	EAD 330196-01-0604, Edition 10/2017 ETA-09/0171; 2022-10-18 DIBt- Deutsches Institut für Bautechnik 2873 TU Darmstadt	
7. <u>Deklarované parametre:</u> Bezpečnosť pri používaní (BWR 4) Charakteristická únosnosť:	Charakteristická odolnosť pri zaťažení ťahom: Minimálna vzdialenosť od okraja: Minimálna osová vzdialenosť:	Príloha C1 Príloha B2 Príloha B2
Posuny:	Zaťaženie v ťahu s čiastočným súčiniteľom: Posuny:	Príloha C2 Príloha C2
Tuhosť dosky:	Priemer tanierika: Odolnosť tanierika: Tuhosť tanierika:	Príloha C2 Príloha C2 Príloha C2
Úspora energie a zadržanie tepla (BWR 6) Tepelná priepustnosť:	Bodová tepelná priepustnosť kotvy: Hrúbka izolačnej vrstvy ETICS:	Príloha C2 Príloha C2
8. <u>Vhodná technická dokumentácia a/alebo špecifická technická dokumentácia:</u>	–	

Uvedené parametre výrobku sú v zhode so súborom deklarovateľných parametrov. Toto vyhlásenie o parametroch sa v súlade s nariadením (EÚ) č. 305/2011 vydáva na výhradnú zodpovednosť uvedeného výrobcu.

Podpísal(-a) za a v mene výrobcu:



Dr.-Ing. Oliver Geibig, konateľ oddelenia Produkt management & vývoj
Tumlingen, 2022-11-14



Jürgen Grün, konateľ oddelenia Chemická výroba & kvalita

Toto vyhlásenie o vlastnostiach bolo vyhotovené v rôznych jazykoch. V prípade, že dôjde k rozdielnemu výkladu má anglická verzia vždy prednosť.

Príloha obsahuje dobrovoľné a doplňujúce informácie v anglickom jazyku. Tieto vychádzajú zo zákonom stanovených požiadaviek (jazykovo neutrálnych).

Specific part

1 Technical description of the product

The fischer nailed-in anchor TermoZ PN 8 consists of a plastic sleeve made of polypropylene, a plate and an accompanying specific nail made of glass fibre reinforced polyamide.

The anchor may in addition be combined with the anchor plates DT 90, DT 110 and DT 140.

The Product description is given in Annex A.

2 Specification of the intended use in accordance with the applicable European Assessment Document

The performances given in Section 3 are only valid if the anchor is used in compliance with the specifications and conditions given in Annex B.

The verification and assessment methods on which this European Technical Assessment is based lead to the assumption of a working life of the anchor of at least 25 years. The indications given on the working life cannot be interpreted as a guarantee given by the producer, but are to be regarded only as a means for choosing the right products in relation to the expected economically reasonable working life of the works.

3 Performance of the product and references to the methods used for its assessment

3.1 Safety and accessibility in use (BWR 4)

Essential characteristic	Performance
Characteristic load bearing capacity <ul style="list-style-type: none">- Characteristic resistance under tension load- Minimum edge distance and spacing	See Annex C 1 See Annex B 2
Displacements	See Annex C 2
Plate stiffness	See Annex C 2

3.2 Energy economy and heat retention (BWR 6)

Essential characteristic	Performance
Point thermal transmittance	See Annex C 2

4 Assessment and verification of constancy of performance (AVCP) system applied, with reference to its legal base

In accordance with EAD No. 330196-01-0604, the applicable European legal act is: [97/463/EC].

The system to be applied is: 2+

TermoZ PN 8

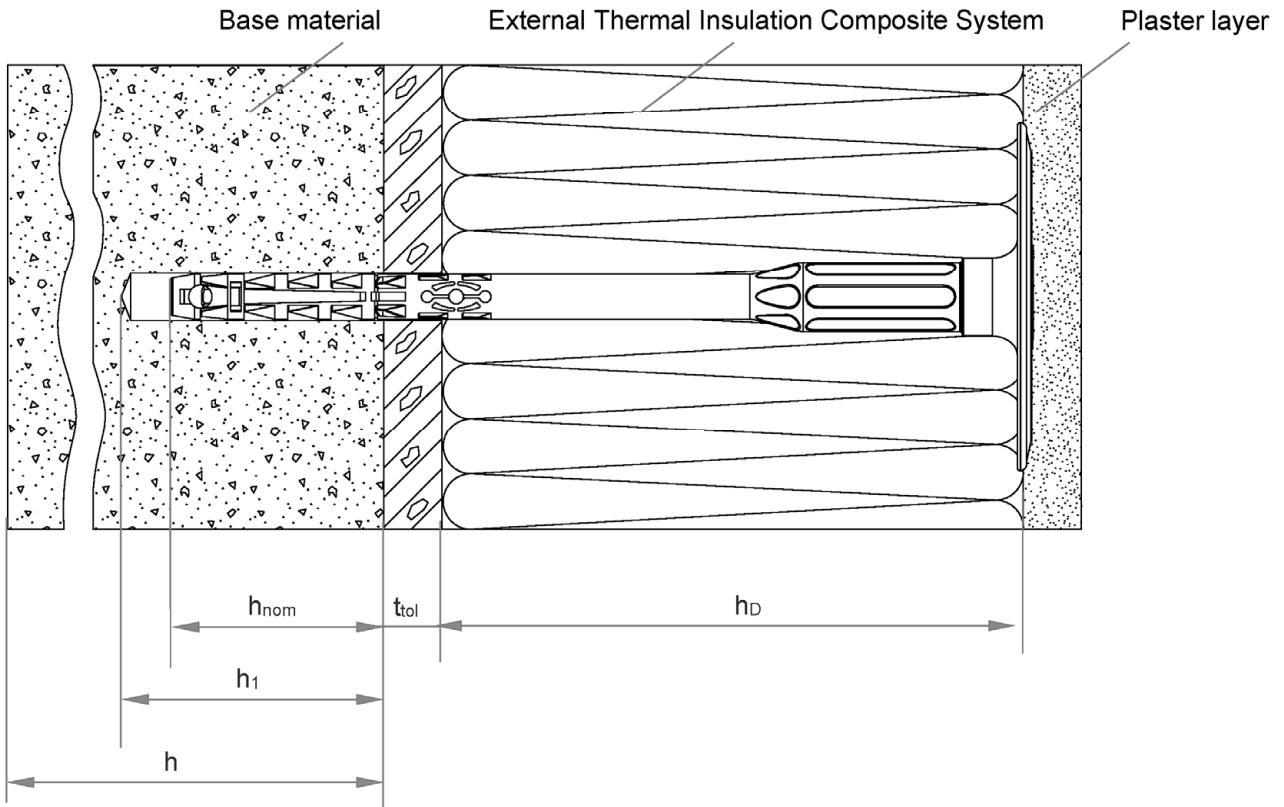

Legend

- h_{nom} = Overall plastic anchor embedment depth in the base material
- h_1 = Depth of drilled hole to deepest point
- h = Thickness of member (wall)
- h_D = Thickness of insulation material
- t_{tol} = Thickness of equalising layer and / or non-load bearing coating

Figure not to scale

fischer TermoZ PN 8

Product description
Installed anchor

Annex A 1

Appendix 2 / 9

TermoZ PN 8

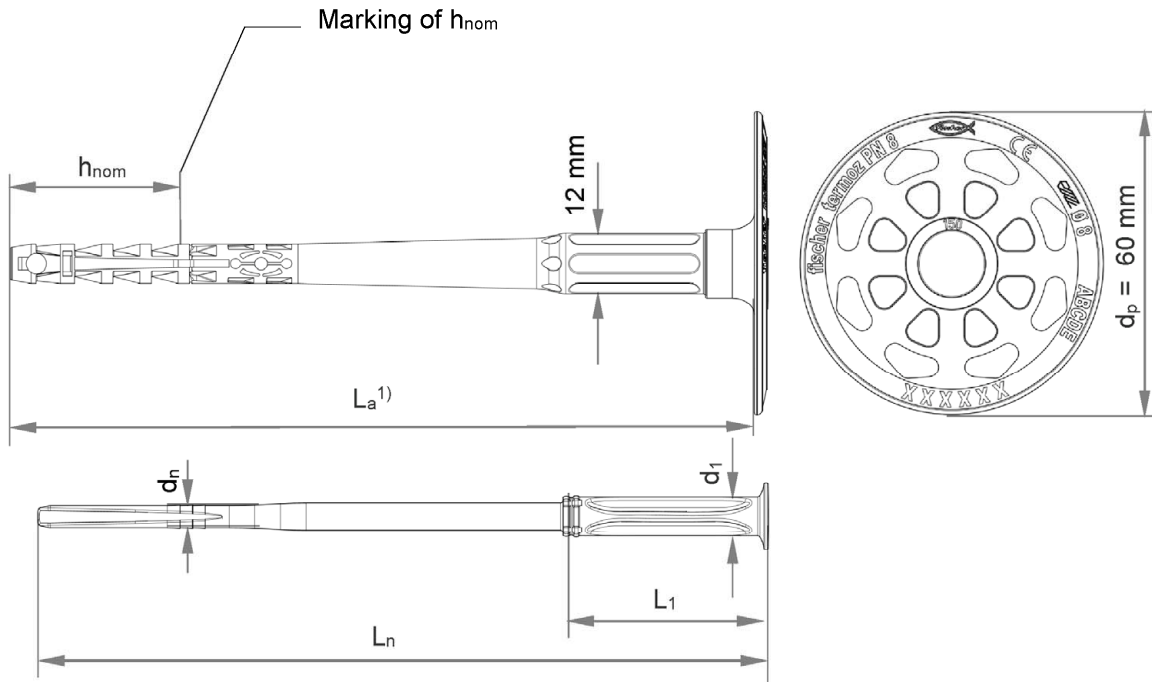

1) Various length of the anchors are possible.

TermoZ PN 8 :

$L_{a \min} \geq 110 \text{ mm}$; $L_{a \max} \leq 230 \text{ mm}$

$L_a = \text{length of accompanying specific nail } L_n + 5 \text{ mm}$

Table A2.1: Dimensions

Anchor typep	Anchor sleeve		Accompanying specific plastic nail		
	d_d [mm]	h_{nom} [mm]	d_n [mm]	L_1 [mm]	d_1 [mm]
TermoZ PN 8	8	35/55 ²⁾	4,4	40	8

2) Only for base material group „D“ and „E“.

Determination of max. thickness of insulation:

$$\max. h_D = L_a - h_{nom} - t_{tol}$$

e.g. for TermoZ PN 8x150:

$L_a = 148 \text{ mm}$, $h_{nom} = 35 \text{ mm}$, $t_{tol} = 10 \text{ mm}$

$$\max h_D = 148 - 35 - 10 = 103 \text{ mm}$$

recommended $h_D = 100 \text{ mm}$

Figures not to scale

fischer TermoZ PN 8

Product description
Dimensions

Annex A 2

Appendix 3 / 9

Table A3.1: Material

Designation	Material
Anchor sleeve	PP, colour: grey
Specific plastic nail	PA6 GF, colour: nature
Anchor plate / Slip-on plate	PA6, GF colour: grey, orange, red, green, yellow, blue, mocca-latte, black

Drawing of the slip-on-plate (e.g. DT 140)

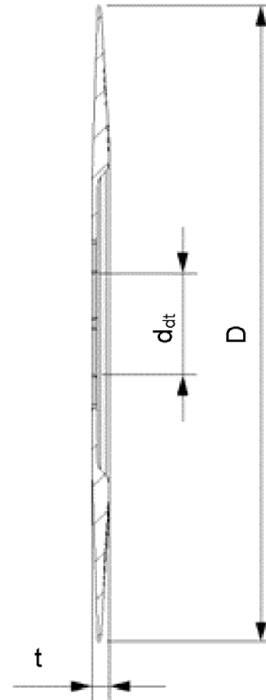
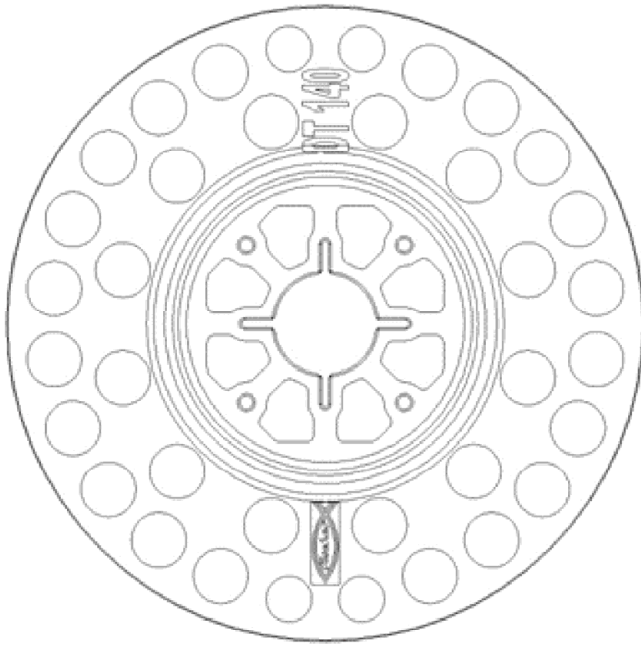

Table A3.2: Slip-on plate, dimensions and material

Slip-on plate	D [mm]	d _{dt} [mm]	t [mm]
DT 90 / 110 / 140	90 / 110 / 140	22,5	3,9

Figures not to scale

fischer TermoZ PN 8

Product description

Material

Dimensions of slip-on plate for the combination with TermoZ PN 8

Annex A 3

Appendix 4 / 9

Specifications of intended use

Anchorage subject to:

- The anchor may only be used for transmission of wind suction loads and shall not be used for the transmission of dead loads of the external thermal insulation composite system (ETICS).

Base materials:

- Compacted normal weight concrete without fibres, strength classes \geq C12/15 (base material group "A"), in accordance with EN 206, see Annex C1.
- Solid brick masonry (base material group "B") as per EN 771-1, EN 771-2 or EN 771-3, see Annex C1.
- Hollow brick masonry (base material group "C"), as per EN 771-1, EN 771-2 or EN 771-3, see Annex C1.
- Prefabricated reinforced components of lightweight aggregate concrete with open structure (base material group "D") as per EN 1520, see Annex C1.
- Unreinforced autoclaved aerated concrete (base material group "E") as per EN 771-4 and reinforced autoclaved aerated concrete (base material group "E") as per EN 12602, see Annex C1.
- For other comparable base materials of the base material group "A", "B", "C", "D" and "E" the characteristic resistance of the anchor may be determined by job site tests in accordance with EOTA Technical Report TR 051.

Temperature Range:

- 0 °C to + 40 °C (max. short term temperature + 40 °C and max. long term temperature + 24 °C) of the base material.

Design:

- The anchorages are designed under the responsibility of an engineer experienced in anchorages and masonry work with the partial safety factors for material related resistances $\gamma_M = 2,0$ and for action loads $\gamma_F = 1,5$ in absence of other national regulations.
- Verifiable calculation notes and drawings are prepared taking account of the loads to be anchored. The position of the anchors is indicated on the design drawings.
- Fasteners are only to be used for multiple fixings of external thermal insulation composite system.

Installation:

- Drilling method according to Annex C1.
- Anchor installation carried out by appropriately qualified personnel and under the supervision of the person responsible for technical matters on the site.
- Installation temperature from 0 °C to + 40 °C.
- Exposure to UV due to solar radiation of the anchor not protected by rendering \leq 6 weeks.

fischer TermoZ PN 8

Intended use
Specifications

Annex B 1

Appendix 5 / 9

Table B2.1: Installation parameters for base material groups “A” concrete, “B” solid bricks, “C” hollow or perforated bricks, “D” lightweight aggregate concrete and “E” autoclaved aerated concrete

Anchor type		TermoZ PN 8
Nominal drill hole diameter	$d_0 =$ [mm]	8
Cutting diameter of drill bit	$d_{cut} \leq$ [mm]	8,45
Depth of drilled hole to deepest point	$h_1 \geq$ [mm]	45/65 ¹⁾
Overall plastic anchor embedment depth in the base material	$h_{nom} \geq$ [mm]	35/55 ¹⁾

¹⁾ Only for base material group “D” and “E”.

Table B2.2: Minimum thickness of member, edge distances and spacing in all regulated base material groups

Anchor type		TermoZ PN 8
Minimum thickness of member	$h_{min} =$ [mm]	100
Minimum spacing	$s_{min} =$ [mm]	100
Minimum edge distance	$c_{min} =$ [mm]	100

Scheme of edge distances and spacing
for base material group “A”, concrete, group “B” solid bricks, group “C” hollow or perforated masonry, group “D” lightweight aggregate concrete, group “E” autoclaved aerated concrete

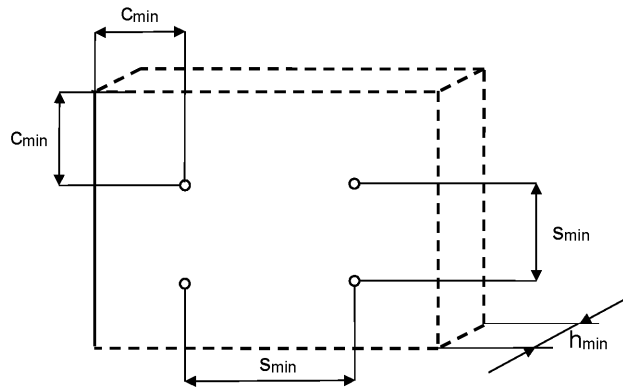

Figure not to scale

fischer TermoZ PN 8

Intended use

Installation parameters depending on the base material groups
Minimum thickness of member, edge distances and spacings

Annex B 2

Appendix 6 / 9

Installation instruction

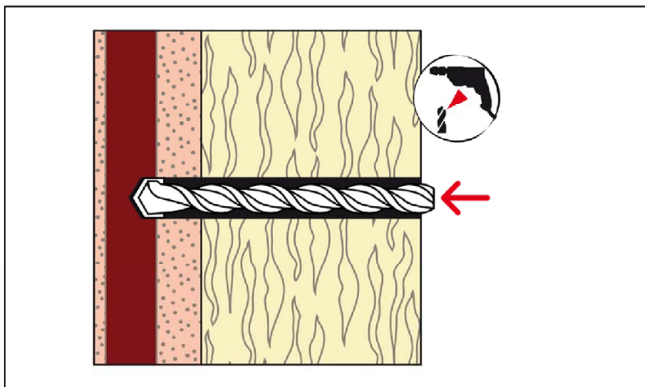

1. Drill hole by corresponding drilling method defined for each stone according to Table C1.1 and drill hole diameter d_0 and depth h_1 according to Table B2.1.

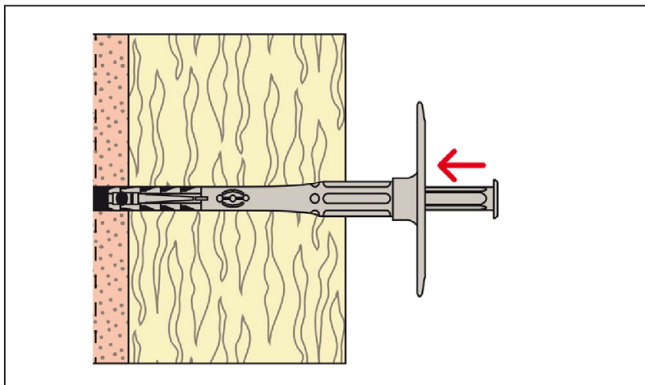

2. Insert anchor manually.

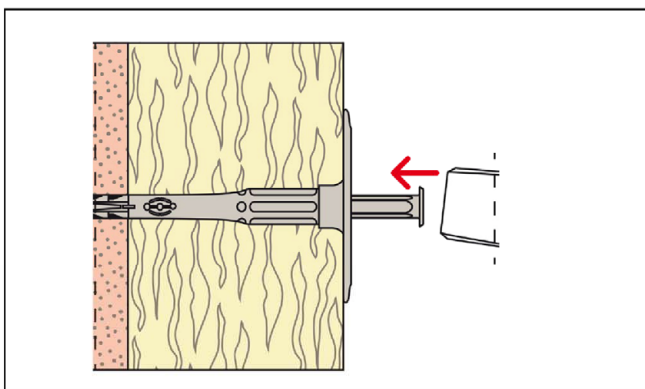

3. Set anchor by hammer blows.

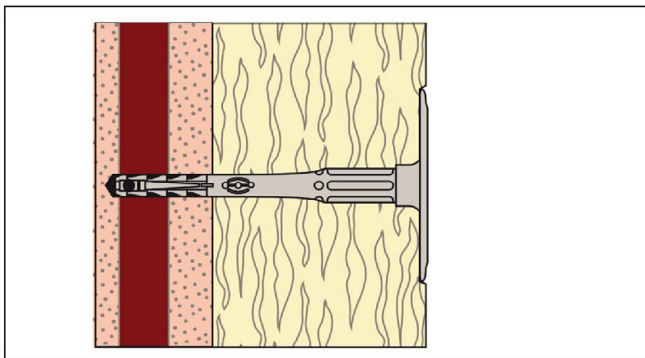

4. Correctly installed anchor.

fischer TermoZ PN 8

Intended use
Installation instruction

Annex B 3

Appendix 7 / 9

Table C1.1: Characteristic resistance N_{Rk} to tension loads for single anchor TermoZ PN 8

Base material	Group	Bulk density ρ [kg/dm ³]	Mean compressive strength / minimum compressive strength single brick as per EN 771 ⁴⁾ [N/mm ²]	Remarks	Drilling method ¹⁾	Characteristic resistance to tension loads N_{Rk} [kN]
Concrete, C12/15 - C50/60 as per EN 206	A	-	-	-	H	0,50
Solid Clay bricks, Mz as per EN 771-1	B ²⁾	≥ 2,0	15/12	-	H	0,60
Calcium silicate solid bricks, KS as per EN 771-2	B ²⁾	≥ 1,8	15/12	-	H	0,60
Vertically perforated clay, HLz bricks as per EN 771-1	C ³⁾	≥ 1,0	15/12	Exterior web thickness ≥ 12 mm.	R	0,40
Hollow calcium silicate brick, KSL as per EN 771-2	C ³⁾	≥ 1,4	15/12	Exterior web thickness ≥ 23 mm.	H	0,40
Lightweight concrete hollow blocks, Hbl as per EN 771-3	C ³⁾	≥ 1,2	12,5/10	Exterior web thickness ≥ 38 mm.	H	0,50
Lightweight aggregate concrete, LAC as per EN 1520	D ³⁾	≥ 0,9	5/4	Minimum thickness of brick h = 100 mm or minimum exterior web thickness t = 50 mm.	H	0,30
			7,5/6			0,40
Unreinforced autoclaved aerated concrete members, AAC as per EN 771-4 Reinforced autoclaved aerated concrete blocks, AAC as per EN 12602	E	≥ 0,5	5/4	-	R	0,30
		≥ 0,6	7,5/6			0,40

¹⁾ H = Hammer drilling, R = Rotary drilling.

²⁾ Vertically perforation ≤ 15%; cross section reduced by perforation vertically to the resting area.

³⁾ Vertically perforation > 15 % and ≤ 50 %, cross section reduced by perforation vertically to the resting area.

⁴⁾ The compressive strength of the single brick must not be less than 80% of the mean compressive strength.

fischer TermoZ PN 8

Performances

Characteristic resistance to tension load for single anchor

Annex C 1

Appendix 8 / 9

Table C2.1: Point thermal transmittance according to EOTA Technical Report TR 025

Anchor type	Thickness of insulation material h_D [mm]	Point thermal transmittance χ [W/K]
TermoZ PN 8	60 - 180	0,000

Table C2.2: Plate stiffness according to EOTA Technical Report TR 026

Anchor type	Maximum size of anchor plate d_p [mm]	Load resistance of anchor plate [kN]	Plate stiffness c [kN/mm]
TermoZ PN 8	60	1,7	0,6

Table C2.3: Displacements TermoZ PN 8

Base material	Mean compressive strength / minimum compressive strength single brick as per EN 771 ¹⁾ [N/mm ²]	Tension load N [kN]	Displacements $\Delta\delta_N$ [mm]
Concrete, C12/15 – C50/60 as per EN 206	-	0,15	0,20
Clay brick, Mz as per EN 771-1	15/12	0,20	0,20
Calcium silicate solid bricks, KS as per EN 771-2	15/12	0,20	0,30
Vertically perforated clay brick, Hlz as per EN 771-1	15/12	0,15	0,40
Hollow calcium silicate brick, KSL as per EN 771-2	15/12	0,15	0,20
Hollow brick lightweight concrete, Hbl as per EN 771-3	12,5/10	0,15	0,20
Lightweight aggregate concrete, LAC as per EN 1520	5/4	0,10	0,20
	7,5/6	0,13	
Unreinforced autoclaved aerated concrete members, AAC as per EN 771-4 and reinforced autoclaved aerated concrete members, AAC as per EN 12602	5/4	0,10	0,10
	7,5/6	0,13	0,20

¹⁾ The compressive strength of the single brick must not be less than 80% of the mean compressive strength.

fischer TermoZ PN 8

Performances

Point thermal transmittance and plate stiffness
Displacements

Annex C 2

Appendix 9 / 9