

DECLARAȚIA DE PERFORMANȚĂ

DoP 0404

pentru sistem de injecție fischer FIS VL (Mortar pentru conexiuni de armare postinstalate)

RO

- Cod unic de identificare al produsului-tip: **DoP 0404**
- Utilizare (utilizări) preconizată (preconizate): **Sistem pentru conectarea armăturilor post-instalate cu mortar pentru utilizare în beton, Consultați suplimentul, în special anexele B1-B10.**
- Fabricant: **fischerwerke GmbH & Co. KG, Klaus-Fischer-Str. 1, 72178 Waldachtal, Germany**
- Reprezentant autorizat: **-**
- Sistemul (sistemele) de evaluare și de verificare a constanței performanței: **1**
- Documentul de evaluare european: **EAD 330087-01-0601 Edition 06/2021**
Evaluarea tehnică europeană: **ETA-15/0539; 2025-11-20**
Organismul de evaluare tehnică: **DIBt- Deutsches Institut für Bautechnik**
Organism (organisme) notificat(e): **2873 TU Darmstadt**
- Performanța (performanțe) declarată (declarate):
Rezistență mecanică și stabilitate (BWR 1)
Rezistența caracteristică sub încărcări statice și cvasistatice:
Aderența pentru armături post-instalate: Anexa C1
Factor de reducere: Anexa C1
Factor de amplificare pentru lungimea minimă de ancorare: Anexa C1
Rezistența caracteristică la cedarea oțelului pentru armături supuse la întindere: NPD

Rezistența caracteristică sub încărcare seismică:
Aderența sub încărcare seismică, Factor de eficiență al aderenței sub încărcare seismică: NPD
Grosimea minimă a stratului de acoperire cu beton sub încărcare seismică: NPD

Siguranța în caz de incendiu (BWR 2)
Reacție la foc: Clasa (A1)

Rezistența la incendiu:
Aderența la temperatură ridicată pentru armătura post-instalată evaluată pentru 50 de ani: NPD
Aderența la temperatură ridicată pentru armătura post-instalată evaluată pentru 100 de ani: NPD
Rezistența caracteristică la cedarea oțelului pentru armături supuse la întindere în condiții de expunere la foc: NPD
- Documentație tehnică adecvată și/sau documentație tehnică specifică: **-**

Performanța produsului identificat mai sus este în conformitate cu setul de performanțe declarate. Această declarație de performanță este eliberată în conformitate cu Regulamentul (UE) nr. 305/2011, pe răspunderea exclusivă a fabricantului identificat mai sus.

Semnată pentru și în numele fabricantului de către:



Dr. Ronald Mihala, Director Executiv Departament Business & Inginerie
Tumlingen, 2025-12-08



Dieter Pfaff, Șeful Federației Internaționale de Producție și Managementul Calității

Această declarație de performanță a fost întocmită în mai multe limbi. În cazul unei divergențe de interpretare, versiunea în limba engleză prevalează întotdeauna.

Suplimentul include informații voluntare și complementare în limba engleză, în afara cerințelor legale (specificate neutru din punct de vedere al limbii).

Translation guidance Essential Characteristics and Performance Parameters for Annexes

Ghid de traducere a caracteristicilor esențiale și a parametrilor de performanță pentru anexe

Mechanical resistance and stability (BWR 1)	
Rezistență mecanică și stabilitate (BWR 1)	
Characteristic resistance under static and quasi-static loading: Rezistența caracteristică sub încărcări statice și cvasistatice:	
1 Bond strength of post-installed rebar: Aderența pentru armături post-instalate:	$f_{bd,PIR}$ [N/mm ²], $f_{bd,PIR,100y}$ [N/mm ²]
2 Bond efficiency factor: Factor de reducere:	k_b [-], $k_{b,100y}$ [-]
3 Amplification factor for minimum anchorage length: Factor de amplificare pentru lungimea minimă de ancorare:	α_{lb} [-], $\alpha_{lb,100y}$ [-]
4 Characteristic resistance to steel failure for rebar tension anchors: Rezistența caracteristică la cedarea oțelului pentru armături supuse la întindere:	$N_{Rk,s}$ [kN]
Characteristic resistance under seismic loading: Rezistența caracteristică sub încărcare seismică:	
5 Bond strength under seismic loading, Seismic bond efficiency factor: Aderența sub încărcare seismică, Factor de eficiență al aderenței sub încărcare seismică:	$f_{bd,PIR,seis}$ [N/mm ²], $k_{b,seis}$ [-], $f_{bd,PIR,seis,100y}$ [N/mm ²], $k_{b,seis,100y}$ [-]
6 Minimum concrete cover under seismic loading: Grosimea minimă a stratului de acoperire cu beton sub încărcare seismică:	$c_{min,seis}$ [mm]
Safety in case of fire (BWR 2)	
Siguranța în caz de incendiu (BWR 2)	
7 Reaction to fire: Reacție la foc:	Class
Resistance to fire: Rezistența la incendiu:	
8 Bond strength at increased temperature for post-installed rebar assessed for 50 years: Aderența la temperatură ridicată pentru armătura post-instalată evaluată pentru 50 de ani:	$f_{bd,fi}(\theta)$ [N/mm ²], $k_{fi}(\theta)$ [-], θ_{max} [°C]
9 Bond strength at increased temperature for post-installed rebar assessed for 100 years: Aderența la temperatură ridicată pentru armătura post-instalată evaluată pentru 100 de ani:	$f_{bd,fi,100y}(\theta)$ [N/mm ²], $k_{fi,100y}(\theta)$ [-], θ_{max} [°C]
10 Characteristic resistance to steel failure for rebar tension anchors under fire exposure: Rezistența caracteristică la cedarea oțelului pentru armături supuse la întindere în condiții de expunere la foc:	$N_{Rk,s,fi}$ [kN]

Specific Part

1 Technical description of the product

The subject of this European Technical Assessment is the post-installed connection, by anchoring or overlap connection joint, of reinforcing bars (rebars) in existing structures made of normal weight concrete, using the "Rebar connection with injection system FIS VL" in accordance with the regulations for reinforced concrete construction.

Reinforcing bars made of steel with a diameter ϕ from 10 to 25 mm according to Annex A and injection mortar FIS VL are used for rebar connections. The rebar is placed into a drilled hole filled with injection mortar and is anchored via the bond between rebar, injection mortar and concrete.

The product description is given in Annex A.

2 Specification of the intended use in accordance with the applicable European assessment Document

The performances given in Section 3 are only valid if the rebar connection is used in compliance with the specifications and conditions given in Annex B.

The verifications and assessment methods on which this European Technical Assessment is based lead to the assumption of a working life of the rebar connections of at least 50 years. The indications given on the working life cannot be interpreted as a guarantee given by the producer, but are to be regarded only as a means for choosing the right products in relation to the expected economically reasonable working life of the works.

3 Performance of the product and references to the methods used for its assessment

3.1 Mechanical resistance and stability (BWR 1)

Essential characteristic	Performance
Characteristic resistance under static and quasi-static loading	See Annex C1
Characteristic resistance under seismic loading	No performance assessed

3.2 Safety in case of fire (BWR 2)

Essential characteristic	Performance
Reaction to fire	Class A1
Resistance to fire	No performance assessed

4 Assessment and verification of constancy of performance (AVCP) system applied, with reference to its legal base

In accordance with European Assessment Document EAD No. 330087-01-0601, the applicable European legal act is: [96/582/EC].

The system to be applied is: 1

Installation conditions and application examples reinforcing bars, part 1

Figure A1.1:

Overlap joint with existing reinforcement for rebar connections of slabs and beams

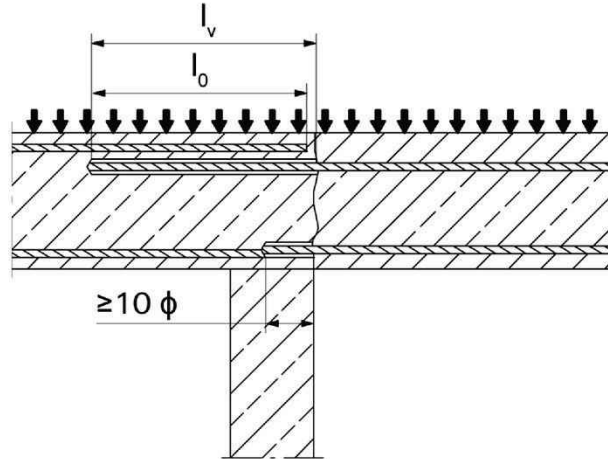

Figure A1.2:

Overlap joint with existing reinforcement at a foundation of a column or wall where the rebar is stressed

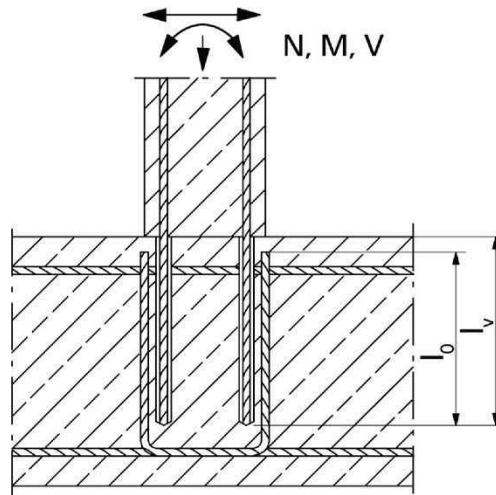
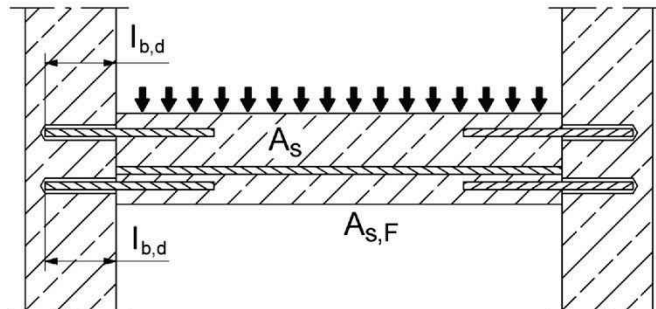

Figure A1.3:

End anchoring of slabs or beams (e.g. designed as simply supported)



Figures not to scale

Rebar connection with injection system FIS VL

Product description

Installation conditions and application examples reinforcing bars, part 1

Annex A1

Appendix 2 / 16

Installation conditions and application examples reinforcing bars, part 2

Figure A2.1:

Rebar connection for stressed primarily in compression

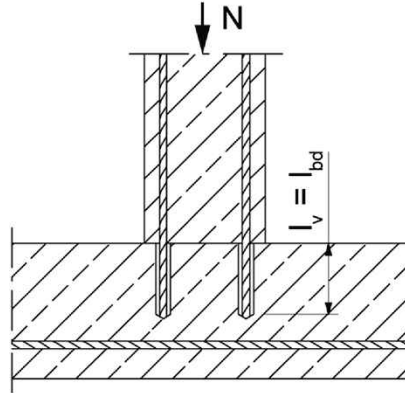
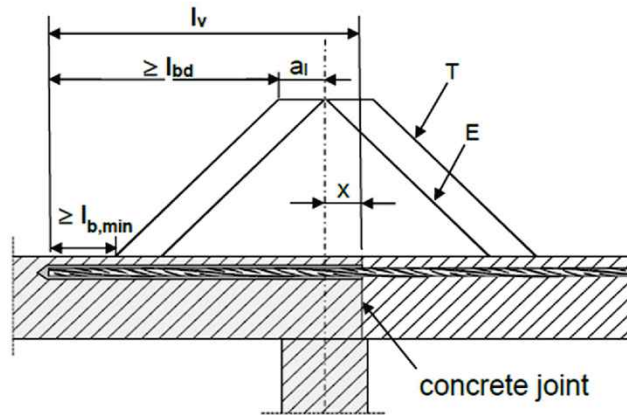

Figure A2.2:

Anchoring of reinforcement to cover the enveloped line of acting tensile force in the bending member



(only post-installed rebar is plotted)

Key to Figure

- T Acting tensile force
- E Envelope of $M_{ed} / z + N_{ed}$ (see EN 1992-1-1:2011)
- x Distance between the theoretical point of support and concrete joint

Note to **figure A1.1 to A1.3** and **figure A2.1 to A2.2**

In the figures no traverse reinforcement is plotted, the traverse reinforcement as required by EN 1992-1-1:2011 shall be present.

The shear transfer between old and new concrete shall be designed according to EN 1992-1-1:2011. Preparation of joints according to **Annex B3** of this document

Figures not to scale

Rebar connection with injection system FIS VL

Product description

Installation conditions and application examples reinforcing bars, part 2

Annex A2

Appendix 3 / 16

Overview system components

Injection cartridge (shuttle cartridge) with sealing cap; Sizes: 360 ml, 825 ml

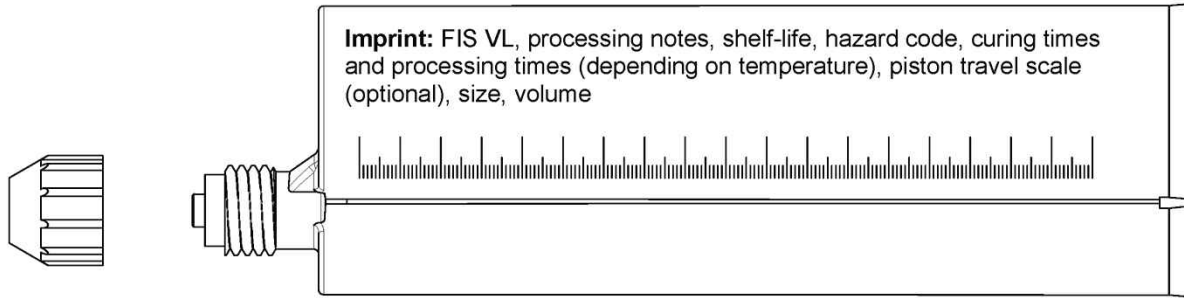

Injection cartridge (coaxial cartridge) with sealing cap; Sizes: 300 ml, 380 ml, 400 ml, 410 ml

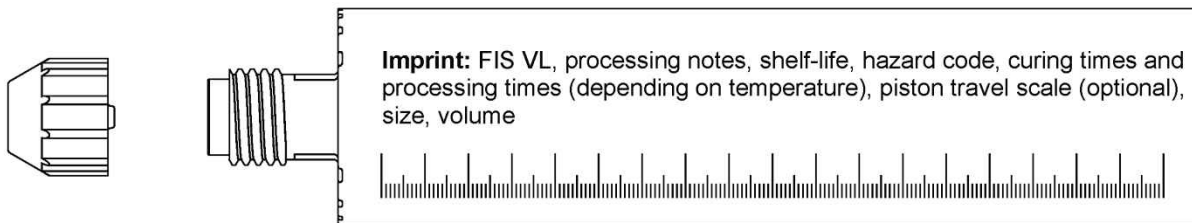

Static mixer FIS MR Plus for injection cartridges up to 410 ml

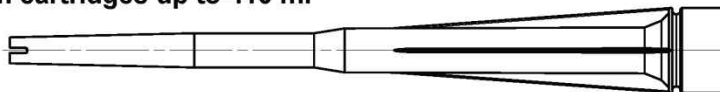

Static mixer FIS JMR for injection cartridges 825 ml

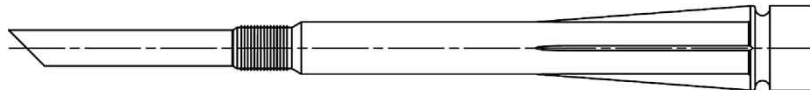

**Injection adapter and extension tube Ø 9 for static mixer FIS MR Plus;
Injection adapter and extension tube Ø 9 or Ø 15 for static mixer FIS JMR**

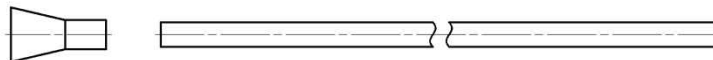

Reinforcing bar (rebar) Sizes: $\phi 10$, $\phi 12$, $\phi 14$, $\phi 16$, $\phi 20$, $\phi 25$



Blow out pump AB G



Compressed-air cleaning tool AB P with fischer compressed-air nozzle

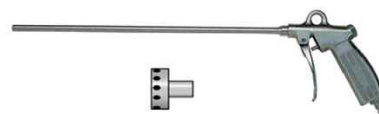

Figures not to scale

Rebar connection with injection system FIS VL

Product description

Overview system components; Injection mortar, static mixer, injection adapter, reinforcing bar

Annex A3

Appendix 4 / 16

Properties of reinforcing bars (rebar)

Figure A4.1:



- The minimum value of related rib area $f_{R,min}$ according to EN 1992-1-1:2011
- The maximum outer rebar diameter over the ribs shall be:
 - The nominal diameter of the bar with rib $\phi + 2 \cdot h$ ($h \leq 0,07 \cdot \phi$)
 - (ϕ : Nominal diameter of the bar; h_{rib} = rib height of the bar)

Table A4.1: Installation conditions for rebars

Nominal diameter of the bar		ϕ	10 ¹⁾		12 ¹⁾		14	16	20	25 ¹⁾	
Nominal drill hole diameter	d_0	[mm]	12	14	14	16	18	20	25	30	35
Drill hole depth	h_0		$h_0 = l_v$								
Effective embedment depth	l_v		acc. to static calculation								
Minimum thickness of concrete member	h_{min}		$l_v + 30$ (≥ 100)			$l_v + 2d_0$					

¹⁾ Both drill hole diameters can be used.

Table A4.2: Materials of rebars

Designation	Reinforcing bar (rebar)
Reinforcing bar EN 1992-1-1:2011, Annex C	Bars and de-coiled rods class B or C with f_{yk} and k according to NDP or NCI of EN 1992-1-1/NA $f_{uk} = f_{tk} = k \cdot f_{yk}$

Figures not to scale



Rebar connection with injection system FIS VL

Product description
Properties and materials of reinforcing bars (rebar)

Annex A4
Appendix 5 / 16

Specifications of intended use part 1

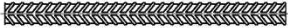
Table B1.1: Overview use and performance categories

Anchorages subject to		FIS VL with ...	
		Reinforcing bar 	
Hammer drilling or compressed air drilling with standard drill bit 		all sizes	
Hammer drilling with hollow drill bit  (fischer "FHD" & "FHD II", Heller "Duster Expert", Bosch "Speed Clean", Hilti "TE-CD, TE-YD")		Nominal drill bit diameter (d_0) 12 mm to 35 mm	
Use category I1	dry or wet concrete	all sizes	
Characteristic resistance under static and quasi static loading, in	uncracked concrete	all sizes	Tables: C1.1 C1.2 C1.3
	cracked concrete		
Characteristic resistance under seismic loading		_1)	
Installation direction		D3 (downward and horizontal and upwards (e.g. overhead))	
Installation temperature		$T_{i,min} = 0\text{ °C}$ to $T_{i,max} = +40\text{ °C}$	
Service temperature	Temperature range	-40 °C to +80 °C	(max. short term temperature +80 °C; max long term temperature +50 °C)
Resistance to fire		_1)	

¹⁾ No performance assessed

Rebar connection with injection system FIS VL

Intended use
Specifications part 1

Annex B1
Appendix 6 / 16

Specifications of intended use part 2

Anchorage subject to:

- Static and quasi-static loading: reinforcing bar (rebar) size 10 mm to 25 mm;

Base materials:

- Compacted reinforced or unreinforced normal weight concrete without fibres according to EN 206:2013+A2:2021
- Concrete strength classes C20/25 to C35/45 according to EN 206:2013+A2:2021
- Maximum chloride content of 0,40 % (CL 0.40) related to the cement content according to EN 206:2013+A2:2021
- Non-carbonated concrete

Note: In case of a carbonated surface of the existing concrete structure the carbonated layer shall be removed in the area of the post-installed rebar connection with a diameter of $\phi + 60$ mm prior to the installation of the new rebar. The depth of concrete to be removed shall correspond to at least the minimum concrete cover in accordance with EN 1992-1-1:2011. The foregoing may be neglected if building components are new and not carbonated and if building components are in dry conditions.

Design:

- The structural design according to EN 1992-1-1:2011, EN 1992-1-2:2011 and Annex B3 and B4 are conducted under responsibility of a designer experienced in the field of anchorages and concrete works.
- Verifiable calculation notes and drawings are prepared taking account of the forces to be transmitted.
- The actual position of the reinforcement in the existing structure shall be determined on the basis of the construction documentation and taken into account when designing.

Installation:

- The installation of post-installed rebar shall be done only by suitable trained installer and under Supervision on site; the conditions under which an installer may be considered as suitable trained and the conditions for Supervision on site are up to the Member States in which the installation is done.
- Check the position of the existing rebars (if the position of existing rebars is not known, it shall be determined using a rebar detector suitable for this purpose as well as on the basis of the construction documentation and then marked on the building component for the overlap joint).

Rebar connection with injection system FIS VL

Intended use
Specifications part 2

Annex B2
Appendix 7 / 16

General construction rules for post-installed rebars

Figure B3.1:

- Only tension forces in the axis of the rebar may be transmitted.
- The transfer of shear forces between new concrete and existing structure shall be designed additionally according to EN 1992-1-1:2011.
- The joints for concreting must be roughened to at least such an extent that aggregate protrude.

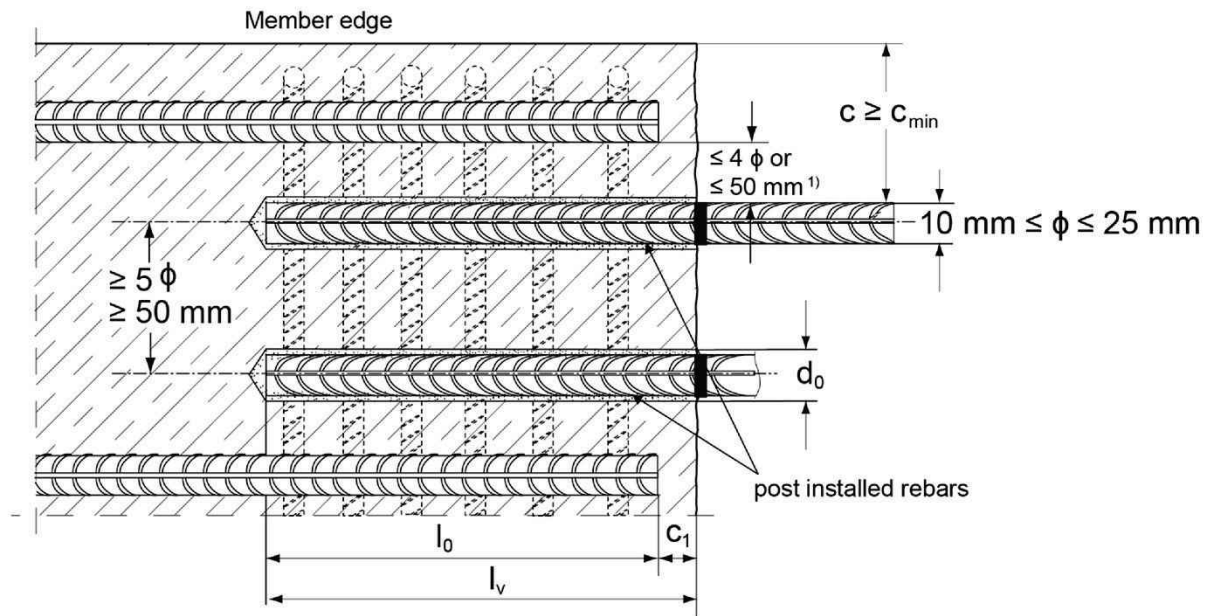

¹⁾ If the clear distance between lapped bars exceeds 4ϕ or 50 mm then the lap length shall be increased by the difference between the clear bar distance and the smaller 4ϕ or 50 mm.

- c concrete cover of post-installed rebar
- c₁ concrete cover at end-face of existing rebar
- c_{min} minimum concrete cover according to **Table B4.1** and to EN 1992-1-1:2011, Section 4.4.1.2
- φ nominal diameter of reinforcing bar
- l₀ lap length, according to EN 1992-1-1:2011 for static loading
- l_v effective embedment depth, $\geq l_0 + c_1$
- d₀ nominal drill bit diameter, see **Annex B5**

Figures not to scale

Rebar connection with injection system FIS VL

Intended use
General construction rules for post-installed rebars

Annex B3
Appendix 8 / 16

Table B4.1: Minimum concrete cover $c_{min}^{1)}$ depending of the drilling method and the drilling tolerance

Drilling method	nominal diameter of reinforcing bar ϕ [mm]	Minimum concrete cover c_{min}	
		Without drilling aid [mm]	With drilling aid [mm]
Hammer drilling with standard drill bit or hollow drill bit	< 25	$30 \text{ mm} + 0,06 l_v \geq 2 \phi$	$30 \text{ mm} + 0,02 l_v \geq 2 \phi$
	≥ 25	$40 \text{ mm} + 0,06 l_v \geq 2 \phi$	$40 \text{ mm} + 0,02 l_v \geq 2 \phi$
Compressed air drilling	< 25	$50 \text{ mm} + 0,08 l_v$	$50 \text{ mm} + 0,02 l_v$
	≥ 25	$60 \text{ mm} + 0,08 l_v \geq 2 \phi$	$60 \text{ mm} + 0,02 l_v \geq 2 \phi$

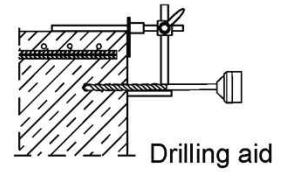

¹⁾ See Annex B3, figure B3.1

Note: The minimum concrete cover as specified in EN 1992-1-1:2011 must be observed.

Table B4.2: Dispensers and cartridge sizes corresponding to maximum embedment depth $l_{v,max}$

reinforcing bars (rebar) ϕ [mm]	Manual dispenser	Accu and pneumatic dispenser (small)	Accu and pneumatic dispenser (large)
	Cartridge size		
	< 500 ml $l_{v,max} / l_{e,ges,max}$ [mm]		> 500 ml $l_{v,max} / l_{e,ges,max}$ [mm]
10	1000	1000	1800
12		1200	
14		1500	
16		1300	
20	700	1000	
25			

Table B4.3: Conditions for use static mixer without an extension tube

Nominal drill hole diameter d_0	[mm]	10	12	14	16	18	20	24	25	30	35
		Drill hole depth h_0 by FIS MR Plus using FIS JMR		≤ 90	≤ 120	≤ 140	≤ 150	≤ 160	≤ 190	≤ 210	
		-	-	≤ 90	≤ 160	≤ 180	≤ 190	≤ 220		≤ 250	

Figures not to scale

Rebar connection with injection system FIS VL

Intended use
Minimum concrete cover;
dispenser and cartridge sizes corresponding to maximum embedment depth

Annex B4
Appendix 9 / 16

Table B5.1: Working times t_{work} and curing times t_{cure}

Temperature in the anchorage base [°C]	Maximum working time ¹⁾ t_{work} FIS VL	Minimum curing time ²⁾ t_{cure} FIS VL
0 to 5 ³⁾	13 min	3 h
> 5 to 10 ³⁾	9 min	90 min
> 10 to 20	5 min	60 min
> 20 to 30	4 min	45 min
> 30 to 40 ⁴⁾	2 min	35 min

¹⁾ Maximum time from the beginning of the injection to rebar setting and positioning.

²⁾ For wet concrete the curing time must be doubled.

³⁾ If the temperature in the concrete falls below 10 °C the cartridge must be warmed up to +15 °C.

⁴⁾ If the temperature in the concrete exceeds 30 °C the cartridge must be cooled down to +15 °C up to 20 °C.

Table B5.2: Installation tools for drilling and cleaning the bore hole and injection of the mortar

reinforcing bars (rebar) ϕ [mm]	Drilling and cleaning				Injection	
	Nominal drill bit diameter d_0 [mm]	Diameter of cutting edge d_{cut} [mm]	Steel brush diameter d_b [mm]	Diameter of fischer compressed air nozzle [mm]	Diameter of extension tube [mm]	Injection adapter [colour]
10 ¹⁾	12	≤ 12,50	12,5	11	9	nature
	14	≤ 14,50	15			blue
12 ¹⁾	14	≤ 14,50	15	15	9 or 15	red
	16	≤ 16,50	17			yellow
14	18	≤ 18,50	19	19	9 or 15	green
16	20	≤ 20,55	21,5			black
20	25	≤ 25,55	26,5	28	9 or 15	grey
25 ¹⁾	30	≤ 30,55	32			brown
		35	≤ 35,70	37		

¹⁾ Both drill bit diameters can be used.

Rebar connection with injection system FIS VL

Intended use

Working times and curing times;
Installation tools for drilling and cleaning the bore hole and injection of the mortar

Annex B5

Appendix 10 / 16

Safety regulations



Review the Safety Data Sheet (SDS) before use for proper and safe handling!
Wear well-fitting protective goggles and protective gloves when working with mortar FIS VL.
Important: Observe the instructions for use provided with each cartridge.

Installation instruction part 1; Installation with FIS VL

Hole drilling

Note: Before drilling, remove carbonized concrete; clean contact areas (see **Annex B2**)
In case of aborted drill holes the drill hole shall be filled with mortar.

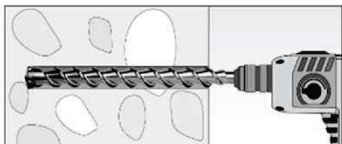
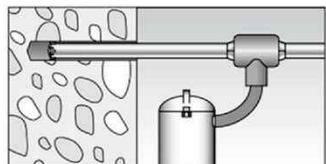
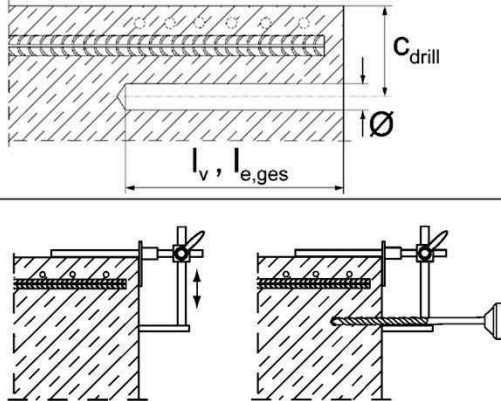
1a	<p>Hammer drilling or compressed air drilling</p> 	<p>Drill the hole to the required embedment depth using a hammer drill with carbide drill bit set in rotation hammer mode or a pneumatic drill. Drill bit sizes see Table B5.2.</p>
1b	<p>Hammer drilling with hollow drill bit</p> 	<p>Drill the hole to the required embedment depth using a hammer drill with hollow drill bit in rotation hammer mode. Dust extraction conditions see drill hole cleaning Annex B7. Drill bit sizes see Table B5.2.</p>
2		<p>Measure and control concrete cover c ($c_{drill} = c + \varnothing / 2$) Drill parallel to surface edge and to existing rebar. Where applicable use drilling aid.</p> <p>For holes $l_v > 20$ cm use drilling aid. Three different options can be considered: A) drilling aid B) Slat or spirit level C) Visual check</p> <p>Minimum concrete cover c_{min} see Table B4.1.</p>

Rebar connection with injection system FIS VL

Intended use

Safety regulations; Installation instruction part 1, hole drilling

Annex B6

Appendix 11 / 16

Installation instruction part 2; Installation with FIS VL

Drill hole cleaning

Hammer or compressed air drilling

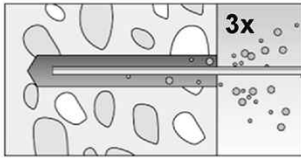

Clean the drill hole:
For $d_0 < 18$ mm and depths l_v resp.
 $l_{e,ges} \leq 12 \cdot \phi$
blow out the hole three times by hand.

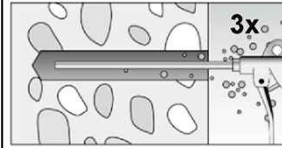

For $d_0 > 18$ mm and depths l_v resp.
 $l_{e,ges} > 12 \cdot \phi$ blow out the hole three times with oil-free compressed air ($p \geq 6$ bar). Use suitable compressed-air nozzle (see **Table B5.2**).

3a

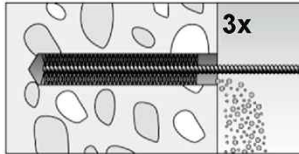

Brush drill hole three times; for drill hole diameters $d_0 \geq 30$ mm attach brush to a power tool and brush hole with a speed of max. 550 revolutions per minute. For deep holes a brush extension is mandatory. Use suitable brushes (see **Table B5.2**).

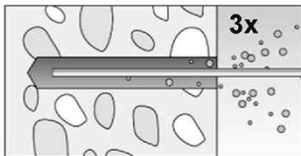

Clean the drill hole:
For $d_0 < 18$ mm and depths l_v resp.
 $l_{e,ges} \leq 12 \cdot \phi$
blow out the hole three times by hand.

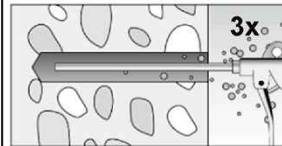

For $d_0 > 18$ mm and depths l_v resp.
 $l_{e,ges} > 12 \cdot \phi$ blow out the hole three times with oil-free compressed air ($p \geq 6$ bar) Use suitable compressed-air nozzle (see **Table B5.2**).

Hammer drilling with hollow drill bit



3b

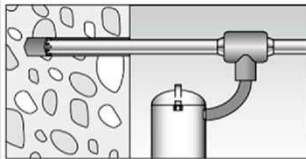

Use a suitable dust extraction system, e. g. fischer FVC 35 M or a comparable dust extraction system with equivalent performance data.
Drill the hole with hollow drill bit. The dust extraction system has to extract the drill dust nonstop during the drilling process and must be adjusted to maximum power.
No further drill hole cleaning necessary.

Rebar connection with injection system FIS VL

Intended use
Installation instruction part 2, drill hole cleaning

Annex B7
Appendix 12 / 16

Installation instruction part 3; Installation with FIS VL

reinforcing bars (rebar) and cartridge preparation

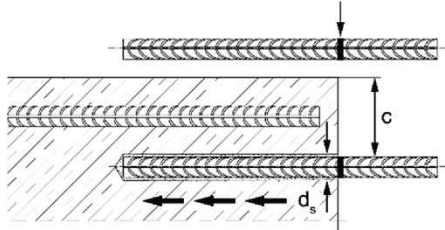
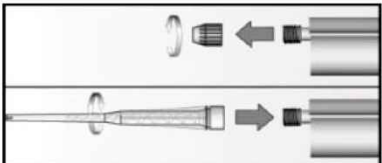
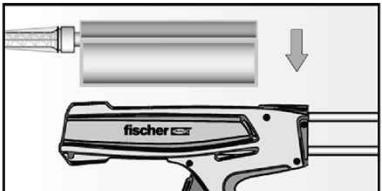
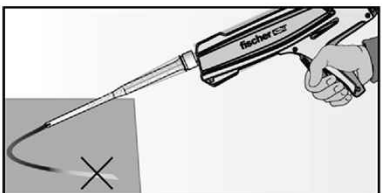
4		<p>Before use, make asure that the rebar is dry and free of oil or other residue. Mark the embedment depth l_v (e.g. with tape) Insert rebar in borehole, to verify drill hole depth and setting depth l_v resp. $l_{e,ges}$.</p>
5		<p>Twist off the sealing cap Twist on the static mixer (the spiral in the static mixer must be clearly visible).</p>
6		<p>Place the cartridge into a suitable dispenser.</p>
7		<p>Press out approximately 10 cm of mortar until the resin is permanently grey in colour. Mortar which is not grey in colour will not cure and must be disposed.</p>

Rebar connection with injection system FIS VL

Intended use
Installation instruction part 3,
reinforcing bars (rebar) and cartridge preparation

Annex B8
Appendix 13 / 16

Installation instruction part 4; Installation with FIS VL

Injection of the mortar without extension tube

8a

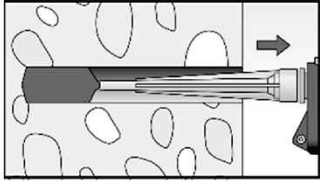

Inject the mortar from the back of the hole towards the front and slowly withdraw the static mixer step by step with each trigger pull. Avoid bubbles. Fill holes approximately 2/3 full, to ensure that the annular gap between the rebar and the concrete will be completely filled with adhesive over the entire embedment length. The conditions for mortar injection without extension tube can be found in **Table B4.3**.

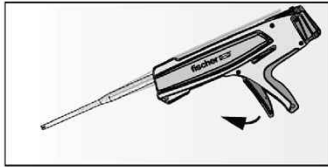

After injecting, release the dispenser. This will prevent further mortar discharge from the static mixer.

Injection of the mortar with extension tube

8b

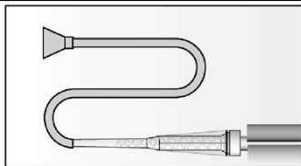

Assemble static mixer FIS MR Plus or FIS JMR, extension tube and appropriate injection adapter (see **Table B5.2**).

Mortar level mark

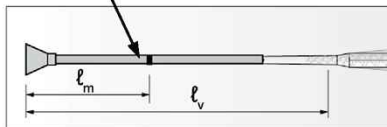

Mark the required mortar level l_m and embedment depth l_v resp. $l_{e,ges}$ with tape or marker on the injection extension tube.

a) Estimation:

$$l_m = \frac{1}{3} \cdot l_v \text{ resp. } l_m = \frac{1}{3} \cdot l_{e,ges} \text{ [mm]}$$

b) Precise equation for optimum mortar volume:

$$l_m = l_v \text{ resp. } l_{e,ges} \left(\left(1,2 \cdot \frac{d_s^2}{d_0^2} - 0,2 \right) \right) \text{ [mm]}$$

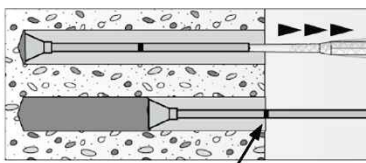

Mortar level mark

Insert injection adapter to back of the hole. Begin injection allowing the pressure of the injected adhesive mortar to push the injection adapter towards the front of the hole. Do not actively pull out! Fill holes approximately 2/3 full, to ensure that the annular gap between the rebar and the concrete will be completely filled with adhesive over the embedment length. When using an injection adapter continue injection until the mortar level mark l_m becomes visible. Maximum embedment depth see **Table B4.2**.

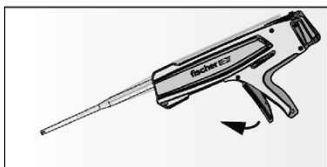

After injecting, release the dispenser. This will prevent further mortar discharge from static mixer.

Rebar connection with injection system FIS VL

Intended use



Installation instruction part 4, mortar injection

Annex B9

Appendix 14 / 16

Installation instruction part 5; Installation with FIS VL

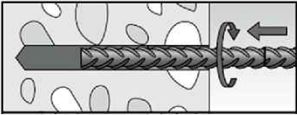
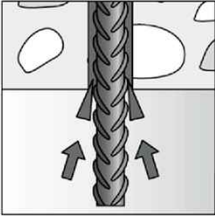
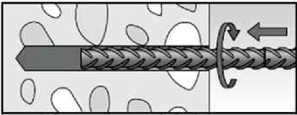
Insert rebar

9		<p>Insert the rebar slowly twisted into the borehole until the embedment mark is reached. Recommendation: Rotation back and forth of the reinforcement bar makes pushing easy.</p>
10		<p>For overhead installation, support the rebar and secure it from falling till mortar started to harden, e.g. using wedges.</p>
11		<p>After installing the rebar the annular gap must be completely filled with mortar.</p> <p>Proper installation</p> <ul style="list-style-type: none"> • Desired embedment depth is reached l_v, resp. $l_{e,ges}$: embedment mark at concrete surface • Excess mortar flows out of the borehole after the rebar has been fully inserted up to the embedment mark.
12		<p>Observe the working time "t_{work}" (see Table B5.1), which varies according to temperature of base material. Minor adjustments to the rebar position may be performed during the working time</p> <p>Full load may be applied only after the curing time "t_{cure}" has elapsed (see Table B5.1).</p>

Rebar connection with injection system FIS VL

Intended use
 Installation instruction part 5, insert rebar

Minimum anchorage length and minimum lap length

The minimum anchorage length $l_{b,min}$ and the minimum lap length $l_{0,min}$ according to EN 1992-1-1:2011 shall be multiplied by the relevant amplification factor α_{lb} according to **Table C1.1**.

Table C1.1: Amplification factor α_{lb} related to concrete strength class and drilling method

Hammer drilling, hollow drilling and compressed air drilling				
Rebar ϕ [mm]	Amplification factor α_{lb}			
	Concrete strength class			
	C20/25	C25/30	C30/37	C35/45
10 to 25	1,0			

Table C1.2: Bond efficiency factor k_b related to concrete strength class and drilling method

Hammer drilling, hollow drilling and compressed air drilling				
Rebar ϕ [mm]	Bond efficiency factor k_b			
	Concrete strength class			
	C20/25	C25/30	C30/37	C35/45
10 to 25	1,0			

Table C1.3: Design values of the bond strength $f_{bd,PIR}$ in N/mm² related to concrete strength class and drilling method for good bond conditions

$$f_{bd,PIR} = k_b \cdot f_{bd}$$

f_{bd} : Design value of the bond strength in N/mm² considering the concrete strength classes and the rebar diameter for good bond condition (for all other bond conditions multiply the values by $\eta_1 = 0,7$) and recommended partial factor $\gamma_c = 1,5$ according to EN 1992-1-1: 2011

k_b : Bond efficiency factor according to **Table C1.2**

Hammer drilling, hollow drilling and compressed air drilling

Rebar ϕ [mm]	Bond strength $f_{bd,PIR}$ [N/mm ²]			
	Concrete strength class			
	C20/25	C25/30	C30/37	C35/45
10 to 25	2,3	2,7	3,0	3,4

Rebar connection with injection system FIS VL

Performance

Amplification factor α_{lb} , bond efficiency factor k_b , design values of the bond strength $f_{bd,PIR}$

Annex C1

Appendix 16 / 16