

DECLARAȚIA DE PERFORMANȚĂ

DoP 0319

pentru sistem de injecție fischer FIS P Plus (Ancore din metal pentru utilizare în beton)

RO

- Cod unic de identificare al produsului-tip:** DoP 0319
- Utilizare (utilizări) preconizată (preconizate):** Prindere cu instalare ulterioară în beton nefisurat, consultați suplimentul, în special anexele B1 - B7.
- Fabricant:** fischerwerke GmbH & Co. KG, Otto-Hahn-Straße 15, 79211 Denzlingen, Germany
- Reprezentant autorizat:** -
- Sistemul (sistemele) de evaluare și de verificare a constantei performanței:** 1
- Documentul de evaluare european:** EAD 330499-00-0601
Evaluarea tehnică europeană: ETA-18/0383; 2018-09-06
Organismul de evaluare tehnică: DIBt- Deutsches Institut für Bautechnik
Organism (organisme) notificat(e): 2873 TU Darmstadt
- Performanța (performanțe) declarată (declarate):**
Rezistență mecanică și stabilitate (BWR 1)
Rezistența caracteristică la întindere (pentru încărcări statice și cvasistatice):
Rezistența la cedarea oțelului: Anexa C1
Rezistența în ipoteza cedării conului de beton combinată cu smulgerea ancorei: Anexa C3
Rezistența la cedarea conului de beton: Anexa C2
Distanța față de margine pentru a preveni fisuri sub încărcare: Anexa C2
Robustețe: Anexele C2, C3
Momentul maxim de strângere: Anexa B3
Distanța minimă față de margine și între ancore: Anexa B3

Rezistența caracteristică la forfecare (pentru încărcări statice și cvasistatice):
Rezistența la cedarea oțelului: Anexa C1
Rezistența la cedarea cu braț de levier: Anexa C2
Rezistența la cedarea muchiei betonului: Anexa C2

Deplasări în condiții de încărcare pe termen scurt și pe termen lung:
Deplasări în condiții de încărcare pe termen scurt și pe termen lung: Anexa C3

Rezistență caracteristică și Deplasări pentru performanță seismică de categoriile C1 și C2:
Rezistența la cedarea oțelului: NPD
Rezistența la smulgere: NPD
Alungirea la rupere: NPD
Factor gol circular: NPD
Deplasări: NPD

Igienă, sănătate și mediu (BWR 3)
Conținutul, emisia și / sau eliberarea de substanțe periculoase: NPD
- Documentație tehnică adecvată și/sau documentație tehnică specifică:** -

$k_{cr,N} = \text{NPD}$

Performanța produsului identificat mai sus este în conformitate cu setul de performanțe declarate. Această declarație de performanță este eliberată în conformitate cu Regulamentul (UE) nr. 305/2011, pe răspunderea exclusivă a fabricantului identificat mai sus.

Semnata pentru și în numele fabricantului de către:



Dr.-Ing. Oliver Geibig, Director Executiv Departament Business & Inginerie
Tumlingen, 2024-01-21

Jürgen Grün, Director Executiv Departament Chemic & Calitate

Această declarație de performanță a fost întocmită în mai multe limbi. În cazul unei divergențe de interpretare, versiunea în limba engleză prevalează întotdeauna.

Suplimentul include informații voluntare și complementare în limba engleză, în afara cerințelor legale (specificate neutru din punct de vedere al limbii).

Specific Part

1 Technical description of the product

The fischer injection system FIS P Plus is a bonded anchor consisting of a cartridge with injection mortar fischer FIS P Plus and a steel element according to Annex A 3.

The steel element is placed into a drilled hole filled with injection mortar and is anchored via the bond between metal part, injection mortar and concrete.

The product description is given in Annex A.

2 Specification of the intended use in accordance with the applicable European Assessment Document

The performances given in Section 3 are only valid if the anchor is used in compliance with the specifications and conditions given in Annex B.

The verifications and assessment methods on which this European Technical Assessment is based lead to the assumption of a working life of the anchor of at least 50 years. The indications given on the working life cannot be interpreted as a guarantee given by the producer, but are to be regarded only as a means for choosing the right products in relation to the expected economically reasonable working life of the works.

3 Performance of the product and references to the methods used for its assessment

3.1 Mechanical resistance and stability (BWR 1)

Essential characteristic	Performance
Characteristic resistance to tension load (static and quasi-static loading)	See Annex C 1 to C 3
Characteristic resistance to shear load (static and quasi-static loading)	See Annex C 1 and C 2
Displacements (static and quasi-static loading)	See Annex C 3
Characteristic resistance and displacements for seismic performance categories C1 and C2	No performance assessed

3.2 Hygiene, health and the environment (BWR 3)

Essential characteristic	Performance
Content, emission and/or release of dangerous substances	No performance assessed

4 Assessment and verification of constancy of performance (AVCP) system applied, with reference to its legal base

In accordance with the European Assessment Document EAD 330499-00-0601 the applicable European legal act is: [96/582/EC].

The system to be applied is: 1

Installation conditions part 1

fischer anchor rod

Pre positioned installation

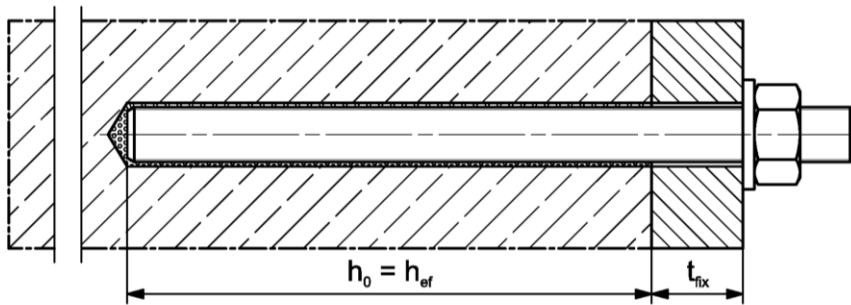

Push through installation (annular gap filled with mortar)

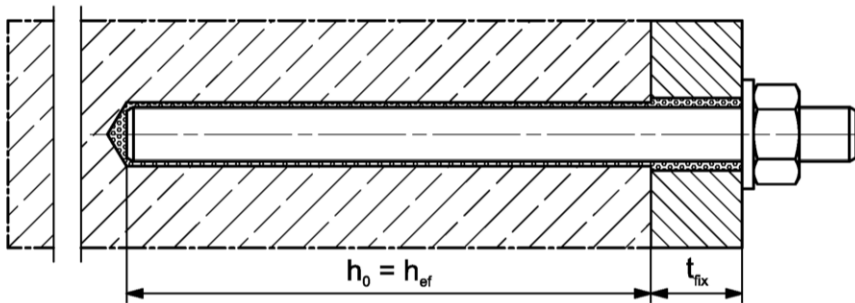

Pre-positioned or push through installation with subsequently pressed filling disk (annular gap filled with mortar)

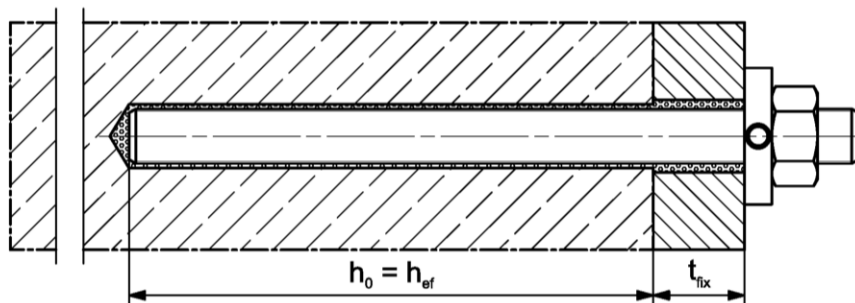

Figures not to scale

h_0 = drill hole depth

h_{ef} = effective embedment depth

t_{fix} = thickness of fixture

fischer injection system FIS P Plus

Product description
Installation conditions part 1

Annex A 1

Appendix 2 / 15

Overview system components part 1

Injection cartridge (shuttle cartridge) with sealing cap; Size: 345 ml, 360 ml, 390 ml, 550 ml, 950 ml, 1500 ml

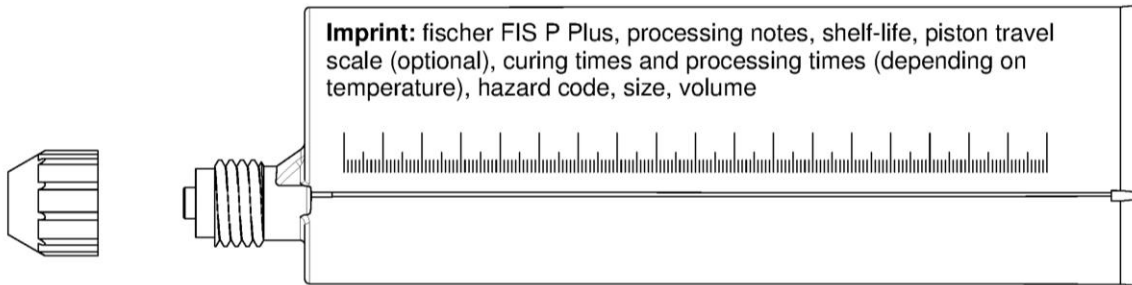

Injection cartridge (coaxial cartridge) with sealing cap; Size: 100 ml, 150 ml, 300 ml, 380 ml, 400 ml, 410 ml

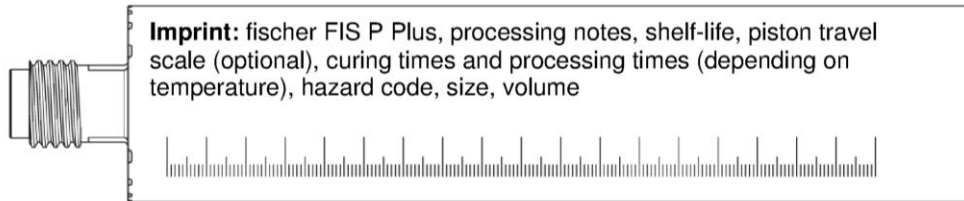

Static mixer FIS MR Plus or UMR

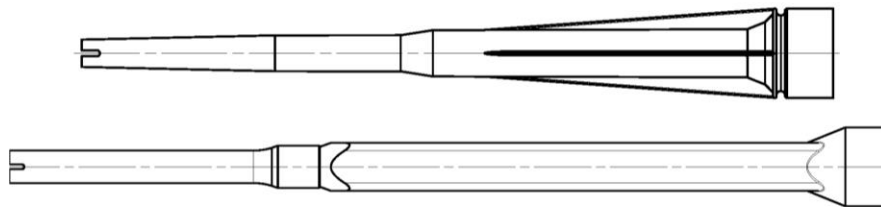

Injection adapter and Extension tube for static mixer

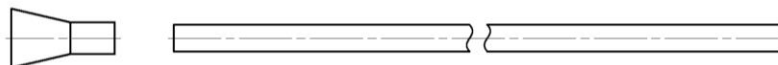

Cleaning brush BS / BSB



Blow-out pump ABG or ABP



Figures not to scale

fischer injection system FIS P Plus

System description

Overview system components part 1;
cartridges / static mixer / accessories

Annex A 2

Appendix 3 / 15

Overview system components part 2

fischer anchor rod

Size: M8, M10, M12, M16, M20 ,M24

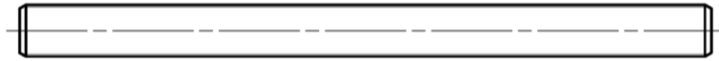

washer / hexagon nut

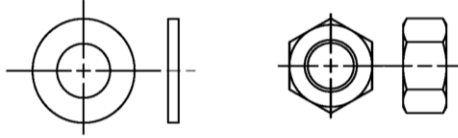

fischer filling disk FFD with injection adapter

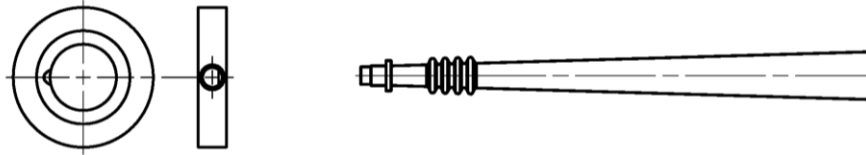

Figures not to scale

fischer injection system FIS P Plus

System description

Overview system components part 2;
steel components

Annex A 3

Appendix 4 / 15

Table A4.1: Materials

Part	Designation	Material		
1	Injection cartridge	Mortar, hardener, filler		
	Steel grade	Steel, zinc plated	Stainless steel A4	High corrosion resistant steel C
2	Anchor rod	Property class 5.8 or 8.8; EN ISO 898-1:2013 zinc plated $\geq 5 \mu\text{m}$, EN ISO 4042:1999 A2K or hot-dip galvanized $\geq 40 \mu\text{m}$ EN ISO 10684:2004 $f_{uk} \leq 1000 \text{ N/mm}^2$ $A_5 > 8\%$ fracture elongation	Property class 50, 70 or 80 EN ISO 3506-1:2009 1.4401; 1.4404; 1.4578; 1.4571; 1.4439; 1.4362; 1.4062, 1.4662, 1.4462; EN 10088-1:2014 $f_{uk} \leq 1000 \text{ N/mm}^2$ $A_5 > 8\%$ fracture elongation	Property class 50 or 80 EN ISO 3506-1:2009 or property class 70 with $f_{yk} = 560 \text{ N/mm}^2$ 1.4565; 1.4529; EN 10088-1:2014 $f_{uk} \leq 1000 \text{ N/mm}^2$ $A_5 > 8\%$ fracture elongation
3	Washer ISO 7089:2000	zinc plated $\geq 5 \mu\text{m}$, EN ISO 4042:1999 A2K or hot-dip galvanized $\geq 40 \mu\text{m}$ EN ISO 10684:2004	1.4401; 1.4404; 1.4578; 1.4571; 1.4439; 1.4362; EN 10088-1:2014	1.4565; 1.4529; EN 10088-1:2014
4	Hexagon nut	Property class 5 or 8; EN ISO 898-2:2012 zinc plated $\geq 5 \mu\text{m}$, ISO 4042:1999 A2K or hot-dip galvanized $\geq 40 \mu\text{m}$ EN ISO 10684:2004	Property class 50, 70 or 80 EN ISO 3506-1:2009 1.4401; 1.4404; 1.4578; 1.4571; 1.4439; 1.4362; EN 10088-1:2014	Property class 50, 70 or 80 EN ISO 3506-1:2009 1.4565; 1.4529 EN 10088-1:2014
5	fischer filling disk FFD similar to DIN 6319-G	zinc plated $\geq 5 \mu\text{m}$, EN ISO 4042:1999 A2K or hot-dip galvanized $\geq 40 \mu\text{m}$ EN ISO 10684:2004	1.4401; 1.4404; 1.4578; 1.4571; 1.4439; 1.4362; EN 10088-1:2014	1.4565; 1.4529; EN 10088-1:2014



fischer injection system FIS P Plus

Product description
 Materials
Annex A 4

Appendix 5 / 15

Specifications of intended use (part 1)

Table B1.1: Overview use and performance categories

Anchorages subject to		FIS P Plus with ...	
		Anchor rod 	
Hammer drilling with standard drill bit 		all sizes	
Hammer drilling with hollow drill bit (Heller "Duster Expert"; Bosch „Speed Clean“; Hilti "TE-CD, TE-YD") 		Nominal drill bit diameter (d_0) 12 mm to 28 mm	
Static and quasi static load, in	uncracked concrete	all sizes	Tables: C1.1 C2.1 C3.1 C3.2
Use category	I1	dry or wet concrete	all sizes
	I2	Flooded hole	M12 to M24
Installation direction		D3 (downward and horizontal and upwards (e.g. overhead) installation)	
Installation temperature		$T_{i,min} = 0\text{ °C}$ to $T_{i,max} = +40\text{ °C}$	
In-service temperature	Temperature range I	-40 °C to +40 °C	(max. short term temperature +40 °C ; max. long term temperature +24 °C)
	Temperature range II	-40 °C to +80 °C	(max. short term temperature +80 °C ; max. long term temperature +50 °C)

fischer injection system FIS P Plus

Intended use
Specifications (part 1)

Annex B 1

Appendix 6 / 15

Specifications of intended use (part 2)

Base materials:

- Compacted reinforced or unreinforced normal weight concrete without fibres of strength classes C20/25 to C50/60 according to EN 206:2013

Use conditions (Environmental conditions):

- Structures subject to dry internal conditions (zinc coated steel, stainless steel or high corrosion resistant steel)
- Structures subject to external atmospheric exposure (including industrial and marine environment) and to permanently damp internal condition, if no particular aggressive conditions exist (stainless steel or high corrosion resistant steel)
- Structures subject to external atmospheric exposure, to permanently damp internal conditions or in other particular aggressive conditions (high corrosion resistant steel)

Note: Particular aggressive conditions are e. g. permanent, alternating immersion in seawater or the splash zone of seawater, chloride atmosphere of indoor swimming pools or atmosphere with extreme chemical pollution (e. g. in desulphurization plants or road tunnels where de-icing materials are used)

Design:

- Anchorages have to be designed by a responsible engineer with experience of concrete anchor design.
- Verifiable calculation notes and drawings are to be prepared taking account of the loads to be anchored. The position of the anchor is indicated on the design drawings (e. g. position of the anchor relative to reinforcement or to supports, etc.)
- Anchorages are designed in accordance with FprEN 1992-4:2017 and EOTA Technical Report TR 055

Installation:

- Anchor installation is to be carried out by appropriately qualified personnel and under the supervision of the person responsible for technical matters of the site
- In case of aborted hole: The hole shall be filled with mortar
- Anchorage depth should be marked and adhered to on installation
- Overhead installation is allowed

fischer injection system FIS P Plus

Intended use
Specifications (part 2)

Annex B 2

Appendix 7 / 15

Table B3.1: Installation parameters plus minimum spacing and minimum edge distance for anchor rods

Anchor rods		Thread	M8	M10	M12	M16	M20	M24
Width across flats	SW	[mm]	13	17	19	24	30	36
Nominal drill hole diameter	d_0		10	12	14	18	24	28
Drill hole depth	h_0		$h_0 = h_{ef}$					
Effective embedment depth	$h_{ef, min}$		60	60	70	80	90	96
	$h_{ef, max}$		160	200	240	320	400	480
Minimum spacing and minimum edge distance	s_{min} = c_{min}		40	45	55	65	85	105
	Diameter of the clearance hole of the fixture		pre positioned installation d_f	9	12	14	18	22
push through installation d_f			11	14	16	20	26	30
Minimum thickness of concrete member	h_{min}		$h_{ef} + 30 (\geq 100)$			$h_{ef} + 2d_0$		
Maximum torque moment for attachment of the fixture	$\max T_{fix}$		[Nm]	10	20	40	60	120

fischer anchor rod

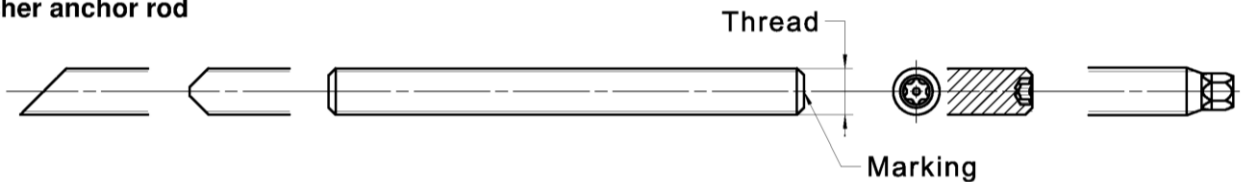

Marking (on random place) fischer anchor rod:

Property class 8.8, stainless steel, property class 80 and high corrosion resistant steel, property class 80: •
 Stainless steel A4, property class 50 and high corrosion resistant steel, property class 50: ••
 Alternatively: Colour coding according to DIN 976-1

Installation conditions:

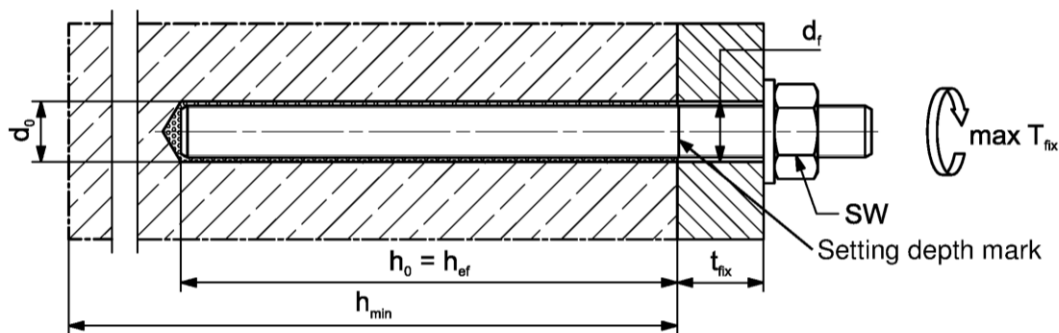

Commercial standard threaded rods, washers and hexagon nuts may also be used if the following requirements are fulfilled

- Materials, dimensions and mechanical properties according to Annex A 4, Table A4.1
- Inspection certificate 3.1 according to EN 10204:2004, the documents have to be stored
- Setting depth is marked

Figures not to scale

fischer injection system FIS P Plus

Intended use
 Installation parameters anchor rods

Annex B 3

Appendix 8 / 15

Table B4.1: Parameters of the cleaning brush BS (steel brush)

The size of the cleaning brush refers to the drill hole diameter

Nominal drill hole diameter	d_0	[mm]	10	12	14	18	24	28
Steel brush diameter	d_b		11	14	16	20	26	30

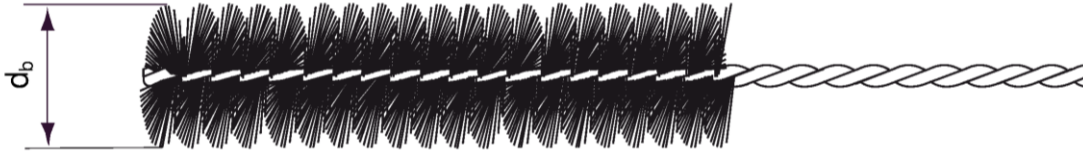

Table B4.2 Maximum processing time of the mortar and minimum curing time
(During the curing time of the mortar the concrete temperature may not fall below the listed minimum temperature)

Temperature at anchoring base [°C]	Maximum processing time t_{work}	Minimum curing time t_{cure}
>±0 to +5	13 min	3 h
>+5 to +10	9 min	90 min
>+10 to +20	5 min	60 min
>+20 to +30	4 min	45 min
>+30 to +40	2 min	35 min

¹⁾ In wet concrete or water filled holes the curing times must be doubled

fischer injection system FIS P Plus

Intended use

Cleaning brush (steel brush)
Processing time and curing time

Annex B 4

Appendix 9 / 15

Installation instructions part 1

Drilling and cleaning the hole (hammer drilling with standard drill bit)

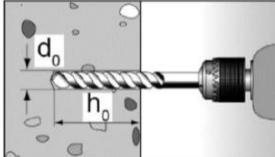
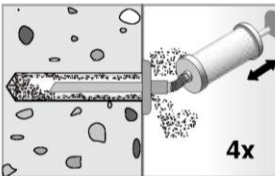
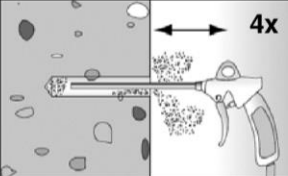
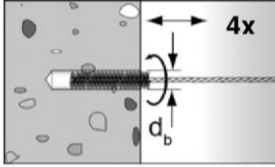
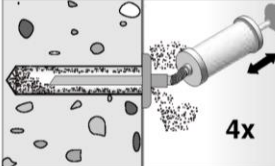
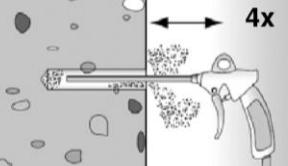
1		<p>Drill the hole. Nominal drill hole diameter d_0 and drill hole depth h_0 see tables B3.1</p>	
2		<p>Clean the drill hole: For $h_{ef} \leq 12d$ and $d_0 < 18$ mm blow out the hole four times by hand</p>	 <p>For $h_{ef} > 12d$ and / or $d_0 \geq 18$ mm blow out the hole four times with oil-free compressed air ($p \geq 6$ bar)</p>
3		<p>Brush the drill hole four times. For deep holes use an extension. Corresponding brushes see table B4.1</p>	
4		<p>Clean the drill hole: For $h_{ef} \leq 12d$ and $d_0 < 18$ mm blow out the hole four times by hand</p>	 <p>For $h_{ef} > 12d$ and / or $d_0 \geq 18$ mm blow out the hole four times with oil-free compressed air ($p \geq 6$ bar)</p>

Go to step 5

Drilling and cleaning the hole (hammer drilling with hollow drill bit)

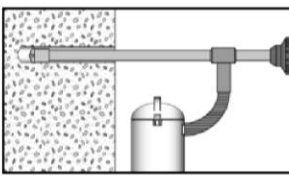
1		<p>Check a suitable hollow drill (see table B1.1) for correct operation of the dust extraction</p>
2		<p>Use a suitable dust extraction system, e. g. Bosch GAS 35 M AFC or a comparable dust extraction system with equivalent performance data</p> <p>Drill the hole with hollow drill bit. The dust extraction system has to extract the drill dust nonstop during the drilling process and must be adjusted to maximum power. Nominal drill hole diameter d_0 and drill hole depth h_0 see tables B3.1</p>

Go to step 5

fischer injection system FIS P Plus



Intended use
Installation instructions part 1

Annex B 5

Appendix 10 / 15

Installation instructions part 2

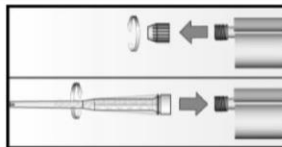
Preparing the cartridge

5		<p>Remove the sealing cap</p> <p>Screw on the static mixer (the spiral in the static mixer must be clearly visible)</p>
6		<p>Place the cartridge into the dispenser</p>
7		<p>Extrude approximately 10 cm of material out until the resin is evenly grey in colour. Do not use mortar that is not uniformly grey</p>

Injection of the mortar

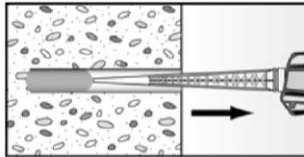
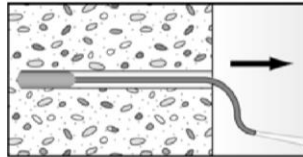
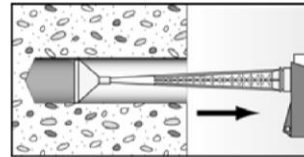
8	 <p>Fill approximately 2/3 of the drill hole with mortar. Always begin from the bottom of the hole and avoid bubbles</p>	 <p>For drill hole depth ≥ 150 mm use an extension tube</p>	 <p>For overhead installation, deep holes ($h_0 > 250$ mm) use an injection-adapter</p>
---	---	--	--

fischer injection system FIS P Plus



Intended use
Installation instructions part 2

Annex B 6

Appendix 11 / 15

Installation instructions part 3

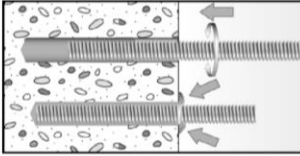
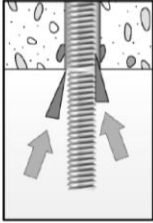
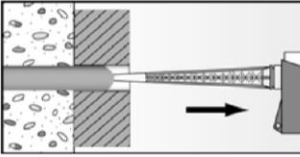
Installation of anchor rods

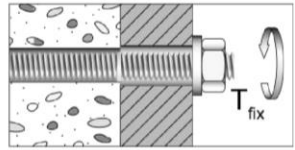
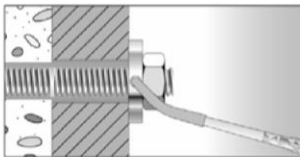
9		<p>Only use clean and oil-free anchor elements. Mark the setting depth of the anchor. Push the anchor rod down to the bottom of the hole, turning it slightly while doing so. After inserting the anchor element, excess mortar must be emerged around the anchor element.</p>
	 <p>For overhead installations support the anchor rod with wedges. (e. g. fischer centering wedges)</p>	 <p>For push through installation fill the annular gap with mortar</p>
10	 <p>Wait for the specified curing time t_{cure} see table B4.2</p>	<p>11</p>  <p>Mounting the fixture max T_{fix} see tables B3.1</p>
Option		<p>After the minimum curing time is reached, the gap between anchor and fixture (annular clearance) may be filled with mortar via the fischer filling disc FFD. Compressive strength $\geq 50 \text{ N/mm}^2$ (e.g. fischer injection mortars FIS HB, FIS SB, FIS V, FIS EM Plus, FIS P Plus) ATTENTION: Using fischer filling disc FFD reduces t_{fix} (usable length of the anchor)</p>

fischer injection system FIS P Plus

Intended use
 Installation instructions part 3

Annex B 7

Appendix 12 / 15

Table C1.1: Essential characteristic for the **steel bearing capacity** under tensile / shear load of **fischer anchor rods** and **standard threaded rods**

Anchor rod / standard threaded rod		M8	M10	M12	M16	M20	M24			
Bearing capacity under tensile load, steel failure³⁾										
Characteristic resistance $N_{Rk,s}$	Steel zinc plated	5.8	Property class	[kN]	19 (17)	29 (27)	43	79	123	177
		8.8			29 (27)	47 (43)	68	126	196	282
	Stainless steel A4 and high corrosion resistant steel C	50			19	29	43	79	123	177
		70			26	41	59	110	172	247
		80			30	47	68	126	196	282
Partial factors¹⁾										
Partial factor $\gamma_{Ms,N}$	Steel zinc plated	5.8	Property class	[-]	1,50					
		8.8			1,50					
	Stainless steel A4 and high corrosion resistant steel C	50			2,86					
		70			1,50 ²⁾ / 1,87					
		80			1,60					
Bearing capacity under shear load, steel failure without lever arm³⁾										
Characteristic resistance $V_{Rk,s}^0$	Steel zinc plated	5.8	Property class	[kN]	9 (8)	15 (13)	21	39	61	89
		8.8			15 (13)	23 (21)	34	63	98	141
	Stainless steel A4 and high corrosion resistant steel C	50			9	15	21	39	61	89
		70			13	20	30	55	86	124
		80			15	23	34	63	98	141
Ductility factor	k_7	[-]	1,0							
with lever arm³⁾										
Charact. resistance $M_{Rk,s}^0$	Steel zinc plated	5.8	Property class	[Nm]	19 (16)	37 (33)	65	166	324	560
		8.8			30 (26)	60 (53)	105	266	519	896
	Stainless steel A4 and high corrosion resistant steel C	50			19	37	65	166	324	560
		70			26	52	92	232	454	784
		80			30	60	105	266	519	896
Partial factors¹⁾										
Partial factor $\gamma_{Ms,V}$	Steel zinc plated	5.8	Property class	[-]	1,25					
		8.8			1,25					
	Stainless steel A4 and high corrosion resistant steel C	50			2,38					
		70			1,25 ²⁾ / 1,56					
		80			1,33					

¹⁾ In absence of other national regulations

²⁾ Only admissible for steel C, with $f_{yk} / f_{uk} \geq 0,8$ and $A_5 > 12 \%$ (e.g. fischer anchor rods)

³⁾ Values in brackets are valid for undersized threaded rods with smaller stress area A_s for hotdip galvanised standard threaded rods according to EN ISO 10684:2004+AC:2009.

fischer injection steel system FIS P Plus

Performances

Essential characteristics for the steel bearing capacity of fischer anchor rods and standard threaded rods

Annex C 1

Appendix 13 / 15

Table C2.1: Essential characteristics under tensile / shear load								
Size			All sizes					
Tensile load								
Uncracked concrete		$k_{Ucr,N}$	[-]	11,0				
Factors for the compressive strength of concrete > C20/25								
Increasing factor for τ_{Rk}	C25/30	Ψ_c	[-]	1,05				
	C30/37			1,10				
	C35/45			1,15				
	C40/50			1,19				
	C45/55			1,22				
	C50/60			1,26				
Splitting failure								
Edge distance	$h / h_{ef} \geq 2,0$	$c_{cr,sp}$	[mm]	1,0 h_{ef}				
	$2,0 > h / h_{ef} > 1,3$			4,6 h_{ef} - 1,8 h				
	$h / h_{ef} \leq 1,3$			2,26 h_{ef}				
Spacing	$s_{cr,sp}$			2 $c_{cr,sp}$				
Concrete cone failure								
Edge distance	$c_{cr,N}$	[mm]		1,5 h_{ef}				
Spacing	$s_{cr,N}$			2 $c_{cr,N}$				
Installation factor tensile load	γ_{inst}	[-]		1,2				
Shear load								
Installation factor shear load	γ_{inst}	[-]		1,0				
Concrete pry-out failure								
Factor for pry-out failure	k_g	[-]		2,0				
Calculation diameters								
Size			M8	M10	M12	M16	M20	M24
fischer anchor rods and standard threaded rods	d_{nom}	[mm]	8	10	12	16	20	24
fischer injection system FIS P Plus							Annex C 2 Appendix 14 / 15	
Performances Essential characteristics under tensile / shear load								

Table C3.1: Essential characteristics of **tensile resistance** for **fischer anchor rods** and **standard threaded rods** in hammer drilled holes; **uncracked concrete**

Anchor rod / standard threaded rod		M8	M10	M12	M16	M20	M24	
Combined pullout and concrete cone failure								
Calculation diameter	d [mm]	8	10	12	16	20	24	
Uncracked concrete								
Characteristic bond resistance in uncracked concrete C20/25								
Hammer-drilling with standard drill bit or hollow drill bit (dry or wet concrete)								
Temperature range	I: 24 °C / 40 °C	$\tau_{RK,ucr}$ [N/mm ²]	7,5	7,5	7,5	7,5	7	7
	II: 50 °C / 80 °C		6,5	6,5	6,5	6,5	6	6
Hammer-drilling with standard drill bit or hollow drill bit (flooded hole)								
Temperature range	I: 24 °C / 40 °C	$\tau_{RK,ucr}$ [N/mm ²]	---	---	7,5	7,5	7	7
	II: 50 °C / 80 °C		---	---	6,5	6,5	6	6
Installation factors								
Dry or wet concrete	γ_{inst} [-]	1,0						
Flooded hole		---			1,2 ¹⁾			

¹⁾ Only with coaxial cartridges: 380ml, 400 ml, 410 ml

Table C3.2: Displacements for anchor rods

Anchor rod		M8	M10	M12	M16	M20	M24
Displacement-Factors for tensile load¹⁾							
Uncracked concrete; Temperature range I, II							
δ_{N0} -Factor	[mm/(N/mm ²)]	0,09	0,09	0,10	0,10	0,10	0,10
$\delta_{N\infty}$ -Factor		0,10	0,10	0,12	0,12	0,12	0,13
Displacement-Factors for shear load²⁾							
Uncracked concrete; Temperature range I, II							
δ_{V0} -Factor	[mm/kN]	0,11	0,11	0,10	0,10	0,09	0,09
$\delta_{V\infty}$ -Factor		0,12	0,12	0,11	0,11	0,10	0,10

¹⁾ Calculation of effective displacement:

$$\delta_{N0} = \delta_{N0}\text{-Factor} \cdot \tau_{Ed}$$

$$\delta_{N\infty} = \delta_{N\infty}\text{-Factor} \cdot \tau_{Ed}$$

(τ_{Ed} : Design value of the applied tensile stress)

²⁾ Calculation of effective displacement:

$$\delta_{V0} = \delta_{V0}\text{-Factor} \cdot V_{Ed}$$

$$\delta_{V\infty} = \delta_{V\infty}\text{-Factor} \cdot V_{Ed}$$

(V_{Ed} : Design value of the applied shear force)

fischer injection system FIS P Plus

Performances

Essential characteristics of tensile resistance for fischer anchor rod, standard threaded rods (uncracked concrete), Displacement for anchor rods