



DECLARAȚIA DE PERFORMANȚĂ

DoP 0267

pentru fischer Ceiling Anchor FDN II (Ancore din metal pentru utilizare în beton)

RO

- Cod unic de identificare al produsului-tip:** DoP 0267
- Utilizare (utilizări) preconizată (preconizate):** Element de fixare post-instalat pentru utilizare în beton pentru sisteme nestructurale redundante, consultați suplimentul, în special anexele B1 - B2.
- Fabricant:** fischerwerke GmbH & Co. KG, Klaus-Fischer-Str. 1, 72178 Waldachtal, Germany
- Reprezentant autorizat:** -
- Sistemul (sistemele) de evaluare și de verificare a constantei performanței:** 2+
- Documentul de evaluare european:** ETAG 001, Part 6, April 2013, folosit ca EAD
Evaluarea tehnică europeană: ETA-17/0736; 2018-01-30
Organismul de evaluare tehnică: DIBt- Deutsches Institut für Bautechnik
Organism (organisme) notificat(e): 2873 TU Darmstadt
- Performanța (performanțe) declarată (declarate):**
Siguranță în utilizare (BWR 4)
Rezistența caracteristică la întindere (pentru încărcări statice și cvasistatice):

Rezistența la cedarea oțelului:	NPD
Rezistența la smulgere:	NPD
Rezistența la cedarea conului de beton:	NPD
Robustețe:	Anexa C1
Distanța minimă față de margine și între ancore:	Anexele B2, C1
Distanța față de margine pentru a preveni fisuri sub încărcare:	NPD

Rezistența caracteristică la forfecare (pentru încărcări statice și cvasistatice):

Rezistența la cedarea oțelului (rezistența la forfecare):	Anexa C1	$V_{Rk,s}=NPD; k_{\gamma}=NPD$
Rezistența la cedarea cu braț de levier:	NPD	
Rezistența la cedarea muchiei betonului:	NPD	

Rezistență caracteristică pentru toate direcțiile de încărcare și modurile de cedare pentru o proiectare simplificată:

Rezistență caracteristică:	Anexa C1
----------------------------	----------

Durabilitate:

Durabilitate:	Anexa B1
---------------	----------

Siguranța în caz de incendiu (BWR 2)

Reacție la foc:	Clasa (A1)
-----------------	------------

Rezistența la incendiu:

Rezistența la foc în ipoteza cedării oțelului (rezistența la întindere):	NPD
Rezistența la foc în ipoteza cedării prin smulgere (rezistența la întindere):	NPD
Rezistența la foc în ipoteza cedării oțelului (rezistența la forfecare):	NPD
Rezistența la foc pentru toate direcțiile de încărcare și modurile de cedare:	Anexa C1
- Documentație tehnică adecvată și/sau documentație tehnică specifică:** -

Performanța produsului identificat mai sus este în conformitate cu setul de performanțe declarate. Această declarație de performanță este eliberată în conformitate cu Regulamentul (UE) nr. 305/2011, pe răspunderea exclusivă a fabricantului identificat mai sus.

Semnată pentru și în numele fabricantului de către:

Dr.-Ing. Oliver Geibig, Director Executiv Departament Business & Inginerie
Tumlingen, 2021-01-11

Jürgen Grün, Director Executiv Departament Chimic & Calitate

Această declarație de performanță a fost întocmită în mai multe limbi. În cazul unei divergențe de interpretare, versiunea în limba engleză prevalează întotdeauna.

Suplimentul include informații voluntare și complementare în limba engleză, în afara cerințelor legale (specificate neutru din punct de vedere al limbii).

Specific Part

1 Technical description of the product

The Fischer Ceiling Anchor FDN II is an anchor made of galvanized steel which is placed into a drilled hole and anchored by deformation-controlled expansion.

The product description is given in Annex A.

2 Specification of the intended use in accordance with the applicable European Assessment Document

The performances given in Section 3 are only valid if the anchor is used in compliance with the specifications and conditions given in Annex B.

The verifications and assessment methods on which this European Technical Assessment is based lead to the assumption of a working life of the anchor of at least 50 years. The indications given on the working life cannot be interpreted as a guarantee given by the producer, but are to be regarded only as a means for choosing the right products in relation to the expected economically reasonable working life of the works.

3 Performance of the product and references to the methods used for its assessment

3.1 Mechanical resistance and stability (BWR 1)

The essential characteristics regarding mechanical resistance and stability are included under the Basic Works Requirement Safety in use.

3.2 Safety in case of fire (BWR 2)

Essential characteristic	Performance
Reaction to fire	Anchorage satisfies requirements for Class A1
Resistance to fire	See Annex C 1

3.3 Safety in use (BWR 4)

Essential characteristic	Performance
Characteristic resistance in concrete	See Annex C 1

4 Assessment and verification of constancy of performance (AVCP) system applied, with reference to its legal base

In accordance with guideline for European technical approval ETAG 001, April 2013 used as European Assessment Document (EAD) according to Article 66 Paragraph 3 of Regulation (EU) No 305/2011 the applicable European legal act is: [97/161/EC].

The system to be applied is: 2+

Product installation conditions, product marking and product dimensions

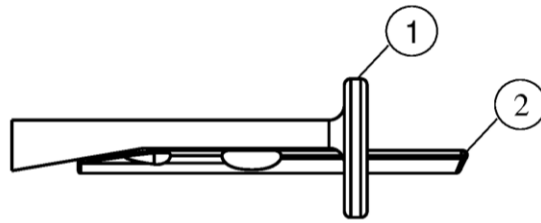

- ① Shaft
- ② Pin

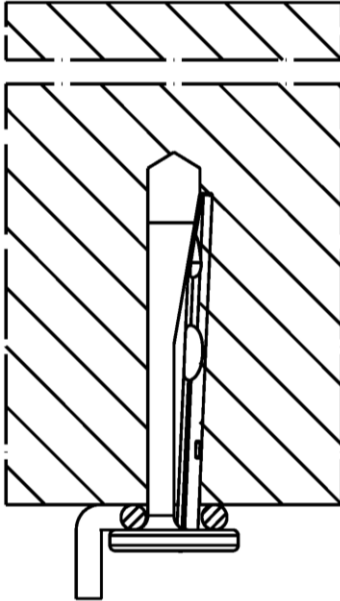

Type of fastener

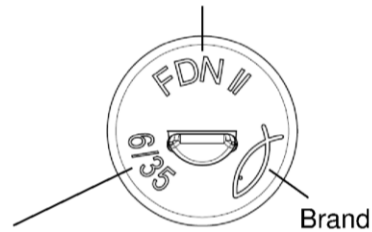

Brand

Nominal diameter / max. thickness of the fixture;
Additional marking "K" for $h_{ef} = 25$ mm

Table A1.1: Dimensions

Size	FDN II			
	6/5 K	6/5	6/35 K	6/35
Length of the $\frac{\text{pin}}{\text{shaft}}$ L_1	36	43	66	73
L_2 [mm]	30,5	37,5	60,5	67,5
Diameter of the head $D \geq$	13			

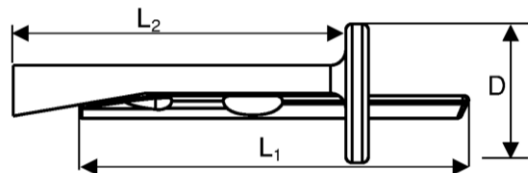

(Fig. not to scale)

fischer Ceiling Anchor FDN II

Product description

Product installation conditions, product marking and product dimensions

Annex A 1

Appendix 2 / 5

Specifications of intended use

Anchorage subject to:

Size	FDN II 6
Static and quasi-static loads	
Use for multiple fixture of non-structural applications according to ETAG 001, Part 6	✓
Fire exposure	

Base materials:

- Reinforced and unreinforced normal weight concrete according to EN 206-1:2000
- Strength classes C12/15 to C50/60 according to EN 206-1:2000
- Cracked and non-cracked concrete

Use conditions (Environmental conditions):

- Anchorage subject to dry internal conditions

Design:

- Anchorages are designed under the responsibility of an engineer experienced in anchorages and concrete work
- Verifiable calculation notes and drawings have to be prepared taking account of the loads to be anchored. The position of the anchor is indicated on the design drawings (e.g. position of the anchor relative to reinforcement or to supports, etc.).
- Anchorages under static or quasi-static actions have to be designed for Design Method C in accordance with:
 - ETAG 001, Annex C, Design Method C, Edition August 2010
 - CEN/TS 1992-4:2009
- Anchorages under fire exposure have to be designed in accordance with
 - EOTA Technical Report TR 020, Edition May 2004
 - CEN/TS 1992-4:2009, Annex D (it must be ensured that local spalling of the concrete cover does not occur)

fischer Ceiling Anchor FDN II

Intended use
Specifications

Annex B 1

Appendix 3 / 5

Table B2.1: Installation parameters

Size	FDN II			
	6/5 K	6/5	6/35 K	6/35
Thickness of the fixture	5		35	
Nominal drill hole diameter	6			
Diameter of clearance hole in the fixture	7			
Maximum bit diameter	6,40			
Effective embedment depth	25	32	25	32
Depth of drill hole	30	37	30	37
to deepest point	35	42	35	42
without hole cleaning				
Minimum thickness of concrete member	80			

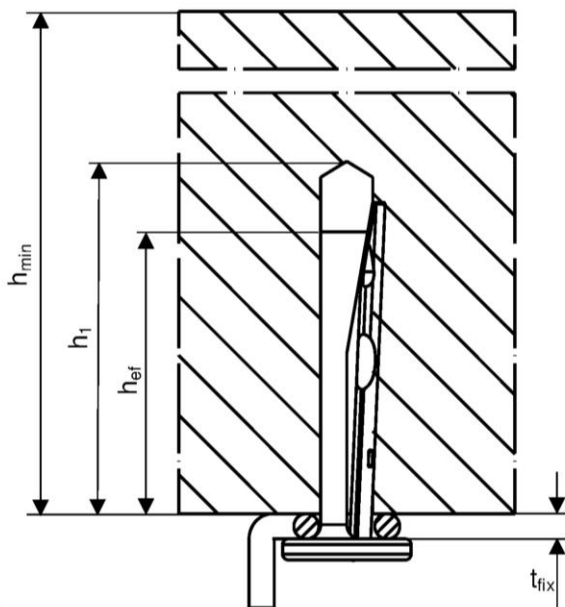

Installation instructions

- Hammer or hollow drilling only
- Anchor installation carried out by appropriately qualified personnel and under the supervision of the person responsible for technical matters of the site
- Positioning of the drill holes without damaging the reinforcement
- In case of aborted hole: New drilling at a minimum distance twice the depth of aborted hole away of or smaller distance if the aborted hole is filled with high strength mortar and if under shear or oblique tension load it is not in the direction of the load application

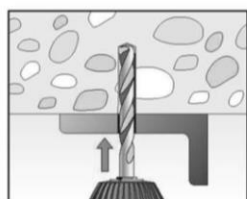

1: Drill the hole

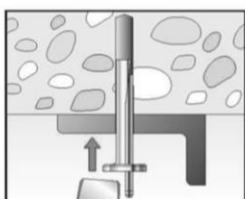

2: Set the fastener

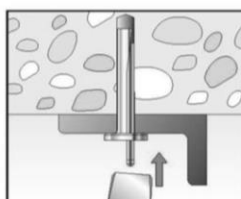

3: Set the pin, until flush to the surface

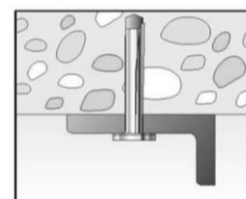

4: Installed fastener

(Fig. not to scale)

fischer Ceiling Anchor FDN II

Intended use

Installation parameters and installation instructions

Annex B 2

Appendix 4 / 5

Table C1.1: Characteristic resistance

Size	FDN II 6	
For all load directions and for all failures modes		
Effective embedment depth	h_{ef} [mm]	25 32
Characteristic resistance in cracked and non-cracked concrete	C12/15	2,0 2,5
	C20/25 to C50/60	2,5 3,5
Characteristic edge distance	$c_{cr,N} = c_{min}$ [mm]	70 60
	spacing	$s_{cr,N} = s_{min}$ [mm]
Partial safety factor	$\gamma_M^{2)}$ [-]	1,5
Shear load with lever arm		
Characteristic bending resistance	$M_{Rk,s}^0$ [Nm]	4,4
Partial safety factor for steel failure	$\gamma_{Ms}^{1)}$ [-]	1,25

1) In absence of other national regulations
 2) The installation safety factor $\gamma_2 = \gamma_{inst} = 1,0$ is included

Table C1.2: Characteristic resistance under fire exposure for all effective embedment depths

Size	FDN II 6	
Steel failure for tension and shear load		
R30	$F_{Rk,s,fi30}$	1,00
R60	$F_{Rk,s,fi60}$	0,50
R90	Characteristic resistance $F_{Rk,s,fi90}$ [kN]	0,34
R120	$F_{Rk,s,fi120}$	0,26
R180	$F_{Rk,s,fi180}$	0,17
Spacing and edge distance		
R30 – R120	$s_{cr,fi}$ [mm]	200
	$c_{cr,fi}$	150

For fire exposure from more than one side $c_{min} \geq 300$ mm