

## DECLARAÇÃO DE DESEMPENHO

### DoP 0404

para sistema de injeção fischer FIS VL (Argamassa para conexões de armaduras pós-instaladas)

PT

1. Código de identificação único do produto-tipo: **DoP 0404**
2. Utilização(ões) prevista(s): **Sistema para conexão de armaduras pós-instaladas com argamassa para uso em betão, Ver anexos, especialmente anexos B1-B10.**
3. Fabricante: **fischerwerke GmbH & Co. KG, Klaus-Fischer-Str. 1, 72178 Waldachtal, Alemanha**
4. Representante autorizado: **-**
5. Sistema(s) de avaliação e verificação da regularidade do desempenho (AVCP): **1**
6. Documento de Avaliação Europeu: **EAD 330087-01-0601 Edition 06/2021**  
Avaliação Técnica Europeia: **ETA-15/0539; 2025-11-20**  
Organismo de Avaliação Técnica: **DIBt- Deutsches Institut für Bautechnik**  
Organismo(s) notificado(s): **2873 TU Darmstadt**
7. Desempenho(s) declarado(s):  
**Resistência mecânica e estabilidade (BWR 1)**  
**Resistência característica sob ação estática e quase estática:**  
Tensão de aderência de armaduras pós-instaladas: Anexo C1  
Fator de redução: Anexo C1  
Fator de amplificação para comprimento mínimo de ancoragem: Anexo C1  
Resistência característica à rotura do aço sob tensão de tração do varão: NPD  
  
**Resistência característica sob ação sísmica:**  
Tensão de aderência sob ação sísmica, fator de eficiência de aderência sísmico: NPD  
Recobrimento mínimo sob ação sísmica: NPD  
  
**Segurança em caso de incêndio (BWR 2)**  
Reação ao fogo: Classe (A1)  
  
**Resistência ao fogo:**  
Tensão de aderência para temperaturas para armaduras pós-instaladas avaliadas para 50 anos: NPD  
Tensão de aderência para temperaturas para armaduras pós-instaladas avaliadas para 100 anos: NPD  
Resistência característica à rotura do aço sob tensão de tração do varão sob exposição ao fogo: NPD
8. Documentação Técnica Adequada e/ou Documentação Técnica Específica: **-**

O desempenho do produto identificado acima está em conformidade com o conjunto de desempenhos declarados. A presente declaração de desempenho é emitida, em conformidade com o Regulamento (UE) n.º 305/2011, sob a exclusiva responsabilidade do fabricante identificado acima.

Assinado por e em nome do fabricante por:



Dr. Ronald Mihala, Diretor Administrativo de Unidades de Negócios e Engenharia  
Tumlingen, 2025-12-08



Dieter Pfaff, Chefe da Federação Internacional de Produção e Gestão da Qualidade

Este DoP foi preparado em diferentes línguas. Em caso de litígio sobre a interpretação, a versão em inglês prevalecerá sempre.

O Anexo inclui informações voluntárias e complementares em inglês que excedem os requisitos legais (linguisticamente especificados).

Translation guidance Essential Characteristics and Performance Parameters for Annexes

**Guia de tradução das Características Essenciais e Parâmetros de Desempenho para os Anexos**

Mechanical resistance and stability (BWR 1)		
Resistência mecânica e estabilidade (BWR 1)		
	Characteristic resistance under static and quasi-static loading: <b>Resistência característica sob ação estática e quase estática:</b>	
1	Bond strength of post-installed rebar: <b>Tensão de aderência de armaduras pós-instaladas:</b>	$f_{bd,PIR}$ [N/mm <sup>2</sup> ], $f_{bd,PIR,100y}$ [N/mm <sup>2</sup> ]
2	Bond efficiency factor: <b>Fator de redução:</b>	$k_b$ [-], $k_{b,100y}$ [-]
3	Amplification factor for minimum anchorage length: <b>Fator de amplificação para comprimento mínimo de ancoragem:</b>	$\alpha_{lb}$ [-], $\alpha_{lb,100y}$ [-]
4	Characteristic resistance to steel failure for rebar tension anchors: <b>Resistência característica à rotura do aço sob tensão de tração do varão:</b>	$N_{Rk,s}$ [kN]
	Characteristic resistance under seismic loading: <b>Resistência característica sob ação sísmica:</b>	
5	Bond strength under seismic loading, Seismic bond efficiency factor: <b>Tensão de aderência sob ação sísmica, fator de eficiência de aderência sísmico:</b>	$f_{bd,PIR,seis}$ [N/mm <sup>2</sup> ], $k_{b,seis}$ [-], $f_{bd,PIR,seis,100y}$ [N/mm <sup>2</sup> ], $k_{b,seis,100y}$ [-]
6	Minimum concrete cover under seismic loading: <b>Recobrimento mínimo sob ação sísmica:</b>	$c_{min,seis}$ [mm]
Safety in case of fire (BWR 2)		
Segurança em caso de incêndio (BWR 2)		
7	Reaction to fire: <b>Reação ao fogo:</b>	Class
	Resistance to fire: <b>Resistência ao fogo:</b>	
8	Bond strength at increased temperature for post-installed rebar assessed for 50 years: <b>Tensão de aderência para temperaturas para armaduras pós-instaladas avaliadas para 50 anos:</b>	$f_{bd,fi}(\theta)$ [N/mm <sup>2</sup> ], $k_{fi}(\theta)$ [-], $\theta_{max}$ [°C]
9	Bond strength at increased temperature for post-installed rebar assessed for 100 years: <b>Tensão de aderência para temperaturas para armaduras pós-instaladas avaliadas para 100 anos:</b>	$f_{bd,fi,100y}(\theta)$ [N/mm <sup>2</sup> ], $k_{fi,100y}(\theta)$ [-], $\theta_{max}$ [°C]
10	Characteristic resistance to steel failure for rebar tension anchors under fire exposure: <b>Resistência característica à rotura do aço sob tensão de tração do varão sob exposição ao fogo:</b>	$N_{Rk,s,fi}$ [kN]

## Specific Part

### 1 Technical description of the product

The subject of this European Technical Assessment is the post-installed connection, by anchoring or overlap connection joint, of reinforcing bars (rebars) in existing structures made of normal weight concrete, using the "Rebar connection with injection system FIS VL" in accordance with the regulations for reinforced concrete construction.

Reinforcing bars made of steel with a diameter  $\phi$  from 10 to 25 mm according to Annex A and injection mortar FIS VL are used for rebar connections. The rebar is placed into a drilled hole filled with injection mortar and is anchored via the bond between rebar, injection mortar and concrete.

The product description is given in Annex A.

### 2 Specification of the intended use in accordance with the applicable European assessment Document

The performances given in Section 3 are only valid if the rebar connection is used in compliance with the specifications and conditions given in Annex B.

The verifications and assessment methods on which this European Technical Assessment is based lead to the assumption of a working life of the rebar connections of at least 50 years. The indications given on the working life cannot be interpreted as a guarantee given by the producer, but are to be regarded only as a means for choosing the right products in relation to the expected economically reasonable working life of the works.

### 3 Performance of the product and references to the methods used for its assessment

#### 3.1 Mechanical resistance and stability (BWR 1)

Essential characteristic	Performance
Characteristic resistance under static and quasi-static loading	See Annex C1
Characteristic resistance under seismic loading	No performance assessed

#### 3.2 Safety in case of fire (BWR 2)

Essential characteristic	Performance
Reaction to fire	Class A1
Resistance to fire	No performance assessed

### 4 Assessment and verification of constancy of performance (AVCP) system applied, with reference to its legal base

In accordance with European Assessment Document EAD No. 330087-01-0601, the applicable European legal act is: [96/582/EC].

The system to be applied is: 1

# Installation conditions and application examples reinforcing bars, part 1

**Figure A1.1:**

Overlap joint with existing reinforcement for rebar connections of slabs and beams

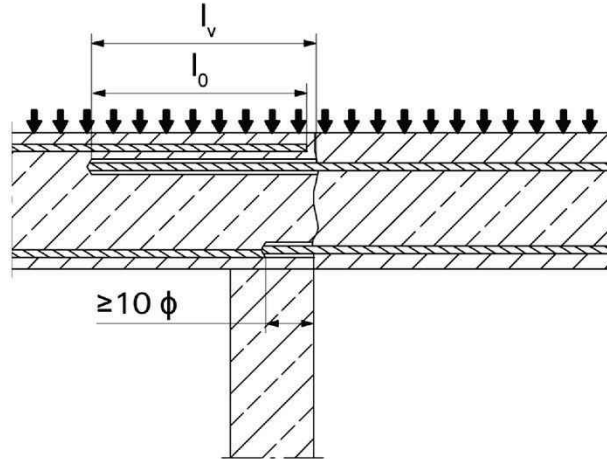

**Figure A1.2:**

Overlap joint with existing reinforcement at a foundation of a column or wall where the rebar is stressed

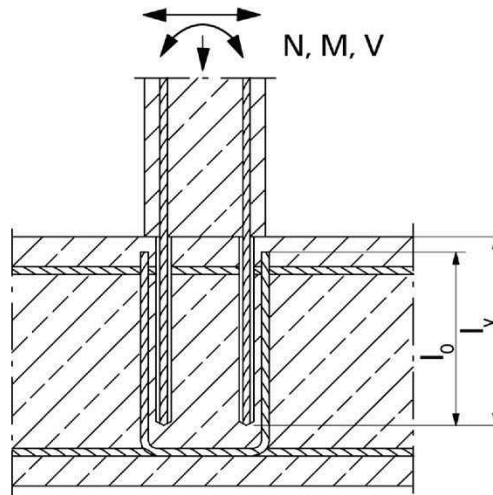

**Figure A1.3:**

End anchoring of slabs or beams (e.g. designed as simply supported)

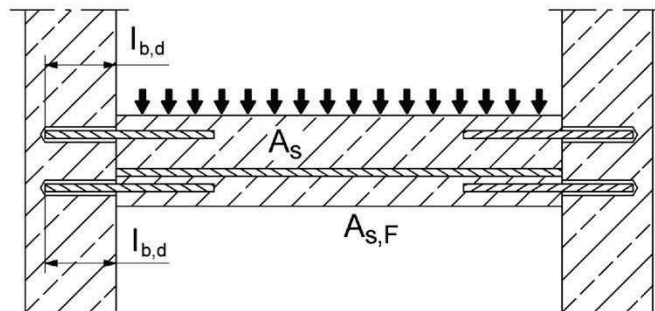

Figures not to scale

Rebar connection with injection system FIS VL

**Product description**

Installation conditions and application examples reinforcing bars, part 1

**Annex A1**

Appendix 2 / 16

## Installation conditions and application examples reinforcing bars, part 2

**Figure A2.1:**

Rebar connection for stressed primarily in compression

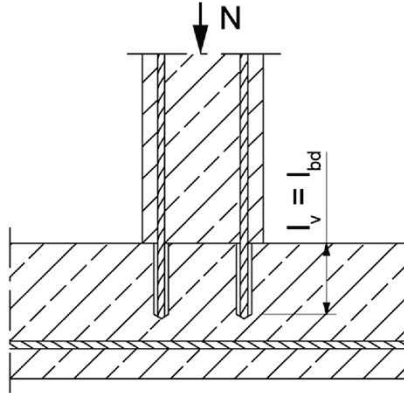

**Figure A2.2:**

Anchoring of reinforcement to cover the enveloped line of acting tensile force in the bending member

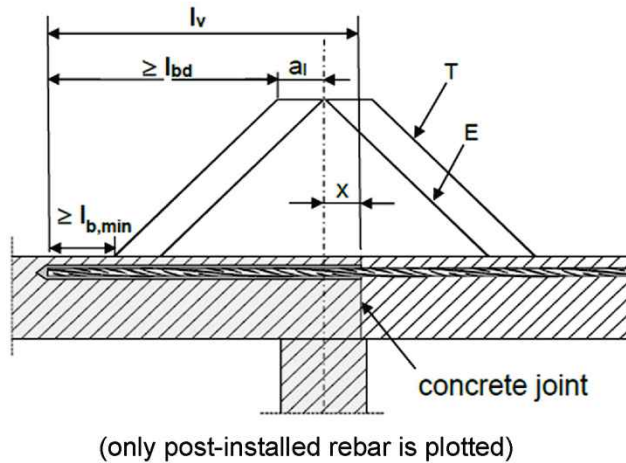

Key to Figure

- T Acting tensile force
- E Envelope of  $M_{ed} / z + N_{ed}$  (see EN 1992-1-1:2011)
- x Distance between the theoretical point of support and concrete joint

Note to **figure A1.1 to A1.3** and **figure A2.1 to A2.2**

In the figures no traverse reinforcement is plotted, the traverse reinforcement as required by EN 1992-1-1:2011 shall be present.

The shear transfer between old and new concrete shall be designed according to EN 1992-1-1:2011. Preparation of joints according to **Annex B3** of this document

Figures not to scale

Rebar connection with injection system FIS VL

**Product description**

Installation conditions and application examples reinforcing bars, part 2

**Annex A2**

Appendix 3 / 16

## Overview system components

**Injection cartridge (shuttle cartridge) with sealing cap; Sizes: 360 ml, 825 ml**

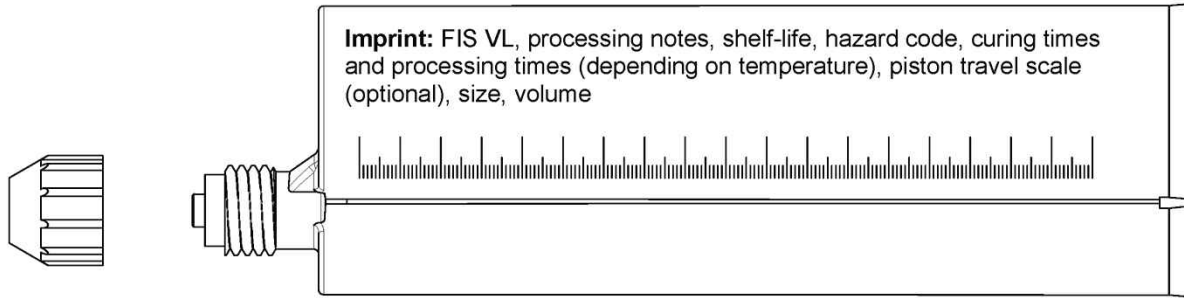

**Injection cartridge (coaxial cartridge) with sealing cap; Sizes: 300 ml, 380 ml, 400 ml, 410 ml**

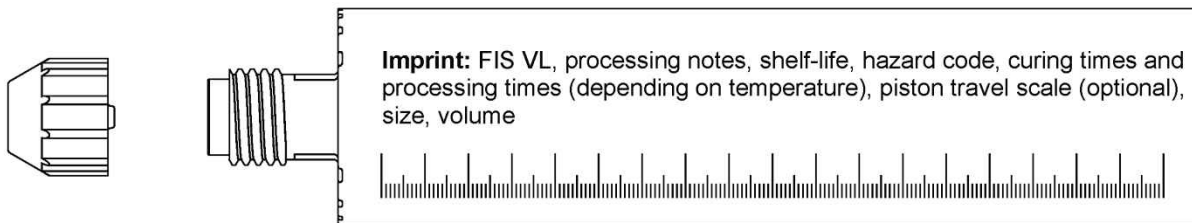

**Static mixer FIS MR Plus for injection cartridges up to 410 ml**

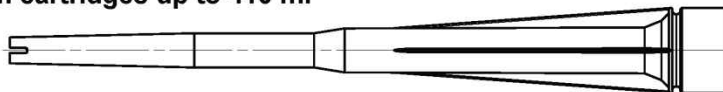

**Static mixer FIS JMR for injection cartridges 825 ml**

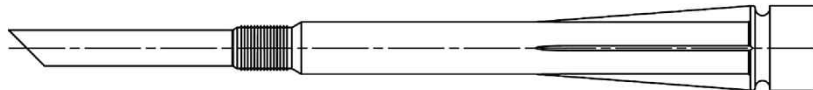

**Injection adapter and extension tube Ø 9 for static mixer FIS MR Plus;  
Injection adapter and extension tube Ø 9 or Ø 15 for static mixer FIS JMR**

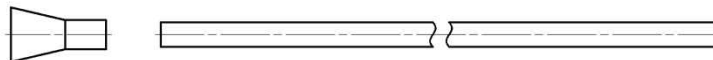

**Reinforcing bar (rebar) Sizes:  $\phi 10$ ,  $\phi 12$ ,  $\phi 14$ ,  $\phi 16$ ,  $\phi 20$ ,  $\phi 25$**



**Blow out pump AB G**



**Compressed-air cleaning tool AB P with fischer compressed-air nozzle**

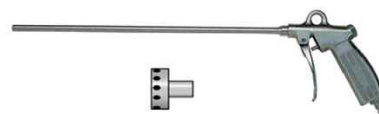

Figures not to scale

**Rebar connection with injection system FIS VL**

### Product description

Overview system components; Injection mortar, static mixer, injection adapter, reinforcing bar

**Annex A3**

Appendix 4 / 16

## Properties of reinforcing bars (rebar)

Figure A4.1:



- The minimum value of related rib area  $f_{R,min}$  according to EN 1992-1-1:2011
- The maximum outer rebar diameter over the ribs shall be:
  - The nominal diameter of the bar with rib  $\phi + 2 \cdot h$  ( $h \leq 0,07 \cdot \phi$ )
  - ( $\phi$ : Nominal diameter of the bar;  $h_{rib}$  = rib height of the bar)

Table A4.1: Installation conditions for rebars

Nominal diameter of the bar		$\phi$	10 <sup>1)</sup>		12 <sup>1)</sup>		14	16	20	25 <sup>1)</sup>	
Nominal drill hole diameter	$d_0$	[mm]	12	14	14	16	18	20	25	30	35
Drill hole depth	$h_0$		$h_0 = l_v$								
Effective embedment depth	$l_v$		acc. to static calculation								
Minimum thickness of concrete member	$h_{min}$		$l_v + 30$ ( $\geq 100$ )			$l_v + 2d_0$					

<sup>1)</sup> Both drill hole diameters can be used.

Table A4.2: Materials of rebars

Designation	Reinforcing bar (rebar)
Reinforcing bar EN 1992-1-1:2011, Annex C	Bars and de-coiled rods class B or C with $f_{yk}$ and $k$ according to NDP or NCI of EN 1992-1-1/NA $f_{uk} = f_{tk} = k \cdot f_{yk}$

Figures not to scale



Rebar connection with injection system FIS VL

**Product description**  
Properties and materials of reinforcing bars (rebar)

**Annex A4**  
Appendix 5 / 16

# Specifications of intended use part 1

**Table B1.1:** Overview use and performance categories

Anchorages subject to		<b>FIS VL with ...</b>	
		Reinforcing bar 	
Hammer drilling or compressed air drilling with standard drill bit 		all sizes	
Hammer drilling with hollow drill bit  (fischer "FHD" & "FHD II", Heller "Duster Expert", Bosch "Speed Clean", Hilti "TE-CD, TE-YD")		Nominal drill bit diameter ( $d_0$ ) 12 mm to 35 mm	
Use category I1	dry or wet concrete	all sizes	
Characteristic resistance under static and quasi static loading, in	uncracked concrete	all sizes	Tables: C1.1 C1.2 C1.3
	cracked concrete		
Characteristic resistance under seismic loading		_1)	
Installation direction		D3 (downward and horizontal and upwards (e.g. overhead))	
Installation temperature		$T_{i,min} = 0\text{ °C}$ to $T_{i,max} = +40\text{ °C}$	
Service temperature	Temperature range	-40 °C to +80 °C	(max. short term temperature +80 °C; max long term temperature +50 °C)
Resistance to fire		_1)	

<sup>1)</sup> No performance assessed

Rebar connection with injection system FIS VL

**Intended use**  
Specifications part 1

**Annex B1**  
Appendix 6 / 16

## Specifications of intended use part 2

### Anchorage subject to:

- Static and quasi-static loading: reinforcing bar (rebar) size 10 mm to 25 mm;

### Base materials:

- Compacted reinforced or unreinforced normal weight concrete without fibres according to EN 206:2013+A2:2021
- Concrete strength classes C20/25 to C35/45 according to EN 206:2013+A2:2021
- Maximum chloride content of 0,40 % (CL 0.40) related to the cement content according to EN 206:2013+A2:2021
- Non-carbonated concrete

Note: In case of a carbonated surface of the existing concrete structure the carbonated layer shall be removed in the area of the post-installed rebar connection with a diameter of  $\phi + 60$  mm prior to the installation of the new rebar. The depth of concrete to be removed shall correspond to at least the minimum concrete cover in accordance with EN 1992-1-1:2011. The foregoing may be neglected if building components are new and not carbonated and if building components are in dry conditions.

### Design:

- The structural design according to EN 1992-1-1:2011, EN 1992-1-2:2011 and Annex B3 and B4 are conducted under responsibility of a designer experienced in the field of anchorages and concrete works.
- Verifiable calculation notes and drawings are prepared taking account of the forces to be transmitted.
- The actual position of the reinforcement in the existing structure shall be determined on the basis of the construction documentation and taken into account when designing.

### Installation:

- The installation of post-installed rebar shall be done only by suitable trained installer and under Supervision on site; the conditions under which an installer may be considered as suitable trained and the conditions for Supervision on site are up to the Member States in which the installation is done.
- Check the position of the existing rebars (if the position of existing rebars is not known, it shall be determined using a rebar detector suitable for this purpose as well as on the basis of the construction documentation and then marked on the building component for the overlap joint).

Rebar connection with injection system FIS VL

**Intended use**  
Specifications part 2

**Annex B2**  
Appendix 7 / 16

# General construction rules for post-installed rebars

**Figure B3.1:**

- Only tension forces in the axis of the rebar may be transmitted.
- The transfer of shear forces between new concrete and existing structure shall be designed additionally according to EN 1992-1-1:2011.
- The joints for concreting must be roughened to at least such an extent that aggregate protrude.

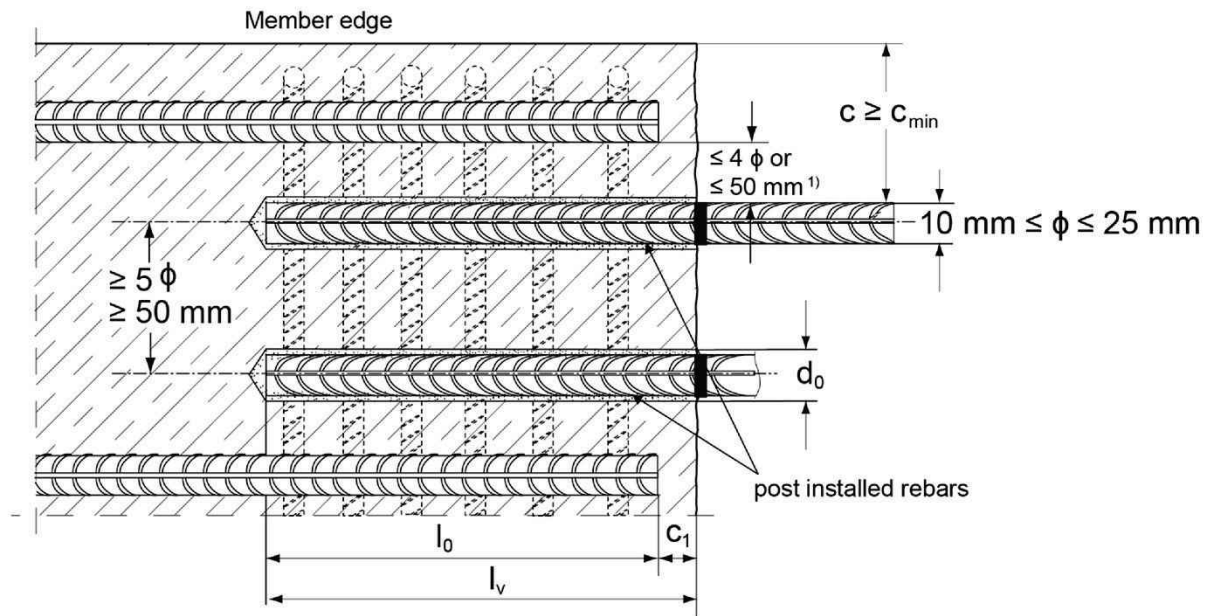

<sup>1)</sup> If the clear distance between lapped bars exceeds  $4 \phi$  or 50 mm then the lap length shall be increased by the difference between the clear bar distance and the smaller  $4 \phi$  or 50 mm.

- c concrete cover of post-installed rebar
- c<sub>1</sub> concrete cover at end-face of existing rebar
- c<sub>min</sub> minimum concrete cover according to **Table B4.1** and to EN 1992-1-1:2011, Section 4.4.1.2
- φ nominal diameter of reinforcing bar
- l<sub>0</sub> lap length, according to EN 1992-1-1:2011 for static loading
- l<sub>v</sub> effective embedment depth,  $\geq l_0 + c_1$
- d<sub>0</sub> nominal drill bit diameter, see **Annex B5**

Figures not to scale

Rebar connection with injection system FIS VL

**Intended use**  
General construction rules for post-installed rebars

**Annex B3**  
Appendix 8 / 16

**Table B4.1: Minimum concrete cover  $c_{min}^{1)}$  depending of the drilling method and the drilling tolerance**

Drilling method	nominal diameter of reinforcing bar $\phi$ [mm]	Minimum concrete cover $c_{min}$	
		Without drilling aid [mm]	With drilling aid [mm]
Hammer drilling with standard drill bit or hollow drill bit	< 25	$30 \text{ mm} + 0,06 l_v \geq 2 \phi$	$30 \text{ mm} + 0,02 l_v \geq 2 \phi$
	$\geq 25$	$40 \text{ mm} + 0,06 l_v \geq 2 \phi$	$40 \text{ mm} + 0,02 l_v \geq 2 \phi$
Compressed air drilling	< 25	$50 \text{ mm} + 0,08 l_v$	$50 \text{ mm} + 0,02 l_v$
	$\geq 25$	$60 \text{ mm} + 0,08 l_v \geq 2 \phi$	$60 \text{ mm} + 0,02 l_v \geq 2 \phi$

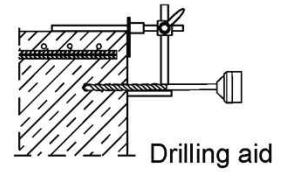

<sup>1)</sup> See Annex B3, figure B3.1

Note: The minimum concrete cover as specified in EN 1992-1-1:2011 must be observed.

**Table B4.2: Dispensers and cartridge sizes corresponding to maximum embedment depth  $l_{v,max}$**

reinforcing bars (rebar) $\phi$ [mm]	Manual dispenser	Accu and pneumatic dispenser (small)	Accu and pneumatic dispenser (large)
	Cartridge size		
	< 500 ml $l_{v,max} / l_{e,ges,max}$ [mm]		> 500 ml $l_{v,max} / l_{e,ges,max}$ [mm]
10	1000	1000	1800
12		1200	
14		1500	
16		1300	
20	700	1000	2000
25			

**Table B4.3: Conditions for use static mixer without an extension tube**

Nominal drill hole diameter $d_0$	[mm]	10	12	14	16	18	20	24	25	30	35
		Drill hole depth $h_0$ by FIS MR Plus using FIS JMR		$\leq 90$	$\leq 120$	$\leq 140$	$\leq 150$	$\leq 160$	$\leq 190$	$\leq 210$	
		-	-	$\leq 90$	$\leq 160$	$\leq 180$	$\leq 190$	$\leq 220$		$\leq 250$	

Figures not to scale

Rebar connection with injection system FIS VL

**Intended use**  
Minimum concrete cover;  
dispenser and cartridge sizes corresponding to maximum embedment depth

**Annex B4**  
Appendix 9 / 16

**Table B5.1: Working times  $t_{work}$  and curing times  $t_{cure}$** 

Temperature in the anchorage base [°C]	Maximum working time <sup>1)</sup> $t_{work}$ <b>FIS VL</b>	Minimum curing time <sup>2)</sup> $t_{cure}$ <b>FIS VL</b>
0 to 5 <sup>3)</sup>	13 min	3 h
> 5 to 10 <sup>3)</sup>	9 min	90 min
> 10 to 20	5 min	60 min
> 20 to 30	4 min	45 min
> 30 to 40 <sup>4)</sup>	2 min	35 min

<sup>1)</sup> Maximum time from the beginning of the injection to rebar setting and positioning.

<sup>2)</sup> For wet concrete the curing time must be doubled.

<sup>3)</sup> If the temperature in the concrete falls below 10 °C the cartridge must be warmed up to +15 °C.

<sup>4)</sup> If the temperature in the concrete exceeds 30 °C the cartridge must be cooled down to +15 °C up to 20 °C.

**Table B5.2: Installation tools for drilling and cleaning the bore hole and injection of the mortar**

reinforcing bars (rebar)  $\phi$ [mm]	Drilling and cleaning				Injection	
	Nominal drill bit diameter  $d_0$ [mm]	Diameter of cutting edge  $d_{cut}$ [mm]	Steel brush diameter  $d_b$ [mm]	Diameter of fischer compressed air nozzle  [mm]	Diameter of extension tube  [mm]	Injection adapter  [colour]
10 <sup>1)</sup>	12	≤ 12,50	12,5	11	9	nature
	14	≤ 14,50	15			blue
12 <sup>1)</sup>	14	≤ 14,50	15	15	9 or 15	red
	16	≤ 16,50	17			yellow
14	18	≤ 18,50	19	19	9 or 15	green
16	20	≤ 20,55	21,5			black
20	25	≤ 25,55	26,5	28	9 or 15	grey
25 <sup>1)</sup>	30	≤ 30,55	32			brown
		35	≤ 35,70	37		

<sup>1)</sup> Both drill bit diameters can be used.

Rebar connection with injection system FIS VL

**Intended use**

Working times and curing times;

Installation tools for drilling and cleaning the bore hole and injection of the mortar

**Annex B5**

Appendix 10 / 16

## Safety regulations



Review the Safety Data Sheet (SDS) before use for proper and safe handling!  
Wear well-fitting protective goggles and protective gloves when working with mortar FIS VL.  
Important: Observe the instructions for use provided with each cartridge.

## Installation instruction part 1; Installation with FIS VL

### Hole drilling

Note: Before drilling, remove carbonized concrete; clean contact areas (see **Annex B2**)  
In case of aborted drill holes the drill hole shall be filled with mortar.

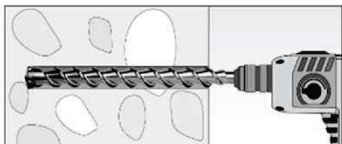
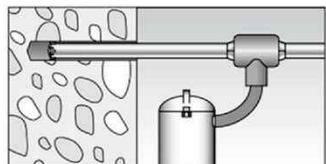
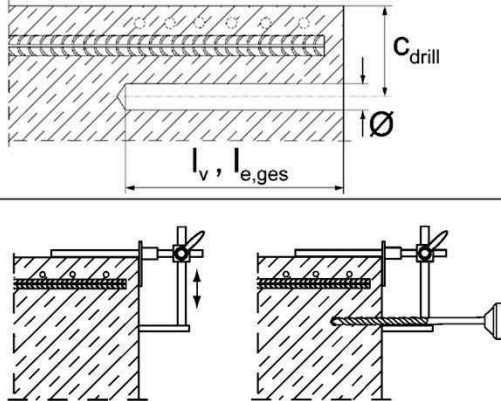
1a	<p><b>Hammer drilling or compressed air drilling</b></p> 	<p>Drill the hole to the required embedment depth using a hammer drill with carbide drill bit set in rotation hammer mode or a pneumatic drill. Drill bit sizes see <b>Table B5.2</b>.</p>
1b	<p><b>Hammer drilling with hollow drill bit</b></p> 	<p>Drill the hole to the required embedment depth using a hammer drill with hollow drill bit in rotation hammer mode. Dust extraction conditions see drill hole cleaning <b>Annex B7</b>. Drill bit sizes see <b>Table B5.2</b>.</p>
2		<p>Measure and control concrete cover <math>c</math> (<math>c_{drill} = c + \varnothing / 2</math>) Drill parallel to surface edge and to existing rebar. Where applicable use drilling aid.</p> <p>For holes <math>l_v &gt; 20</math> cm use drilling aid. Three different options can be considered: A) drilling aid B) Slat or spirit level C) Visual check</p> <p>Minimum concrete cover <math>c_{min}</math> see <b>Table B4.1</b>.</p>

## Rebar connection with injection system FIS VL

**Intended use**  
Safety regulations; Installation instruction part 1, hole drilling

**Annex B6**  
Appendix 11 / 16

# Installation instruction part 2; Installation with FIS VL

## Drill hole cleaning

### Hammer or compressed air drilling

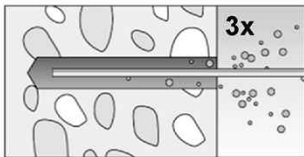

Clean the drill hole:  
For  $d_0 < 18$  mm and depths  $l_v$  resp.  
 $l_{e,ges} \leq 12 \cdot \phi$   
blow out the hole three times by hand.

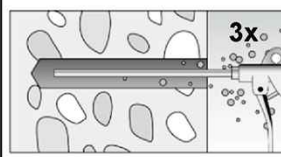

For  $d_0 > 18$  mm and depths  $l_v$  resp.  
 $l_{e,ges} > 12 \cdot \phi$  blow out the hole three times with oil-free compressed air ( $p \geq 6$  bar). Use suitable compressed-air nozzle (see **Table B5.2**).

3a

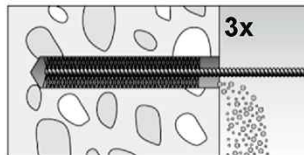

Brush drill hole three times; for drill hole diameters  $d_0 \geq 30$  mm attach brush to a power tool and brush hole with a speed of max. 550 revolutions per minute. For deep holes a brush extension is mandatory. Use suitable brushes (see **Table B5.2**).

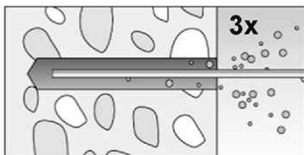

Clean the drill hole:  
For  $d_0 < 18$  mm and depths  $l_v$  resp.  
 $l_{e,ges} \leq 12 \cdot \phi$   
blow out the hole three times by hand.

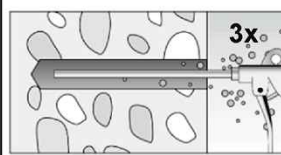

For  $d_0 > 18$  mm and depths  $l_v$  resp.  
 $l_{e,ges} > 12 \cdot \phi$  blow out the hole three times with oil-free compressed air ( $p \geq 6$  bar) Use suitable compressed-air nozzle (see **Table B5.2**).

### Hammer drilling with hollow drill bit



3b

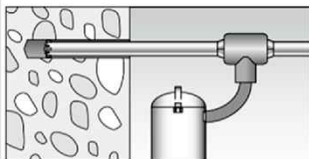

Use a suitable dust extraction system, e. g. fischer FVC 35 M or a comparable dust extraction system with equivalent performance data.  
Drill the hole with hollow drill bit. The dust extraction system has to extract the drill dust nonstop during the drilling process and must be adjusted to maximum power.  
No further drill hole cleaning necessary.

Rebar connection with injection system FIS VL

**Intended use**

Installation instruction part 2, drill hole cleaning

**Annex B7**

Appendix 12 / 16

# Installation instruction part 3; Installation with FIS VL

## reinforcing bars (rebar) and cartridge preparation

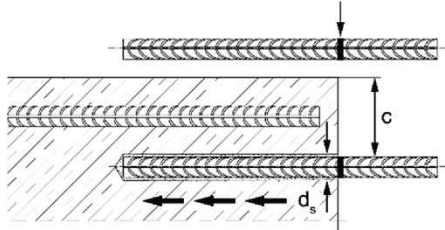
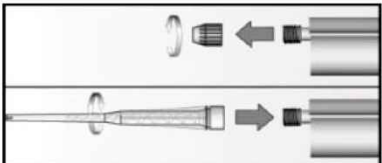
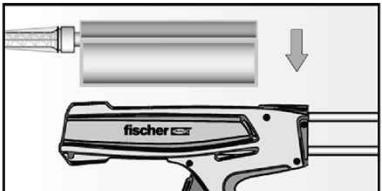
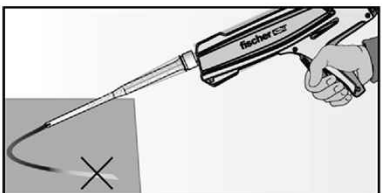
4		<p>Before use, make asure that the rebar is dry and free of oil or other residue. Mark the embedment depth <math>l_v</math> (e.g. with tape) Insert rebar in borehole, to verify drill hole depth and setting depth <math>l_v</math> resp. <math>l_{e,ges}</math>.</p>
5		<p>Twist off the sealing cap Twist on the static mixer (the spiral in the static mixer must be clearly visible).</p>
6		<p>Place the cartridge into a suitable dispenser.</p>
7		<p>Press out approximately 10 cm of mortar until the resin is permanently grey in colour. Mortar which is not grey in colour will not cure and must be disposed.</p>

Rebar connection with injection system FIS VL

**Intended use**  
Installation instruction part 3,  
reinforcing bars (rebar) and cartridge preparation

**Annex B8**  
Appendix 13 / 16

## Installation instruction part 4; Installation with FIS VL

### Injection of the mortar without extension tube

8a

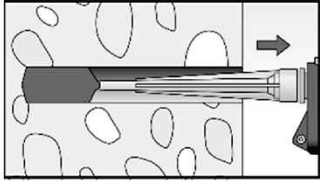

Inject the mortar from the back of the hole towards the front and slowly withdraw the static mixer step by step with each trigger pull. Avoid bubbles.  
Fill holes approximately 2/3 full, to ensure that the annular gap between the rebar and the concrete will be completely filled with adhesive over the entire embedment length.  
The conditions for mortar injection without extension tube can be found in **Table B4.3**.

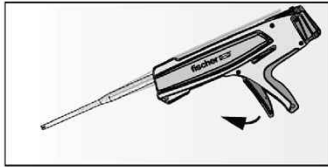

After injecting, release the dispenser. This will prevent further mortar discharge from the static mixer.

### Injection of the mortar with extension tube

8b

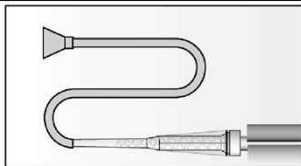

Assemble static mixer FIS MR Plus or FIS JMR, extension tube and appropriate injection adapter (see **Table B5.2**).

Mortar level mark

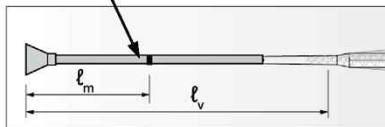

Mark the required mortar level  $l_m$  and embedment depth  $l_v$  resp.  $l_{e,ges}$  with tape or marker on the injection extension tube.

a) Estimation:

$$l_m = \frac{1}{3} \cdot l_v \text{ resp. } l_m = \frac{1}{3} \cdot l_{e,ges} \text{ [mm]}$$

b) Precise equation for optimum mortar volume:

$$l_m = l_v \text{ resp. } l_{e,ges} \left( \left( 1,2 \cdot \frac{d_s^2}{d_0^2} - 0,2 \right) \right) \text{ [mm]}$$

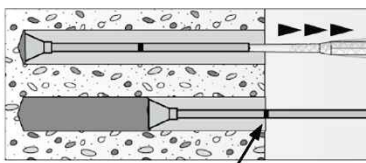

Mortar level mark

Insert injection adapter to back of the hole. Begin injection allowing the pressure of the injected adhesive mortar to push the injection adapter towards the front of the hole. Do not actively pull out!  
Fill holes approximately 2/3 full, to ensure that the annular gap between the rebar and the concrete will be completely filled with adhesive over the embedment length.  
When using an injection adapter continue injection until the mortar level mark  $l_m$  becomes visible.  
Maximum embedment depth see **Table B4.2**.

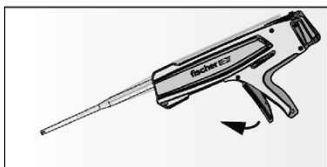

After injecting, release the dispenser. This will prevent further mortar discharge from static mixer.

## Rebar connection with injection system FIS VL

### Intended use

Installation instruction part 4, mortar injection

## Annex B9

Appendix 14 / 16

# Installation instruction part 5; Installation with FIS VL

## Insert rebar

9		<p>Insert the rebar slowly twisted into the borehole until the embedment mark is reached.                  Recommendation:                  Rotation back and forth of the reinforcement bar makes pushing easy.</p>
10		<p>For overhead installation, support the rebar and secure it from falling till mortar started to harden, e.g. using wedges.</p>
11		<p>After installing the rebar the annular gap must be completely filled with mortar.</p> <p>Proper installation</p> <ul style="list-style-type: none"> <li>• Desired embedment depth is reached <math>l_v</math>, resp. <math>l_{e,ges}</math>: embedment mark at concrete surface</li> <li>• Excess mortar flows out of the borehole after the rebar has been fully inserted up to the embedment mark.</li> </ul>
12		<p>Observe the working time "<math>t_{work}</math>" (see Table B5.1), which varies according to temperature of base material. Minor adjustments to the rebar position may be performed during the working time</p> <p>Full load may be applied only after the curing time "<math>t_{cure}</math>" has elapsed (see Table B5.1).</p>

Rebar connection with injection system FIS VL

**Intended use**  
 Installation instruction part 5, insert rebar

**Annex B10**  
 Appendix 15 / 16

## Minimum anchorage length and minimum lap length

The minimum anchorage length  $l_{b,min}$  and the minimum lap length  $l_{0,min}$  according to EN 1992-1-1:2011 shall be multiplied by the relevant amplification factor  $\alpha_{lb}$  according to **Table C1.1**.

**Table C1.1:** Amplification factor  $\alpha_{lb}$  related to concrete strength class and drilling method

### Hammer drilling, hollow drilling and compressed air drilling

Rebar $\phi$ [mm]	Amplification factor $\alpha_{lb}$			
	Concrete strength class			
	C20/25	C25/30	C30/37	C35/45
10 to 25	1,0			

**Table C1.2:** Bond efficiency factor  $k_b$  related to concrete strength class and drilling method

### Hammer drilling, hollow drilling and compressed air drilling

Rebar $\phi$ [mm]	Bond efficiency factor $k_b$			
	Concrete strength class			
	C20/25	C25/30	C30/37	C35/45
10 to 25	1,0			

**Table C1.3:** Design values of the bond strength  $f_{bd,PIR}$  in N/mm<sup>2</sup> related to concrete strength class and drilling method for good bond conditions

$$f_{bd,PIR} = k_b \cdot f_{bd}$$

$f_{bd}$ : Design value of the bond strength in N/mm<sup>2</sup> considering the concrete strength classes and the rebar diameter for good bond condition (for all other bond conditions multiply the values by  $\eta_1 = 0,7$ ) and recommended partial factor  $\gamma_c = 1,5$  according to EN 1992-1-1: 2011

$k_b$ : Bond efficiency factor according to **Table C1.2**

### Hammer drilling, hollow drilling and compressed air drilling

Rebar $\phi$ [mm]	Bond strength $f_{bd,PIR}$ [N/mm <sup>2</sup> ]			
	Concrete strength class			
	C20/25	C25/30	C30/37	C35/45
10 to 25	2,3	2,7	3,0	3,4

Rebar connection with injection system FIS VL

#### Performance

Amplification factor  $\alpha_{lb}$ , bond efficiency factor  $k_b$ , design values of the bond strength  $f_{bd,PIR}$

**Annex C1**

Appendix 16 / 16