

## DECLARAÇÃO DE DESEMPENHO

### DoP 0331

para sistema de injeção fischer FIS V Plus (Argamassa para conexões de armaduras pós-instaladas)

PT

- Código de identificação único do produto-tipo:** DoP 0331
- Utilização(ões) prevista(s):** Sistema para conexão de armaduras pós-instaladas com argamassa para uso em betão, Ver anexos, especialmente anexos B1-B11.
- Fabricante:** fischerwerke GmbH & Co. KG, Otto-Hahn-Straße 15, 79211 Denzlingen, Alemanha
- Representante autorizado:** -
- Sistema(s) de avaliação e verificação da regularidade do desempenho (AVCP):** 1
- Documento de Avaliação Europeu:** EAD 330087-01-0601 Edition 06/2021  
**Avaliação Técnica Europeia:** ETA-20/0728; 2022-12-16  
**Organismo de Avaliação Técnica:** DIBt- Deutsches Institut für Bautechnik  
**Organismo(s) notificado(s):** 2873 TU Darmstadt

#### 7. Desempenho(s) declarado(s):

##### **Resistência mecânica e estabilidade (BWR 1)**

###### **Resistência característica sob ação estática e quase estática:**

Tensão de aderência de armaduras pós-instaladas: Anexo C1

Fator de redução: Anexo C1

Fator de amplificação para comprimento mínimo de ancoragem: Anexo C1

Resistência característica à rotura do aço sob tensão de tração do varão: Anexo C2

$f_{bd,PIR,100y}$ = NPD

$k_{b,100y}$ = NPD

$\alpha_{lb,100y}$ = NPD

###### **Resistência característica sob ação sísmica:**

Tensão de aderência sob ação sísmica, fator de eficiência de aderência sísmico: NPD

Recobrimento mínimo sob ação sísmica: NPD

##### **Segurança em caso de incêndio (BWR 2)**

Reação ao fogo: Classe (A1)

###### **Resistência ao fogo:**

Tensão de aderência para temperaturas para armaduras pós-instaladas avaliadas para 50 anos: Anexo C3

Tensão de aderência para temperaturas para armaduras pós-instaladas avaliadas para 100 anos: NPD

Resistência característica à rotura do aço sob tensão de tração do varão sob exposição ao fogo: Anexo C2

- Documentação Técnica Adequada e/ou Documentação Técnica Específica:** -

O desempenho do produto identificado acima está em conformidade com o conjunto de desempenhos declarados. A presente declaração de desempenho é emitida, em conformidade com o Regulamento (UE) n.º 305/2011, sob a exclusiva responsabilidade do fabricante identificado acima.

Assinado por e em nome do fabricante por:



Dr.-Ing. Oliver Geibig, Diretor Administrativo de Unidades de Negócios e Engenharia  
Tumlingen, 2023-01-02

Jürgen Grün, Diretor Administrativo de Química e Qualidade

Este DoP foi preparado em diferentes línguas. Em caso de litígio sobre a interpretação, a versão em inglês prevalecerá sempre.

O Anexo inclui informações voluntárias e complementares em inglês que excedem os requisitos legais (linguisticamente especificados).

Translation guidance Essential Characteristics and Performance Parameters for Annexes

**Guia de tradução das Características Essenciais e Parâmetros de Desempenho para os Anexos**

Mechanical resistance and stability (BWR 1)		
Resistência mecânica e estabilidade (BWR 1)		
Characteristic resistance under static and quasi-static loading: <b>Resistência característica sob ação estática e quase estática:</b>		
1	Bond strength of post-installed rebar: <b>Tensão de aderência de armaduras pós-instaladas:</b>	$f_{bd,PIR}$ [N/mm <sup>2</sup> ], $f_{bd,PIR,100y}$ [N/mm <sup>2</sup> ]
2	Bond efficiency factor: <b>Fator de redução:</b>	$k_b$ [-], $k_{b,100y}$ [-]
3	Amplification factor for minimum anchorage length: <b>Fator de amplificação para comprimento mínimo de ancoragem:</b>	$\alpha_b$ [-], $\alpha_{b,100y}$ [-]
4	Characteristic resistance to steel failure for rebar tension anchors: <b>Resistência característica à rotura do aço sob tensão de tração do varão:</b>	$N_{RK,s}$ [kN]
Characteristic resistance under seismic loading: <b>Resistência característica sob ação sísmica:</b>		
5	Bond strength under seismic loading, Seismic bond efficiency factor: <b>Tensão de aderência sob ação sísmica, fator de eficiência de aderência sísmico:</b>	$f_{bd,PIR,seis}$ [N/mm <sup>2</sup> ], $k_{b,seis}$ [-], $f_{bd,PIR,seis,100y}$ [N/mm <sup>2</sup> ], $k_{b,seis,100y}$ [-]
6	Minimum concrete cover under seismic loading: <b>Recobrimento mínimo sob ação sísmica:</b>	$c_{min,seis}$ [mm]
Safety in case of fire (BWR 2)		
Segurança em caso de incêndio (BWR 2)		
7	Reaction to fire: <b>Reação ao fogo:</b>	Class
Resistance to fire: <b>Resistência ao fogo:</b>		
8	Bond strength at increased temperature for post-installed rebar assessed for 50 years: <b>Tensão de aderência para temperaturas para armaduras pós-instaladas avaliadas para 50 anos:</b>	$f_{bd,fi}(\theta)$ [N/mm <sup>2</sup> ], $k_{fi}(\theta)$ [-], $\theta_{max}$ [°C]
9	Bond strength at increased temperature for post-installed rebar assessed for 100 years: <b>Tensão de aderência para temperaturas para armaduras pós-instaladas avaliadas para 100 anos:</b>	$f_{bd,fi,100y}(\theta)$ [N/mm <sup>2</sup> ], $k_{fi,100y}(\theta)$ [-], $\theta_{max}$ [°C]
10	Characteristic resistance to steel failure for rebar tension anchors under fire exposure: <b>Resistência característica à rotura do aço sob tensão de tração do varão sob exposição ao fogo:</b>	$N_{RK,s,fi}$ [kN]

## Specific Part

### 1 Technical description of the product

The subject of this European Technical Assessment is the post-installed connection, by anchoring or overlap connection joint, of reinforcing bars (rebars) in existing structures made of normal weight concrete, using the "Rebar connection with injection system FIS V Plus" in accordance with the regulations for reinforced concrete construction.

Reinforcing bars made of steel with a diameter  $\phi$  from 8 to 28 mm or the fischer rebar anchor FRA or FRA HCR of sizes M12 to M24 according to Annex A and injection mortar FIS V Plus or FIS V Plus Low Speed are used for rebar connections. The rebar is placed into a drilled hole filled with injection mortar and is anchored via the bond between rebar, injection mortar and concrete.

The product description is given in Annex A.

### 2 Specification of the intended use in accordance with the applicable European assessment Document

The performances given in Section 3 are only valid if the rebar connection is used in compliance with the specifications and conditions given in Annex B.

The verifications and assessment methods on which this European Technical Assessment is based lead to the assumption of a working life of the rebar connections of at least 50 years. The indications given on the working life cannot be interpreted as a guarantee given by the producer, but are to be regarded only as a means for choosing the right products in relation to the expected economically reasonable working life of the works.

### 3 Performance of the product and references to the methods used for its assessment

#### 3.1 Mechanical resistance and stability (BWR 1)

Essential characteristic	Performance
Characteristic resistance under static and quasi-static loading	See Annex C 1 and C2
Characteristic resistance under seismic loading	No performance assessed

#### 3.2 Safety in case of fire (BWR 2)

Essential characteristic	Performance
Reaction to fire	Class A1
Resistance to fire	See Annex C 2 and C 3

### 4 Assessment and verification of constancy of performance (AVCP) system applied, with reference to its legal base

In accordance with European Assessment Document EAD No. 330087-01-0601, the applicable European legal act is: [96/582/EC].

The system to be applied is: 1

# Installation conditions and application examples reinforcing bars, part 1

**Figure A1.1:**

Overlap joint with existing reinforcement for rebar connections of slabs and beams

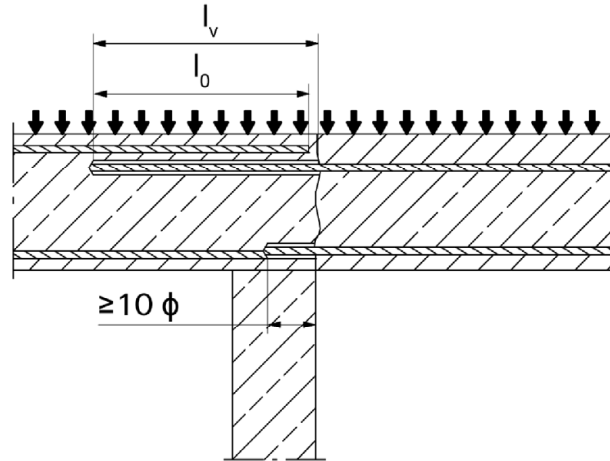

**Figure A1.2:**

Overlap joint with existing reinforcement at a foundation of a column or wall where the rebars are stressed

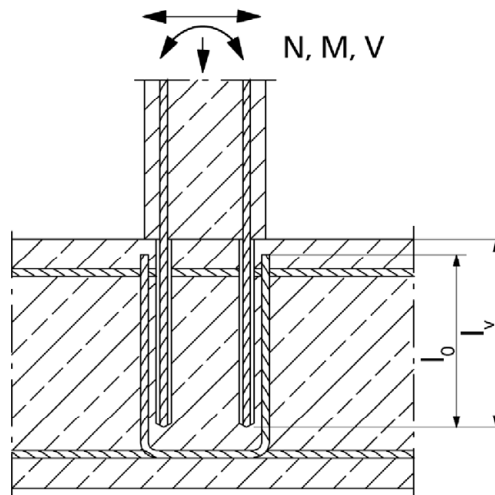

**Figure A1.3:**

End anchoring of slabs or beams (e.g. designed as simply supported)

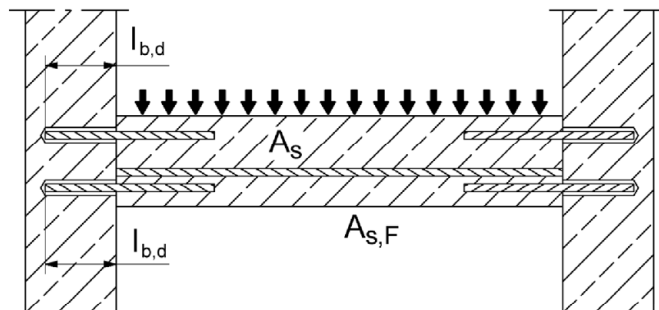

Figures not to scale

Rebar connection with injection system FIS V Plus

**Product description**

Installation conditions and application examples reinforcing bars, part 1

**Annex A 1**

Appendix 2 / 21

## Installation conditions and application examples reinforcing bars, part 2

**Figure A2.1:**

Rebar connection for stressed primarily in compression

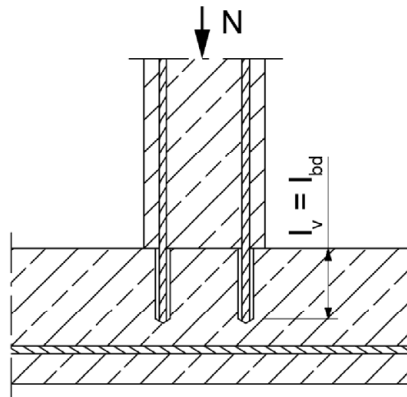

**Figure A2.2:**

Anchoring of reinforcement to cover the enveloped line of acting tensile force in the bending member

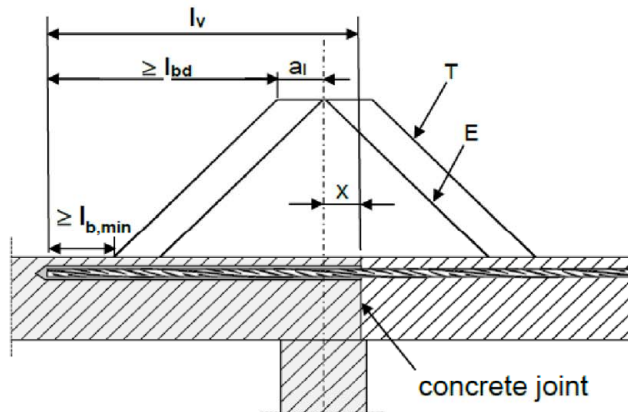

(only post-installed rebar is plotted)

Key to Figure

- T Acting tensile force
- E Envelope of  $M_{ed} / z + N_{ed}$  (see EN 1992-1-1:2011)
- x Distance between the theoretical point of support and concrete joint

Note to **figure A1.1 to A1.3** and **figure A2.1 to A2.2**

In the figures no traverse reinforcement is plotted, the traverse reinforcement as required by EN 1992-1-1:2011 shall be present.

The shear transfer between old and new concrete shall be designed according to EN 1992-1-1:2011

Preparation of joints according to **Annex B 3** of this document

Figures not to scale

Rebar connection with injection system FIS V Plus

**Product description**

Installation conditions and application examples reinforcing bars, part 2

**Annex A 2**

Appendix 3 / 21

# Installation conditions and application examples fischer rebar anchor FRA

**Figure A3.1:**

Lap to a foundation of a column under bending.

1. Shear lug (or fastener loaded in shear)
2. fischer rebar anchor FRA (tension only)
3. Existing stirrup / reinforcement for overlap (lap splice)
4. Slotted hole

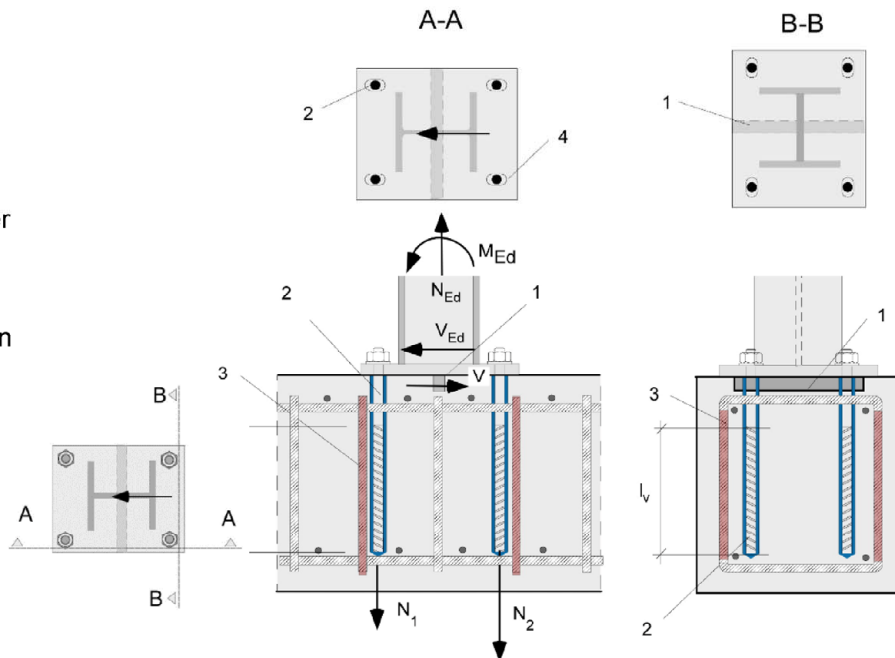
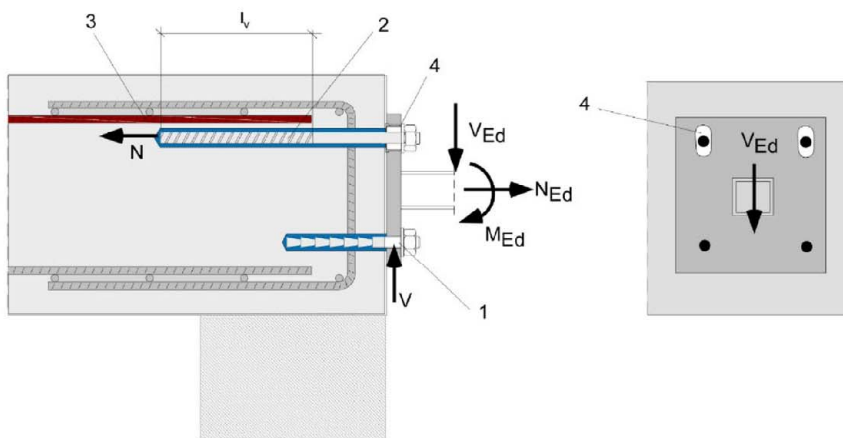

**Figure A3.2:**

Lap of the anchoring of guardrail posts or anchoring of cantilevered building components.

In the anchor plate, the drill holes for the fischer rebar anchors FRA have to be designed as slotted holes with axial direction to the shear force.

1. Fastener for shear load transfer
2. fischer rebar anchor FRA (tension only)
3. Existing stirrup / reinforcement for overlap (lap splice)
4. Slotted hole



The required transverse reinforcement acc. to EN 1992-1-1:2011 is not shown in the figures. **The fischer rebar anchor FRA may be only used for axial tensile force.** The tensile force must be transferred by lap to the existing reinforcement of the building. The transfer of the shear force has to be ensured by suitable measure, e.g. by means of shear force or anchors with European Technical Assessment (ETA).

Figures not to scale

Rebar connection with injection system FIS V Plus

**Product description**

Installation conditions and application examples fischer rebar anchors FRA

**Annex A 3**

Appendix 4 / 21

## Overview system components

**Injection cartridge (shuttle cartridge) FIS V Plus with sealing cap; Sizes: 360 ml, 825 ml**

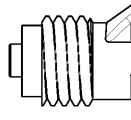
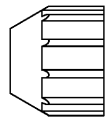

**Imprint:** fischer FIS V Plus or FIS VS Plus Low Speed, processing notes, shelf-life, hazard code, curing times and processing times (depending on temperature), piston travel scale (optional), size, volume



**Injection cartridge (coaxial cartridge) FIS V Plus with sealing cap; Sizes: 300 ml, 380 ml, 400 ml, 410 ml**

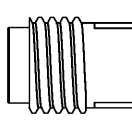
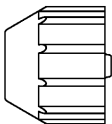

**Imprint:** fischer FIS FIS V Plus or FIS VS Plus Low Speed, processing notes, shelf-life, hazard code, curing times and processing times (depending on temperature), piston travel scale (optional), size, volume



**Static mixer FIS MR Plus for injection cartridges up to 410 ml**

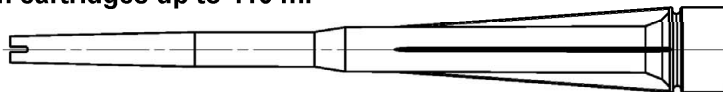

**Static mixer FIS JMR for injection cartridges 825 ml**

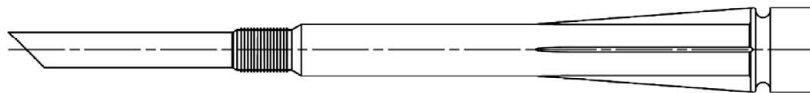

**Injection adapter and extension tube Ø 9 for static mixer FIS MR Plus;  
Injection adapter and extension tube Ø 9 or Ø 15 for static mixer FIS JMR**

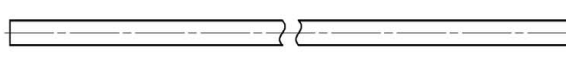
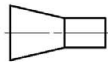

**Reinforcing bar (rebar) Sizes:  $\phi 8$ ,  $\phi 10$ ,  $\phi 12$ ,  $\phi 14$ ,  $\phi 16$ ,  $\phi 20$ ,  $\phi 25$ ,  $\phi 28$**



marking setting depth

**fischer rebar anchor FRA / FRA HCR Sizes: M12, M16, M20, M24**

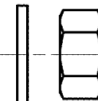

**Blow out pump AB G**



**Compressed-air cleaning tool ABP with fischer compressed-air nozzle**

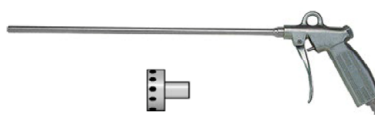

Figures not to scale

**Rebar connection with injection system FIS V Plus**

### Product description

Overview system components; Injection mortar, static mixer, injection adapter, reinforcing bar, fischer rebar anchor FRA, cleaning tools

**Annex A 4**

Appendix 5 / 21

## Properties of reinforcing bars (rebar)

Figure A5.1:



- The minimum value of related rib area  $f_{R,min}$  according to EN 1992-1-1:2011
- The maximum outer rebar diameter over the ribs shall be:
  - The nominal diameter of the bar with rib  $\phi + 2 \cdot h$  ( $h \leq 0,07 \cdot \phi$ )
  - ( $\phi$ : Nominal diameter of the bar;  $h_{rib}$  = rib height of the bar)

Table A5.1: Installation conditions for rebars

Nominal diameter of the bar		$\phi$	8 <sup>1)</sup>		10 <sup>1)</sup>		12 <sup>1)</sup>		14	16	20	25 <sup>1)</sup>		28
Nominal drill hole diameter	$d_0$	[mm]	10	12	12	14	14	16	18	20	25	30	35	35
Drill hole depth	$h_0$		$h_0 = l_v$											
Effective embedment depth	$l_v$		acc. to static calculation											
Minimum thickness of concrete member	$h_{min}$		$l_v + 30$ ( $\geq 100$ )						$l_v + 2d_0$					

<sup>1)</sup> Both drill hole diameters can be used

Table A5.2: Materials of rebars

Designation	Reinforcing bar (rebar)
Reinforcing bar EN 1992-1-1:2011, Annex C	Bars and de-coiled rods class B or C with $f_{yk}$ and $k$ according to NDP or NCI of EN 1992-1-1/NA $f_{uk} = f_{tk} = k \cdot f_{yk}$

Figures not to scale

Rebar connection with injection system FIS V Plus

**Product description**  
Properties and materials of reinforcing bars (rebar)

**Annex A 5**

Appendix 6 / 21



## Properties of fischer rebar anchors FRA

Figure A6.1:

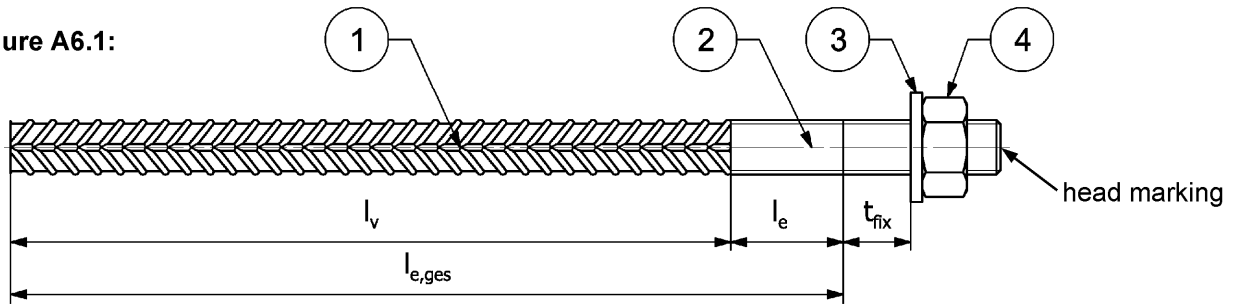

Head marking e.g.:  FRA (for stainless steel)

 FRA HCR (for high corrosion-resistant steel)

Table A6.1: Installation conditions for fischer rebar anchors FRA

Thread diameter		M12 <sup>2)</sup>	M16	M20	M24 <sup>2)</sup>
Nominal diameter	$\phi$ [mm]	12	16	20	25
Nominal drill bit diameter	$d_0$ [mm]	14   16	20	25	30   35
Drill hole depth ( $h_0 = l_{e,ges}$ )	$l_{e,ges}$ [mm]	$l_v + l_e$			
Effective embedment depth	$l_v$ [mm]	according to static calculation			
Distance concrete surface to welded joint	$l_e$ [mm]	100			
Maximum Diameter of clearance hole in the fixture <sup>1)</sup>	Pre-positioned $d_f$ [mm]	14	18	22	26
	Push through $d_f$ [mm]	16   18	22	26	32   ---
Minimum thickness of concrete member	$h_{min}$ [mm]	$h_0+30$	$h_0 + 2d_0$		
Maximum torque moment for attachment of the fixture	$\max T_{inst}$ [Nm]	50	100	150	150

<sup>1)</sup> For bigger clearance holes in the fixture see EN 1992-4:2018

<sup>2)</sup> Both drill bit diameters can be used

Table A6.2: Materials of fischer rebar anchors FRA

Part	Description	Materials	
		FRA Corrosion resistance class CRC III acc. to EN 1993-1-4:2006+A1:2015	FRA HCR Corrosion resistance class CRC V acc. to EN 1993-1-4: 2006+A1:2015
1	Reinforcing bar	Bars and de-coiled rods class B or C with $f_{yk}$ and $k$ according to NDP or NCI of EN 1992-1-1:NA; $f_{uk} = f_{tk} = k \cdot f_{yk}$ ; ( $f_{yk} = 500 \text{ N/mm}^2$ )	
2	Round bar with partial or full thread	Stainless steel, strength class 80, according to EN 10088-1:2014	Stainless steel, strength class 80, according to EN 10088-1:2014
3	Washer ISO 7089:2000	Stainless steel, according to EN 10088-1:2014	Stainless steel, according to EN 10088-1:2014
4	Hexagon nut	Stainless steel, strength class 80, acc. to EN ISO 3506-2:2020, according to EN 10088-1:2014	Stainless steel, strength class 80, acc. to EN ISO 3506-2:2020, according to EN 10088-1:2014

Figures not to scale

Rebar connection with injection system FIS V Plus

### Product description





Properties and materials of fischer rebar anchors FRA

### Annex A 6

Appendix 7 / 21

# Specifications of intended use part 1

**Table B1.1:** Overview use and performance categories

Anchorages subject to		FIS V Plus with ...			
		Reinforcing bar 		fischer rebar anchor FRA 	
Hammer drilling or compressed air drilling with standard drill bit 		all sizes			
Hammer drilling with hollow drill bit (fischer "FHD", Heller "Duster Expert", Bosch "Speed Clean", Hilti "TE-CD, TE-YD") 		Nominal drill bit diameter ( $d_0$ ) 12 mm to 35 mm			
Use category I1	dry or wet concrete	all sizes			
Characteristic resistance under static and quasi static loading, in	uncracked concrete	all sizes	Tables: C1.1 C1.2 C1.3	all sizes	Tables: C1.1 C1.2 C1.3 C2.1 C2.2
	cracked concrete				
Characteristic resistance under seismic loading		--- <sup>1)</sup>		--- <sup>1)</sup>	
Installation direction		D3 (downward and horizontal and upwards (e.g. overhead))			
Installation temperature		$T_{i,min} = 0\text{ °C}$ to $T_{i,max} = +40\text{ °C}$			
Service temperature	Temperature range	-40 °C to +80 °C		(max. short term temperature +80 °C; max long term temperature +50 °C)	
Resistance to fire		all sizes	Annex C 3	all sizes	Table C2.3

<sup>1)</sup> No performance assessed

Rebar connection with injection system FIS V Plus

**Intended use**  
Specifications part 1

**Annex B 1**

Appendix 8 / 21

## Specifications of intended use part 2

### Anchorage subject to:

- Static and quasi-static loading: reinforcing bar (rebar) size 8 mm to 28 mm; FRA M12 to M24
- Resistance to fire: reinforcing bar (rebar) size 8 mm to 28 mm; FRA M12 to M24

### Base materials:

- Compacted reinforced or unreinforced normal weight concrete without fibres according to EN 206:2013+A1:2016
- Concrete strength classes C12/15 to C50/60 according to EN 206:2013+A1:2016
- Maximum chloride content of 0,40 % (CL 0.40) related to the cement content according to EN 206:2013+A1:2016
- Non-carbonated concrete

Note: In case of a carbonated surface of the existing concrete structure the carbonated layer shall be removed in the area of the post-installed rebar connection with a diameter of  $\phi + 60$  mm prior to the installation of the new rebar. The depth of concrete to be removed shall correspond to at least the minimum concrete cover in accordance with EN 1992-1-1 :2004+AC:2010. The foregoing may be neglected if building components are new and not carbonated and if building components are in dry conditions.

### Use conditions (Environmental conditions) for fischer rebar anchors FRA

- For all conditions according to EN1993-1-4:2006+A1:2015 corresponding to corrosion resistance classes to **Annex A 6 Table A6.2**.

### Design:

- Fastenings are designed under the responsibility of an engineer experienced in fastenings and concrete work.
- Verifiable calculation notes and drawings are prepared taking account of the forces to be transmitted.
- Design according to EN 1992-1-1:2011; EN 1992-1-2:2011 and **Annex B 3 and B 4**.
- The actual position of the reinforcement in the existing structure shall be determined on the basis of the construction documentation and taken into account when designing.

### Installation:

- The installation of post-installed rebar respectively fischer rebar anchor FRA shall be done only by suitable trained installer and under Supervision on site; the conditions under which an installer may be considered as suitable trained and the conditions for Supervision on site are up to the Member States in which the installation is done.
- Check the position of the existing rebars (if the position of existing rebars is not known, it shall be determined using a rebar detector suitable for this purpose as well as on the basis of the construction documentation and then marked on the building component for the overlap joint).

Rebar connection with injection system FIS V Plus

**Intended use**  
Specifications part 2

**Annex B 2**

Appendix 9 / 21

## General construction rules for post-installed rebars

**Figure B3.1:**

- Only tension forces in the axis of the rebar may be transmitted.
- The transfer of shear forces between new concrete and existing structure shall be designed additionally according to EN 1992-1-1:2011.
- The joints for concreting must be roughened to at least such an extent that aggregate protrude.

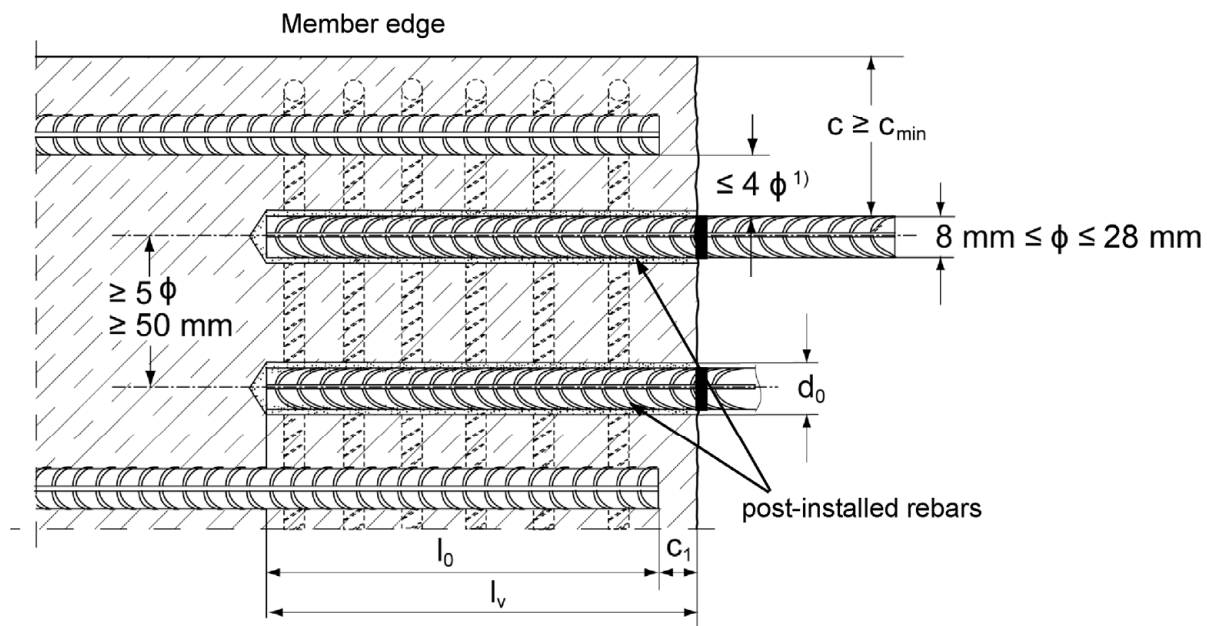

1) If the clear distance between lapped bars exceeds  $4 \phi$  then the lap length shall be increased by the difference between the clear bar distance and  $4 \phi$

- $c$  concrete cover of post-installed rebar  
 $c_1$  concrete cover at end-face of existing rebar  
 $c_{min}$  minimum concrete cover according to **Table B5.1** and to EN 1992-1-1:2011, Section 4.4.1.2  
 $\phi$  nominal diameter of reinforcing bar  
 $l_0$  lap length, according to EN 1992-1-1:2011  
 $l_v$  effective embedment depth,  $\geq l_0 + c_1$   
 $d_0$  nominal drill bit diameter, see **Annex B 6**

Figures not to scale

Rebar connection with injection system FIS V Plus

**Intended use**  
 General construction rules for post-installed rebars

**Annex B 3**

Appendix 10 / 21

# General construction rules for post-installed fischer rebar anchors FRA

**Figure B4.1:**

- Only tension forces in the axis of the fischer rebar anchor FRA may be transmitted.
- The tension force must be transferred via an overlap joint to the reinforcement in the building part.
- The transmission of the shear load shall be ensured by appropriate additional measures, e.g. by shear lugs or by anchors with a European Technical Assessment (ETA).
- In the anchor plate, the holes for the tension anchor shall be executed as slotted holes with the axis in the direction of the shear force.

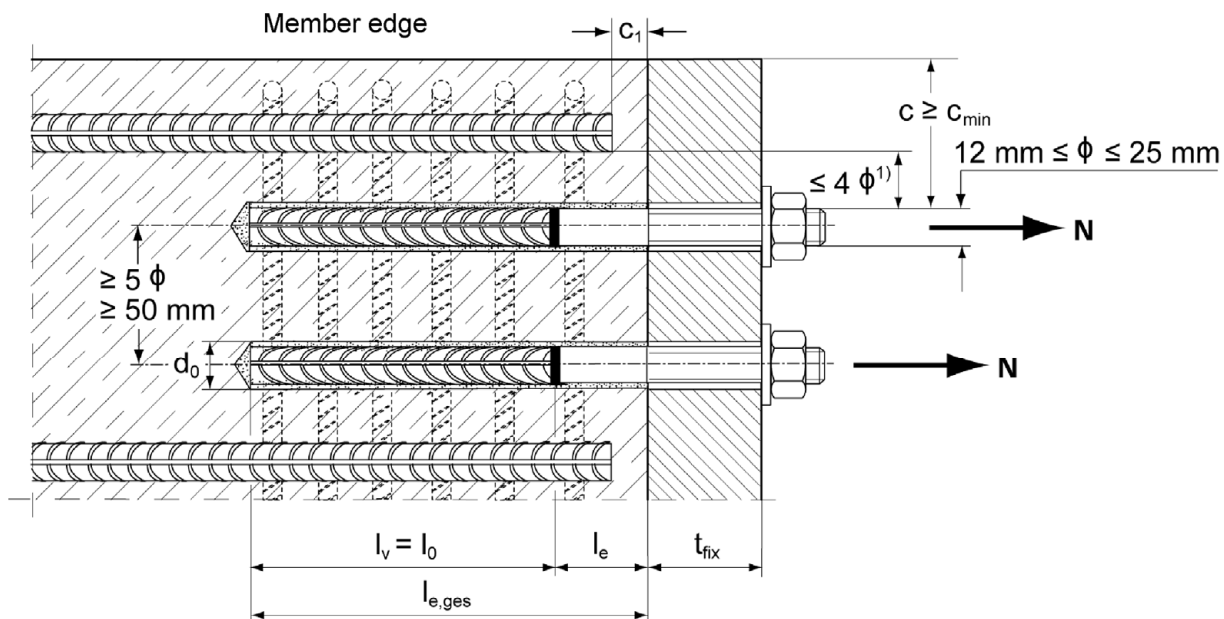

1) If the clear distance between lapped bars exceeds  $4\phi$  then the lap length shall be increased by the difference between the clear bar distance and  $4\phi$ .

- c concrete cover of post-installed fischer rebar anchor FRA
- $c_1$  concrete cover at end-face of existing rebar
- $c_{min}$  minimum concrete cover according to **Table B5.1** and to EN 1992-1-1:2011, Section 4.4.1.2
- $\phi$  nominal diameter of reinforcing bar
- $l_0$  lap length, according to EN 1992-1-1:2011, Section 8.7.3
- $l_{e, ges}$  overall embedment depth,  $\geq l_0 + l_e$
- $d_0$  nominal drill bit diameter, see **Annex B 6**
- $l_e$  length of the bonded in threaded part
- $t_{fix}$  thickness of the fixture
- $l_v$  effective embedment depth

Figures not to scale

Rebar connection with injection system FIS V Plus

**Intended use**

General construction rules for post-installed fischer rebar anchors FRA

**Annex B 4**

Appendix 11 / 21

**Table B5.1: Minimum concrete cover  $c_{min}^{1)}$  depending of the drilling method and the drilling tolerance**

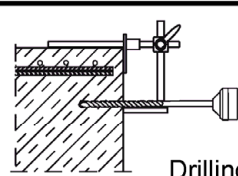
Drilling method	nominal diameter of reinforcing bar $\phi$ [mm]	Minimum concrete cover $c_{min}$		
		Without drilling aid [mm]	With drilling aid [mm]	
Hammer drilling with standard drill bit or hollow drill bit	< 25	$30 \text{ mm} + 0,06 l_v \geq 2 \phi$	$30 \text{ mm} + 0,02 l_v \geq 2 \phi$	
	$\geq 25$	$40 \text{ mm} + 0,06 l_v \geq 2 \phi$	$40 \text{ mm} + 0,02 l_v \geq 2 \phi$	
Compressed air drilling	< 25	$50 \text{ mm} + 0,08 l_v$	$50 \text{ mm} + 0,02 l_v$	
	$\geq 25$	$60 \text{ mm} + 0,08 l_v \geq 2 \phi$	$60 \text{ mm} + 0,02 l_v \geq 2 \phi$	

<sup>1)</sup> See Annex B 3, figure B3.1 and Annex B 4, figure B4.1

Note: The minimum concrete cover as specified in EN 1992-1-1:2011 must be observed.

**Table B5.2: Dispensers and cartridge sizes corresponding to maximum embedment depth  $l_{v,max}$**

reinforcing bars (rebar)	fischer rebar anchor FRA	Manual dispenser	Accu and pneumatic dispenser (small)	Accu and pneumatic dispenser (large)
		Cartridge size		
$\phi$ [mm]	thread [-]	< 500 ml	> 500 ml	
		$l_{v,max} / l_{e,ges,max}$ [mm]		$l_{v,max} / l_{e,ges,max}$ [mm]
8	---	1000	1000	1800
10	---		1200	
12	FRA M12 FRA HCR M12		1500	
14	---		1300	
16	FRA M16 FRA HCR M16	700	1000	2000
20	FRA M20 FRA HCR M20		700	
25	FRA M24 FRA HCR M24		700	
28	---	700	700	

**Table B5.3: Conditions for use static mixer without an extension tube**

Nominal drill hole diameter $d_0$	[mm]	10	12	14	16	18	20	25	30	35
		Drill hole depth $h_0$ by using	FIS MR Plus	$\leq 90$	$\leq 120$	$\leq 140$	$\leq 150$	$\leq 160$	$\leq 210$	
	FIS JMR	-	-	$\leq 90$	$\leq 160$	$\leq 180$	$\leq 190$	$\leq 220$	$\leq 250$	

Rebar connection with injection system FIS V Plus

**Intended use**

Minimum concrete cover;  
dispenser and cartridge sizes corresponding to maximum embedment depth

**Annex B 5**

Appendix 12 / 21

**Table B6.1: Working times  $t_{work}$  and curing times  $t_{cure}$** 

Temperature in the anchorage base [°C]	Maximum working time <sup>1)</sup> $t_{work}$		Minimum curing time <sup>2)</sup> $t_{cure}$	
	FIS V Plus	FIS VS Plus Low Speed	FIS V Plus	FIS VS Plus Low Speed
0 to 5 <sup>3)</sup>	13 min	---	3 h	6 h
> 5 to 10 <sup>3)</sup>	9 min	20 min	90 min	3 h
> 10 to 20	5 min	10 min	60 min	2 h
> 20 to 30	4 min	6 min	45 min	60 min
> 30 to 40 <sup>4)</sup>	2 min	4 min	35 min	60 min

1) Maximum time from the beginning of the injection to rebar / fischer rebar anchor FRA setting and positioning.

2) For wet concrete the curing time must be doubled.

3) If the temperature in the concrete falls below 10 °C the cartridge must be warmed up to +15 °C.

4) If the temperature in the concrete exceeds 30 °C the cartridge must be cooled down to +15 °C up to 20 °C.

**Table B6.2: Installation tools for drilling and cleaning the bore hole and injection of the mortar**

reinforcing bars (rebar) $\phi$ [mm]	fischer rebar anchor FRA Designation	Drilling and cleaning				Injection	
		Nominal drill bit diameter $d_0$ [mm]	Diameter of cutting edge $d_{cut}$ [mm]	Steel brush diameter $d_b$ [mm]	Diameter of fischer compressed-air nozzle [mm]	Diameter of extension tube [mm]	Injection adapter [colour]
8 <sup>1)</sup>	---	10	$\leq 10,50$	11,0	---	9	---
		12	$\leq 12,50$	12,5	11		nature
10 <sup>1)</sup>	---	12	$\leq 12,50$	12,5		15	9
		14	$\leq 14,50$	15	15		
12 <sup>1)</sup>	FRA M12 <sup>1)</sup> FRA HCR M12 <sup>1)</sup>	14	$\leq 14,50$	15		19	9 or 15
		16	$\leq 16,50$	17	19		
14	---	18	$\leq 18,50$	19		28	9 or 15
16	FRA M16 FRA HCR M16	20	$\leq 20,55$	21,5	28		
20	FRA M20 FRA HCR M20	25	$\leq 25,55$	26,5		28	brown
25 <sup>1)</sup>	FRA M24 <sup>1)</sup> FRA HCR M24 <sup>1)</sup>	30	$\leq 30,55$	32	28		brown
		35	$\leq 35,70$	37		28	brown
28	---	35	$\leq 35,70$	37			brown

1) Both drill bit diameters can be used.

Rebar connection with injection system FIS V Plus

**Intended use**

Working times and curing times;  
Installation tools for drilling and cleaning the bore hole and injection of the mortar

**Annex B 6**

Appendix 13 / 21

## Safety regulations



Review the Safety Data Sheet (SDS) before use for proper and safe handling!  
Wear well-fitting protective goggles and protective gloves when working with mortar FIS V Plus / FIS VS Plus Low Speed.  
Important: Observe the instructions for use provided with each cartridge.

## Installation instruction part 1; Installation with FIS V Plus / FIS VS Plus Low Speed

### Hole drilling

Note: Before drilling, remove carbonized concrete; clean contact areas (see **Annex B 2**)  
In case of aborted drill holes the drill hole shall be filled with mortar.

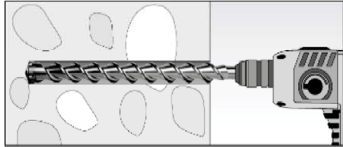
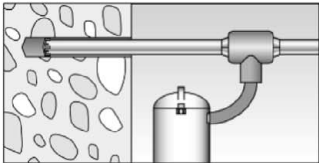
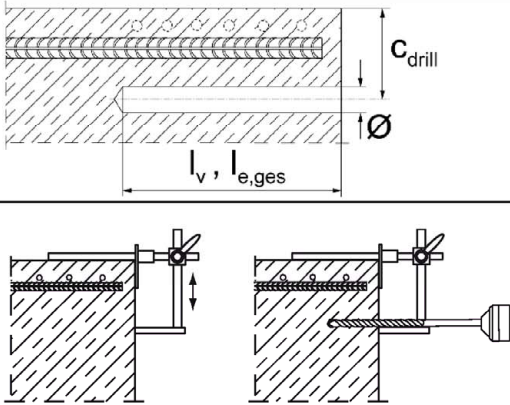
1a	<p><b>Hammer drilling or compressed air drilling</b></p> 	<p>Drill the hole to the required embedment depth using a hammer drill with carbide drill bit set in rotation hammer mode or a pneumatic drill. Drill bit sizes see <b>Table B6.2</b>.</p>
1b	<p><b>Hammer drilling with hollow drill bit</b></p> 	<p>Drill the hole to the required embedment depth using a hammer drill with hollow drill bit in rotation hammer mode. Dust extraction conditions see drill hole cleaning <b>Annex B 8</b>. Drill bit sizes see <b>Table B6.2</b>.</p>
2		<p>Measure and control concrete cover <math>c</math> (<math>c_{\text{drill}} = c + \text{Ø} / 2</math>) Drill parallel to surface edge and to existing rebar. Where applicable use drilling aid.</p> <p>For holes <math>l_v &gt; 20</math> cm use drilling aid. Three different options can be considered: A) drilling aid B) Slat or spirit level C) Visual check</p> <p>Minimum concrete cover <math>c_{\text{min}}</math> see <b>Table B5.1</b>.</p>

Rebar connection with injection system FIS V Plus

**Intended use**  
Safety regulations; Installation instruction part 1, hole drilling

**Annex B 7**

Appendix 14 / 21



# Installation instruction part 2; Installation with FIS V Plus / FIS VS Plus Low Speed

## Drill hole cleaning

### Hammer or compressed air drilling

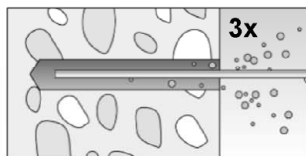

Clean the drill hole:  
For  $d_0 < 18$  mm and depths  $l_v$  resp.  
 $l_{e,ges} \leq 12 \cdot \phi$   
blow out the hole three times by hand.

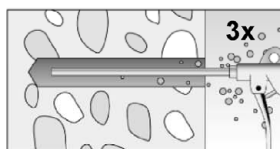

For  $d_0 > 18$  mm and depths  $l_v$  resp.  
 $l_{e,ges} > 12 \cdot \phi$  blow out the hole three times with oil-free compressed air ( $p \geq 6$  bar). Use suitable compressed-air nozzle (see **Table B6.2**).

3a

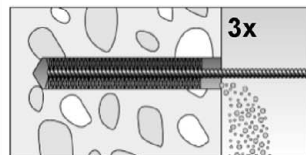

Brush drill hole three times; for drill hole diameters  $d_0 \geq 30$  mm attach brush to a power tool and brush hole with a speed of max. 550 revolutions per minute. For deep holes a brush extension is mandatory. Use suitable brushes (see **Table B6.2**).

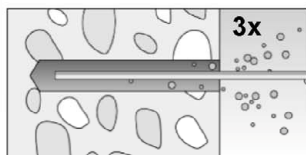

Clean the drill hole:  
For  $d_0 < 18$  mm and depths  $l_v$  resp.  
 $l_{e,ges} \leq 12 \cdot \phi$   
blow out the hole three times by hand.

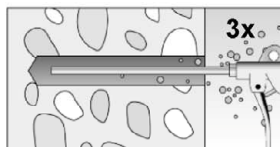

For  $d_0 > 18$  mm and depths  $l_v$  resp.  
 $l_{e,ges} > 12 \cdot \phi$  blow out the hole three times with oil-free compressed air ( $p \geq 6$  bar) Use suitable compressed-air nozzle (see **Table B6.2**).

### Hammer drilling with hollow drill bit



3b

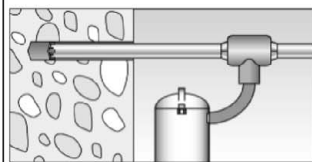

Use a suitable dust extraction system, e. g. fischer FVC 35 M or a comparable dust extraction system with equivalent performance data. Drill the hole with hollow drill bit. The dust extraction system has to extract the drill dust nonstop during the drilling process and must be adjusted to maximum power. No further drill hole cleaning necessary.

Rebar connection with injection system FIS V Plus

**Intended use**  
Installation instruction part 2, drill hole cleaning

**Annex B 8**

Appendix 15 / 21

**Installation instruction part 3; Installation with FIS V Plus / FIS VS Plus Low Speed**  
**reinforcing bars (rebar) / fischer rebar anchor FRA and cartridge preparation**

4		<p>Before use, make asure that the rebar or the fischer rebar anchor FRA is dry and free of oil or other residue.          Mark the embedment depth <math>l_v</math> (e.g. with tape)          Insert rebar in borehole, to verify drill hole depth and setting depth <math>l_v</math> resp. <math>l_{e,ges}</math>.</p>
5		<p>Twist off the sealing cap          Twist on the static mixer (the spiral in the static mixer must be clearly visible).</p>
6		<p>Place the cartridge into a suitable dispenser.</p>
7		<p>Press out approximately 10 cm of mortar until the resin is permanently grey in colour. Mortar which is not grey in colour will not cure and must be disposed.</p>

Rebar connection with injection system FIS V Plus

**Intended use**  
 Installation instruction part 3,  
 reinforcing bars (rebar) / fischer rebar anchor FRA and cartridge preparation

**Annex B 9**

Appendix 16 / 21

## Installation instruction part 4; Installation with FIS V Plus / FIS VS Plus Low Speed

### Injection of the mortar without extension tube

8a

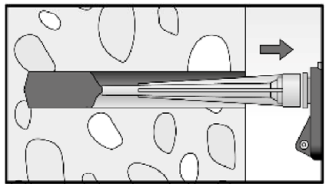

Inject the mortar from the back of the hole towards the front and slowly withdraw the static mixer step by step with each trigger pull. Avoid bubbles. Fill holes approximately 2/3 full, to ensure that the annular gap between the rebar and the concrete will be completely filled with adhesive over the entire embedment length. The conditions for mortar injection without extension tube can be found in **Table B5.3**.

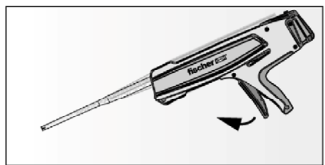

After injecting, release the dispenser. This will prevent further mortar discharge from the static mixer.

### Injection of the mortar with extension tube

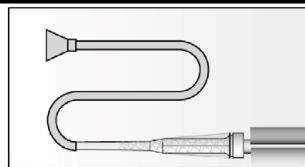

Assemble mixing nozzle FIS MR Plus or FIS JMR, extension tube and appropriate injection adapter (see **Table B6.2**).

Mortar level mark

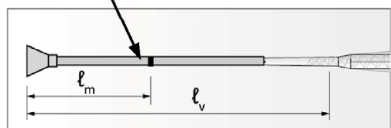

Mark the required mortar level  $l_m$  and embedment depth  $l_v$  resp.  $l_{e,ges}$  with tape or marker on the injection extension tube.

a) Estimation:

$$l_m = \frac{1}{3} \cdot l_v \text{ resp. } l_m = \frac{1}{3} \cdot l_{e,ges} \text{ [mm]}$$

b) Precise equation for optimum mortar volume:

$$l_m = l_v \text{ resp. } l_{e,ges} \left( (1,2 \cdot \frac{d_s^2}{d_0^2} - 0,2) \right) \text{ [mm]}$$

8b

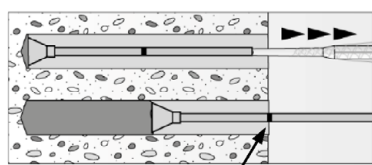

Mortar level mark

Insert injection adapter to back of the hole. Begin injection allowing the pressure of the injected adhesive mortar to push the injection adapter towards the front of the hole. Do not actively pull out! Fill holes approximately 2/3 full, to ensure that the annular gap between the rebar and the concrete will be completely filled with adhesive over the embedment length. When using an injection adapter continue injection until the mortar level mark  $l_m$  becomes visible. Maximum embedment depth see **Table B5.2**.

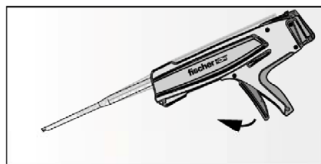

After injecting, release the dispenser. This will prevent further mortar discharge from static mixer.

Rebar connection with injection system FIS V Plus

**Intended use**



Installation instruction part 4, mortar injection

**Annex B 10**

Appendix 17 / 21

# Installation instruction part 5; Installation with FIS V Plus / FIS VS Plus Low Speed

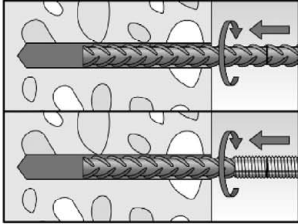
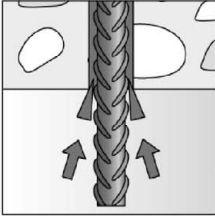
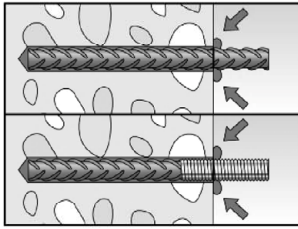
## Insert rebar / fischer rebar anchor FRA

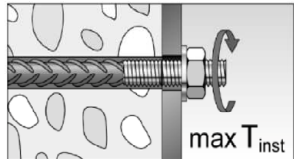
9		<p>Insert the rebar / fischer rebar anchor FRA slowly twisted into the borehole until the embedment mark is reached.                  Recommendation:                  Rotation back and forth of the reinforcement bar or the fischer rebar anchor FRA makes pushing easy.</p>
10		<p>For overhead installation, support the rebar / fischer rebar anchor FRA and secure it from falling till mortar started to harden, e.g. using wedges.</p>
11		<p>After installing the rebar or fischer rebar anchor FRA the annular gap must be completely filled with mortar.</p> <p>Proper installation</p> <ul style="list-style-type: none"> <li>• Desired embedment depth is reached <math>l_v</math>, resp. <math>l_{e,ges}</math>: embedment mark at concrete surface</li> <li>• Excess mortar flows out of the borehole after the rebar has been fully inserted up to the embedment mark.</li> </ul>
12		<p>Observe the working time "<math>t_{work}</math>" (<b>see Table B6.1</b>), which varies according to temperature of base material. Minor adjustments to the rebar / fischer rebar anchor FRA position may be performed during the working time</p> <p>Full load may be applied only after the curing time "<math>t_{cure}</math>" has elapsed (<b>see Table B 6.1</b>).</p>
13		<p>Mounting the fixture for fischer rebar anchor FRA, max <math>T_{inst}</math> see <b>Table A6.1</b>.</p>

Rebar connection with injection system FIS V Plus

**Intended use**

Installation instruction part 5, insert rebar / fischer rebar anchor FRA

**Annex B 11**

Appendix 18 / 21

## Minimum anchorage length and minimum lap length

The minimum anchorage length  $l_{b,min}$  and the minimum lap length  $l_{o,min}$  according to EN 1992-1-1:2011 shall be multiplied by the relevant amplification factor  $\alpha_{lb}$  according to **Table C1.1**.

**Table C1.1:** Amplification factor  $\alpha_{lb}$  related to concrete strength class and drilling method

### Hammer drilling, hollow drilling and compressed air drilling

Rebar / fischer rebar anchor FRA	Amplification factor $\alpha_{lb}$								
	Concrete strength class								
	$\phi$ [mm]	C12/15	C16/20	C20/25	C25/30	C30/37	C35/45	C40/50	C45/55
8 to 25	1,0						1,1		1,2
28	1,0								

**Table C1.2:** Bond efficiency factor  $k_b$  related to concrete strength class and drilling method

### Hammer drilling, hollow drilling and compressed air drilling

Rebar / fischer rebar anchor FRA	Bond efficiency factor $k_b$									
	Concrete strength class									
	$\phi$ [mm]	C12/15	C16/20	C20/25	C25/30	C30/37	C35/45	C40/50	C45/55	C50/60
8 to 25	1,00									
28	1,00						0,91	0,84	0,84	

**Table C1.3:** Design values of the bond strength  $f_{bd,PIR}$  in N/mm<sup>2</sup> related to concrete strength class and drilling method for good bond conditions

$$f_{bd,PIR} = k_b \cdot f_{bd}$$

$f_{bd}$ : Design value of the bond strength in N/mm<sup>2</sup> considering the concrete strength classes and the rebar diameter for good bond condition (for all other bond conditions multiply the values by  $\eta_1 = 0,7$ ) and recommended partial factor  $\gamma_c = 1,5$  according to EN 1992-1-1:2011

$k_b$ : Bond efficiency factor according to **Table C1.2**

### Hammer drilling, hollow drilling and compressed air drilling

Rebar / fischer rebar anchor FRA	Bond strength $f_{bd,PIR}$ [N/mm <sup>2</sup> ]								
	Concrete strength class								
	$\phi$ [mm]	C12/15	C16/20	C20/25	C25/30	C30/37	C35/45	C40/50	C45/55
8 to 25	1,6	2,0	2,3	2,7	3,0	3,4	3,7	4,0	4,3
28	1,6	2,0	2,3	2,7	3,0	3,4	3,4	3,4	3,7

Rebar connection with injection system FIS V Plus

#### Performance

Amplification factor  $\alpha_{lb}$ , bond efficiency factor  $k_b$ , design values of the bond strength  $f_{bd,PIR}$

**Annex C 1**

Appendix 19 / 21

**Table C2.1: Characteristic tensile yield strength for rebar part of fischer rebar anchors FRA**

fischer rebar anchor FRA / FRA HCR			M12	M16	M20	M24
<b>Characteristic tensile yield strength for rebar part</b>						
Rebar diameter	$\phi$	[mm]	12	16	20	25
Characteristic tensile yield strength for rebar	$f_{yk}$	[N/mm <sup>2</sup> ]	500	500	500	500
Partial factor for rebar part	$\gamma_{Ms,N}^{1)}$	[-]	1,15			

<sup>1)</sup> In absence of national regulations

**Table C2.2: Characteristic resistance to steel failure under tension loading of fischer rebar anchors FRA**

fischer rebar anchor FRA / FRA HCR			M12	M16	M20	M24
<b>Characteristic resistance to steel failure under tension loading</b>						
Characteristic resistance	$N_{RK,s}$	[kN]	62	111	173	263
<b>Partial factor</b>						
Partial factor	$\gamma_{Ms,N}^{1)}$	[-]	1,4			

<sup>1)</sup> In absence of national regulations

**Table C2.3: Characteristics resistance to steel failure for fischer rebar anchors FRA under tension loading and fire exposure R30 to R120**

fischer rebar anchor FRA / FRA HCR				M12	M16	M20	M24
Characteristic resistance to steel failure under tension loading and fire exposure	R30	$N_{RK,s,fi}$	[kN]	2,5	4,7	7,4	10,6
	R60			2,1	3,9	6,1	8,8
	R90			1,7	3,1	4,9	7,1
	R120			1,3	2,5	3,9	5,6

ANNEX C 2

Rebar connection with injection system FIS V Plus  <b>Performance</b> Characteristic tensile yield strength for rebar part of FRA; Design value of the steel bearing capacity $N_{RK,s,fi}$ under fire exposure for fischer rebar anchor FRA	<b>Annex C 2</b> Appendix 20 / 21
---	--------------------------------------

## Design value of the ultimate bond strength $f_{bd,fi}$ at increased temperature for concrete strength classes C12/15 to C50/60 (all drilling methods)

The design value of the bond strength  $f_{bd,fi}$  at increased temperature has to be calculated by the following equation:

$$f_{bd,fi} = k_{fi}(\theta) \cdot f_{bd,PIR} \cdot \frac{\gamma_c}{\gamma_{m,fi}}$$

$$\text{If: } \theta > 74 \text{ } ^\circ\text{C} \quad k_{fi}(\theta) = \frac{24,308 \cdot e^{-0,012 \cdot \theta}}{f_{bd,PIR} \cdot 4,3} \leq 1,0$$

$$\text{If: } \theta > \theta_{\max} (317 \text{ } ^\circ\text{C}) \quad k_{fi}(\theta) = 0$$

$f_{bd,fi}$  = Design value of the ultimate bond strength at increased temperature in N/mm<sup>2</sup>

$\theta$  = Temperature in °C in the mortar layer

$k_{fi}(\theta)$  = Reduction factor at increased temperature

$f_{bd,PIR}$  = Design value of the bond strength in N/mm<sup>2</sup> in cold condition according to **Table C1.3** considering the concrete strength classes, the rebar diameter, the drilling method and the bond conditions according to EN 1992-1-1:2011

$\gamma_c$  = 1,5 recommended partial factor according to EN 1992-1-1:2011

$\gamma_{m,fi}$  = 1,0 recommended partial factor

For evidence at increased temperature the anchorage length shall be calculated according to EN 1992-1-1:2011 Equation 8.3 using the temperature-dependent ultimate design value of bond strength  $f_{bd,fi}$ .

**Figure C3.1:** Example graph of reduction factor  $k_{fi}(\theta)$  for concrete class C20/25 for good bond conditions

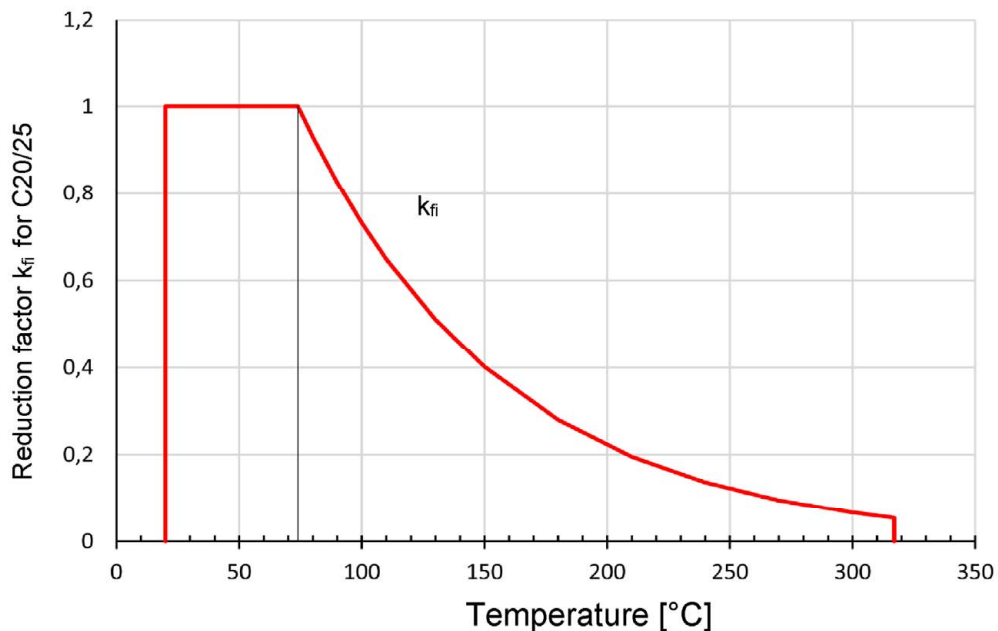

Rebar connection with injection system FIS V Plus

### Performance

Design value of bond strength  $f_{bd,fi}$  at increased temperature

**Annex C 3**

Appendix 21 / 21