

DECLARAÇÃO DE DESEMPENHO

DoP 0365

para sistema de injeção fischer FIS RC II (Argamassa para conexões de armaduras pós-instaladas)

PT

- Código de identificação único do produto-tipo:** DoP 0365
- Utilização(ões) prevista(s):** Sistema para conexão de armaduras pós-instaladas com argamassa para uso em betão, Ver anexos, especialmente anexos B1-B11.
- Fabricante:** fischerwerke GmbH & Co. KG, Klaus-Fischer-Str. 1, 72178 Waldachtal, Alemanha
- Representante autorizado:** -
- Sistema(s) de avaliação e verificação da regularidade do desempenho (AVCP):** 1
- Documento de Avaliação Europeu:** EAD 330087-01-0601 Edition 06/2021
Avaliação Técnica Europeia: ETA-22/0502; 2024-06-10
Organismo de Avaliação Técnica: DIBt- Deutsches Institut für Bautechnik
Organismo(s) notificado(s): 2873 TU Darmstadt
- Desempenho(s) declarado(s):**
Resistência mecânica e estabilidade (BWR 1)
Resistência característica sob ação estática e quase estática:
Tensão de aderência de armaduras pós-instaladas: Anexos C1, C2
Fator de redução: Anexos C1, C2
Fator de amplificação para comprimento mínimo de ancoragem: Anexos C1, C2
Resistência característica à rotura do aço sob tensão de tração do varão: Anexo C5

Resistência característica sob ação sísmica:
Tensão de aderência sob ação sísmica, fator de eficiência de aderência sísmico: Anexos C3, C4
Recobrimento mínimo sob ação sísmica: Anexo B5

Segurança em caso de incêndio (BWR 2)
Reação ao fogo: Classe (A1)

Resistência ao fogo:
Tensão de aderência para temperaturas para armaduras pós-instaladas avaliadas para 50 anos: Anexo C6
Tensão de aderência para temperaturas para armaduras pós-instaladas avaliadas para 100 anos: Anexo C6
Resistência característica à rotura do aço sob tensão de tração do varão sob exposição ao fogo: Anexo C5
- Documentação Técnica Adequada e/ou Documentação Técnica Específica:** -

O desempenho do produto identificado acima está em conformidade com o conjunto de desempenhos declarados. A presente declaração de desempenho é emitida, em conformidade com o Regulamento (UE) n.º 305/2011, sob a exclusiva responsabilidade do fabricante identificado acima.

Assinado por e em nome do fabricante por:



Dr.-Ing. Oliver Geibig, Diretor Administrativo de Unidades de Negócios e Engenharia
Tumlingen, 2024-06-24

Jürgen Grün, Diretor Administrativo de Química e Qualidade

Este DoP foi preparado em diferentes línguas. Em caso de litígio sobre a interpretação, a versão em inglês prevalecerá sempre.

O Anexo inclui informações voluntárias e complementares em inglês que excedem os requisitos legais (linguisticamente especificados).

Translation guidance Essential Characteristics and Performance Parameters for Annexes

Guia de tradução das Características Essenciais e Parâmetros de Desempenho para os Anexos

Mechanical resistance and stability (BWR 1)		
Resistência mecânica e estabilidade (BWR 1)		
Characteristic resistance under static and quasi-static loading: Resistência característica sob ação estática e quase estática:		
1	Bond strength of post-installed rebar: Tensão de aderência de armaduras pós-instaladas:	$f_{bd,PIR}$ [N/mm ²], $f_{bd,PIR,100y}$ [N/mm ²]
2	Bond efficiency factor: Fator de redução:	k_b [-], $k_{b,100y}$ [-]
3	Amplification factor for minimum anchorage length: Fator de amplificação para comprimento mínimo de ancoragem:	α_b [-], $\alpha_{b,100y}$ [-]
4	Characteristic resistance to steel failure for rebar tension anchors: Resistência característica à rotura do aço sob tensão de tração do varão:	$N_{Rk,s}$ [kN]
Characteristic resistance under seismic loading: Resistência característica sob ação sísmica:		
5	Bond strength under seismic loading, Seismic bond efficiency factor: Tensão de aderência sob ação sísmica, fator de eficiência de aderência sísmico:	$f_{bd,PIR,seis}$ [N/mm ²], $k_{b,seis}$ [-], $f_{bd,PIR,seis,100y}$ [N/mm ²], $k_{b,seis,100y}$ [-]
6	Minimum concrete cover under seismic loading: Recobrimento mínimo sob ação sísmica:	$c_{min,seis}$ [mm]
Safety in case of fire (BWR 2)		
Segurança em caso de incêndio (BWR 2)		
7	Reaction to fire: Reação ao fogo:	Class
Resistance to fire: Resistência ao fogo:		
8	Bond strength at increased temperature for post-installed rebar assessed for 50 years: Tensão de aderência para temperaturas para armaduras pós-instaladas avaliadas para 50 anos:	$f_{bd,fi}(\theta)$ [N/mm ²], $k_{fi}(\theta)$ [-], θ_{max} [°C]
9	Bond strength at increased temperature for post-installed rebar assessed for 100 years: Tensão de aderência para temperaturas para armaduras pós-instaladas avaliadas para 100 anos:	$f_{bd,fi,100y}(\theta)$ [N/mm ²], $k_{fi,100y}(\theta)$ [-], θ_{max} [°C]
10	Characteristic resistance to steel failure for rebar tension anchors under fire exposure: Resistência característica à rotura do aço sob tensão de tração do varão sob exposição ao fogo:	$N_{Rk,s,fi}$ [kN]

Specific Part

1 Technical description of the product

The subject of this European Technical Assessment is the post-installed connection, by anchoring or overlap connection joint, of reinforcing bars (rebars) in existing structures made of normal weight concrete, using the "Rebar connection with injection system FIS RC II" in accordance with the regulations for reinforced concrete construction.

Reinforcing bars made of steel with a diameter ϕ from 8 to 40 mm or the fischer rebar anchor FRA or FRA HCR of sizes M12 to M24 according to Annex A and injection mortar FIS RC II are used for rebar connections. The rebar is placed into a drilled hole filled with injection mortar and is anchored via the bond between rebar, injection mortar and concrete.

The product description is given in Annex A.

2 Specification of the intended use in accordance with the applicable European assessment Document

The performances given in Section 3 are only valid if the rebar connection is used in compliance with the specifications and conditions given in Annex B.

The verifications and assessment methods on which this European Technical Assessment is based lead to the assumption of a working life of the rebar connections of at least 50 and/or 100 years. The indications given on the working life cannot be interpreted as a guarantee given by the producer, but are to be regarded only as a means for choosing the right products in relation to the expected economically reasonable working life of the works.

3 Performance of the product and references to the methods used for its assessment

3.1 Mechanical resistance and stability (BWR 1)

Essential characteristic	Performance
Characteristic resistance under static and quasi-static loading	See Annex C 1, C 2 and C 5
Characteristic resistance under seismic loading	See Annex B 5, C 3 and C 4

3.2 Safety in case of fire (BWR 2)

Essential characteristic	Performance
Reaction to fire	Class A1
Resistance to fire	See Annex C 5 and C 6

4 Assessment and verification of constancy of performance (AVCP) system applied, with reference to its legal base

In accordance with European Assessment Document EAD No. 330087-01-0601, the applicable European legal act is: [96/582/EC].

The system to be applied is: 1

Installation conditions and application examples reinforcing bars, part 1

Figure A1.1:

Overlap joint with existing reinforcement for rebar connections of slabs and beams

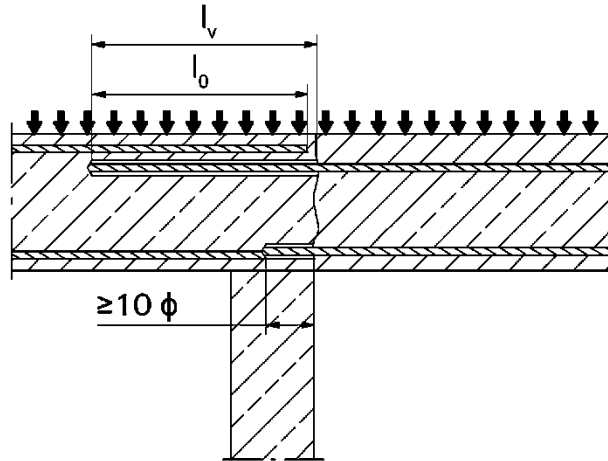

Figure A1.2:

Overlap joint with existing reinforcement at a foundation of a column or wall where the rebars are stressed

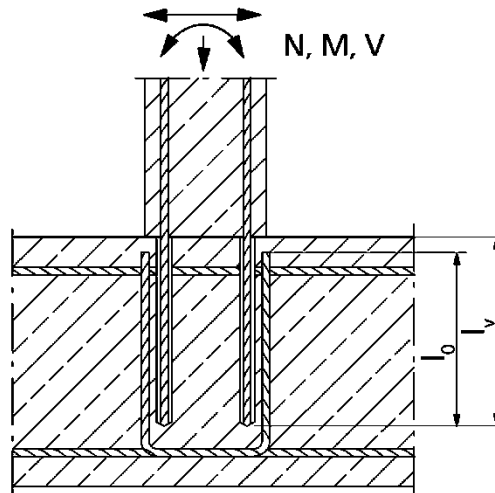
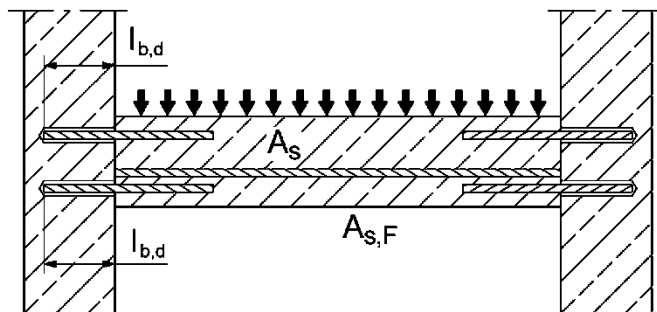

Figure A1.3:

End anchoring of slabs or beams (e.g. designed as simply supported)



Figures not to scale

Rebar connection with injection system FIS RC II

Product description

Installation conditions and application examples reinforcing bars, part 1

Annex A1

Appendix 2 / 24

Installation conditions and application examples reinforcing bars, part 2

Figure A2.1:

Rebar connection for stressed primarily in compression

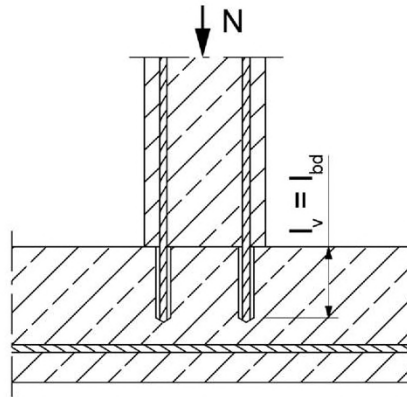
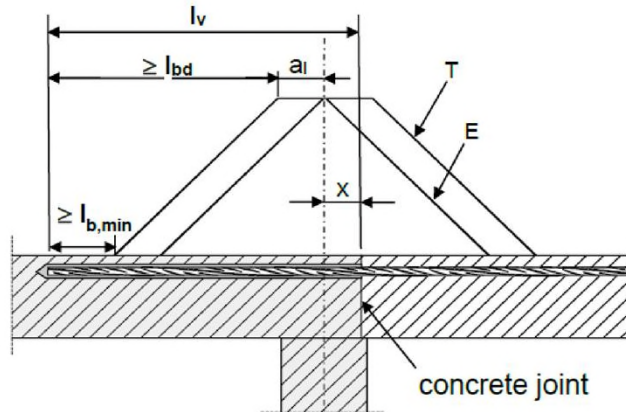

Figure A2.2:

Anchoring of reinforcement to cover the enveloped line of acting tensile force in the bending member



(only post-installed rebar is plotted)

Key to Figure

- T Acting tensile force
- E Envelope of $M_{ed} / z + N_{ed}$ (see EN 1992-1-1:2011)
- x Distance between the theoretical point of support and concrete joint

Note to **figure A1.1 to A1.3** and **figure A2.1 to A2.2**

In the figures no traverse reinforcement is plotted, the transverse reinforcement as required by EN 1992-1-1:2011 shall be present.

The shear transfer between old and new concrete shall be designed according to EN 1992-1-1:2011

Preparation of joints according to **Annex B 3** of this document.

Figures not to scale

Rebar connection with injection system FIS RC II

Product description

Installation conditions and application examples reinforcing bars, part 2

Annex A2

Appendix 3 / 24

Installation conditions and application examples fischer rebar anchor FRA

Figure A3.1:

Lap to a foundation of a column under bending.

1. Shear lug (or fastener loaded in shear)
2. fischer rebar anchor FRA (tension only)
3. Existing stirrup / reinforcement for overlap (lap splice)
4. Slotted hole

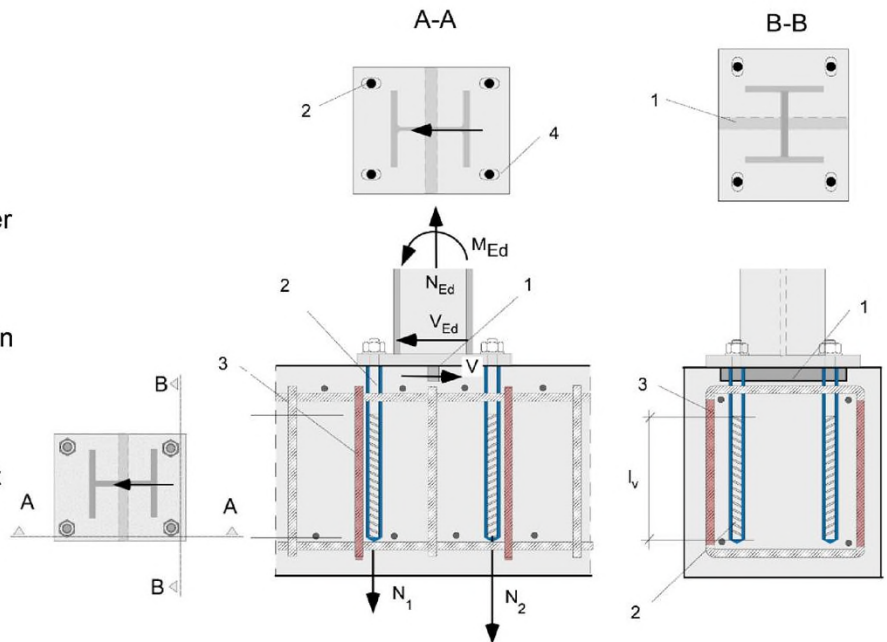
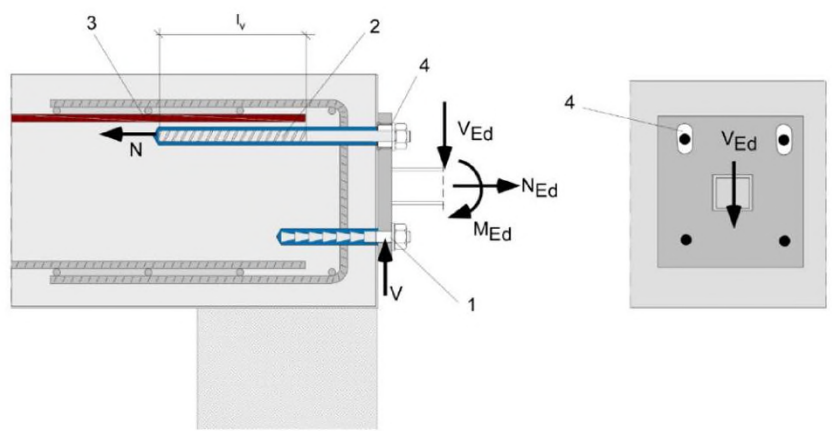

Figure A3.2:

Lap of the anchoring of guardrail posts or anchoring of cantilevered building components. In the anchor plate, the drill holes for the fischer rebar anchors FRA have to be designed as slotted holes with axial direction to the shear force.

1. Fastener for shear load transfer
2. fischer rebar anchor FRA (tension only)
3. Existing stirrup / reinforcement for overlap (lap splice)
4. Slotted hole



The required transverse reinforcement acc. to EN 1992-1-1:2011 is not shown in the figures. **The fischer rebar anchor FRA may be only used for axial tensile force.** The tensile force must be transferred by lap to the existing reinforcement of the building. The transfer of the shear force has to be ensured by suitable measure, e.g. by means of shear force or anchors with European Technical Assessment (ETA).

Figures not to scale

Rebar connection with injection system FIS RC II

Product description

Installation conditions and application examples fischer rebar anchors FRA

Annex A3

Appendix 4 / 24

Overview system components

Injection cartridge (shuttle cartridge) FIS RC II with sealing cap; Sizes: 360 ml, 825 ml

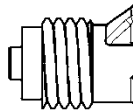
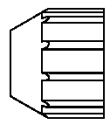

Imprint: fischer FIS RC II, processing notes, shelf-life, hazard code, curing times and processing times (depending on temperature), piston travel scale (optional), size, volume



Injection cartridge (coaxial cartridge) FIS RC II with sealing cap; Sizes: 300 ml, 380 ml, 400 ml, 410 ml

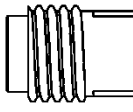
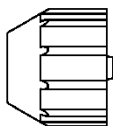

Imprint: fischer FIS RC II, processing notes, shelf-life, hazard code, curing times and processing times (depending on temperature), piston travel scale (optional), size, volume



Static mixer FIS MR Plus for injection cartridges up to 410 ml

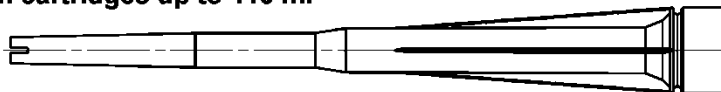

Static mixer FIS JMR for injection cartridges 825 ml

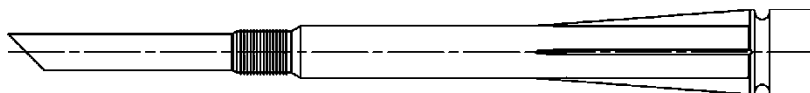

**Injection adapter and extension tube Ø 9 for static mixer FIS MR Plus;
Injection adapter and extension tube Ø 9 or Ø 15 for static mixer FIS JMR**

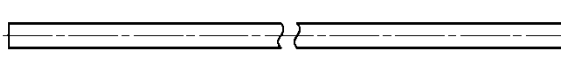
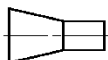

Reinforcing bar (rebar) Sizes: $\phi 8$, $\phi 10$, $\phi 12$, $\phi 14$, $\phi 16$, $\phi 18$, $\phi 20$, $\phi 22$, $\phi 24$, $\phi 25$, $\phi 28$, $\phi 30$, $\phi 32$, $\phi 40$



fischer rebar anchor FRA / FRA HCR Sizes: M12, M16, M20, M24

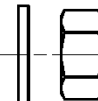

Blow out pump AB G



Compressed-air cleaning tool ABP with fischer compressed-air nozzle

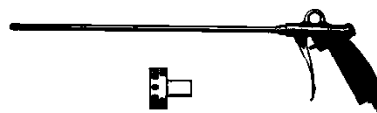

Figures not to scale

Rebar connection with injection system FIS RC II

Product description

Overview system components; Injection mortar, static mixer, injection adapter, reinforcing bar, fischer rebar anchor FRA, cleaning tools

Annex A4

Appendix 5 / 24

Properties of reinforcing bars (rebar)

Figure A5.1:



- The minimum value of related rib area $f_{R,min}$ according to EN 1992-1-1:2011
- The maximum outer rebar diameter over the ribs shall be:
 - The nominal diameter of the bar with rib $\phi + 2 \cdot h$ ($h \leq 0,07 \cdot \phi$)
 - (ϕ : Nominal diameter of the bar; h_{rib} = rib height of the bar)

Table A5.1: Installation conditions for rebars

Nominal diameter of the bar	ϕ	8 ¹⁾	10 ¹⁾	12 ¹⁾	14	16	18	20	22	24	25 ¹⁾	28	30	32	40				
Nominal drill hole diameter	d_0	10	12	12	14	14	16	18	20	25	25	30	30	30	35	35	40	40	55
Drill hole depth	h_0	$h_0 = l_v$																	
Effective embedment depth	l_v	acc. to static calculation																	
Minimum thickness of concrete member	h_{min}	$l_v + 30$ (≥ 100)					$l_v + 2d_0$												

¹⁾ Both drill hole diameters can be used.

Table A5.2: Materials of rebars

Designation	Reinforcing bar (rebar)
Reinforcing bar EN 1992-1-1:2011, Annex C	Bars and de-coiled rods class B or C with f_{yk} and k according to NDP or NCI of EN 1992-1-1/NA $f_{uk} = f_{tk} = k \cdot f_{yk}$

Figures not to scale

Rebar connection with injection system FIS RC II

Product description
Properties and materials of reinforcing bars (rebar)

Annex A5

Appendix 6 / 24

Properties of fischer rebar anchors FRA

Figure A6.1:

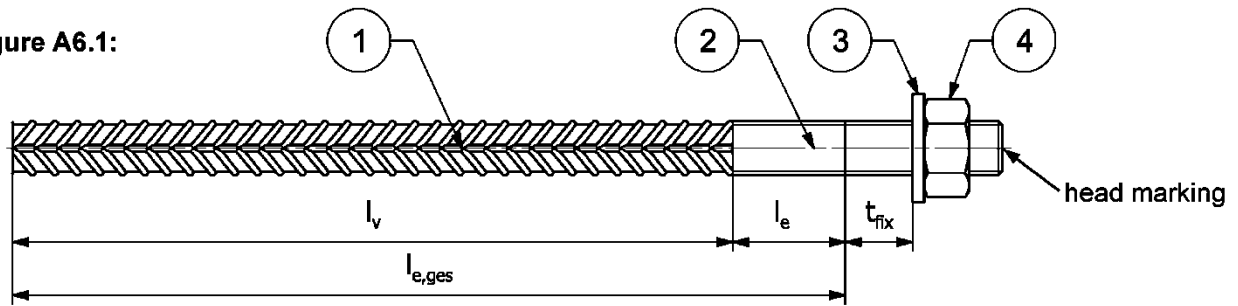

Head marking e.g.:  FRA (for stainless steel)

 FRA HCR (for high corrosion-resistant steel)

Table A6.1: Installation conditions for fischer rebar anchors FRA

Thread diameter		M12 ²⁾	M16	M20	M24 ²⁾
Nominal diameter	ϕ [mm]	12	16	20	25
Nominal drill bit diameter	d_0 [mm]	14 16	20	25	30 35
Drill hole depth ($h_0 = l_{e,ges}$)	$l_{e,ges}$ [mm]	$l_v + l_e$			
Effective embedment depth	l_v [mm]	according to static calculation			
Distance concrete surface to welded joint	l_e [mm]	100			
Maximum Diameter of clearance hole in the fixture ¹⁾	Pre-positioned d_f [mm]	14	18	22	26
	Push through d_f [mm]	16 18	22	26	32 40
Minimum thickness of concrete member	h_{min} [mm]	$h_0 + 30$	$h_0 + 2d_0$		
Maximum torque moment for attachment of the fixture	$\max T_{inst}$ [Nm]	50	100	150	150

¹⁾ For bigger clearance holes in the fixture see EN 1992-4:2018.

²⁾ Both drill bit diameters can be used.

Table A6.2: Materials of fischer rebar anchors FRA

Part	Description	Materials	
		FRA Corrosion resistance class CRC III acc. to EN 1993-1-4:2006+A1:2015	FRA HCR Corrosion resistance class CRC V acc. to EN 1993-1-4: 2006+A1:2015
1	Reinforcing bar	Bars and de-coiled rods class B or C with f_{yk} and k according to NDP or NCI of EN 1992-1-1:NA; $f_{uk} = f_{tk} = k \cdot f_{yk}$; ($f_{yk} = 500 \text{ N/mm}^2$)	
2	Round bar with partial or full thread	Stainless steel, strength class 80, according to EN 10088-1:2014	Stainless steel, strength class 80, according to EN 10088-1:2014
3	Washer ISO 7089:2000	Stainless steel, according to EN 10088-1:2014	Stainless steel, according to EN 10088-1:2014
4	Hexagon nut	Stainless steel, strength class 80, acc. to EN ISO 3506-2:2020, according to EN 10088-1:2014	Stainless steel, strength class 80, acc. to EN ISO 3506-2:2020, according to EN 10088-1:2014

Figures not to scale

Rebar connection with injection system FIS RC II





Product description
Properties and materials of fischer rebar anchors FRA

Annex A6

Appendix 7 / 24

Specifications of intended use part 1

Table B1.1: Overview use and performance categories

Anchorages subject to		FIS RC II with ...			
		Reinforcing bar	fischer rebar anchor FRA		
					
Hammer drilling or compressed air drilling with standard drill bit		all sizes			
Hammer drilling with hollow drill bit (fischer "FHD", Heller "Duster Expert", Bosch "Speed Clean", Hilti "TE-CD, TE-YD")		Nominal drill bit diameter (d_0) 12 mm to 35 mm			
Use category	I1 dry or wet concrete	all sizes			
Characteristic resistance under static and quasi static loading, in	uncracked concrete	all sizes	Tables: C1.1 C1.2 C1.3 C2.1 C2.2 C2.3	all sizes	Tables: C1.1 C1.2 C1.3 C2.1 C2.2 C2.3 C5.1 C5.2
	cracked concrete				
Characteristic resistance under seismic loading		all sizes	Tables: C3.1 C3.2 C3.3 C4.1 C4.2 C4.3	No performance assessed	
Installation direction	D3 (downward and horizontal and upwards (e.g. overhead))				
Installation temperature	$T_{i,min} = -10\text{ °C}$ to $T_{i,max} = +40\text{ °C}$				
Service temperature	Temperature range	-40 °C to +80 °C		(max. short term temperature +80 °C; max long term temperature +50 °C)	
Resistance to fire	all sizes	Annex C6	all sizes	Table C5.3	
Rebar connection with injection system FIS RC II					Annex B1 Appendix 8 / 24
Intended use Specifications part 1					

Specifications of intended use part 2

Anchorage subject to:

- Static and quasi-static loading: reinforcing bar (rebar) size 8 mm to 40 mm; FRA M12 to M24.
- Characteristic resistance under seismic loading: reinforcing bar (rebar) size 8 mm to 40 mm.
- 50 and 100 years working life under seismic loading: reinforcing bar (rebar) size 8 mm to 40 mm.
- Resistance to fire: reinforcing bar (rebar) size 8 mm to 40 mm; FRA M12 to M24.

Base materials:

- Compacted reinforced or unreinforced normal weight concrete without fibres according to EN 206:2013+A1:2016.
- Concrete strength classes C12/15 to C50/60 according to EN 206:2013+A1:2016.
- Maximum chloride content of 0,40 % (CL 0.40) related to the cement content according to EN 206:2013+A1:2016.
- Non-carbonated concrete
Note: In case of a carbonated surface of the existing concrete structure the carbonated layer shall be removed in the area of the post-installed rebar connection with a diameter of $\phi + 60$ mm prior to the installation of the new rebar. The depth of concrete to be removed shall correspond to at least the minimum concrete cover in accordance with EN 1992-1-1:2011. The foregoing may be neglected if building components are new and not carbonated and if building components are in dry conditions.

Use conditions (Environmental conditions) for fischer rebar anchors FRA

- For all conditions according to EN1993-1-4:2006+A1:2015 corresponding to corrosion resistance classes to **Annex A6 Table A6.2**.

Design:

- Fastenings are designed under the responsibility of an engineer experienced in fastenings and concrete work.
- Verifiable calculation notes and drawings are prepared taking account of the forces to be transmitted.
- Design according to EN 1992-1-1:2011; EN 1992-1-2:2011 and **Annex B3 and B4**.
- The actual position of the reinforcement in the existing structure shall be determined on the basis of the construction documentation and taken into account when designing.

Installation:

- The installation of post-installed rebar respectively fischer rebar anchor FRA shall be done only by suitable trained installer and under Supervision on site; the conditions under which an installer may be considered as suitable trained and the conditions for Supervision on site are up to the Member States in which the installation is done.
- Check the position of the existing rebars (if the position of existing rebars is not known, it shall be determined using a rebar detector suitable for this purpose as well as on the basis of the construction documentation and then marked on the building component for the overlap joint).

Rebar connection with injection system FIS RC II

Intended use
Specifications part 2

Annex B2

Appendix 9 / 24

General construction rules for post-installed rebars

Figure B3.1:

- Only tension forces in the axis of the rebar may be transmitted.
- The transfer of shear forces between new concrete and existing structure shall be designed additionally according to EN 1992-1-1:2011.
- The joints for concreting must be roughened to at least such an extent that aggregate protrude.

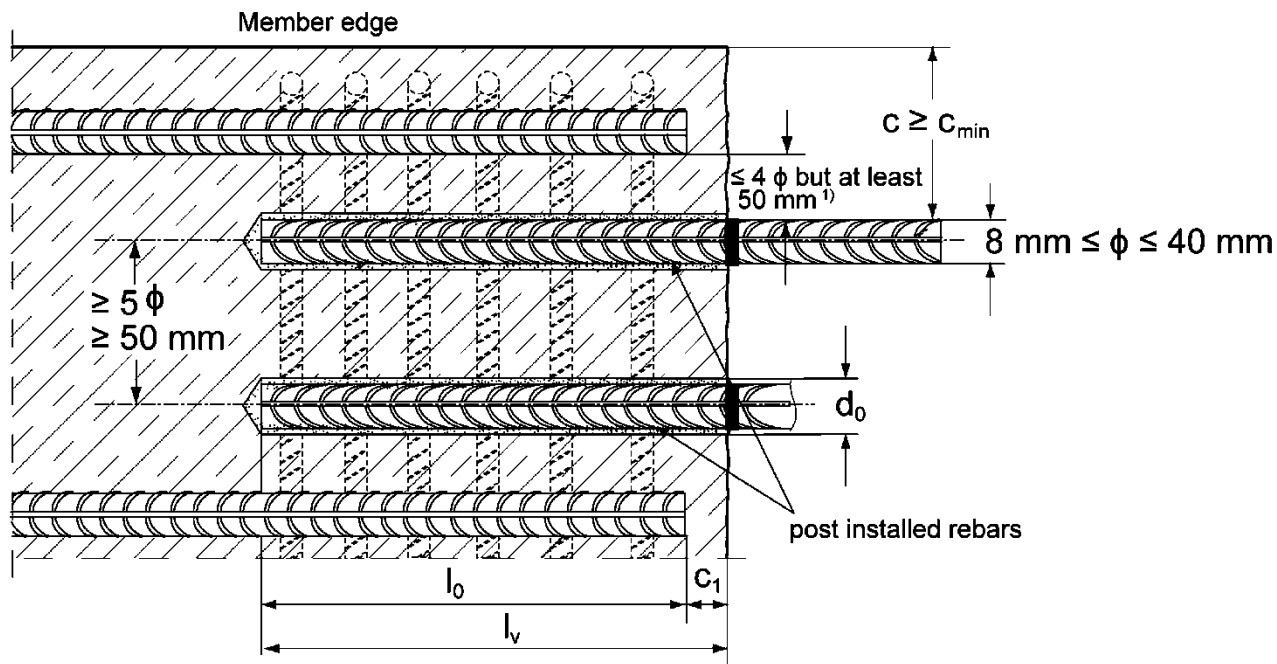

¹⁾ If the clear distance between lapped bars exceeds 4ϕ but at least 50 mm then the lap length shall be increased by the difference between the clear bar distance and 4ϕ but at least 50 mm .

- c concrete cover of post-installed rebar
 c_1 concrete cover at end-face of existing rebar
 c_{\min} minimum concrete cover according to **Table B5.1** and to EN 1992-1-1:2011, Section 4.4.1.2
 ϕ nominal diameter of reinforcing bar
 l_0 lap length, according to EN 1992-1-1:2011 for static loading and according to EN 1998-1: 2004+AC:2009, section 5.6.3 for seismic action
 l_v effective embedment depth, $\geq l_0 + c_1$
 d_0 nominal drill bit diameter, see **Annex B6**

Figures not to scale

Rebar connection with injection system FIS RC II

Intended use
 General construction rules for post-installed rebars

Annex B3

Appendix 10 / 24

General construction rules for post-installed fischer rebar anchors FRA

Figure B4.1:

- Only tension forces in the axis of the fischer rebar anchor FRA may be transmitted.
- The tension force must be transferred via an overlap joint to the reinforcement in the building part.
- The transmission of the shear load shall be ensured by appropriate additional measures, e.g. by shear lugs or by anchors with a European Technical Assessment (ETA).
- In the anchor plate, the holes for the tension anchor shall be executed as slotted holes with the axis in the direction of the shear force.

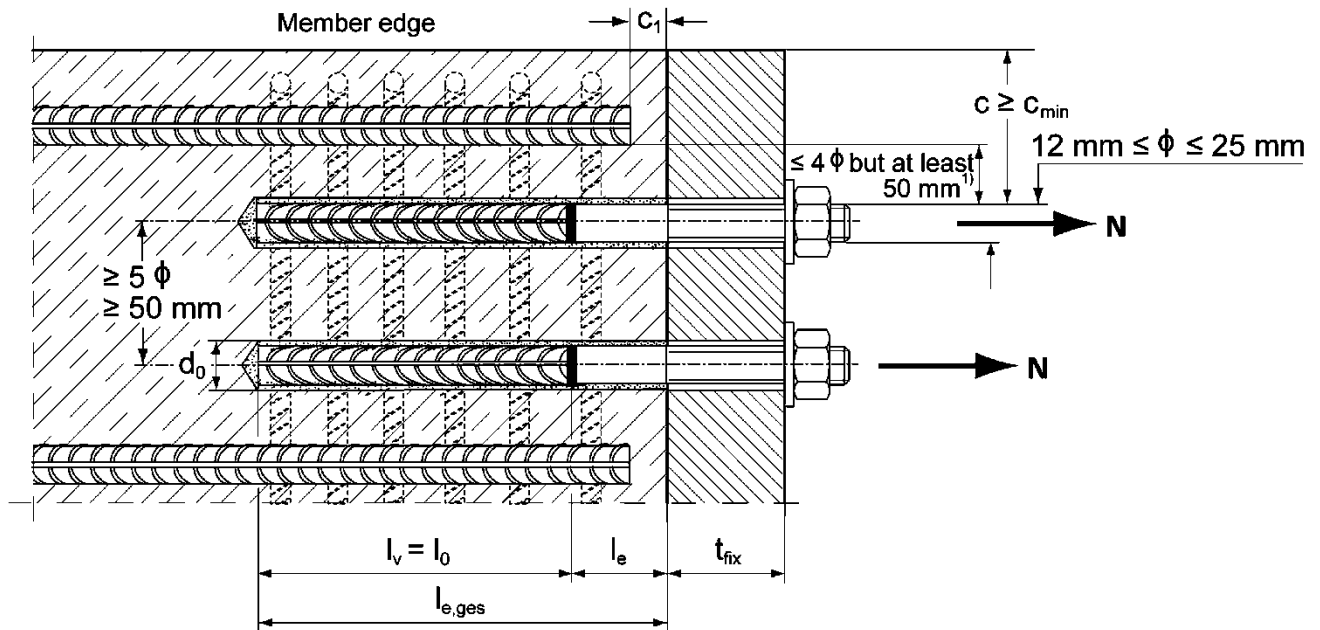

- ¹⁾ If the clear distance between lapped bars exceeds 4ϕ but at least 50 mm then the lap length shall be increased by the difference between the clear bar distance and 4ϕ but at least 50 mm.

c	concrete cover of post-installed fischer rebar anchor FRA
c_1	concrete cover at end-face of existing rebar
C_{min}	minimum concrete cover according to Table B5.1 and to EN 1992-1-1:2011, Section 4.4.1.2
ϕ	nominal diameter of reinforcing bar
l_0	lap length, according to EN 1992-1-1:2011, Section 8.7.3
$l_{e,ges}$	overall embedment depth, $\geq l_0 + l_e$
d_0	nominal drill bit diameter, see Annex B6
l_e	length of the bonded in threaded part
t_{fix}	thickness of the fixture
l_v	effective embedment depth

Figures not to scale

Rebar connection with injection system FIS RC II

Intended use

General construction rules for post-installed fischer rebar anchors FRA

Annex B4

Appendix 11 / 24

Table B5.1: Minimum concrete cover $c_{min}^{1)}$ depending of the drilling method and the drilling tolerance

Drilling method	nominal diameter of reinforcing bar ϕ [mm]	Minimum concrete cover c_{min}	
		Without drilling aid ²⁾ [mm]	With drilling aid ²⁾ [mm]
Hammer drilling with standard drill bit or hollow drill bit	< 25	30 mm + 0,06 $l_v \geq 2 \phi$	30 mm + 0,02 $l_v \geq 2 \phi$
	≥ 25	40 mm + 0,06 $l_v \geq 2 \phi$	40 mm + 0,02 $l_v \geq 2 \phi$
Compressed air drilling	< 25	50 mm + 0,08 l_v	50 mm + 0,02 l_v
	≥ 25	60 mm + 0,08 $l_v \geq 2 \phi$	60 mm + 0,02 $l_v \geq 2 \phi$

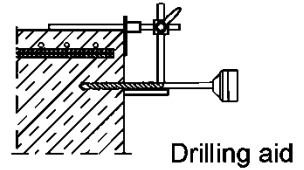

¹⁾ See Annex B3, figure B3.1 and Annex B4, figure B4.1

Note: The minimum concrete cover as specified in EN 1992-1-1:2011 must be observed. The same minimum concrete covers apply to rebar elements in case of seismic loading. $c_{min,seis} = 2 \phi$.

²⁾ For FRA (HCR) $l_{e,ges}$ instead of l_v .

Table B5.2: Dispensers and cartridge sizes corresponding to maximum embedment depth $l_{v,max}$

reinforcing bars (rebar)	fischer rebar anchor FRA	Manual dispenser	Accu and pneumatic dispenser (small)	Accu and pneumatic dispenser (large)
		Cartridge size		
ϕ [mm]	thread [-]	< 500 ml	> 500 ml	
		$l_{v,max} / l_{e,ges,max}$ [mm]		$l_{v,max} / l_{e,ges,max}$ [mm]
8	---	1000	1000	1800
10	---		1200	
12	FRA M12 FRA HCR M12			
14	---			
16	FRA M16 FRA HCR M16	700	1300	2000
18, 20, 22, 24	FRA M20 FRA HCR M20		1000	
25	FRA M24 FRA HCR M24			
28	---	700	700	$T_i > 0 \text{ }^\circ\text{C}: 1500$ $T_i \leq 0 \text{ }^\circ\text{C}: 2000$
30, 32	---	700	700	
40	---	700	700	1200

Table B5.3: Conditions for use static mixer without an extension tube

Nominal drill hole diameter	d_0	[mm]	10	12	14	16	18	20	24	25	30	35	40	55
			Drill hole depth h_0 by using	FIS MR Plus	≤ 90	≤ 120	≤ 140	≤ 150	≤ 160	≤ 190	≤ 210			
	FIS JMR	-	-	≤ 90	≤ 160	≤ 180	≤ 190	≤ 220		≤ 250				

Rebar connection with injection system FIS RC II

Intended use
Minimum concrete cover;
dispenser and cartridge sizes corresponding to maximum embedment depth

Annex B5

Appendix 12 / 24

Table B6.1: Working times t_{work} and curing times t_{cure}

Temperature in the anchorage base [°C]	Maximum working time ¹⁾ t_{work} FIS RC II	Minimum curing time ²⁾ t_{cure} FIS RC II
-10 to 0	20 min ³⁾	12 h
> 0 to 5	13 min ³⁾	3 h
> 5 to 10	9 min ³⁾	90 min
> 10 to 20	5 min	60 min
> 20 to 30	4 min	45 min
> 30 to 40	2 min ⁴⁾	35 min

1) Maximum time from the beginning of the injection to rebar / fischer rebar anchor FRA setting and positioning.

2) For wet concrete the curing time must be doubled.

3) If the temperature in the concrete falls below 10 °C the cartridge must be warmed up to +15 °C.

4) If the temperature in the concrete exceeds 30 °C the cartridge must be cooled down to +15 °C up to 20 °C.

Table B6.2: Installation tools for drilling and cleaning the bore hole and injection of the mortar

reinforcing bars (rebar) ϕ [mm]	fischer rebar anchor FRA Designation	Drilling and cleaning				Injection	
		Nominal drill bit diameter d_0 [mm]	Diameter of cutting edge d_{cut} [mm]	Steel brush diameter d_b [mm]	Diameter of fischer compressed-air nozzle [mm]	Diameter of extension tube [mm]	Injection adapter [colour]
8 ¹⁾	---	10	$\leq 10,50$	11	---	9	---
		12	$\leq 12,50$	12,5	11		nature
10 ¹⁾	---	12	$\leq 12,50$	12,5		15	9
		14	$\leq 14,50$	15	15		
12 ¹⁾	FRA M12 FRA HCR M12	14	$\leq 14,50$	15		19	9 or 15
		16	$\leq 16,50$	17	19		
14	---	18	$\leq 18,50$	19		19	9 or 15
16	FRA M16 FRA HCR M16	20	$\leq 20,55$	21,5	28		
18	FRA M20 FRA HCR M20	25	$\leq 25,55$	26,5		28	9 or 15
20					38		
22	---	30	$\leq 30,55$	32		38	9 or 15
24	---				50		
25 ¹⁾	FRA M24 FRA HCR M2	30	$\leq 30,55$	32		50	15
		35	$\leq 35,70$	37			
28	---	35	$\leq 35,70$	37			
30		40	$\leq 40,70$	42			
32	---						
40	---	55	$\leq 55,80$	58			

1) Both drill bit diameters can be used

Rebar connection with injection system FIS RC II

Intended use

Working times and curing times;
Installation tools for drilling and cleaning the bore hole and injection of the mortar

Annex B6

Appendix 13 / 24

Safety regulations



Review the Safety Data Sheet (SDS) before use for proper and safe handling!
Wear well-fitting protective goggles and protective gloves when working with mortar FIS RC II.
Important: Observe the instructions for use provided with each cartridge.

Installation instruction part 1; Installation with FIS RC II

Hole drilling

Note: Before drilling, remove carbonized concrete; clean contact areas (see **Annex B 2**)
In case of aborted drill holes the drill hole shall be filled with mortar.

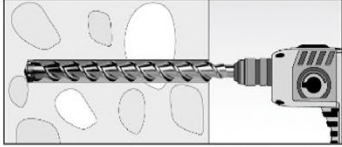
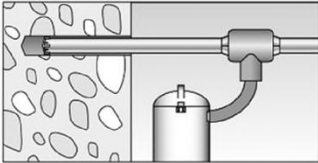
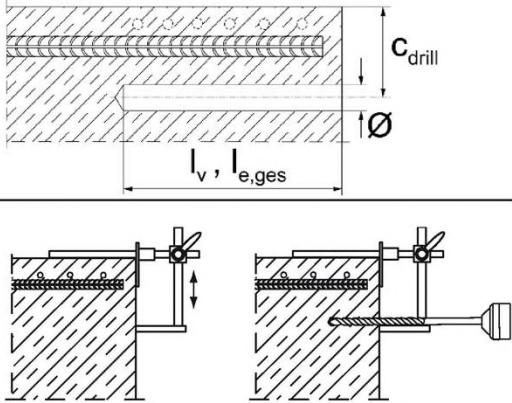
<p>1a</p>	<p>Hammer drilling or compressed air drilling</p> 	<p>Drill the hole to the required embedment depth using a hammer drill with carbide drill bit set in rotation hammer mode or a pneumatic drill. Drill bit sizes see Table B6.2.</p>
<p>1b</p>	<p>Hammer drilling with hollow drill bit</p> 	<p>Drill the hole to the required embedment depth using a hammer drill with hollow drill bit in rotation hammer mode. Dust extraction conditions see drill hole cleaning Annex B8. Drill bit sizes see Table B6.2.</p>
<p>2</p>		<p>Measure and control concrete cover c ($c_{\text{drill}} = c + \varnothing / 2$) Drill parallel to surface edge and to existing rebar. Where applicable use drilling aid.</p> <p>For holes $l_v > 20$ cm use drilling aid. Three different options can be considered:</p> <ul style="list-style-type: none"> A) drilling aid B) Slat or spirit level C) Visual check <p>Minimum concrete cover c_{min} see Table B5.1.</p>

Rebar connection with injection system FIS RC II

Intended use
Safety regulations; Installation instruction part 1, hole drilling

Annex B7

Appendix 14 / 24

Installation instruction part 2; Installation with FIS RC II

Drill hole cleaning

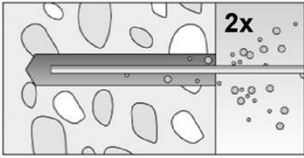
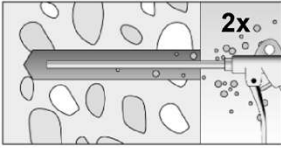
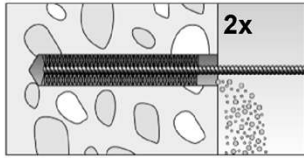
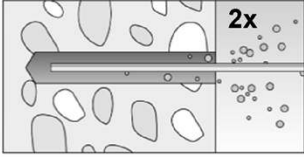
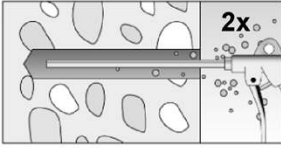
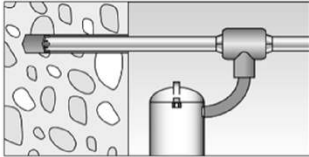
		Hammer or compressed air drilling		
3a		Clean the drill hole: For $d_0 < 18$ mm and depths l_v resp. $l_{e,ges} \leq 12 \cdot \phi$ blow out the hole two times by hand.		For $d_0 \geq 18$ mm and depths l_v resp. $l_{e,ges} > 12 \cdot \phi$ blow out the hole two times with oil-free compressed air ($p \geq 6$ bar). Use suitable compressed-air nozzle (see Table B6.2).
		Brush drill hole two times; for drill hole diameters $d_0 \geq 30$ mm attach brush to a power tool and brush hole with a speed of max. 550 revolutions per minute. For deep holes a brush extension is mandatory. Use suitable brushes (see Table B6.2).		
		Clean the drill hole: For $d_0 < 18$ mm and depths l_v resp. $l_{e,ges} \leq 12 \cdot \phi$ blow out the hole two times by hand.		For $d_0 \geq 18$ mm and depths l_v resp. $l_{e,ges} > 12 \cdot \phi$ blow out the hole two times with oil-free compressed air ($p \geq 6$ bar) Use suitable compressed-air nozzle (see Table B6.2).
			Hammer drilling with hollow drill bit	
3b		Use a suitable dust extraction system, e. g. fischer FVC 35 M or a comparable dust extraction system with equivalent performance data. Drill the hole with hollow drill bit. The dust extraction system has to extract the drill dust nonstop during the drilling process and must be adjusted to maximum power. No further drill hole cleaning necessary.		

Rebar connection with injection system FIS RC II

Intended use
Installation instruction part 2, drill hole cleaning

Annex B8

Appendix 15 / 24

Installation instruction part 3; Installation with FIS RC II

reinforcing bars (rebar) / fischer rebar anchor FRA and cartridge preparation

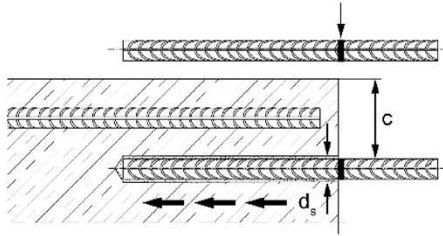
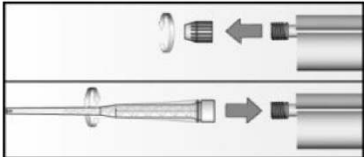
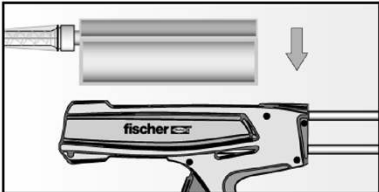
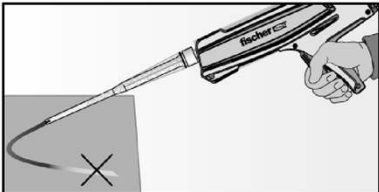
4		<p>Before use, ensure that the rebar or the fischer rebar anchor FRA is dry and free of oil or other residue. Mark the embedment depth l_v (e.g. with tape) Insert rebar in borehole, to verify drill hole depth and setting depth l_v resp. $l_{e,ges}$.</p>
5		<p>Twist off the sealing cap Twist on the static mixer (the spiral in the static mixer must be clearly visible).</p>
6		<p>Place the cartridge into a suitable dispenser.</p>
7		<p>Press out approximately 10 cm of mortar until the resin is permanently grey in colour. Mortar which is not grey in colour will not cure and must be disposed.</p>

Rebar connection with injection system FIS RC II

Intended use



Installation instruction part 3,
reinforcing bars (rebar) / fischer rebar anchor FRA and cartridge preparation

Annex B9

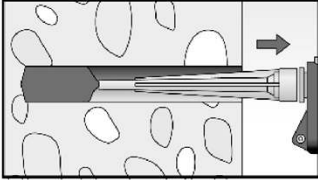

Appendix 16 / 24

Installation instruction part 4; Installation with FIS RC II

Injection of the mortar without extension tube

8a		<p>Inject the mortar from the back of the hole towards the front and slowly withdraw the static mixer step by step with each trigger pull. Avoid bubbles. Fill holes approximately 2/3 full, to ensure that the annular gap between the rebar and the concrete will be completely filled with adhesive over the entire embedment length. The conditions for mortar injection without extension tube can be found in Table B5.3.</p>
		<p>After injecting, release the dispenser. This will prevent further mortar discharge from the static mixer.</p>

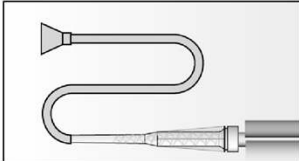
Injection of the mortar with extension tube

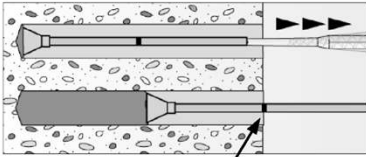
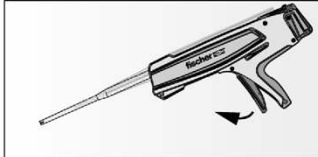
		<p>Assemble mixing nozzle FIS MR Plus or FIS JMR, extension tube and appropriate injection adapter (see Table B6.2).</p>
8b	<p>Mortar level mark</p> 	<p>Mark the required mortar level l_m and embedment depth l_v resp. $l_{e,ges}$ with tape or marker on the injection extension tube.</p> <p>a) Estimation:</p> $l_m = \frac{1}{3} \cdot l_v \text{ resp. } l_m = \frac{1}{3} \cdot l_{e,ges} \text{ [mm]}$ <p>b) Precise equation for optimum mortar volume:</p> $l_m = l_v \text{ resp. } l_{e,ges} \left(\left(1,2 \cdot \frac{d_s^2}{d_0^2} - 0,2 \right) \right) \text{ [mm]}$
	 <p>Mortar level mark</p>	<p>Insert injection adapter to back of the hole. Begin injection allowing the pressure of the injected adhesive mortar to push the injection adapter towards the front of the hole. Do not actively pull out! Fill holes approximately 2/3 full, to ensure that the annular gap between the rebar and the concrete will be completely filled with adhesive over the embedment length. When using an injection adapter continue injection until the mortar level mark l_m becomes visible. Maximum embedment depth see Table B5.2.</p>
		<p>After injecting, release the dispenser. This will prevent further mortar discharge from static mixer.</p>

Rebar connection with injection system FIS RC II

Intended use



Installation instruction part 4, mortar injection

Annex B10

Appendix 17 / 24

Installation instruction part 5; Installation with FIS RC II

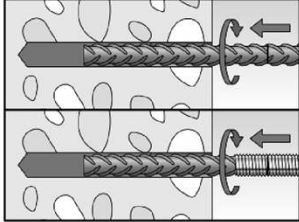
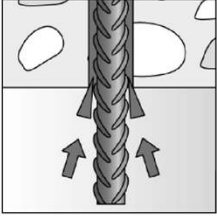
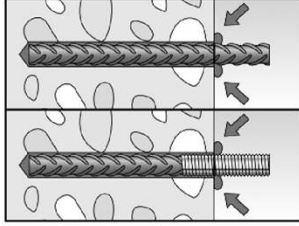
Insert rebar / fischer rebar anchor FRA

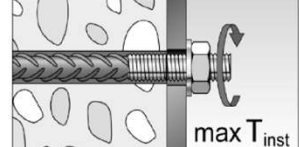
9		<p>Insert the rebar / fischer rebar anchor FRA slowly twisted into the borehole until the embedment mark is reached.</p> <p>Recommendation: Rotation back and forth of the reinforcement bar or the fischer rebar anchor FRA makes pushing easy.</p>
10		<p>For overhead installation, support the rebar / fischer rebar anchor FRA and secure it from falling till mortar started to harden, e.g. using wedges.</p>
11		<p>After installing the rebar or fischer rebar anchor FRA the annular gap must be completely filled with mortar.</p> <p>Proper installation</p> <ul style="list-style-type: none"> • Desired embedment depth is reached l_v, resp. $l_{e,ges}$: embedment mark at concrete surface • Excess mortar flows out of the borehole after the rebar has been fully inserted up to the embedment mark.
12		<p>Observe the working time "t_{work}" (see Table B6.1), which varies according to temperature of base material. Minor adjustments to the rebar / fischer rebar anchor FRA position may be performed during the working time "t_{work}".</p> <p>Full load may be applied only after the curing time "t_{cure}" has elapsed (see Table B 6.1).</p>
13		<p>Mounting the fixture for fischer rebar anchor FRA, max T_{inst} see Table A6.1.</p>

Rebar connection with injection system FIS RC II

Intended use

Installation instruction part 5, insert rebar / fischer rebar anchor FRA

Annex B11

Appendix 18 / 24

Minimum anchorage length and minimum lap length for 50 years working life

The minimum anchorage length $l_{b,min}$ and the minimum lap length $l_{o,min}$ according to EN 1992-1-1:2011 shall be multiplied by the relevant amplification factor α_{lb} according to **Table C1.1**.

Table C1.1: Amplification factor α_{lb} related to concrete strength class and drilling method

Hammer drilling, hollow drilling and compressed air drilling										
Rebar / fischer rebar anchor FRA	Amplification factor α_{lb}									
	Concrete strength class									
ϕ [mm]	C12/15	C16/20	C20/25	C25/30	C30/37	C35/45	C40/50	C45/55	C50/60	
8 - 25	1,00						1,10		1,20	
28 - 32	1,00									
40	1,0			1,07	1,22	1,23	1,24	1,26	1,27	

Table C1.2: Bond efficiency factor k_b related to concrete strength class and drilling method

Hammer drilling, hollow drilling and compressed air drilling										
Rebar / fischer rebar anchor FRA	Bond efficiency factor k_b									
	Concrete strength class									
ϕ [mm]	C12/15	C16/20	C20/25	C25/30	C30/37	C35/45	C40/50	C45/55	C50/60	
8 - 25	1,00									
28 - 32	1,00						0,91	0,84	0,84	
40	1,00					0,90	0,82	0,76	0,71	

Table C1.3: Design values of the bond strength $f_{bd,PIR}$ in N/mm² related to concrete strength class and drilling method for good bond conditions

$$f_{bd,PIR} = k_b \cdot f_{bd}$$

f_{bd} : Design value of the bond strength in N/mm² considering the concrete strength classes and the rebar diameter for good bond condition (for all other bond conditions multiply the values by $\eta_1 = 0,7$) and recommended partial factor $\gamma_c = 1,5$ according to EN 1992-1-1:2011

k_b : Bond efficiency factor according to **Table C1.2**

Hammer drilling, hollow drilling and compressed air drilling									
Rebar / fischer rebar anchor FRA	Bond strength $f_{bd,PIR}$ [N/mm ²]								
	Concrete strength class								
ϕ [mm]	C12/15	C16/20	C20/25	C25/30	C30/37	C35/45	C40/50	C45/55	C50/60
8 - 25	1,6	2,0	2,3	2,7	3,0	3,4	3,7	4,0	4,3
28 - 32	1,6	2,0	2,3	2,7	3,0	3,4	3,4	3,4	3,7
40	1,5	1,8	2,1	2,5	2,8				

Rebar connection with injection system FIS RC II

Performance

Amplification factor α_{lb} , bond efficiency factor k_b , design values of the bond strength $f_{bd,PIR}$

Annex C1

Appendix 19 / 24

Minimum anchorage length and minimum lap length for 100 years working life

The minimum anchorage length $l_{b,min}$ and the minimum lap length $l_{o,min}$ according to EN 1992-1-1:2011 shall be multiplied by the relevant amplification factor $\alpha_{lb,100y}$ according to Table C2.1.

Table C2.1: Amplification factor $\alpha_{lb,100y}$ related to concrete strength class and drilling method

Hammer drilling, hollow drilling and compressed air drilling										
Rebar / fischer rebar anchor FRA ϕ [mm]	Amplification factor $\alpha_{lb,100y}$									
	Concrete strength class									
	C12/15	C16/20	C20/25	C25/30	C30/37	C35/45	C40/50	C45/55	C50/60	
8 - 12	1,00				1,10	1,20	1,20	1,30		
14 - 25	1,00				1,10	1,20	1,20	1,20		
28 - 32	1,00								1,10	
40	1,0	1,02	1,19	1,20	1,21	1,22	1,23	1,25		

Table C2.2: Bond efficiency factor $k_{b,100y}$ related to concrete strength class and drilling method

Hammer drilling, hollow drilling and compressed air drilling										
Rebar / fischer rebar anchor FRA ϕ [mm]	Bond efficiency factor $k_{b,100y}$									
	Concrete strength class									
	C12/15	C16/20	C20/25	C25/30	C30/37	C35/45	C40/50	C45/55	C50/60	
8 - 12	1,00									
14 - 25	1,00							0,92	0,86	
28 - 32	1,00			0,90	0,90	0,82	0,76	0,76		
40	1,00			0,89	0,80	0,73	0,67	0,63		

Table C2.3: Design values of the bond strength $f_{bd,PIR,100y}$ in N/mm² related to concrete strength class and drilling method for good bond conditions

$$f_{bd,PIR,100y} = k_{b,100y} \cdot f_{bd}$$

f_{bd} : Design value of the bond strength in N/mm² considering the concrete strength classes and the rebar diameter for good bond condition (for all other bond conditions multiply the values by $\eta_1 = 0,7$) and recommended partial factor $\gamma_c = 1,5$ according to EN 1992-1-1:2011

$k_{b,100y}$: Bond efficiency factor according to Table C2.2

Hammer drilling, hollow drilling and compressed air drilling										
Rebar / fischer rebar anchor FRA ϕ [mm]	Bond strength $f_{bd,PIR,100y}$ [N/mm ²]									
	Concrete strength class									
	C12/15	C16/20	C20/25	C25/30	C30/37	C35/45	C40/50	C45/55	C50/60	
8 - 12	1,6	2,0	2,3	2,7	3,0	3,4	3,7	4,0	4,3	
14 - 25	1,6	2,0	2,3	2,7	3,0	3,4	3,7	3,7	3,7	
28 - 32	1,6	2,0	2,3	2,7	2,7	3,0	3,0	3,0	3,4	
40	1,5	1,8	2,1	2,5						

Rebar connection with injection system FIS RC II

Performance

Amplification factor $\alpha_{lb,seis}$, bond efficiency factor $k_{b,seis}$, Design values of the bond strength $f_{bd,PIR,seis}$

Annex C2

Minimum anchorage length and minimum lap length under seismic conditions for 50 years working life

The minimum anchorage length $l_{b,min}$ and the minimum lap length $l_{o,min}$ according to EN 1992-1-1:2011 shall be multiplied by the relevant amplification factor $\alpha_{lb,seis}$ according to Table C3.1.

Table C3.1: Amplification factor $\alpha_{lb,seis}$ related to concrete strength class and drilling method

Hammer drilling, hollow drilling and compressed air drilling

Rebar ϕ [mm]	Amplification factor $\alpha_{lb,seis}$							
	Concrete strength class							
	C16/20	C20/25	C25/30	C30/37	C35/45	C40/50	C45/55	C50/60
8 - 25	1,0					1,1		1,2
28 - 32	1,0							
40	- ¹⁾	1,0	1,07	1,22	1,23	1,24	1,26	1,27

¹⁾ No performance assessed

Table C3.2: Bond efficiency factor $k_{b,seis}$ for hammer drilling, hollow drilling and compressed air drilling with a service life of 50 years

Hammer drilling, hollow drilling and compressed air drilling

Rebar ϕ [mm]	Bond efficiency factor $k_{b,seis}$							
	Concrete strength class							
	C16/20	C20/25	C25/30	C30/37	C35/45	C40/50	C45/55	C50/60
8 - 25	1,00							
28 - 32	1,00					0,91	0,84	0,84
40	- ¹⁾	1,00	0,86	0,76	0,69	0,63	0,58	0,54

¹⁾ No performance assessed

Table C3.3: Design values of the bond strength $f_{bd,PIR,seis}$ in N/mm² for hammer drilling, hollow drilling and compressed air drilling under seismic action and for good bond conditions with a service life of 50 years

$$f_{bd,PIR,seis} = k_{b,seis} \cdot f_{bd}$$

Hammer drilling, hollow drilling and compressed air drilling

Rebar ϕ [mm]	bond strength $f_{bd,PIR,seis}$ [N/mm ²]							
	Concrete strength class							
	C16/20	C20/25	C25/30	C30/37	C35/45	C40/50	C45/55	C50/60
8 - 25	2,0	2,3	2,7	3,0	3,4	3,7	4,0	4,3
28 - 32	2,0	2,3	2,7	3,0	3,4	3,4	3,4	3,7
40	- ¹⁾	2,1						

¹⁾ No performance assessed

Rebar connection with injection system FIS RC II

Performance

Amplification factor $\alpha_{lb,seis}$, bond efficiency factor $k_{b,seis}$, Design values of the bond strength $f_{bd,PIR,seis}$

Annex C3

Appendix 21 / 24

Minimum anchorage length and minimum lap length under seismic conditions for 100 years working life

The minimum anchorage length $l_{b,min}$ and the minimum lap length $l_{o,min}$ according to EN 1992-1-1:2011 shall be multiplied by the relevant amplification factor $\alpha_{l,b,seis,100y}$ according to Table C4.1.

Table C4.1: Amplification factor $\alpha_{l,b,seis,100y}$ related to concrete strength class and drilling method

Hammer drilling, hollow drilling and compressed air drilling

Rebar ϕ [mm]	Amplification factor $\alpha_{l,b,seis,100y}$							
	Concrete strength class							
	C16/20	C20/25	C25/30	C30/37	C35/45	C40/50	C45/55	C50/60
8 - 12	1,00				1,10	1,20	1,20	1,30
14 - 25	1,00				1,10	1,20	1,20	1,20
28 - 32	1,0							1,10
40	- ¹⁾	1,02	1,19	1,20	1,21	1,22	1,23	1,25

¹⁾ No performance assessed

Table C4.2: Bond efficiency factor $k_{b,seis,100y}$ for hammer drilling, hollow drilling and compressed air drilling with a service life of 100 years

Hammer drilling, hollow drilling and compressed air drilling

Rebar ϕ [mm]	Bond efficiency factor $k_{b,seis,100y}$							
	Concrete strength class							
	C16/20	C20/25	C25/30	C30/37	C35/45	C40/50	C45/55	C50/60
8 - 12	1,00							
14 - 25	1,00						0,92	0,86
28 - 32	1,00			0,90	0,90	0,82	0,76	0,76
40	- ¹⁾	0,86	0,74	0,66	0,59	0,54	0,50	0,47

¹⁾ No performance assessed

Table C4.3: Design values of the bond strength $f_{bd,PIR,seis,100y}$ in N/mm² for hammer drilling, hollow drilling and compressed air drilling under seismic action and for good bond conditions with a service life of 100 years

$$f_{bd,PIR,seis,100y} = k_{b,seis,100y} \cdot f_{bd}$$

Hammer drilling, hollow drilling and compressed air drilling

Rebar ϕ [mm]	bond strength $f_{bd,PIR,seis,100y}$ [N/mm ²]							
	Concrete strength class							
	C16/20	C20/25	C25/30	C30/37	C35/45	C40/50	C45/55	C50/60
8 - 12	2,0	2,3	2,7	3,0	3,4	3,7	4,0	4,3
14 - 25	2,0	2,3	2,7	3,0	3,4	3,7	3,7	3,7
28 - 32	2,0	2,3	2,7	2,7	3,0	3,0	3,0	3,4
40	- ¹⁾	1,8						

¹⁾ No performance assessed

Rebar connection with injection system FIS RC II

Performance

Amplification factor $\alpha_{l,b,seis,100y}$, bond efficiency factor $k_{b,seis,100y}$, Design values of the bond strength $f_{bd,PIR,seis,100y}$

Annex C4

Table C5.1: Characteristic tensile yield strength for rebar part of fischer rebar anchors FRA

fischer rebar anchor FRA / FRA HCR			M12	M16	M20	M24
Characteristic tensile yield strength for rebar part						
Rebar diameter	ϕ	[mm]	12	16	20	25
Characteristic tensile yield strength for rebar	f_{yk}	[N/mm ²]	500	500	500	500
Partial factor for rebar part	$\gamma_{Ms,N}^{1)}$	[-]	1,15			

¹⁾ In absence of national regulations

Table C5.2: Characteristic resistance to steel failure under tension loading of fischer rebar anchors FRA

fischer rebar anchor FRA / FRA HCR			M12	M16	M20	M24
Characteristic resistance to steel failure under tension loading						
Characteristic resistance	$N_{Rk,s}$	[kN]	62	111	173	263
Partial factor						
Partial factor	$\gamma_{Ms,N}^{1)}$	[-]	1,4			

¹⁾ In absence of national regulations

Table C5.3: Characteristics resistance to steel failure for fischer rebar anchors FRA under tension loading and fire exposure R30 to R120

fischer rebar anchor FRA / FRA HCR				M12	M16	M20	M24
Characteristic resistance to steel failure under tension loading and fire exposure	R30	$N_{Rk,s,fi}$	[kN]	2,5	4,7	7,4	10,6
	R60			2,1	3,9	6,1	8,8
	R90			1,7	3,1	4,9	7,1
	R120			1,3	2,5	3,9	5,6

Rebar connection with injection system FIS RC II

Performance

Characteristic tensile yield strength for rebar part of FRA; Design value of the steel bearing capacity $N_{Rk,s,fi}$ under fire exposure for fischer rebar anchor FRA

Annex C5

Design value of the ultimate bond strength $f_{bd,fi}$ resp. $f_{bd,fi,100y}$ at increased temperature for concrete strength classes C12/15 to C50/60 (all drilling methods)

The design value of the bond strength $f_{bd,fi}$ resp. $f_{bd,fi,100y}$ at increased temperature has to be calculated by the following equation:

$$f_{bd,fi,(100y)} = k_{fi,(100y)}(\theta) \cdot f_{bd,PIR,(100y)} \cdot \frac{\gamma_c}{\gamma_{m,fi}}$$

$$\text{If: } \theta > 74 \text{ } ^\circ\text{C} \quad k_{fi,(100y)}(\theta) = \frac{24,308 \cdot e^{-0,012 \cdot \theta}}{f_{bd,PIR,(100y)} \cdot 4,3} \leq 1,0$$

$$\text{If: } \theta > \theta_{\max} (317 \text{ } ^\circ\text{C}) \quad k_{fi}(\theta) = 0$$

- $f_{bd,fi}$ = Design value of the ultimate bond strength at increased temperature in N/mm² for working life 50 years
- $f_{bd,fi,100y}$ = Design value of the ultimate bond strength at increased temperature in N/mm² for working life 100 years
- θ = Temperature in °C in the mortar layer
- $k_{fi}(\theta)$ = Reduction factor at increased temperature for working life 50 years
- $k_{fi,100y}(\theta)$ = Reduction factor at increased temperature for working life 100 years
- $f_{bd,PIR}$ = Design value of the bond strength in N/mm² in cold condition according to **Table C1.3** considering the concrete strength classes, the rebar diameter, the drilling method and the bond conditions according to EN 1992-1-1:2011
- $f_{bd,PIR,100y}$ = Design value of the bond strength in N/mm² in cold condition according to **Table C2.3** considering the concrete strength classes, the rebar diameter, the drilling method and the bond conditions according to EN 1992-1-1:2011
- γ_c = 1,5 recommended partial factor according to EN 1992-1-1:2011
- $\gamma_{m,fi}$ = 1,0 recommended partial factor according to EN 1992-1-2:2011

For evidence at increased temperature the anchorage length shall be calculated according to EN 1992-1-1:2011 Equation 8.3 using the temperature-dependent ultimate design value of bond strength $f_{bd,fi}$ resp. $f_{bd,fi,100y}$.

Figure C6.1: Example graph of reduction factor $k_{fi,(100y)}(\theta)$ for concrete class C20/25 for good bond conditions

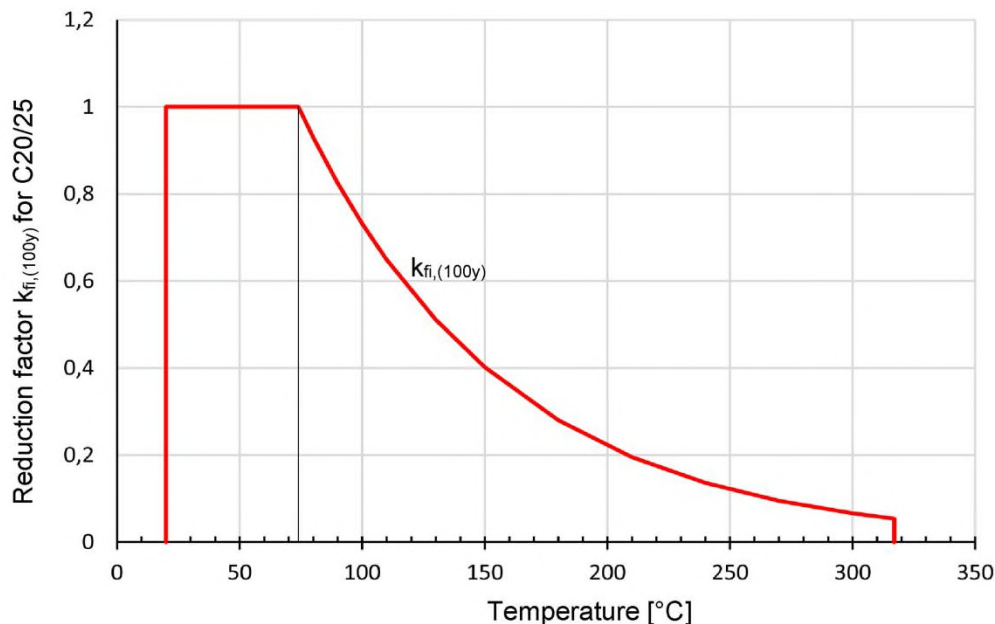

Rebar connection with injection system FIS RC II

Performance

Design value of bond strength $f_{bd,fi}$ resp. $f_{bd,fi,100y}$ at increased temperature

Annex C6

Appendix 24 / 24