

DECLARAÇÃO DE DESEMPENHO

DoP 0394

para sistema de injeção fischer FIS EM PLUS (Âncoras metálicas para utilização em betão)

PT

1. Código de identificação único do produto-tipo: **DoP 0394**
2. Utilização(ões) prevista(s): **Fixação pós-instalada em betão fissurado ou não fissurado, ver anexos, especialmente anexos B1 - B19.**
3. Fabricante: **fischerwerke GmbH & Co. KG, Otto-Hahn-Straße 15, 79211 Denzlingen, Alemanha**
4. Representante autorizado: **-**
5. Sistema(s) de avaliação e verificação da regularidade do desempenho (AVCP): **1**
6. Documento de Avaliação Europeu: **EAD 330499-02-0601-v01**
Avaliação Técnica Europeia: **ETA-17/0979; 2026-02-12**
Organismo de Avaliação Técnica: **DIBt- Deutsches Institut für Bautechnik**
Organismo(s) notificado(s): **2873 TU Darmstadt**
7. Desempenho(s) declarado(s):
Resistência mecânica e estabilidade (BWR 1)
Características de resistência à tração (para acção estática e quase-estática):
 - 1) Resistência à rotura do aço: ver anexos, especialmente anexos C1, C2, C3, C4, C22, C24, C26
 - 2) Resistência à rotura combinada por arranque e cone de betão: ver anexos, especialmente anexos C5-C19, C27-C37
 - 3) Resistência à rotura por cone de betão: ver anexos, especialmente anexo C5, C27
 - 4) Distância ao bordo para prevenir rotura por fendilhação: ver anexos, especialmente anexo C5, C27
 - 5) Robustez: ver anexos, especialmente anexos C5-C19, C27-C37, C43-C45, C49, C50
 - 6) Torque de instalação máximo: ver anexos, especialmente anexos B4, B5, B9-B11, B14
 - 7) Distância mínima ao bordo e espaçamento, Espessura do substrato: ver anexos, especialmente anexos B4 - B14**Características de resistência ao corte (para acção estática e quase-estática):**
 - 8) Resistência à rotura do aço: ver anexos, especialmente anexos C1, C2, C3, C4, C23, C25, C26
 - 9) Resistência do betão ao destacamento: ver anexos, especialmente anexos C5, C27
 - 10) Resistência do bordo do betão: ver anexos, especialmente anexos C5, C27**Deslocamentos sob carregamento de curto e longo prazo:**
 - 11) Deslocamentos sob carregamento de curto e longo prazo: ver anexos, especialmente anexos C20, C21, C38, C39
 - 12) Resistência do betão armado com fibras de aço: ver anexos, especialmente anexo B3**Resistência característica e Deslocamentos para as categorias de performance sísmica C1 e C2:**
 - 13) Resistência à tração, categoria C1: ver anexos, especialmente anexos C40, C41, C43, C44, C46, C47, C49, C50
 - 14) Resistência à tração, categoria C2: ver anexos, especialmente anexos C41, C45
 - 15) Resistência ao corte, categoria C1: ver anexos, especialmente anexos C40, C41, C46, C47
 - 16) Resistência ao corte, categoria C2: ver anexos, especialmente anexos C41, C45**Segurança em caso de incêndio (BWR 2)**
 - 17) Reação ao fogo: Classe (A1)**Resistência ao fogo:**
 - 18) Resistência em caso de incêndio, rotura do aço (tração): ver anexos, especialmente anexos C51 - C53
 - 19) Resistência da ligação em condições de incêndio: ver anexos, especialmente anexo C54
 - 20) Resistência em caso de incêndio, rotura do aço (corte): ver anexos, especialmente anexos C51 - C53**Higiene, saúde e meio ambiente (BWR 3)**
 - 21) Conteúdo, emissão e / ou liberação de substâncias perigosas: NPD
8. Documentação Técnica Adequada e/ou Documentação Técnica Específica: **-**

O desempenho do produto identificado acima está em conformidade com o conjunto de desempenhos declarados. A presente declaração de desempenho é emitida, em conformidade com o Regulamento (UE) n.º 305/2011, sob a exclusiva responsabilidade do fabricante identificado acima.

Assinado por e em nome do fabricante por:



Alexander Zanocco, Diretor-Geral de Vendas e Diretor-Geral de Investigação & Desenvolvimento



Dieter Pfaff, Chefe da Federação Internacional de Produção e Gestão da Qualidade

Tumlingen, 2026-03-01

Este DoP foi preparado em diferentes línguas. Em caso de litígio sobre a interpretação, a versão em inglês prevalecerá sempre.

O Anexo inclui informações voluntárias e complementares em inglês que excedem os requisitos legais (linguisticamente especificados).

Translation guidance Essential Characteristics and Performance Parameters for Annexes

Guia de tradução das Características Essenciais e Parâmetros de Desempenho para os Anexos

Mechanical resistance and stability (BWR 1)		
Resistência mecânica e estabilidade (BWR 1)		
Characteristic resistance to tension load (static and quasi-static loading):		
Características de resistência à tração (para acção estática e quase-estática):		
1	Resistance to steel failure: Resistência à rotura do aço:	$N_{Rk,s}$ [kN]
2	Resistance to combined pull-out and concrete cone failure: Resistência à rotura combinada por arranque e cone de betão:	τ_{Rk} and/or $\tau_{Rk,100}$ [N/mm ²], $\psi_c, \psi_{sus}^0, \psi_{sus}, \psi_{sus,100}$ [-] (BF)
	Resistance to pull-out failure: Resistência à rotura por arranque:	$N_{Rk,p}$ and/or $N_{Rk,p,100}$ [kN], ψ_c [-] (BEF)
3	Resistance to concrete cone failure: Resistência à rotura por cone de betão:	$c_{cr,N}$ [mm], $k_{cr,N}$, $k_{ucr,N}$ [-]
4	Edge distance to prevent splitting under load: Distância ao bordo para prevenir rotura por fendilhação:	$c_{cr,sp}$ [mm]
5	Robustness: Robustez:	γ_{inst} [-]
6	Maximum installation torque: Torque de instalação máximo:	$\max T_{inst}$ [Nm] (BF)
	Installation torque: Torque de instalação:	T_{inst} [Nm] (BEF)
7	Minimum edge distance, spacing and member thickness: Distância mínima ao bordo e espaçamento, Espessura do substrato:	$c_{min}, s_{min}, h_{min}$ [mm]
Characteristic resistance to shear load (static and quasi-static loading):		
Características de resistência ao corte (para acção estática e quase-estática):		
8	Resistance to steel failure: Resistência à rotura do aço:	$V_{Rk,s}^0$ [kN], $M_{Rk,s}^0$ [Nm], k_7 [-]
9	Resistance to pry-out failure: Resistência do betão ao destacamento:	k_8 [-]
10	Resistance to concrete edge failure: Resistência do bordo do betão:	d_{nom}, l_f [mm]
Displacements under short-term and long-term loading:		
Deslocamentos sob carregamento de curto e longo prazo:		
11	Displacements factors under short-term and long-term loading: Deslocamentos sob carregamento de curto e longo prazo:	δ_0, δ_∞ [mm/(N/mm ²)] or [mm/kN]
12	Resistance in steel fibre reinforced concrete: Resistência do betão armado com fibras de aço:	Description
Characteristic resistance and displacements for seismic performance categories C1 and C2:		
Resistência característica e Deslocamentos para as categorias de performance sísmica C1 e C2:		
13	Resistance to tension for seismic performance category C1 Resistência à tração, categoria C1:	$N_{Rk,s,C1}$ [kN] (all) $\tau_{Rk,C1}$ [N/mm ²] (BF) $N_{Rk,p,C1}$ [kN] (BEF)
14	Resistance to tension and displacements for seismic performance category C2 Resistência à tração, categoria C2:	$N_{Rk,s,C2}$ [kN] (all) $\tau_{Rk,C2}$ [N/mm ²] (BF) $N_{Rk,p,C2}$ [kN] (BEF) $\delta_{N,C2(50\%)}, \delta_{N,C2(100\%)}$ [mm] (all)
15	Resistance to shear for seismic performance category C1 Resistência ao corte, categoria C1:	$V_{Rk,s,C1}$ [kN] (all)
16	Resistance to shear load and displacements for seismic performance category C2 Resistência ao corte, categoria C2:	$V_{Rk,s,C2}$ [kN] (all) $\delta_{V,C2(50\%)}, \delta_{V,C2(100\%)}$ [mm] (all)
Safety in case of fire (BWR 2)		
Segurança em caso de incêndio (BWR 2)		
17	Reaction to fire Reação ao fogo:	Class Classe (A1)
Resistance to fire		
Resistência ao fogo:		
18	Fire resistance to steel failure (tension load): Resistência em caso de incêndio, rotura do aço (tração):	$N_{Rk,s,fi}$ [kN]
19	Bond resistance under fire conditions: Resistência da ligação em condições de incêndio:	$k_{fi,p}(\theta)$ [-], $\tau_{Rk,fi}(\theta)$ [N/mm ²] (BF)
20	Fire resistance to steel failure under shear loading: Resistência em caso de incêndio, rotura do aço (corte):	$V_{Rk,s,fi}$ [kN], $M_{Rk,s,fi}^0$ [Nm]
Hygiene, health and the environment (BWR 3)		
Higiene, saúde e meio ambiente (BWR 3)		
21	Content, emission and/or release of dangerous substances: Conteúdo, emissão e / ou liberação de substâncias perigosas:	Description/Level

Specific Part

1 Technical description of the product

The "fischer injection system FIS EM Plus" is a bonded fastener consisting of a cartridge with injection mortar fischer FIS EM Plus and a steel element according to Annex A5.

The steel element is placed into a drilled hole filled with injection mortar and is anchored via the bond between metal part, injection mortar and concrete.

The product description is given in Annex A.

2 Specification of the intended use in accordance with the applicable European Assessment Document

The performances given in Section 3 are only valid if the anchor is used in compliance with the specifications and conditions given in Annex B.

The verifications and assessment methods on which this European Technical Assessment is based lead to the assumption of a working life of the anchor of at least 50 or 100 years. The indications given on the working life cannot be interpreted as a guarantee given by the producer, but are to be regarded only as a means for choosing the right products in relation to the expected economically reasonable working life of the works.

3 Performance of the product and references to the methods used for its assessment

3.1 Mechanical resistance and stability (BWR 1)

Essential characteristic	Performance
Characteristic resistance to tension load (static and quasi-static loading)	See Annex B4 to B15, C1 to C19, C22, C24, C26 to C37
Characteristic resistance to shear load (static and quasi-static loading)	See Annex C1 to C4, C23, C25, C26
Displacements under short-term and long-term loading	See Annex C20, C21, C38, C39
Characteristic resistance and displacements for seismic performance categories C1 and C2	See Annex C40 to C50

3.2 Safety in case of fire (BWR 2)

Essential characteristic	Performance
Reaction to fire	Class A1
Resistance to fire	See Annex C51 to C54

3.3 Hygiene, health and the environment (BWR 3)

Essential characteristic	Performance
Content, emission and/or release of dangerous substances	No performance assessed

4 Assessment and verification of constancy of performance (AVCP) system applied, with reference to its legal base

In accordance with the European Assessment Document EAD 330499-02-0601-v01 the applicable European legal act is: [96/582/EC].

The system to be applied is: 1

5 Technical details necessary for the implementation of the AVCP system, as provided for in the applicable European Assessment Document

Technical details necessary for the implementation of the AVCP system are laid down in the control plan deposited at Deutsches Institut für Bautechnik.

Installation conditions part 1

fischer Anchor rod FIS A / RG M (Anchor rod) and
commercial standard threaded rod (Threaded rod)

Pre-positioned installation

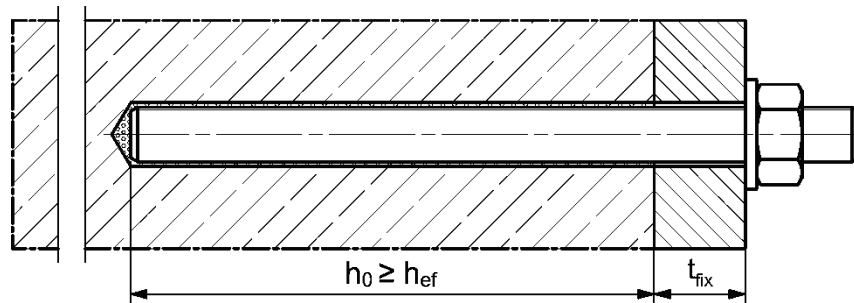

Push through installation (annular gap filled with mortar)

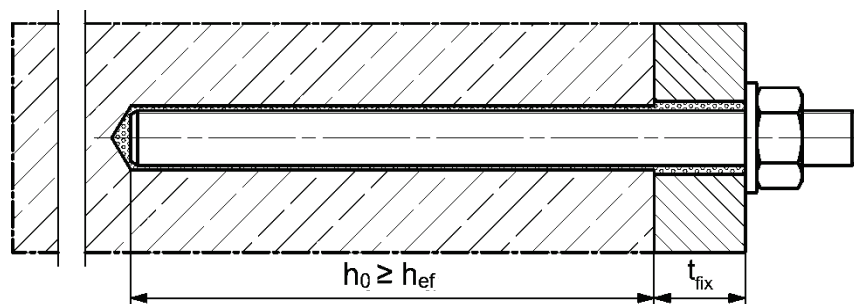

Pre-positioned or push through installation with subsequently injected fischer filling disc FFD (annular gap filled with mortar)

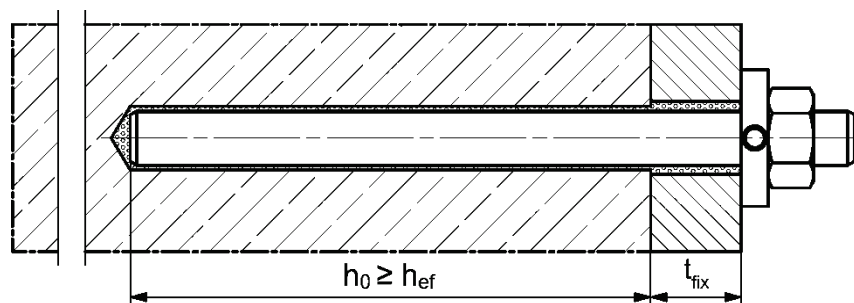

Figures not to scale

h_0 = drill hole depth

h_{ef} = effective embedment depth

t_{fix} = thickness of fixture

fischer Injection System FIS EM PLUS

Product description
Installation conditions part 1

Annex A1
Appendix 3 / 28

Installation conditions part 2

fischer internal threaded anchor RG M I (fischer RG M I)

Pre-positioned installation

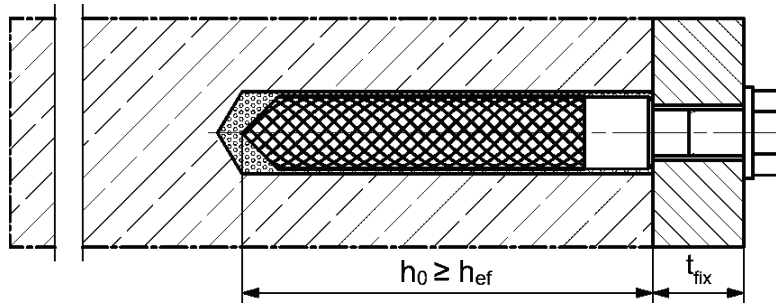

fischer internal threaded anchor FIS IG (fischer FIS IG)

Pre-positioned installation

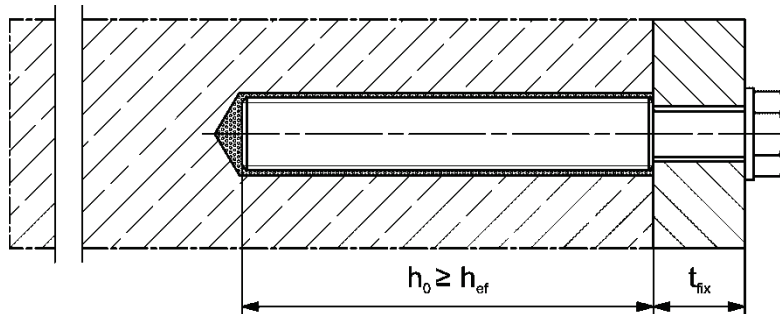

Pre-positioned installation with subsequently injected fischer filling disc (annular gap filled with mortar)

Can be used in conjunction with fischer RG M I and fischer FIS IG.

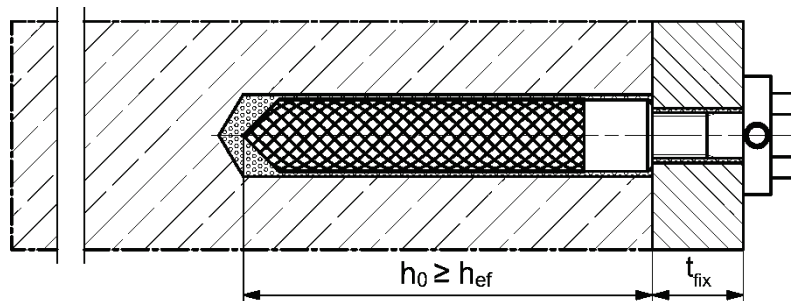

Figures not to scale

h_0 = drill hole depth

h_{ef} = effective embedment depth

t_{fix} = thickness of fixture

fischer Injection System FIS EM PLUS

Product description
Installation conditions part 2

Annex A2
Appendix 4 / 28

Installation conditions part 3

Reinforcing bar (Rebar)

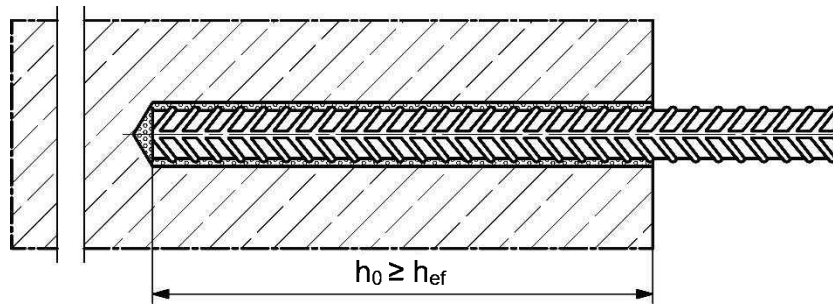

fischer rebar anchor FRA (fischer FRA)

Pre-positioned installation

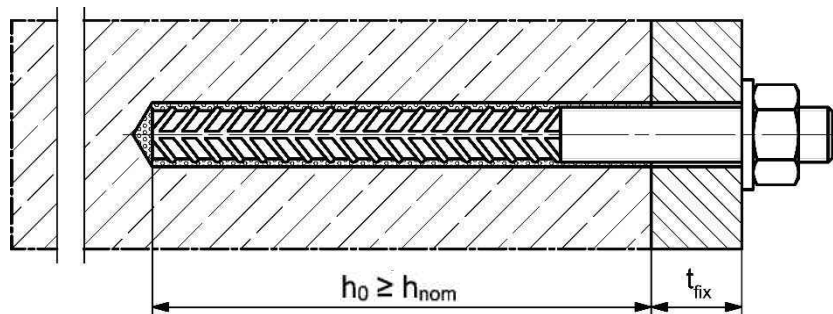

Push through installation (annular gap filled with mortar)

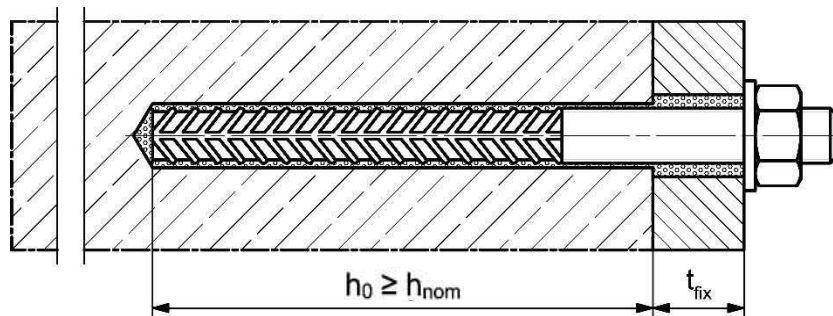

Figures not to scale

h_0 = drill hole depth

h_{ef} = effective embedment depth

t_{fix} = thickness of fixture

h_{nom} = overall fastener embedment depth in the concrete

fischer Injection System FIS EM PLUS

Product description
Installation conditions part 3

Annex A3
Appendix 5 / 28

Overview system components part 1

Injection cartridge (shuttle cartridge) FIS EM Plus with sealing cap

Sizes: 390 ml, 585 ml, 1500 ml (the 390 ml hard cartridge is shown as an example)

Size foil bag: 500 ml

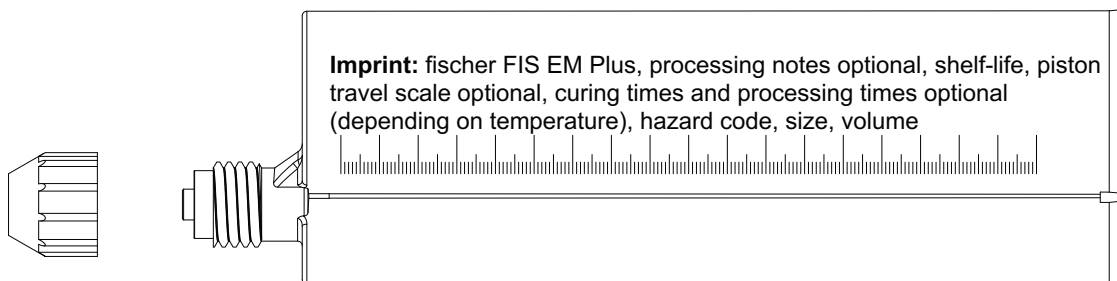

Injection cartridge (coaxial cartridge) FIS EM Plus with sealing cap

Sizes: 300 ml

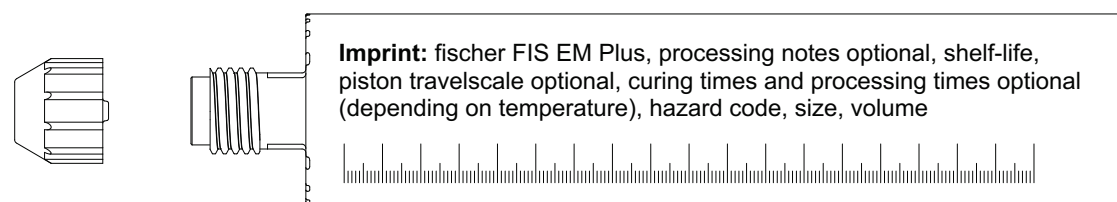

Static mixer FIS MR Plus for injection cartridges ≤ 500 ml

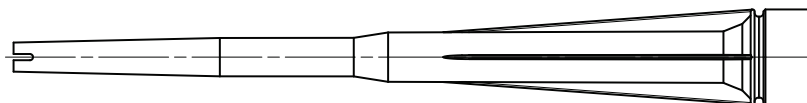

Static mixer FIS UMR for injection cartridges ≥ 500 ml

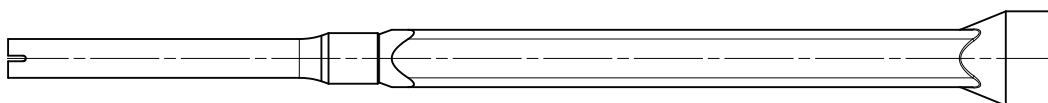

Injection adapter and extension tube $\varnothing 9$ for static mixer FIS MR Plus; Injection adapter and extension tube $\varnothing 9$ or $\varnothing 15$ for static mixer FIS UMR

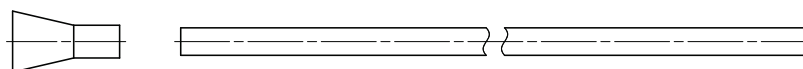

Cleaning brush BS / BSB



Compressed-air cleaning tool ABP



Figures not to scale

fischer Injection System FIS EM PLUS

Product description

Overview system components part 1;
cartridges / static mixer / accessories

Annex A4

Appendix 6 / 28

Overview system components part 2

Anchor rod / Threaded rod

Metric size: M8, M10, M12, M14, M16, M20, M22, M24, M27, M30
 Fractional size: 3/8", 1/2", 5/8", 3/4", 7/8", 1", 1 1/8"

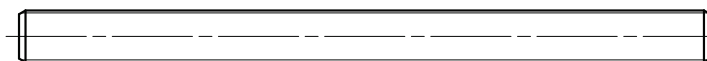

fischer RG M I

Metric size: M8, M10, M12, M16, M20
 Fractional size: 3/8", 1/2", 5/8", 3/4"



fischer FIS IG

Metric size: M8, M10, M12, M16, M20



Screw / Anchor rod / Threaded rod / washer / hexagon nut

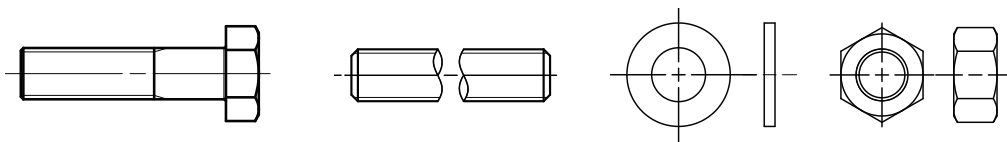

fischer filling disc FFD with injection adapter

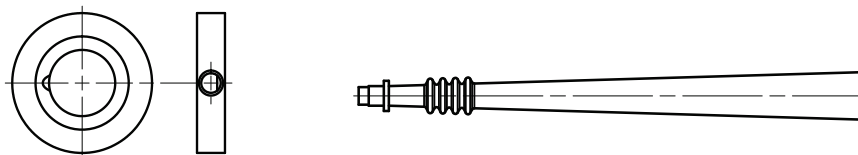

fischer centering clip DD-S / DD-E



Reinforcing bar

Nominal diameter,
 Metric size: $\phi 8$, $\phi 10$, $\phi 12$, $\phi 14$, $\phi 16$, $\phi 18$, $\phi 20$, $\phi 22$, $\phi 24$, $\phi 25$, $\phi 26$, $\phi 28$, $\phi 30$, $\phi 32$, $\phi 34$, $\phi 36$, $\phi 40$
 Fractional size: #3 (3/8"), #4 (1/2"), #5 (5/8"), #6 (3/4"), #7 (7/8"), #8 (1"), #9 (1,128"), #10 (1,270")



fischer FRA

Metric size: M12, M16, M20, M24



Figures not to scale

fischer Injection System FIS EM PLUS

Product description
 Overview system components part 2;
 steel components

Annex A5
 Appendix 7 / 28

Table A6.1: Materials, metric sizes

Part	Designation	Material		
1	Injection cartridge	Mortar, hardener, filler		
	Steel grade	Steel zinc plated (zp, hdg)	Stainless steel R acc. to EN 10088-1:2023 Corrosion resistance class CRC III acc. to EN 1993-1-4:2006+A1:2015	High corrosion resistant steel HCR acc. to EN 10088-1:2023 Corrosion resistance class CRC V acc. to EN 1993-1-4:2006+A1:2015
2	Anchor rod / Threaded rod	Property class 4.8, 5.8 or 8.8; EN ISO 898-1:2013 zp ≥ 5 µm, EN ISO 4042:2022 or hot dip galvanised ≥ 40 µm EN ISO 10684:2004+AC:2009 $f_{uk} \leq 1000 \text{ N/mm}^2$ $A_5 > 12 \%$ fracture elongation ¹⁾	Property class 50, 70 or 80; EN ISO 3506-1:2020 1.4401; 1.4404; 1.4578; 1.4571; 1.4439; 1.4362; 1.4062; 1.4662; 1.4462; EN 10088-1:2023 $f_{uk} \leq 1000 \text{ N/mm}^2$ $A_5 > 12 \%$ fracture elongation ¹⁾	Property class 50, 70 or 80; EN ISO 3506-1:2020 or property class HCR 70 with $f_{yk} = 560 \text{ N/mm}^2$; 1.4565; 1.4529; EN 10088-1:2023 $f_{uk} \leq 1000 \text{ N/mm}^2$ $A_5 > 12 \%$ fracture elongation ¹⁾
3	Washer ISO 7089:2000	zinc plated ≥ 5 µm, EN ISO 4042:2022 or hot dip galvanised ≥ 40 µm EN ISO 10684:2004+AC:2009	1.4401; 1.4404; 1.4578; 1.4571; 1.4439; 1.4362; EN 10088-1:2023	1.4565; 1.4529; EN 10088-1:2023
4	Hexagon nut	Property class 5 or 8 acc. EN ISO 898-2:2022 zinc plated ≥ 5 µm, EN ISO 4042:2022 or hot dip galvanised ≥ 40 µm EN ISO 10684:2004+AC:2009	Property class 50, 70 or 80 acc. EN ISO 3506-2:2020 1.4401; 1.4404; 1.4578; 1.4571; 1.4439; 1.4362; EN 10088-1:2023	Property class 50, 70 or 80 acc. EN ISO 3506-2:2020 1.4565; 1.4529; EN 10088-1:2023
5	fischer RG M I / fischer FIS IG	Property class 5.8 EN ISO 898-1:2013 zinc plated ≥ 5 µm, EN ISO 4042:2022	Property class 70 EN ISO 3506-1:2020; 1.4401; 1.4404; 1.4578; 1.4571; 1.4439; 1.4362; EN 10088-1:2023	Property class 70 EN ISO 3506-1:2020 1.4565; 1.4529; EN 10088-1:2023
6	Commercial standard screw or Anchor rod / Threaded rod for fischer RG M I / fischer FIS IG	Property class 5.8 or 8.8; EN ISO 898-1:2013 zinc plated ≥ 5 µm, EN ISO 4042:2022 $A_5 > 8 \%$ fracture elongation	Property class 70 EN ISO 3506-1:2020 1.4401; 1.4404; 1.4578; 1.4571; 1.4439; 1.4362; EN 10088-1:2023 $A_5 > 8 \%$ fracture elongation	Property class 70 EN ISO 3506-1:2020 1.4565; 1.4529; EN 10088-1:2023 $A_5 > 8 \%$ fracture elongation
7	fischer filling disc similar to DIN 6319-G	zinc plated ≥ 5 µm, EN ISO 4042:2022 or hot dip galvanised ≥ 40 µm EN ISO 10684:2004+AC:2009	1.4401; 1.4404; 1.4578; 1.4571; 1.4439; 1.4362; EN 10088-1:2023	1.4565; 1.4529; EN 10088-1:2023
8	Rebar	EN 1992-1-1:2004 and AC:2010, Annex C Bars and de-coiled rods, class B or C with f_{yk} and k according to NDP or NCI according to EN 1992-1-1/NA; $f_{uk} = f_{tk} = k \cdot f_{yk}$ ($A_5 > 12 \%$) ¹⁾		
9	fischer FRA	Rebar part: Bars and de-coiled rods class B or C with f_{yk} and k according to NDP or NCI of EN 1992-1-1:2004+AC:2010 $f_{uk} = f_{tk} = k \cdot f_{yk}$ ($A_5 > 8 \%$) Threaded part: Property class 80 EN ISO 3506-1:2020	1.4401, 1.4404, 1.4571, 1.4578, 1.4439, 1.4362, 1.4062 acc. to EN 10088-1:2023 Corrosion resistance class CRC III acc. to EN 1993-1-4:2006+A1:2015 1.4565; 1.4529 acc. to EN 10088-1:2023 Corrosion resistance class CRC V acc. to EN 1993-1-4:2006+A1:2015 $f_{uk} \leq 1000 \text{ N/mm}^2$; fracture elongation $A_5 > 8 \%$	

¹⁾ Fracture elongation $A_5 > 8 \%$, for applications without requirements for seismic performance category C1 or C2.

fischer Injection System FIS EM PLUS

Product description
Materials, metric sizes

Annex A6
Appendix 8 / 28

Table A7.1: Materials, fractional sizes

Part	Designation	Material	
1	Injection cartridge	Mortar, hardener, filler	
	Steel grade	Steel zinc plated (zp, hdg)	Stainless steel R Corrosion resistance class CRC III acc. to EN 1993-1-4:2006+A1:2015
2	Fractional Threaded rod	ASTM F568M-07, Class 5.8 $f_{uk} = 500 \text{ N/mm}^2$, $A_5 > 12 \%$ fracture elongation ¹⁾ ; zinc plated $\geq 5 \mu\text{m}$, EN ISO 4042:2022 ASTM F1554-20, Grade 36 $f_{uk} = 400 \text{ N/mm}^2$, $A_5 > 12 \%$ fracture elongation ¹⁾ ; zinc plated $\geq 5 \mu\text{m}$, EN ISO 4042:2022 ASTM F1554-20, Grade 55 $f_{uk} = 517 \text{ N/mm}^2$, $A_5 > 12 \%$ fracture elongation ¹⁾ ; zinc plated $\geq 5 \mu\text{m}$; EN ISO 4042:2022 ASTM F1554-20, Grade 105 $f_{uk} = 862 \text{ N/mm}^2$, $A_5 > 12 \%$ fracture elongation ¹⁾ ; zinc plated $\geq 5 \mu\text{m}$, EN ISO 4042:2022 ASTM A193/A193M-23, Grade B7 $f_{uk} = 862 \text{ N/mm}^2$, $A_5 > 12 \%$ fracture elongation ¹⁾ ; zinc plated $\geq 5 \mu\text{m}$, EN ISO 4042:2022	ASTM F593M-13ae1, Alloy Group 2 $f_{uk} = 689 \text{ N/mm}^2$, $f_{uk} \leq 5/8 \text{ in. (CW1)}$ $f_{uk} = 586 \text{ N/mm}^2$, $f_{uk} \geq 3/4 \text{ in. (CW2)}$ $A_5 > 12 \%$ fracture elongation ¹⁾ ; ASTM A193/A193M-23, Grade B8M, Class 1 $f_{uk} = 517 \text{ N/mm}^2$, $A_5 > 12 \%$ fracture elongation ¹⁾ ; ASTM A193/A193M-23, Grade B8M, Class 2B $f_{uk} = 655 \text{ N/mm}^2$, $A_5 > 12 \%$ fracture elongation ¹⁾
3	Washer	ASTM F436/F436M-19 zinc plated $\geq 5 \mu\text{m}$, EN ISO 4042:2022 or hot dip galvanised $\geq 40 \mu\text{m}$ EN ISO 10684:2004+AC:2009	ASTM A240/A240M-23a Type 316
4	Hexagon nut	ASTM A563/A563M-23, Grade DH or ASTM A194/A194M-23, Grade 2H for Threaded rod material ASTM F568M-07, Class 5.8 or ASTM F1554-20, Grade 36, 55, 105 ASTM A194/A194M-23, Grade 2H / 4 / 7 for Threaded rod material ASTM A193/A193M-23, B7 zinc plated $\geq 5 \mu\text{m}$, EN ISO 4042:2022	ASTM F593M-13ae1, Alloy Group 2 for Threaded rod material: ASTM F593M-13ae1, Alloy Group 2 / ASTM A193/A193M-23, Grade 8M for Threaded rod material: ASTM A193/A193M-23, Grade B8M, Class 1 or ASTM A193/A193M-23, Grade B8M, Class 2B
5	fischer RG M I	Property class 5.8 EN ISO 898-1:2013 zinc plated $\geq 5 \mu\text{m}$, ISO 4042:2022	Property class 70; EN ISO 3506-1:2020; 1.4401; 1.4404; 1.4578; 1.4571; 1.4439; 1.4362; EN 10088-1:2023
6	Commercial standard screw or Threaded rod for fischer RG M I	See Table A7.1, line 2, steel zinc plated, EN ISO 4042:2022	See Table A7.1, line 2, stainless steel R
7	fischer filling disc similar to DIN 6319-G	zinc plated $\geq 5 \mu\text{m}$, EN ISO 4042:2022 or hot dip galvanised $\geq 40 \mu\text{m}$ EN ISO 10684:2004+AC:2009	1.4401; 1.4404; 1.4578; 1.4571; 1.4439; 1.4362; EN 10088-1:2023
8	Reinforcing bar	ASTM A615/A615M-22 (ASTM A767/A767M-19) Grade 40, $f_{uk} = 414 \text{ N/mm}^2$, $f_{yk} = 276 \text{ N/mm}^2$, $A_5 > 12 \%$ fracture elongation ¹⁾ Grade 60, $f_{uk} = 621 \text{ N/mm}^2$, $f_{yk} = 414 \text{ N/mm}^2$, $A_5 > 12 \%$ fracture elongation ¹⁾ Grade 75, $f_{uk} = 689 \text{ N/mm}^2$, $f_{yk} = 517 \text{ N/mm}^2$, $A_5 > 12 \%$ fracture elongation ¹⁾ Grade 60, $f_{uk} = 552 \text{ N/mm}^2$, $f_{yk} = 414 \text{ N/mm}^2$, $A_5 > 12 \%$ fracture elongation ¹⁾ Grade 80, $f_{uk} = 689 \text{ N/mm}^2$, $f_{yk} = 552 \text{ N/mm}^2$, $A_5 > 12 \%$ fracture elongation ¹⁾	

¹⁾ Fracture elongation $A_5 > 8 \%$, for applications without requirements for seismic performance category C1 or C2.









fischer Injection System FIS EM PLUS

Product description
Materials, fractional sizes

Annex A7
Appendix 9 / 28

Specifications of intended use part 1

Table B1.1: Overview use categories

Anchorages subject to		FIS EM Plus with ...				
		Anchor rod / Threaded rod 	fischer RG M I 	fischer FIS IG 	Reinforcing bar 	fischer FRA 
Hammer drilling with standard drill bit 		all sizes				
Hammer drilling with hollow drill bit 		Nominal drill bit diameter (d_0) 12 mm to 35 mm; 7/16" to 1 3/8" (fischer "FHD", Heller "Duster Expert"; Bosch „Speed Clean“; Hilti "TE-CD, TE-YD", DreBo „D-Plus“, DreBo „D-Max“)				
Diamond drilling 		all sizes				
Use category	I1 dry or wet concrete	all sizes				
	I2 water filled hole	all sizes (not permitted for diamond drilling in combination with cracked concrete and working life 100 years)				
Installation direction		D3 (downward and horizontal and upwards (e.g. overhead) installation)				
Installation temperature		$T_{i,min} = -5\text{ °C}$ to $T_{i,max} = +40\text{ °C}$ for the standard variation of temperature after installation				
In-service temperature	Temperature range I	-40 °C to +40 °C	(max. short term temperature +40 °C; max. long term temperature +24 °C)			
	Temperature range II	-40 °C to +60 °C	(max. short term temperature +60 °C; max. long term temperature +35 °C)			
	Temperature range III	-40 °C to +72 °C	(max. short term temperature +72 °C; max. long term temperature +50 °C)			





fischer Injection System FIS EM PLUS

Intended use
Specifications part 1

Annex B1
Appendix 10 / 28

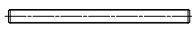
Specifications of intended use part 2

Table B2.1: Overview performance categories and annexes

		FIS EM Plus with ...									
		Anchor rod / Threaded rod	fischer RG M I	fischer FIS IG	Reinforcing bar	fischer FRA					
											
Performance category		Annexes									
Static and quasi static load, in uncracked / cracked concrete with or without steel fibres	Metric sizes	M8 to M30	C1, C5, C6, C7, C20	M8 to M20	C2, C5, C8, C9, C20	M8 to M20	C3, C5, C10, C11, C20	φ8 to φ40	C4, C5, C9, C12, C13, C14, C15, C16, C21	M12 to M24	C4, C5, C17, C18, C19, C21
	Fractional sizes	3/8" to 1 1/8"	C22, C23, C27, C28, C29, C30, C31, C38	3/8" to 3/4"	C24, C25, C27, C32, C33, C34, C38	-1)	-1)	#3 to #10	C26, C27, C35, C36, C37, C39	-1)	-1)
Seismic performance category in concrete with or without steel fibres	C1	M10 to M30	C40, C41, C42, C43, C45	-1)	-1)	-1)	-1)	φ10 to φ32	C41, C42, C41, C44	-1)	-1)
		3/8" to 1 1/8"	C46, C48, C49					#3 to #10	C47, C48, C50		
(only hammer drilling with standard / hollow drill bits)	C2	M12 M16 M20 M24	C41 C42 C45	-1)	-1)	-1)	-1)	-1)	-1)	-1)	-1)
Resistance to fire in concrete with or without steel fibres (only hammer drilling with standard / hollow drill bits)			C51, C52, C53, C54	-1)	-1)	-1)	-1)	-1)	-1)	-1)	-1)

¹⁾ no performance assessed.

fischer Injection System FIS EM PLUS

Intended use
Specifications part 2

Annex B2
Appendix 11 / 28

Specifications of intended use part 3

Base materials:

- Compacted reinforced or unreinforced normal weight concrete of strength classes C20/25 to C50/60 according to EN 206:2013+A2:2021.
- Steel fibre reinforced concrete according to EN 206:2013+A2:2021 with steel fibers in accordance to EN 14889-1:2006, clause 5, group I, with a maximum fibre content of 80 kg/m³.

Use conditions (Environmental conditions):

- Fastener intended for use in structures subject to dry, internal conditions (all materials).
- For all other conditions according to EN 1993-1-4:2006+A1:2015 corresponding to corrosion resistance classes to Annex A6 table A6.1 (metric sizes) or Annex A7 table A7.1 (fractional sizes).

Design:

- Fastenings are designed in accordance with: EN 1992-4:2018 and TR 082 from June 2023.
- Fastenings in steel fibre reinforced concrete can be designed according to EN 1992-4:2018. The performance for normal weight concrete of strength classes C20/25 to C50/60 without fibres applies.
- The structural design is conducted under responsibility of a designer experienced in the field of anchorages and concrete works.
- Verifiable calculation notes and drawings are to be prepared taking account of the loads to be anchored. The position of the fastener is indicated on the design drawings (e. g. position of the fastener relative to reinforcement or to supports, etc.).

Installation:

- Fastener installation is to be carried out by appropriately qualified personnel and under the supervision of the person responsible for technical matters of the site.
- Fastening depth should be marked and adhered to installation.
- Overhead installation is allowed (necessary equipment see installation instruction).

fischer Injection System FIS EM PLUS

Intended use
Specifications part 3

Annex B3
Appendix 12 / 28

Table B4.1: Installation parameters for metric Anchor rods / Threaded rods

Anchor rods / Threaded rods		M8	M10	M12	M14	M16	M20	M22	M24	M27	M30
Nominal drill hole diameter	d_0	10	12	14	16	18	22 ¹⁾ 24	25	28	30	35
Drill hole depth	h_0 ²⁾	$h_0 \geq h_{ef}$									
Effective embedment depth	$h_{ef, min}$	40	40	48	56	64	80	88	96	108	120
Minimum spacing	s_{min}	160	200	240	280	320	400	440	480	540	600
Minimum edge distance	c_{min}	according to Annex B6									
Diameter of the pre-positioned installation	d_f	9	12	14	16	18	22	24	26	30	33
Diameter of the clearance hole of the fixture	d_f	12	14	16	18	20	26	28	30	33	40
Minimum thickness of concrete member	h_{min} ²⁾	$h_{ef} + 30 (\geq 80)$			$h_{ef} + 2d_0$						
Maximum installation torque	$max T_{inst}$ [Nm]	10	20	40	50	60	120	135	150	200	300

¹⁾ Alternative drill hole diameter $d_0 = 22$ mm permissible (does not apply when using centering clips DD-S / DD-E).

²⁾ When using centering clips DD-S / DD-E, observe the deviating specifications according to Table B15.3.

Anchor rod / Threaded rod

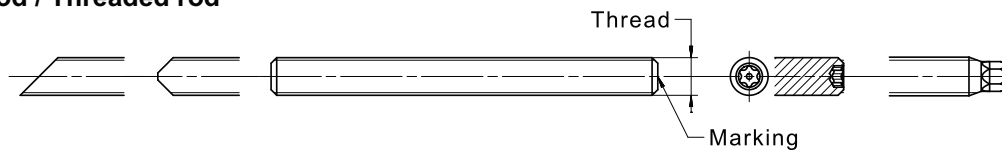

Marking (on random place) anchor rod:

Steel zinc plated PC ¹⁾ 8.8	• or +	Steel hot-dip PC ¹⁾ 8.8	•
High corrosion resistant steel HCR PC ¹⁾ 50	•	High corrosion resistant steel HCR PC ¹⁾ 70	-
High corrosion resistant steel HCR PC ¹⁾ 80	(Stainless steel R PC ¹⁾ 70	~
Stainless steel R PC ¹⁾ 80	*		

Alternatively: Colour coding according to DIN 976-1:2016

¹⁾ PC = property class

Installation conditions:

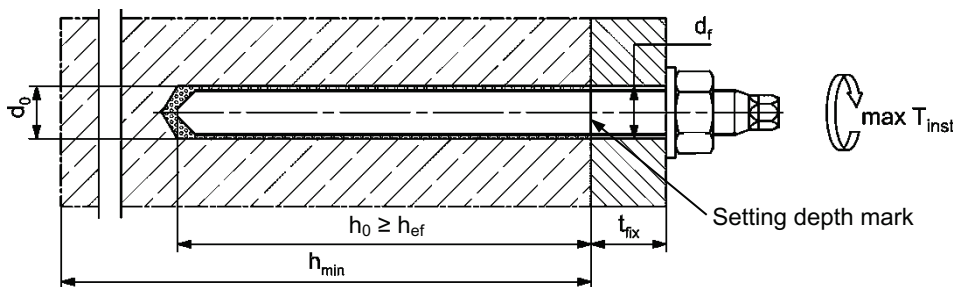

Threaded rods, washers and hexagon nuts may also be used if the following requirements are fulfilled:

- Materials, dimensions and mechanical properties according to Annex A6, Table A6.1.
- Inspection certificate 3.1 according to EN 10204:2004, the documents shall be stored.
- Setting depth is marked.
- Steel load-bearing capacities for hot-dip galvanised parts are only valid if the threaded rod and nut are correctly paired. The strength class of the nut must be one strength class higher than that of the threaded rod ($\geq M12$ in combination with tolerance class 6AX in accordance with EN ISO 10684:2004+AC:2009 two strength classes higher). The pairing of undersized threaded rods (additional designation U according to EN ISO 10684) with oversized nuts (additional designation Z or X according to EN ISO 10684) is not permitted under any circumstances.

Figures not to scale

fischer Injection System FIS EM PLUS

Intended use

Installation parameters Anchor rods / Threaded rods (metric size)

Annex B4

Appendix 13 / 28

Table B5.1: Installation parameters for fractional Threaded rods

Threaded rods			3/8"	1/2"	5/8"	3/4"	7/8"	1"	1 1/8"
Nominal drill hole diameter	d_0	[mm]	11,1	14,3	19,1	22,2	25,4	28,6	31,8
		[inch]	7/16	9/16	3/4	7/8	1	1 1/8	1 1/4
Drill hole depth	h_0		$h_0 \geq h_{ef}$						
Effective embedment depth	$h_{ef, min}$		40,0	51,0	64,0	76,5	89,0	102,0	178,0
	$h_{ef, max}$		191,0	254,0	318,0	381,0	445,0	508,0	572,0
Minimum spacing	s_{min}		according to Annex B7						
Minimum edge distance	c_{min}		according to Annex B7						
Diameter of the clearance hole of the fixture	pre-positioned installation	d_f	8,9	11,9	14,0	16,0	18,0	22,1	23,9
	push through installation	d_f	11,9	14,0	16,0	18,0	20,1	25,9	27,9
Minimum thickness of concrete member	h_{min}		$h_{ef} + 30 (\geq 80)$		$h_{ef} + 2d_0$				
Maximum installation torque	$\max T_{inst}$	[Nm]	18	41	60	107	136	173	180

1) Both drill hole diameters can be used.

Threaded rods

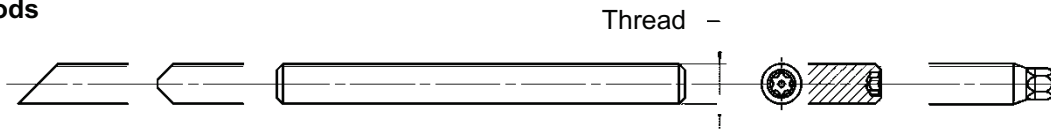

Installation conditions:

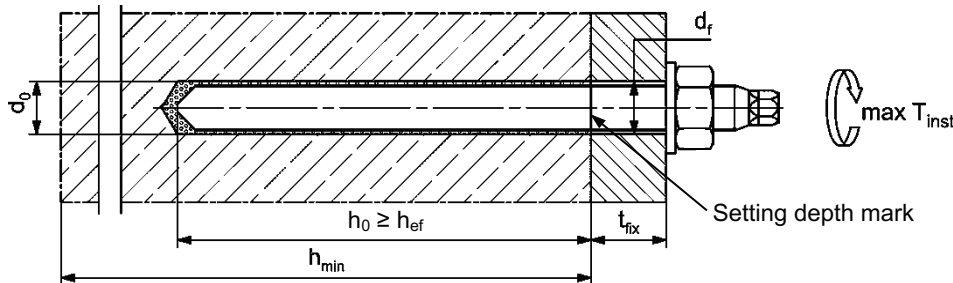

Additional requirements for Threaded rods, washers and hexagon nuts:

- Materials, dimensions and mechanical properties according to **Annex A7, Table A7.1**.
- Inspection certificate 3.1 according to EN 10204:2004, the documents shall be stored.
- Setting depth is marked.
- Steel load-bearing capacities for hot-dip galvanised parts are only valid if the threaded rod and nut are correctly paired. The strength class of the nut must be one strength class higher than that of the threaded rod ($\geq M12$ in combination with tolerance class 6AX in accordance with EN ISO 10684:2004+AC:2009 two strength classes higher). The pairing of undersized threaded rods (additional designation U according to EN ISO 10684) with oversized nuts (additional designation Z or X according to EN ISO 10684) is not permitted under any circumstances.

Figures not to scale

fischer Injection System FIS EM PLUS

Intended use
Installation parameters Threaded rods (fractional size)

Annex B5
Appendix 14 / 28

Table B6.1: Minimum spacing and minimum edge distance for metric Anchor rods / Threaded rods, metric fischer FIS IG and metric reinforcing bars

Metric Anchor rods		M8	M10	-	M12	M14	-	M16	-	-	M20	M22	-	
Metric fischer FIS IG		-	-	M8	-	-	M10	-	-	M12	-	-	M16	
Metric Reinforcing bars (nominal diameter)	ϕ	8	10	-	12	14	-	16	18	-	20	22	-	
Minimum edge distance														
Uncracked / cracked concrete	c_{min}	[mm]	40	45	45	45	45	50	50	55	55	55	55	60
Minimum spacing	s_{min}		according to Annex B8											
Minimum spacing														
Uncracked / cracked concrete	s_{min}	[mm]	40	45	55	55	60	65	65	85	85	85	95	105
Minimum edge distance	c_{min}		according to Annex B8											
Required projecting area														
Uncracked concrete	$A_{sp,req}$	[1000 mm ²]	8,0	13,0	5,5	21,5	23,0	8,0	24,0	38,5	13,0	38,5	39,5	21,5
Cracked concrete		mm ²	6,5	10,0	4,5	16,5	17,5	6,5	18,5	29,5	10,0	29,5	30,0	16,5

Metric Anchor rods		M24	-	-	M27	-	-	M30	-	-	-	-	-
Metric fischer FIS IG		-	-	-	-	-	M20	-	-	-	-	-	-
Metric Reinforcing bars (nominal diameter)	ϕ	24	25	26	-	28	-	30	32	34	36	40	
Minimum edge distance													
Uncracked / cracked concrete	c_{min}	[mm]	60	75	75	75	80	80	80	120	120	135	175
Minimum spacing	s_{min}		according to Annex B8										
Minimum spacing													
Uncracked / cracked concrete	s_{min}	[mm]	105	120	120	120	140	140	140	160	160	160	160
Minimum edge distance	c_{min}		according to Annex B8										
Required projecting area													
Uncracked concrete	$A_{sp,req}$	[1000 mm ²]	40,0	47,5	47,5	47,5	64,0	26,0	64,0	64,0	64,0	64,0	64,0
Cracked concrete		mm ²	30,5	36,5	36,5	36,5	49,0	20,0	49,0	49,0	49,0	49,0	49,0

Splitting failure for minimum edge distance and spacing in dependence of the effective embedment depth h_{ef} .

For the calculation of minimum spacing and minimum edge distance of anchors in combination with different embedment depths and thicknesses of concrete members the following equation shall be fulfilled:

$$A_{sp,req} < A_{sp,t}$$

$A_{sp,req}$ = required projecting area,
 $A_{sp,t}$ = projecting area (according to **Annex B8**).

fischer Injection System FIS EM PLUS

Intended use

Minimum spacing and edge distance for Anchor rods / Threaded rods, fischer FIS IG and reinforcing bars

Annex B6

Appendix 15 / 28

Table B7.1: Minimum spacing and minimum edge distance for fractional Threaded rods and reinforcing bars

Fractional Threaded rods		3/8"	1/2"	5/8"	3/4"	7/8"	1"	1 1/8"	-	
Fractional Reinforcing bars		#3	#4	#5	#6	#7	#8	#9	#10	
Minimum edge distance										
Uncracked / cracked concrete	c_{min}	[mm]	45	45	50	55	60	75	80	120
Minimum spacing	s_{min}		according to Annex B8							
Minimum spacing										
Uncracked / cracked concrete	s_{min}	[mm]	45	60	65	85	105	120	140	160
Minimum edge distance	c_{min}		according to Annex B8							
Required projecting area										
Uncracked concrete	$A_{sp,req}$	[1000	12,5	21,0	24,5	36,0	39,5	43,5	40,5	64,5
Cracked concrete		mm ²]	9,5	16,0	18,5	27,5	30,0	33,5	31,0	49,5

Splitting failure for minimum edge distance and spacing in dependence of the effective embedment depth h_{ef} .

For the calculation of minimum spacing and minimum edge distance of anchors in combination with different embedment depths and thicknesses of concrete members the following equation shall be fulfilled:

$$A_{sp,req} < A_{sp,t}$$

$A_{sp,req}$ = required projecting area,
 $A_{sp,t}$ = projecting area (according to **Annex B8**).

fischer Injection System FIS EM PLUS

Intended use
 Minimum spacing and edge distance for Threaded rods and reinforcing bars

Annex B7
 Appendix 16 / 28

Table B8.1: Projecting area $A_{sp,t}$ with concrete member thickness
 $h > h_{ef} + 1,5 \cdot c$ and $h \geq h_{min}$

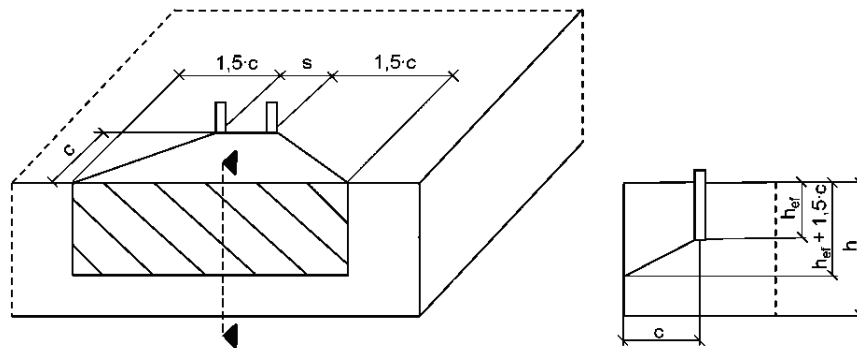

Single fastener		$A_{sp,t} = (3 \cdot c) \cdot (h_{ef} + 1,5 \cdot c)$	[mm ²]	with $c \geq c_{min}$
Group of fastener with	$s > 3 \cdot c$	$A_{sp,t} = (6 \cdot c) \cdot (h_{ef} + 1,5 \cdot c)$	[mm ²]	
Group of fastener with	$s \leq 3 \cdot c$	$A_{sp,t} = (3 \cdot c + s) \cdot (h_{ef} + 1,5 \cdot c)$	[mm ²]	

Table B8.2: Projecting area $A_{sp,t}$ with concrete member thickness
 $h \leq h_{ef} + 1,5 \cdot c$ and $h \geq h_{min}$

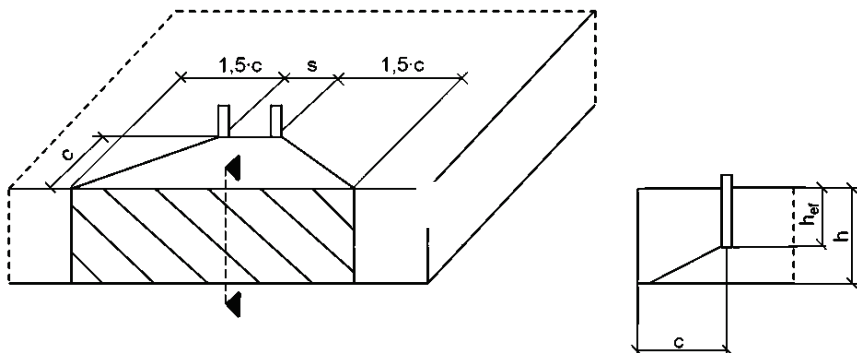

Single anchor		$A_{sp,t} = 3 \cdot c \cdot \text{existing } h$	[mm ²]	with $c \geq c_{min}$
Group of fastener with	$s > 3 \cdot c$	$A_{sp,t} = 6 \cdot c \cdot \text{existing } h$	[mm ²]	
Group of fastener with	$s \leq 3 \cdot c$	$A_{sp,t} = (3 \cdot c + s) \cdot \text{existing } h$	[mm ²]	

Edge distance and axial spacing shall be rounded up to at least 5 mm.

Figures not to scale

fischer Injection System FIS EM PLUS

Intended use

Minimum thickness of concrete member for Anchor rods / Threaded rods, fischer FIS IG and reinforcing bars; minimum spacing and edge distance

Annex B8

Appendix 17 / 28

Table B9.1: Installation parameters for metric fischer RG M I

fischer RG M I		Thread	M8	M10	M12	M16	M20
Diameter of anchor	$d_{nom} = d_H$	[mm]	12	15,7	18	22	28
Nominal drill hole diameter	d_0		14	18	20	24	32
Drill hole depth	h_0		$h_0 \geq h_{ef} = L_H$				
Effective embedment depth ($h_{ef} = L_H$)	h_{ef}		90	90	125	160	200
Minimum spacing and minimum edge distance	$S_{min} = C_{min}$		55	65	75	95	125
Diameter of clearance hole in the fixture	d_f		9	12	14	18	22
Minimum thickness of concrete member	h_{min}		120	125	165	205	260
Maximum screw-in depth	$l_{E,max}$		18	23	26	35	45
Minimum screw-in depth	$l_{E,min}$	8	10	12	16	20	
Maximum installation torque	$\max T_{inst}$	[Nm]	10	20	40	80	120

fischer RG M I

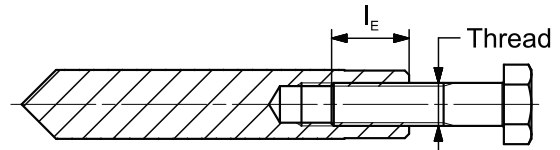
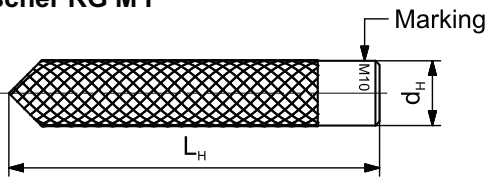

Marking: Anchor size e. g.: **M10**
 Stainless steel → additional **R**; e.g.: **M10 R**
 High corrosion resistant steel → additional **HCR**; e.g.: **M10 HCR**

Retaining screw or threaded rods (including nut and washer) must comply with the appropriate material and strength class of **Annex A6, Table A6.1**.

Installation conditions:

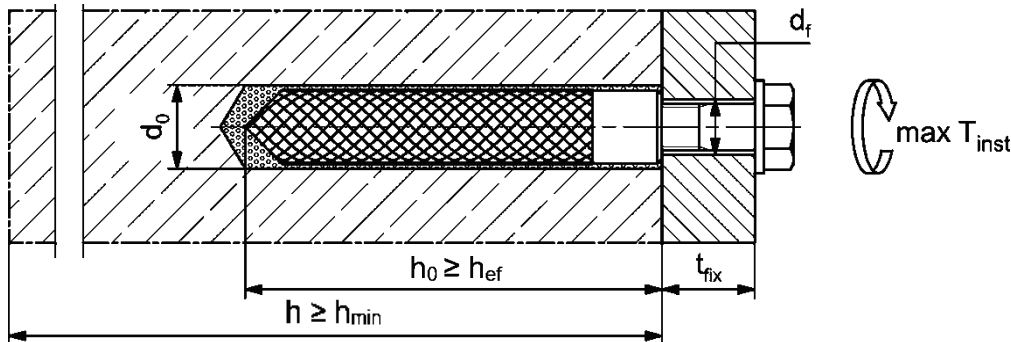

Figures not to scale

fischer Injection System FIS EM PLUS

Intended use
 Installation parameters internal threaded anchors RG M I (metric size)

Annex B9
 Appendix 18 / 28

Table B10.1: Installation parameters for fractional fischer RG M I

fischer RG M I		Thread	3/8"	1/2"	5/8"	3/4"
Diameter of anchor	$d_{nom} = d_H$	[mm]	15,7	18	22	28
Nominal drill hole diameter	d_0	[mm]	18	20	24	32
		[inch]	3/4	13/16	1	1 1/4
Drill hole depth	h_0	[mm]	$h_0 \geq h_{ef} = L_H$			
Effective embedment depth ($h_{ef} = L_H$)	h_{ef}		90	125	160	200
Minimum spacing and minimum edge distance	$s_{min} = c_{min}$		65	75	95	125
	d_f		12	14	18	22
Minimum thickness of concrete member	h_{min}		125	165	205	260
Maximum screw-in depth	$l_{E,max}$		23	26	35	45
Minimum screw-in depth	$l_{E,min}$		10	12	16	20
Maximum installation torque	$\max T_{inst}$		[Nm]	20	40	80

fischer RG M I

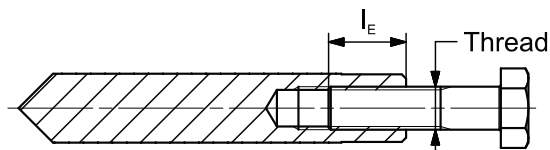
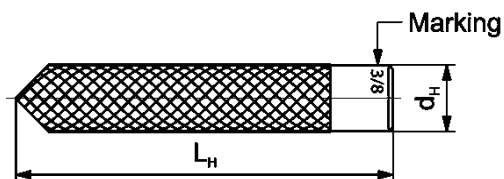

Marking: Anchor size e. g.: **M 3/8**
Stainless steel → additional **R**; e.g.: **M 3/8 R**

Retaining screw or threaded rods (including nut and washer) must comply with the appropriate material and strength class of **Annex A7, Table A7.1**.

Installation conditions:

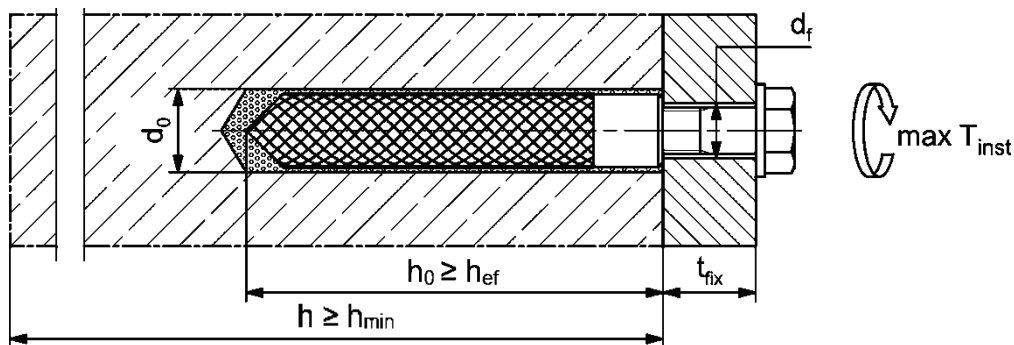

Figures not to scale

fischer Injection System FIS EM PLUS

Intended use
Installation parameters internal threaded anchors RG M I (fractional size)

Annex B10
Appendix 19 / 28

Table B11.1: Installation parameters for metric fischer FIS IG

fischer FIS IG		Thread	M8	M10	M12	M16	M20
Diameter of anchor	$d_{nom} = d_H$	[mm]	12	16	20	24	30
Nominal drill hole diameter	d_0		14	18	22 ¹⁾ 24	28	35
Drill hole depth	h_0 ²⁾		$h_0 \geq h_{ef} = L_H$				
Effective embedment depth ($h_{ef} = L_H$)	$h_{ef, min}$		48	64	80	96	120
	$h_{ef, max}$		240	320	400	480	600
Minimum spacing	s_{min}		according to Annex B6				
Minimum edge distance	c_{min}		according to Annex B6				
Diameter of clearance hole in the fixture	d_f		9	12	14	18	22
Minimum thickness of concrete member	h_{min} ²⁾		$h_{ef} + 30$ (≥ 80)	$h_{ef} + 2d_0$			
Maximum screw-in depth	$l_{E, max}$		20	25	30	40	50
Minimum screw-in depth	$l_{E, min}$	10	12	14	19	23	
Maximum installation torque	$\max T_{inst}$	[Nm]	10	20	40	80	120

¹⁾ Alternative drill hole diameter $d_0 = 22$ mm permissible (does not apply when using centering clips DD-S / DD-E).
²⁾ When using centering clips DD-S / DD-E, observe the deviating specifications according to Table B15.3.

fischer FIS IG

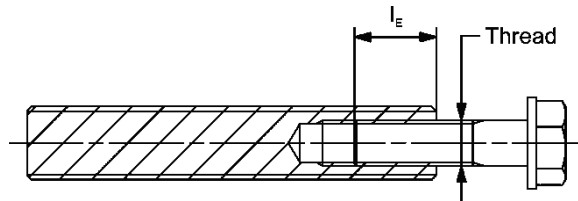
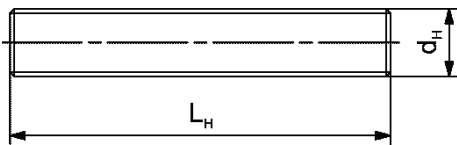

Marking (on random place) anchor rod:

High corrosion resistant steel HCR property class 70

Retaining screw or threaded rods (including nut and washer) must comply with the appropriate material and strength class of **Annex A6, Table A6.1**.

Installation conditions:

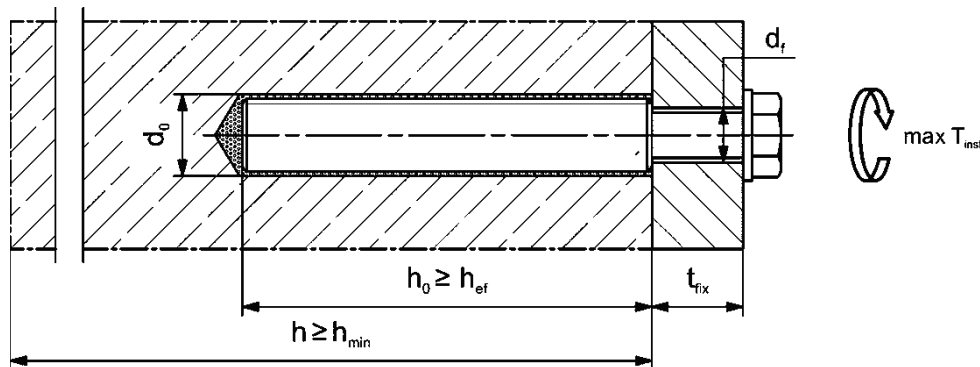

Figures not to scale

fischer Injection System FIS EM PLUS

Intended use

Installation parameters internal threaded anchors FIS IG (metric size)

Annex B11

Appendix 20 / 28

Table B12.1: Installation parameters for metric reinforcing bars

Nominal diameter of the bar		ϕ	8 ¹⁾		10 ¹⁾		12 ¹⁾		14	16	18	20	22	24	
Nominal drill hole diameter	d_0	[mm]	10	12	12	14	14	16	18	20	25	25	30	30	
Drill hole depth	h_0		$h_0 \geq h_{ef}$												
Effective embedment depth	$h_{ef,min}$		60	60	70	75	80	85	90	94	98				
	$h_{ef,max}$		160	200	240	280	320	360	400	440	480				
Minimum spacing	s_{min}		according to Annex B6												
Minimum edge distance	c_{min}		according to Annex B6												
Minimum thickness of concrete member	h_{min}		$h_{ef} + 30$					$h_{ef} + 2d_0$							

Nominal diameter of the bar		ϕ	25	26	28	30	32	34	36	40	-	
Nominal drill hole diameter	d_0	[mm]	30	35	35	40	40	40	45	55	-	
Drill hole depth	h_0		$h_0 \geq h_{ef}$									
Effective embedment depth	$h_{ef,min}$		100	104	112	120	128	136	144	160	-	
	$h_{ef,max}$		500	520	560	600	640	680	720	800	-	
Minimum spacing	s_{min}		according to Annex B6									
Minimum edge distance	c_{min}		according to Annex B6									
Minimum thickness of concrete member	h_{min}		$h_{ef} + 2d_0$									

1) Both drill hole diameters can be used.

Reinforcing bar



- The minimum value of related rib area $f_{R,min}$ must fulfil the requirements of EN 1992-1-1:2004+AC:2010.
- The rib height must be within the range: $0,05 \cdot \phi \leq h_{rib} \leq 0,07 \cdot \phi$
(ϕ = Nominal diameter of the bar, h_{rib} = rib height).

Installation conditions:

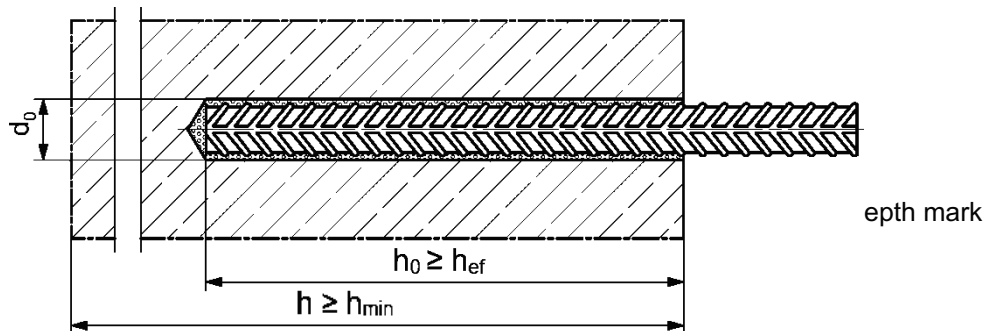

Figures not to scale

fischer Injection System FIS EM PLUS

Intended use
Installation parameters reinforcing bars (metric size)

Annex B12
Appendix 21 / 28

Table B13.1: Installation parameters for fractional reinforcing bars

Rebar size		#3	#4	#5	#6	#7	#8	#9	#10	
Nominal drill hole diameter	d_0	[mm]	12,7	15,9	19,1	22,2	28,6	31,8	34,9	38,1
		[inch]	1/2	5/8	3/4	7/8	1 1/8	1 1/4	1 3/8	1 1/2
Drill hole depth	h_0	$h_0 \geq h_{ef}$								
Effective embedment depth	$h_{ef,min}$	60	70	79	89	89	102	114	127	
	$h_{ef,max}$	191	254	318	381	445	508	572	635	
Minimum spacing	s_{min}	according to Annex B7								
Minimum edge distance	c_{min}	according to Annex B7								
Minimum thickness of concrete member	h_{min}	$h_{ef} + 30$		$h_{ef} + 2d_0$						

Reinforcing bar



Reinforcing bars, acc. to ASTM A615/A615M-22 (ASTM A767/A767M-19).

Materials, dimensions, and mechanical properties according to **Annex A7, Table A7.1**.

Installation conditions:

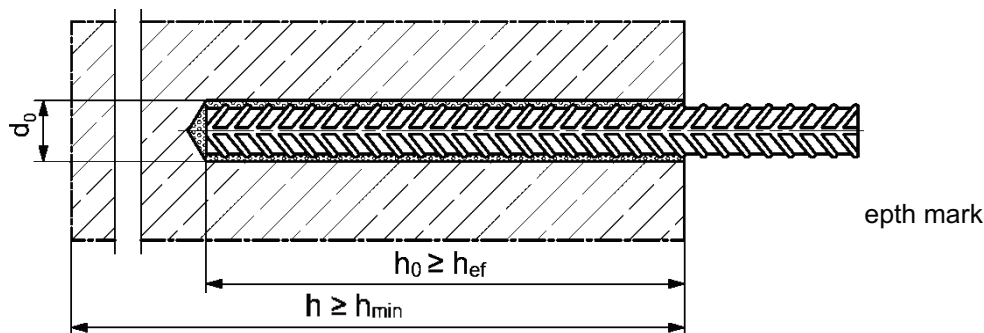

Figures not to scale

fischer Injection System FIS EM PLUS

Intended use
Installation parameters reinforcing bars (fractional size)

Annex B13
Appendix 22 / 28

Table B14.1: Installation parameters for metric fischer FRA

fischer FRA		Thread	M12 ¹⁾	M16	M20	M24	
Nominal diameter of the bar	ϕ	[mm]	12	16	20	25	
Nominal drill hole diameter	d_0		14	16	20	25	30
Drill hole depth	h_0		$h_{ef} + l_e = h_{nom}$				
Effective embedment depth	$h_{ef,min}$		70	80	90	96	
	$h_{ef,max}$		140	220	300	380	
Distance concrete surface to welded joint	l_e		100				
Minimum spacing and minimum edge distance	s_{min}		55	65	85	105	
	c_{min}						
Diameter of clearance hole in the fixture	pre-positioned anchorage $\leq d_f$		14	18	22	26	
	push through anchorage $\leq d_f$		18	22	26	32	
Minimum thickness of concrete member	h_{min}	$h_0 + 30$	$h_0 + 2d_0$				
Maximum installation torque	$\max T_{inst}$	[Nm]	40	60	120	150	

1) Both drill hole diameters can be used.

fischer FRA

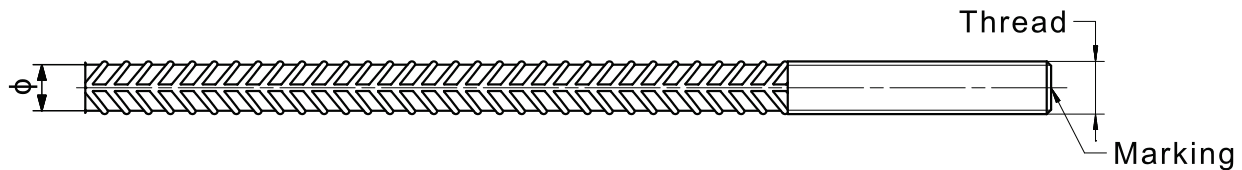

Marking frontal e.g.:

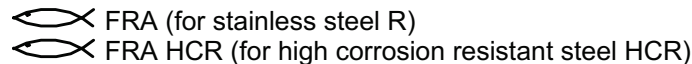

Installation conditions:

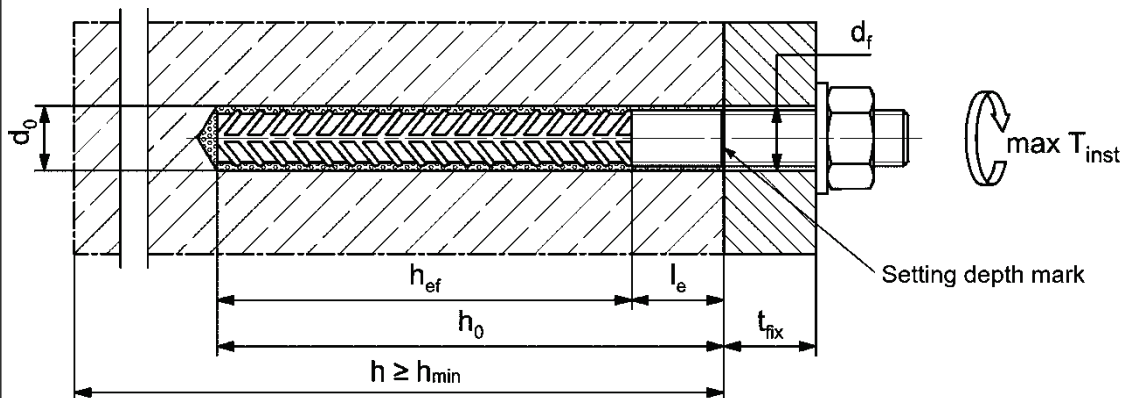

Figures not to scale

fischer Injection System FIS EM PLUS

Intended use

Installation parameters fischer FRA (metric size)

Annex B14

Appendix 23 / 28

Table B15.1: Parameters of the **cleaning brush BS / BSB** (steel brush with steel bristles)
The size of the cleaning brush refers to the drill hole diameter.

Nominal drill hole diameter d_0	[mm]	10	12	14	16	18	20	22	24	25	28	30	32	35	40	45	55
	[inch]	-	7/16	1/2	5/8	3/4	13/16		1	1 1/8	1 1/4	1 3/8	1 1/2	-	-	-	-
Steel brush diameter BS	d_b [mm]	11	14	16	20		25	26	27	30		40		-	-	-	-
Steel brush diameter BSB	d_b [mm]	-	-	-	-	-	-	-	-	-	-	-	-	-	42	47	58

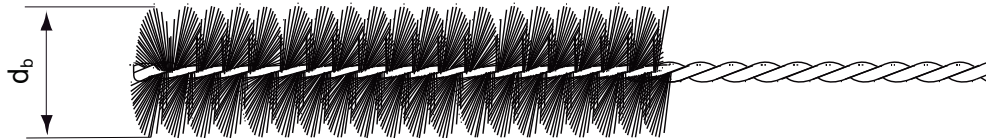

Table B15.2: Conditions for use static mixer without an extension tube

Nominal drill hole diameter d_0	[mm]	10	12	14	16	18	20	22	24	25	28	30	32	35	40	45	55
	[inch]	-	7/16	1/2	5/8	3/4	13/16	-	1	-	1 1/8	1 1/4		1 3/8	1 1/2	-	-
Drill hole depth h_0 by using	FIS MR Plus [mm]	≤90	≤120	≤140	≤150	≤160	≤170	≤190	≤210								
	FIS UMR [mm]	-	≤90			≤260			≤280								

Table B15.3: Parameters of the **fischer centering clip DD-S / DD-E**

Anchor rods / Threaded rods			M12	M16	M20	M24	M27	M30
fischer FIS IG			M8	M10	M12	M16	-	M20
fischer centering clip DD-S / DD-E			M12	M16	M20	M24	M27	M30
fischer centering clip DD-S	h_{DD-S}	[mm]	6,5	8,0	9,0	10,0	10,0	10,0
fischer centering clip DD-E	h_{DD-E}	[mm]	12,0	13,5	18,0	19,0	19,0	19,0
Drill hole depth	h_0	[mm]	$h_0 \geq h_{nom} + 3 \text{ mm}$					
Minimum thickness of concrete member	h_{min}	[mm]	$h_{nom} + 30$ (≥ 80)	$h_{nom} + 2d_0$				

The uppermost DD-S clip should be positioned approx. 5 - 10 mm below the concrete surface.
The effective embedment depth h_{ef} is calculated as follows when using the DD-S / DD-E clips.

$$h_{ef} = h_{nom} - h_{DD-E} - n \cdot h_{DD-S}$$

n = number of DD-S clips used

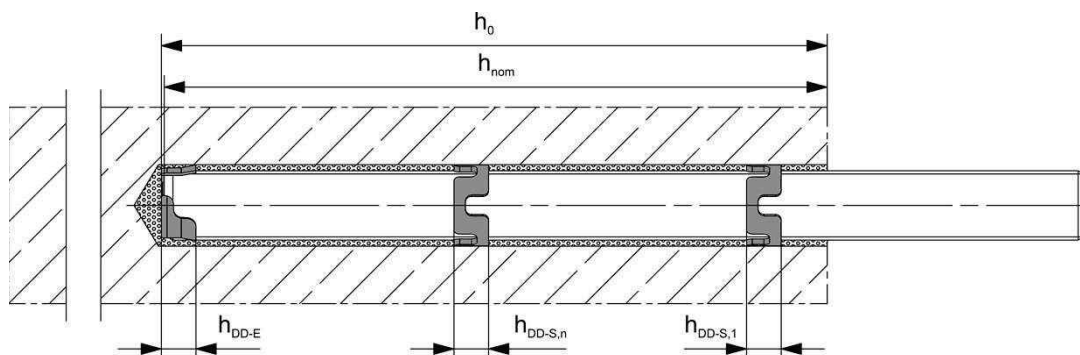

Figures not to scale

fischer Injection System FIS EM PLUS

Intended use
Cleaning brush (steel brush)
fischer centering clip DD-S / DD-E

Annex B15
Appendix 24 / 28

Installation instructions part 1

Drilling and cleaning the hole (hammer drilling with standard drill bit)

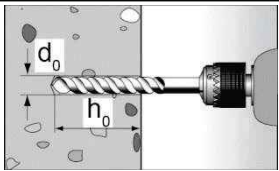
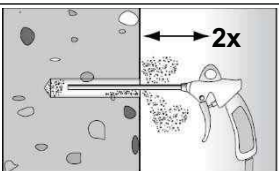
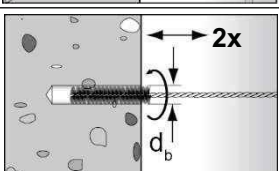
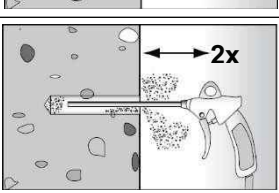
1		Drill the hole. Nominal drill hole diameter d_0 and drill hole depth h_0 see Tables B4.1, B5.1, B9.1, B10.1, B11.1, B12.1, B13.1, B14.1.
2		Cleaning the drill hole: Blow out the drill hole twice, with oil-free compressed air ($p \geq 6$ bar).
3		Brush the drill hole twice. For drill hole diameter ≥ 30 mm use a power drill. For deep holes use an extension. Corresponding brushes see Table B15.1.
4		Cleaning the drill hole: Blow out the drill hole twice, with oil-free compressed air ($p \geq 6$ bar).

Go to step 6

Drilling and cleaning the hole (hammer drilling with hollow drill bit)

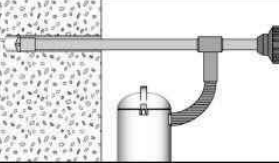
1		Check a suitable hollow drill (see Table B1.1) for correct operation of the dust extraction.
2		Use a suitable dust extraction system, e. g. fischer FVC 35 M or a comparable dust extraction system with equivalent performance data. Drill the hole with hollow drill bit. The dust extraction system has to extract the drill dust nonstop during the drilling process and must be adjusted to maximum power. Nominal drill hole diameter d_0 and drill hole depth h_0 see Tables B4.1, B5.1, B9.1, B10.1, B11.1, B12.1, B13.1, B14.1.

Go to step 6

fischer Injection System FIS EM PLUS

Intended use
Installation instructions part 1



Annex B16
Appendix 25 / 28

Installation instructions part 2

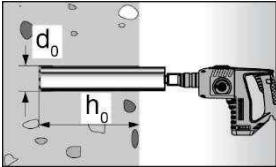
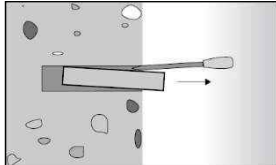
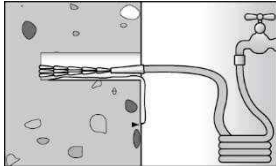
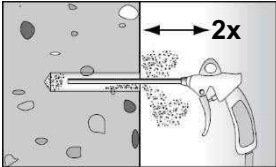
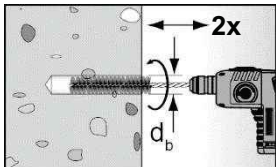
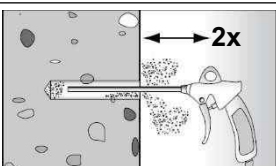
Drilling and cleaning the hole (wet drilling with diamond drill bit)

1		<p>Drill the hole. Drill hole diameter d_0 and nominal drill hole depth h_0 see Tables B4.1, B5.1, B9.1, B10.1, B11.1, B12.1, B13.1, B14.1.</p>	 <p>Break the drill core and remove it.</p>
2		<p>Flush the drill hole with clean water until it flows clear.</p>	
3		<p>Blow out the drill hole twice, using oil-free compressed air ($p > 6$ bar).</p>	
4		<p>Brush the drill hole twice using a power drill. Corresponding brushes see Table B15.1.</p>	
5		<p>Blow out the drill hole twice, using oil-free compressed air ($p > 6$ bar).</p>	

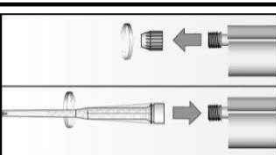
Preparing the cartridge

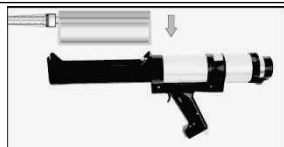
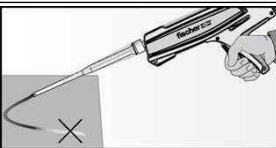
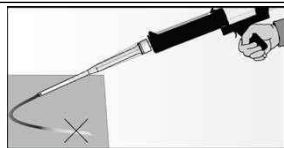
6		<p>Remove the sealing cap. Screw on the static mixer (the spiral in the static mixer must be clearly visible).</p>	
7			<p>Place the cartridge into the dispenser. When using the foilbag, the foil container holder must be used.</p>
8			<p>Extrude approximately 10 cm of material out until the resin is evenly grey in colour. Do not use mortar that is not uniformly grey.</p>

fischer Injection System FIS EM PLUS

Intended use
Installation instructions part 2

Annex B17

Appendix 26 / 28

Installation instructions part 3

Injection of the mortar

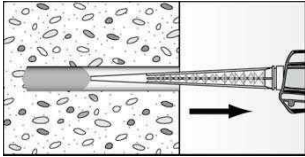
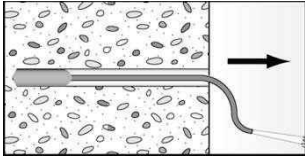
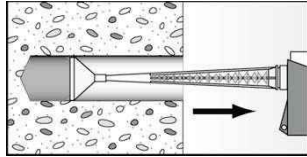
<p>9</p>	 <p>Fill approximately 2/3 of the drill hole with mortar. Always begin from the bottom of the hole and avoid bubbles.</p>	 <p>The conditions for mortar injection without extension tube can be found in Table B15.2. For deeper drill holes, than those mentioned in Table B15.2, use a suitable extension tube.</p>	 <p>For overhead installation, deep holes ($h_0 > 250$ mm) or drill hole diameter ($d_0 \geq 30$ mm / 1 1/8") use an injection-adapter.</p>
----------	--	--	---

Installation Anchor rods, Threaded rods or fischer internal threaded anchors RG M I / FIS IG

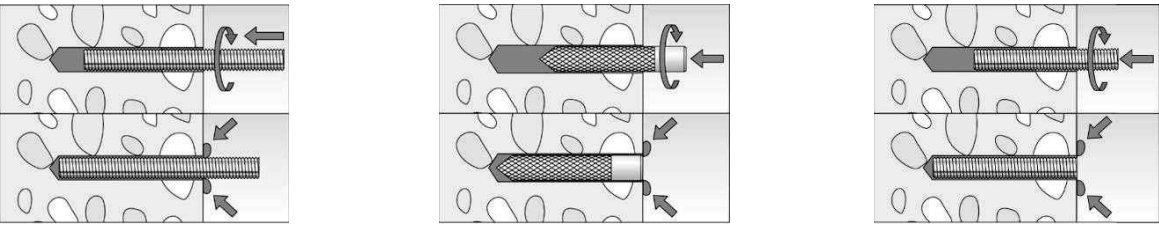
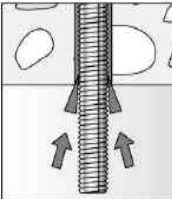
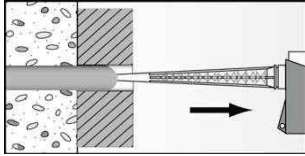
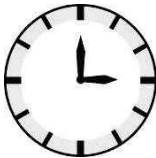
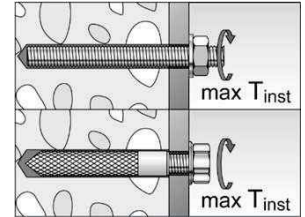
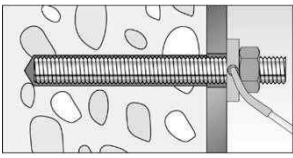
<p>10</p>	 <p>Only use clean and oil-free metal parts. Mark the setting depth of the metal parts. Push the anchor rod / threaded rod or fischer RG M I / FIS IG anchor down to the bottom of the hole, turning it slightly while doing so. No turning movement is permitted when using the DD-S / DD-E centering clips. After inserting the metal part, excess mortar must be emerged around the anchor element. If not, pull out the metal part immediately and reinject mortar.</p>
 <p>For overhead installations support the metal part with wedges (e.g., fischer centering wedges), fischer overhead clips or fischer centering clips.</p>	 <p>For push through installation, fill the annular gap with mortar.</p>
<p>11</p>  <p>Wait for the curing time t_{cure}, see Table B19.1.</p>	<p>12</p>  <p>Mounting the fixture max T_{inst} see Tables B4.1, B5.1, B9.1, B10.1, B11.1.</p>
<p>Option</p>	 <p>After the minimum curing time is reached, the gap between metal part and fixture (annular clearance) may be filled with mortar via the fischer filling disc. Compressive strength ≥ 50 N/mm² (e.g., fischer injection mortars FIS EM Plus, FIS HB, FIS SB, FIS V Plus). ATTENTION: Using fischer filling disc reduces t_{fix} (usable length of the anchor).</p>

fischer Injection System FIS EM PLUS

Intended use
Installation instructions part 3

Annex B18
Appendix 27 / 28

Installation instructions part 4

Installation reinforcing bars and fischer FRA



10		<p>Only use clean and oil-free reinforcing bars or fischer FRA. Mark the setting depth. Turn while using force to push the reinforcement bar or the fischer FRA into the filled hole up to the setting depth mark.</p>	
		<p>When the setting depth mark is reached, excess mortar must be emerged from the mouth of the drill hole. If not, pull out the anchor element immediately and reinject mortar.</p>	
11	 <p>Wait for the curing time t_{cure}, see Table B19.1.</p>	12	 <p>Mounting the fixture $\max T_{\text{inst}}$ see Table B14.1.</p>

Table B19.1: Maximum processing time of the mortar and minimum curing time
 (During the curing time of the mortar the concrete temperature may not fall below the listed minimum temperature)

Temperature at anchoring base [°C]	Maximum processing time t_{work}	Minimum curing time ¹⁾ t_{cure}
-5 to 0 ²⁾	240 min	200 h
> 0 to 5 ²⁾	150 min	90 h
> 5 to 10	120 min	40 h
> 10 to 20	30 min	18 h
> 20 to 30	14 min	10 h
> 30 to 40	7 min	5 h

¹⁾ In wet concrete or water filled holes the curing times must be doubled.

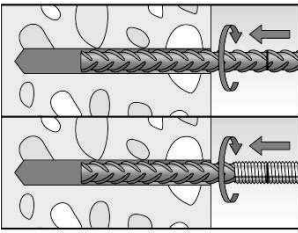
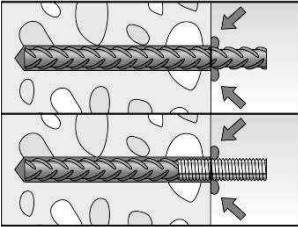
²⁾ Minimal cartridge temperature +5 °C

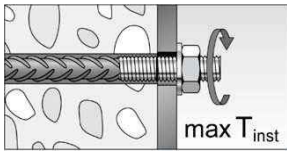
fischer Injection System FIS EM PLUS

Intended use

Installation instructions part 4
 Processing time and curing time

Annex B19

Appendix 28 / 28

Table C1.1: Characteristic resistance to steel failure under tension / shear loading of metric Anchor rods / Threaded rods

Anchor rod / Threaded rod		M8	M10	M12	M14	M16	M20	M22	M24	M27	M30			
Characteristic resistance to steel failure under tension loading ¹⁾														
Characteristic resistance $N_{Rk,s}$	Steel zinc plated	Property class	4.8	[kN]	14,6(13,2)	23,2(21,4)	33,7	46,0	62,8	98,0	121,2	141,2	183,6	224,4
			5.8		18,3(16,6)	29,0(26,8)	42,1	57,5	78,5	122,5	151,5	176,5	229,5	280,5
			8.8		29,2(26,5)	46,4(42,8)	67,4	92,0	125,6	196,0	242,4	282,4	367,2	448,8
	Stainless steel R and high corrosion resistant steel HCR		50		18,3	29,0	42,1	57,5	78,5	122,5	151,5	176,5	229,5	280,5
			70		25,6	40,6	59,0	80,5	109,9	171,5	212,1	247,1	321,3	392,7
			80		29,2	46,4	67,4	92,0	125,6	196,0	242,4	282,4	367,2	448,8
Partial factors ²⁾														
Partial factor $\gamma_{Ms,N}$	Steel zinc plated	Property class	4.8	[-]	1,50									
			5.8		1,50									
			8.8		1,50									
	Stainless steel R and high corrosion resistant steel HCR		50		2,86									
			70		1,87 / fischer HCR: 1,50 ³⁾									
			80		1,60									
Characteristic resistance to steel failure under shear loading ¹⁾														
Without lever arm														
Characteristic resistance $V_{Rk,s}^0$	Steel zinc plated	Property class	4.8	[kN]	8,7(7,9)	13,9(12,8)	20,2	27,6	37,6	58,8	72,7	84,7	110,1	134,6
			5.8		10,9(9,9)	17,4(16,0)	25,2	34,5	47,1	73,5	90,9	105,9	137,7	168,3
			8.8		14,6(13,2)	23,2(21,4)	33,7	46,0	62,8	98,0	121,2	141,2	183,6	224,4
	Stainless steel R and high corrosion resistant steel HCR		50		9,1	14,5	21,0	28,7	39,2	61,2	75,7	88,2	114,7	140,2
			70		12,8	20,3	29,5	40,2	54,9	85,7	106,0	123,5	160,6	196,3
			80		14,6	23,2	33,7	46,0	62,8	98,0	121,2	141,2	183,6	224,4
Ductility factor	k_7	[-]	1,0											
With lever arm														
Charact. resistance $M_{Rk,s}^0$	Steel zinc plated	Property class	4.8	[Nm]	14,9(12,9)	29,9(26,5)	52,3	83,5	132,9	259,6	357,1	448,8	665,7	899,5
			5.8		18,7(16,1)	37,3(33,2)	65,4	104,4	166,2	324,6	446,4	561,0	832,2	1124,4
			8.8		29,9(25,9)	59,8(53,1)	104,6	167,0	265,9	519,3	714,2	897,6	1331,5	1799,0
	Stainless steel R and high corrosion resistant steel HCR		50		18,7	37,3	65,4	104,4	166,2	324,6	446,4	561,0	832,2	1124,4
			70		26,2	52,3	91,5	146,1	232,6	454,4	624,9	785,4	1165,0	1574,1
			80		29,9	59,8	104,6	167,0	265,9	519,3	714,2	897,6	1331,5	1799,0
Partial factors ²⁾														
Partial factor $\gamma_{Ms,V}$	Steel zinc plated	Property class	4.8	[-]	1,25									
			5.8		1,25									
			8.8		1,25									
	Stainless steel R and high corrosion resistant steel HCR		50		2,38									
			70		1,56 / fischer HCR: 1,25 ³⁾									
			80		1,33									

¹⁾ Values in brackets are valid for undersized threaded rods with smaller stress area A_s for hot dip galvanised Threaded rods according to EN ISO 10684:2004+AC:2009.

²⁾ In absence of other national regulations.

³⁾ Only admissible for high corrosion resistant steel HCR, acc. to Table A6.1.

fischer Injection System FIS EM PLUS

Performance

Characteristic resistance to steel failure under tension / shear loading of metric Anchor rods / Threaded rods

Annex C1

Appendix 29 / 28

Table C2.1: Characteristic resistance to steel failure under tension / shear loading of metric fischer RG M I

fischer RG M I				M8	M10	M12	M16	M20	
Characteristic resistance to steel failure under tension loading									
Characteristic resistance with Screw or Threaded / Anchor rod $N_{Rk,s}$	Steel zinc plated	Property class of Screw or Threaded / Anchor rod	5.8	[kN]	18,3	29,0	42,1	78,3	122,4
			8.8		29,2	46,4	67,4	106,7	180,2
	Stainless steel R and High corrosion resistant steel HCR		70		25,6	40,6	59,0	109,6	171,3
Partial factors ¹⁾									
Partial factor $\gamma_{Ms,N}$	Steel zinc plated	Property class of Screw or Threaded / Anchor rod	5.8	[-]	1,50				
			8.8		1,50				
	Stainless steel R and High corrosion resistant steel HCR		70		1,87 / fischer HCR: 1,50 ²⁾				
Characteristic resistance to steel failure under shear loading									
Without lever arm									
Characteristic resistance with Screw or Threaded / Anchor rod $V_{Rk,s}$	Steel zinc plated	Property class of Screw or Threaded / Anchor rod	5.8	[kN]	10,9	17,4	25,2	47,1	73,5
			8.8		14,6	23,2	33,7	62,8	98,0
	Stainless steel R and High corrosion resistant steel HCR		70		12,8	20,3	29,5	54,9	85,7
Ductility factor			k_7	[-]	1,0				
With lever arm									
Characteristic resistance with Screw or Threaded / Anchor rod $M^0_{Rk,s}$	Steel zinc plated	Property class of Screw or Threaded / Anchor rod	5.8	[Nm]	18,7	37,3	65,4	166,2	324,6
			8.8		29,9	59,8	104,6	265,9	519,3
	Stainless steel R and High corrosion resistant steel HCR		70		26,2	52,3	91,5	232,6	454,4
Partial factors ¹⁾									
Partial factor $\gamma_{Ms,V}$	Steel zinc plated	Property class of Screw or Threaded / Anchor rod	5.8	[-]	1,25				
			8.8		1,25				
	Stainless steel R and High corrosion resistant steel HCR		70		1,56 / fischer HCR: 1,25 ²⁾				

¹⁾ In absence of other national regulations.

²⁾ Only admissible for high corrosion resistant steel HCR, acc. to Table A6.1.

fischer Injection System FIS EM PLUS

Performance

Characteristic resistance to steel failure under tension / shear loading of metric fischer RG M I

Annex C2

Table C3.1: Characteristic resistance to steel failure under tension / shear loading of metric fischer FIS IG

fischer FIS IG				M8	M10	M12	M16	M20	
Characteristic resistance to steel failure under tension loading									
Characteristic resistance with Screw or Threaded / Anchor rod $N_{Rk,s}$	Steel zinc plated	Property class of Screw or Threaded / Anchor rod	5.8	[kN]	18,3	29,0	42,1	78,3	122,4
			8.8		23,0	46,4	67,4	96,9	156,8
	Stainless steel R and High corrosion resistant steel HCR		70		25,6	40,6	59,0	109,6	171,3
Partial factors ¹⁾									
Partial factor $\gamma_{Ms,N}$	Steel zinc plated	Property class of Screw or Threaded / Anchor rod	5.8	[-]	1,50				
			8.8		1,50				
	Stainless steel R and High corrosion resistant steel HCR		70		1,87 / fischer HCR: 1,50 ²⁾				
Characteristic resistance to steel failure under shear loading									
Without lever arm									
Characteristic resistance with Screw or Threaded / Anchor rod $V_{Rk,s}^0$	Steel zinc plated	Property class of Screw or Threaded / Anchor rod	5.8	[kN]	10,9	17,4	25,2	47,1	73,5
			8.8		14,6	23,2	33,7	62,8	98,0
	Stainless steel R and High corrosion resistant steel HCR		70		12,8	20,3	29,5	54,9	85,7
Ductility factor			k_7	[-]	1,0				
With lever arm									
Characteristic resistance with Screw or Threaded / Anchor rod $M_{Rk,s}^0$	Steel zinc plated	Property class of Screw or Threaded / Anchor rod	5.8	[Nm]	18,7	37,3	65,4	166,2	324,6
			8.8		29,9	59,8	104,6	265,9	519,3
	Stainless steel R and High corrosion resistant steel HCR		70		26,2	52,3	91,5	232,6	454,4
Partial factors ¹⁾									
Partial factor $\gamma_{Ms,V}$	Steel zinc plated	Property class of Screw or Threaded / Anchor rod	5.8	[-]	1,25				
			8.8		1,25				
	Stainless steel R and High corrosion resistant steel HCR		70		1,56 / fischer HCR: 1,25 ²⁾				

1) In absence of other national regulations.

2) Only admissible for high corrosion resistant steel HCR, acc. to Table A6.1.

fischer Injection System FIS EM PLUS

Performance

Characteristic resistance to steel failure under tension / shear loading of metric fischer FIS IG

Annex C3

Table C4.1: Characteristic resistance to steel failure under tension / shear loading of metric reinforcing bars

Nominal diameter of the bar		ϕ	8 to 40
Characteristic resistance to steel failure under tension loading			
Characteristic resistance	$N_{Rk,s}$	[kN]	$A_s \cdot f_{uk}^{1)}$
Characteristic resistance to steel failure under shear loading			
Without lever arm			
Characteristic resistance	$V^0_{Rk,s}$	[kN]	$k_6^{2)}) \cdot A_s \cdot f_{uk}^{1)}$
Ductility factor	k_7	[-]	1,0
With lever arm			
Characteristic resistance	$M^0_{Rk,s}$	[Nm]	$1,2 \cdot W_{el} \cdot f_{uk}^{1)}$

1) f_{uk} respectively shall be taken from the specifications of the reinforcing bar.

2) In accordance with EN 1992-4:2018 section 7.2.2.3.1:

- $k_6 = 0,6$ for fasteners made of carbon steel with $f_{uk} \leq 500 \text{ N/mm}^2$,
- $= 0,5$ for fasteners made of carbon steel with $500 \text{ N/mm}^2 < f_{uk} \leq 1000 \text{ N/mm}^2$,
- $= 0,5$ for fasteners made of stainless steel.

Table C4.2: Characteristic resistance to steel failure under tension / shear loading of metric fischer FRA

fischer FRA		M12	M16	M20	M24	
Characteristic resistance to steel failure under tension loading						
Characteristic resistance	$N_{Rk,s}$	[kN]	62,0	111,0	173,0	236,5
Partial factor 1)						
Partial factor	$\gamma_{Ms,N}$	[-]	1,40			
Characteristic resistance to steel failure under shear loading						
Without lever arm						
Characteristic resistance	$V^0_{Rk,s}$	[kN]	34,5	64,3	100,4	144,7
Ductility factor	k_7	[-]	1,0			
With lever arm						
Characteristic resistance	$M^0_{Rk,s}$	[Nm]	107,4	273,0	532,2	920,4
Partial factor 1)						
Partial factor	$\gamma_{Ms,V}$	[-]	1,50			

1) In absence of other national regulations.

fischer Injection System FIS EM PLUS

Performance

Characteristic resistance to steel failure under tension / shear loading of metric reinforcing bars and metric fischer FRA

Annex C4

Appendix 32 / 28

Table C5.1: Characteristic resistance for concrete failure under tension / shear loading (metric size)

Size		All sizes																	
Tension loading																			
Installation factor	γ_{inst}	[-]	See annex C6 to C19 and C43 to C45																
Factors for the compressive strength of concrete > C20/25																			
Increasing factor ψ_c for cracked or uncracked concrete $\tau_{Rk(X,Y)} = \psi_c \cdot \tau_{Rk(C20/25)}$	C25/30	ψ_c	[-]	1,02															
	C30/37			1,04															
	C35/45			1,06															
	C40/50			1,07															
	C45/55			1,08															
	C50/60			1,09															
Splitting failure																			
Edge distance	$h / h_{ef} \geq 2,0$	$C_{cr,sp}$	[mm]	1,0 h_{ef}															
	$2,0 > h / h_{ef} > 1,3$			4,6 $h_{ef} - 1,8 h$															
	$h / h_{ef} \leq 1,3$			2,26 h_{ef}															
Spacing	$S_{cr,sp}$			2 $c_{cr,sp}$															
Concrete cone failure																			
Uncracked concrete	$k_{ucr,N}$	[-]	11,0																
Cracked concrete	$k_{cr,N}$		7,7																
Edge distance	$C_{cr,N}$	[mm]	1,5 h_{ef}																
Spacing	$S_{cr,N}$		2 $c_{cr,N}$																
Factors for sustained tension loading																			
Temperature range				24 °C / 40 °C				35 °C / 60 °C				50 °C / 72 °C							
Factor	ψ_{sus}^0	[-]	1,0				1,0				0,7								
Factor	$\psi_{sus,100}^0$	[-]	1,0				1,0				1,0								
Shear loading																			
Installation factor	γ_{inst}	[-]	1,0																
Concrete pry-out failure																			
Factor for pry-out failure	k_8	[-]	2,0																
Concrete edge failure																			
Effective length of fastener for shear loading	l_f	[mm]	for $d_{nom} \leq 24$ mm: min (h_{ef} ; 12 d_{nom}) for $d_{nom} > 24$ mm: min (h_{ef} ; max (8 d_{nom} ; 300 mm))																
Effective diameter of the fastener d_{nom}																			
Size				M8	M10	M12	M14	M16	M20	M22	M24	M27	M30						
Anchor rods and Threaded rods	d_{nom}	[mm]	8	10	12	14	16	20	22	24	27	30							
fischer RG M I	d_{nom}		12,0	15,7	18,0	- ¹⁾	22,0	28,0	- ¹⁾	- ¹⁾	- ¹⁾	- ¹⁾							
fischer FIS IG	d_{nom}		12	16	20	- ¹⁾	24	30	- ¹⁾	- ¹⁾	- ¹⁾	- ¹⁾							
fischer FRA	d_{nom}		- ¹⁾	- ¹⁾	12	- ¹⁾	16	20	- ¹⁾	25	- ¹⁾	- ¹⁾							
Size (nominal diameter of the bar)	ϕ		8	10	12	14	16	18	20	22	24	25	26	28	30	32	34	36	40
Reinforcing bar	d_{nom}	[mm]	8	10	12	14	16	18	20	22	24	25	26	28	30	32	34	36	40

¹⁾ Anchor type not part of the assessment.

fischer Injection System FIS EM PLUS

Performance

Characteristic resistance for concrete failure under tension / shear loading (metric size)

Annex C5

Appendix 33 / 28

Table C6.1: Characteristic resistance to combined pull-out and concrete failure for metric Anchor rods and Threaded rods in hammer or diamond drilled holes; uncracked or cracked concrete; working life 50 years

Anchor rod / Threaded rod		M8 ¹⁾	M10	M12	M14	M16	M20	M22	M24	M27	M30	
Combined pull-out and concrete cone failure												
Calculation diameter	d	[mm]	8	10	12	14	16	20	22	24	27	30
Uncracked concrete												
Characteristic bond resistance in uncracked concrete C20/25												
Hammer-drilling with standard drill bit or hollow drill bit (dry or wet concrete)												
Temperature range	I: 24 °C / 40 °C	$\tau_{Rk,ucr}$ [N/mm ²]	20,8	19,7	18,8	18,1	17,6	16,7	16,3	16,0	15,5	15,1
	II: 35 °C / 60 °C		18,0	18,0	18,0	17,0	17,0	16,0	15,0	15,0	15,0	14,0
	III: 50 °C / 72 °C		18,0	17,0	17,0	16,0	16,0	15,0	14,0	14,0	14,0	13,0
Hammer-drilling with standard drill bit or hollow drill bit (water filled hole)												
Temperature range	I: 24 °C / 40 °C	$\tau_{Rk,ucr}$ [N/mm ²]	20,8	19,7	18,8	17,9	16,9	15,3	14,4	13,8	13,2	12,3
	II: 35 °C / 60 °C		16,0	16,0	15,0	13,0	13,0	11,0	11,0	10,0	10,0	9,0
	III: 50 °C / 72 °C		15,0	14,0	14,0	13,0	12,0	11,0	10,0	10,0	9,0	9,0
Installation factors; Hammer-drilling with standard drill bit or hollow drill bit												
Dry or wet concrete	γ_{inst}	[-]	1,0									
Water filled hole			1,4									
Diamond-drilling (dry or wet concrete)												
Temperature range	I: 24 °C / 40 °C	$\tau_{Rk,ucr}$ [N/mm ²]	16,0	15,0	13,5	12,8	12,4	11,6	11,3	10,9	10,5	10,3
	II: 35 °C / 60 °C		16,0	15,0	13,0	12,0	12,0	10,0	10,0	10,0	9,0	9,0
	III: 50 °C / 72 °C		15,0	14,0	12,0	11,0	11,0	10,0	9,0	9,0	8,0	8,0
Diamond-drilling (water filled hole)												
Temperature range	I: 24 °C / 40 °C	$\tau_{Rk,ucr}$ [N/mm ²]	16,0	16,8	15,5	14,3	13,6	12,0	11,5	10,9	10,3	9,9
	II: 35 °C / 60 °C		16,0	15,0	13,0	12,0	12,0	10,0	10,0	10,0	9,0	9,0
	III: 50 °C / 72 °C		15,0	14,0	12,0	11,0	11,0	10,0	9,0	9,0	8,0	8,0
Installation factors; Diamond-drilling												
Dry or wet concrete	γ_{inst}	[-]	1,0									
Water filled hole			1,4									
Cracked concrete												
Characteristic bond resistance in cracked concrete C20/25												
Hammer-drilling with standard drill bit or hollow drill bit (dry or wet concrete)												
Temperature range	I: 24 °C / 40 °C	$\tau_{Rk,cr}$ [N/mm ²]	7,7	9,0	10,1	9,8	9,5	8,5	8,5	8,5	8,5	8,5
	II: 35 °C / 60 °C		7,7	9,0	10,1	9,8	9,5	8,5	8,5	8,5	8,5	8,5
	III: 50 °C / 72 °C		7,2	8,5	9,5	9,2	8,9	8,5	8,5	8,5	8,5	8,5
Hammer-drilling with standard drill bit or hollow drill bit (water filled hole)												
Temperature range	I: 24 °C / 40 °C	$\tau_{Rk,cr}$ [N/mm ²]	6,6	7,7	8,7	8,3	7,7	6,0	6,0	6,0	6,0	6,0
	II: 35 °C / 60 °C		6,6	7,7	8,7	8,3	7,7	6,0	6,0	6,0	6,0	6,0
	III: 50 °C / 72 °C		6,2	7,3	8,1	7,9	7,3	6,0	6,0	6,0	6,0	6,0
Installation factors; Hammer-drilling with standard drill bit or hollow drill bit												
Dry or wet concrete	γ_{inst}	[-]	1,0									
Water filled hole			1,2			1,4						
Diamond-drilling (dry or wet concrete)												
Temperature range	I: 24 °C / 40 °C	$\tau_{Rk,cr}$ [N/mm ²]	7,0	7,0	7,0	7,0	6,0	6,0	7,0	7,0	7,0	7,0
	II: 35 °C / 60 °C		7,0	7,0	7,0	7,0	6,0	6,0	7,0	7,0	7,0	7,0
	III: 50 °C / 72 °C		7,0	7,0	7,0	7,0	6,0	6,0	7,0	7,0	7,0	7,0
Diamond-drilling (water filled hole)												
Temperature range	I: 24 °C / 40 °C	$\tau_{Rk,cr}$ [N/mm ²]	6,0	7,5	7,5	7,0	6,0	6,0	6,0	6,0	6,0	6,0
	II: 35 °C / 60 °C		6,0	7,5	7,5	7,0	6,0	6,0	6,0	6,0	6,0	6,0
	III: 50 °C / 72 °C		6,0	7,0	7,0	7,0	6,0	6,0	6,0	6,0	6,0	6,0
Installation factors; Diamond-drilling												
Dry or wet concrete	γ_{inst}	[-]	1,0									
Water filled hole			1,2			1,4						

¹⁾ Not allowed for hollow drill bit.

fischer Injection System FIS EM PLUS

Performance

Characteristic resistance to combined pull-out and concrete failure for Anchor rods and Threaded rods; working life 50 years

Annex C6

Appendix 34 / 28

Table C7.1: Characteristic resistance to combined pull-out and concrete failure for metric Anchor rods and Threaded rods in hammer or diamond drilled holes; uncracked or cracked concrete; working life 100 years

Anchor rod / Threaded rod		M8 ¹⁾	M10	M12	M14	M16	M20	M22	M24	M27	M30	
Combined pull-out and concrete cone failure												
Calculation diameter	d	[mm]	8	10	12	14	16	20	22	24	27	30
Uncracked concrete												
Characteristic bond resistance in uncracked concrete C20/25												
<u>Hammer-drilling with standard drill bit or hollow drill bit (dry or wet concrete)</u>												
Temperature range	I: 24 °C / 40 °C	$\tau_{Rk,100,ucr}$ [N/mm ²]	17,1	16,1	15,4	14,9	14,4	13,7	13,4	13,1	12,7	12,4
	II: 35 °C / 60 °C		13,5	13,5	13,5	12,8	12,8	12,0	11,3	11,3	11,3	10,5
	III: 50 °C / 72 °C		9,9	10,2	10,2	10,4	10,4	9,8	9,1	9,1	9,1	8,5
<u>Hammer-drilling with standard drill bit or hollow drill bit (water filled hole)</u>												
Temperature range	I: 24 °C / 40 °C	$\tau_{Rk,100,ucr}$ [N/mm ²]	17,1	16,2	15,4	14,7	13,9	12,5	11,8	11,3	10,8	10,1
	II: 35 °C / 60 °C		12,0	12,0	11,3	9,8	9,8	8,3	8,3	7,5	7,5	6,8
	III: 50 °C / 72 °C		8,3	8,4	8,4	8,5	7,8	7,2	6,5	6,5	5,9	5,9
Installation factors; Hammer-drilling with standard drill bit or hollow drill bit												
Dry or wet concrete	γ_{inst}	[-]	1,0									
Water filled hole			1,4									
<u>Diamond-drilling (dry or wet concrete)</u>												
Temperature range	I: 24 °C / 40 °C	$\tau_{Rk,100,ucr}$ [N/mm ²]	12,0	12,3	11,6	11,1	10,5	10,1	9,5	9,3	8,9	8,8
	II: 35 °C / 60 °C		12,0	11,3	9,8	9,0	9,0	7,5	7,5	7,5	6,8	6,8
	III: 50 °C / 72 °C		8,3	8,4	7,2	7,2	7,2	6,5	5,9	5,9	5,2	5,2
<u>Diamond-drilling (water filled hole)</u>												
Temperature range	I: 24 °C / 40 °C	$\tau_{Rk,100,ucr}$ [N/mm ²]	12,0	13,8	12,7	11,7	11,2	10,0	9,4	8,9	8,4	8,1
	II: 35 °C / 60 °C		12,0	11,3	9,8	9,0	9,0	7,5	7,5	7,5	6,8	6,8
	III: 50 °C / 72 °C		8,3	8,4	7,2	7,2	7,2	6,5	5,9	5,9	5,2	5,2
Installation factors												
Dry or wet concrete	γ_{inst}	[-]	1,0									
Water filled hole			1,4									
Cracked concrete												
Characteristic bond resistance in cracked concrete C20/25												
<u>Hammer-drilling with standard drill bit or hollow drill bit (dry or wet concrete)</u>												
Temperature range	I: 24 °C / 40 °C	$\tau_{Rk,100,cr}$ [N/mm ²]	5,7	7,0	7,6	7,4	7,2	6,9	6,8	6,7	6,5	6,3
	II: 35 °C / 60 °C		5,7	7,0	7,6	7,4	7,2	6,9	6,8	6,7	6,5	6,3
	III: 50 °C / 72 °C		5,4	6,6	7,2	7,0	6,8	6,4	6,4	6,3	6,1	6,0
<u>Hammer-drilling with standard drill bit or hollow drill bit (water filled hole)</u>												
Temperature range	I: 24 °C / 40 °C	$\tau_{Rk,100,cr}$ [N/mm ²]	4,9	6,0	6,5	6,1	5,9	4,9	4,8	4,7	4,6	4,4
	II: 35 °C / 60 °C		4,9	6,0	6,5	6,1	5,9	4,9	4,8	4,7	4,6	4,4
	III: 50 °C / 72 °C		4,6	5,7	6,1	5,7	5,5	4,5	4,5	4,4	4,3	4,3
Installation factors; Hammer-drilling with standard drill bit or hollow drill bit												
Dry or wet concrete	γ_{inst}	[-]	1,0									
Water filled hole			1,2				1,4					
<u>Diamond-drilling (dry or wet concrete)</u>												
Temperature range	I: 24 °C / 40 °C	$\tau_{Rk,100,cr}$ [N/mm ²]	4,2	6,0	5,6	4,6	3,9	3,9	4,6	4,6	4,6	4,6
	II: 35 °C / 60 °C		4,2	6,0	5,6	4,6	3,9	3,9	4,6	4,6	4,6	4,6
	III: 50 °C / 72 °C		4,2	6,0	5,6	4,6	3,9	3,9	4,6	4,6	4,6	4,6
Installation factors												
Dry or wet concrete	γ_{inst}	[-]	1,0									

¹⁾ Not allowed for hollow drill bit.

fischer Injection System FIS EM PLUS

Performance

Characteristic resistance to combined pull-out and concrete failure for Anchor rods and Threaded rods in hammer or diamond drilled holes; working life 100 years

Annex C7

Appendix 35 / 28

Table C8.1: Characteristic resistance to combined pull-out and concrete failure for metric fischer RG M I in hammer or diamond drilled holes; uncracked or cracked concrete; working life 50 years

fischer RG M I			M8	M10	M12	M16	M20	
Combined pull-out and concrete cone failure								
Calculation diameter	d	[mm]	12	15,7	18	22	28	
Uncracked concrete								
Characteristic bond resistance in uncracked concrete C20/25								
Hammer-drilling with standard drill bit or hollow drill bit (dry or wet concrete)								
Temperature range	I: 24 °C / 40 °C	$\tau_{Rk,ucr}$	[N/mm ²]	18,8	17,6	17,0	16,2	15,3
	II: 35 °C / 60 °C			15,0	14,0	14,0	13,0	12,0
	III: 50 °C / 72 °C			14,0	13,0	13,0	12,0	11,0
Hammer-drilling with standard drill bit or hollow drill bit (water filled hole)								
Temperature range	I: 24 °C / 40 °C	$\tau_{Rk,ucr}$	[N/mm ²]	18,8	16,9	15,8	14,3	12,8
	II: 35 °C / 60 °C			14,0	12,0	12,0	11,0	10,0
	III: 50 °C / 72 °C			13,0	12,0	11,0	10,0	9,0
Installation factors; Hammer-drilling with standard drill bit or hollow drill bit								
Dry or wet concrete		γ_{inst}	[-]	1,0				
Water filled hole				1,4				
Diamond-drilling (dry or wet concrete)								
Temperature range	I: 24 °C / 40 °C	$\tau_{Rk,ucr}$	[N/mm ²]	13,3	12,3	11,9	11,2	10,4
	II: 35 °C / 60 °C			13,0	12,0	11,0	10,0	9,0
	III: 50 °C / 72 °C			12,0	11,0	10,0	9,0	8,0
Diamond-drilling (water filled hole)								
Temperature range	I: 24 °C / 40 °C	$\tau_{Rk,ucr}$	[N/mm ²]	15,1	13,6	12,6	11,4	10,2
	II: 35 °C / 60 °C			13,0	12,0	11,0	10,0	9,0
	III: 50 °C / 72 °C			12,0	11,0	10,0	9,0	8,0
Installation factors; Diamond-drilling								
Dry or wet concrete		γ_{inst}	[-]	1,0				
Water filled hole				1,4				
Cracked concrete								
Characteristic bond resistance in cracked concrete C20/25								
Hammer-drilling with standard drill bit or hollow drill bit (dry or wet concrete)								
Temperature range	I: 24 °C / 40 °C	$\tau_{Rk,cr}$	[N/mm ²]	7,0	6,0	6,0	7,0	7,0
	II: 35 °C / 60 °C			7,0	6,0	6,0	7,0	7,0
	III: 50 °C / 72 °C			7,0	6,0	6,0	7,0	7,0
Hammer-drilling with standard drill bit or hollow drill bit (water filled hole)								
Temperature range	I: 24 °C / 40 °C	$\tau_{Rk,cr}$	[N/mm ²]	7,0	6,5	6,0	6,0	6,0
	II: 35 °C / 60 °C			7,0	6,5	6,0	6,0	6,0
	III: 50 °C / 72 °C			7,0	6,0	6,0	6,0	6,0
Installation factors; Hammer-drilling with standard drill bit or hollow drill bit								
Dry or wet concrete		γ_{inst}	[-]	1,0				
Water filled hole				1,2		1,4		
Diamond-drilling (dry or wet concrete)								
Temperature range	I: 24 °C / 40 °C	$\tau_{Rk,cr}$	[N/mm ²]	7,0	6,0	6,0	7,0	7,0
	II: 35 °C / 60 °C			7,0	6,0	6,0	7,0	7,0
	III: 50 °C / 72 °C			7,0	6,0	6,0	7,0	7,0
Diamond-drilling (water filled hole)								
Temperature range	I: 24 °C / 40 °C	$\tau_{Rk,cr}$	[N/mm ²]	7,0	6,5	6,0	6,0	6,0
	II: 35 °C / 60 °C			7,0	6,5	6,0	6,0	6,0
	III: 50 °C / 72 °C			7,0	6,0	6,0	6,0	6,0
Installation factors; Diamond-drilling								
Dry or wet concrete		γ_{inst}	[-]	1,0				
Water filled hole				1,2		1,4		

fischer Injection System FIS EM PLUS

Performance

Characteristic resistance to combined pull-out and concrete failure for fischer RG M I; working life 50 years

Annex C8

Appendix 36 / 28

Table C9.1: Characteristic resistance to combined pull-out and concrete failure for metric fischer RG M I in hammer or diamond drilled holes; uncracked or cracked concrete; working life 100 years

fischer RG M I		M8	M10	M12	M16	M20	
Combined pull-out and concrete cone failure							
Calculation diameter	d	[mm]	12	15,7	18	22	28
Uncracked concrete							
Characteristic bond resistance in uncracked concrete C20/25							
<u>Hammer-drilling with standard drill bit or hollow drill bit (dry or wet concrete)</u>							
Temperature range	I: 24 °C / 40 °C	$\tau_{Rk,100,ucr}$ [N/mm ²]	15,4	14,4	14,0	13,3	12,6
	II: 35 °C / 60 °C		11,3	10,5	10,5	9,8	9,0
	III: 50 °C / 72 °C		7,7	7,8	7,8	7,8	7,2
<u>Hammer-drilling with standard drill bit or hollow drill bit (water filled hole)</u>							
Temperature range	I: 24 °C / 40 °C	$\tau_{Rk,100,ucr}$ [N/mm ²]	15,4	13,9	13,0	11,7	10,5
	II: 35 °C / 60 °C		10,5	9,0	9,0	8,3	7,5
	III: 50 °C / 72 °C		7,2	7,2	6,6	6,5	5,9
Installation factors; Hammer-drilling with standard drill bit or hollow drill bit							
Dry or wet concrete	γ_{inst}	[-]	1,0				
Water filled hole			1,4				
<u>Diamond-drilling (dry or wet concrete)</u>							
Temperature range	I: 24 °C / 40 °C	$\tau_{Rk,100,ucr}$ [N/mm ²]	10,9	10,1	9,8	9,2	8,6
	II: 35 °C / 60 °C		9,8	9,0	8,3	7,5	6,8
	III: 50 °C / 72 °C		6,6	6,6	6,0	5,9	5,2
<u>Diamond-drilling (water filled hole)</u>							
Temperature range	I: 24 °C / 40 °C	$\tau_{Rk,100,ucr}$ [N/mm ²]	12,5	11,2	10,3	9,3	8,4
	II: 35 °C / 60 °C		9,8	9,0	8,3	7,5	6,8
	III: 50 °C / 72 °C		6,6	6,6	6,0	5,9	5,2
Installation factors; Diamond-drilling							
Dry or wet concrete	γ_{inst}	[-]	1,0				
Water filled hole			1,4				
Cracked concrete							
Characteristic bond resistance in cracked concrete C20/25							
<u>Hammer-drilling with standard drill bit or hollow drill bit (dry or wet concrete)</u>							
Temperature range	I: 24 °C / 40 °C	$\tau_{Rk,100,cr}$ [N/mm ²]	4,2	5,1	4,8	4,6	4,6
	II: 35 °C / 60 °C		4,2	5,1	4,8	4,6	4,6
	III: 50 °C / 72 °C		4,2	5,1	4,8	4,6	4,6
<u>Hammer-drilling with standard drill bit or hollow drill bit (water filled hole)</u>							
Temperature range	I: 24 °C / 40 °C	$\tau_{Rk,100,cr}$ [N/mm ²]	4,2	5,5	4,8	3,9	3,9
	II: 35 °C / 60 °C		4,2	5,5	4,8	3,9	3,9
	III: 50 °C / 72 °C		4,2	5,1	4,8	3,9	3,9
Installation factors; Hammer-drilling with standard drill bit or hollow drill bit							
Dry or wet concrete	γ_{inst}	[-]	1,0				
Water filled hole			1,2	1,4			
<u>Diamond-drilling (dry or wet concrete)</u>							
Temperature range	I: 24 °C / 40 °C	$\tau_{Rk,100,cr}$ [N/mm ²]	4,2	5,1	4,8	4,6	4,6
	II: 35 °C / 60 °C		4,2	5,1	4,8	4,6	4,6
	III: 50 °C / 72 °C		4,2	5,1	4,8	4,6	4,6
Installation factors; Diamond-drilling							
Dry or wet concrete	γ_{inst}	[-]	1,0				

fischer Injection System FIS EM PLUS

Performance

Characteristic resistance to combined pull-out and concrete failure for fischer RG M I; working life 100 years

Annex C9

Table C10.1: Characteristic resistance to combined pull-out and concrete failure for metric fischer FIS IG in hammer or diamond drilled holes; uncracked or cracked concrete; working life 50 years

fischer FIS IG			M8	M10	M12	M16	M20	
Combined pull-out and concrete cone failure								
Calculation diameter	d	[mm]	12	16	20	24	30	
Uncracked concrete								
Characteristic bond resistance in uncracked concrete C20/25								
Hammer-drilling with standard drill bit or hollow drill bit (dry or wet concrete)								
Temperature range	I: 24 °C / 40 °C	$\tau_{Rk,ucr}$	[N/mm ²]	18,8	17,6	16,7	16,0	15,1
	II: 35 °C / 60 °C			18,0	17,0	16,0	15,0	14,0
	III: 50 °C / 72 °C			17,0	16,0	15,0	14,0	13,0
Hammer-drilling with standard drill bit or hollow drill bit (water filled hole)								
Temperature range	I: 24 °C / 40 °C	$\tau_{Rk,ucr}$	[N/mm ²]	18,8	16,9	15,3	13,8	12,3
	II: 35 °C / 60 °C			15,0	13,0	11,0	10,0	9,0
	III: 50 °C / 72 °C			14,0	12,0	11,0	10,0	9,0
Installation factors; Hammer-drilling with standard drill bit or hollow drill bit								
Dry or wet concrete		γ_{inst}	[-]	1,0				
Water filled hole				1,4				
Diamond-drilling (dry or wet concrete)								
Temperature range	I: 24 °C / 40 °C	$\tau_{Rk,ucr}$	[N/mm ²]	13,5	12,4	11,6	10,9	10,3
	II: 35 °C / 60 °C			13,0	12,0	10,0	10,0	9,0
	III: 50 °C / 72 °C			12,0	11,0	10,0	9,0	8,0
Diamond-drilling (water filled hole)								
Temperature range	I: 24 °C / 40 °C	$\tau_{Rk,ucr}$	[N/mm ²]	15,5	13,6	12,0	10,9	9,9
	II: 35 °C / 60 °C			13,0	12,0	10,0	10,0	9,0
	III: 50 °C / 72 °C			12,0	11,0	10,0	9,0	8,0
Installation factors; Diamond-drilling								
Dry or wet concrete		γ_{inst}	[-]	1,0				
Water filled hole				1,4				
Cracked concrete								
Characteristic bond resistance in cracked concrete C20/25								
Hammer-drilling with standard drill bit or hollow drill bit (dry or wet concrete)								
Temperature range	I: 24 °C / 40 °C	$\tau_{Rk,cr}$	[N/mm ²]	10,1	9,5	8,5	8,5	8,5
	II: 35 °C / 60 °C			10,1	9,5	8,5	8,5	8,5
	III: 50 °C / 72 °C			9,5	8,9	8,5	8,5	8,5
Hammer-drilling with standard drill bit or hollow drill bit (water filled hole)								
Temperature range	I: 24 °C / 40 °C	$\tau_{Rk,cr}$	[N/mm ²]	8,7	7,7	6,0	6,0	6,0
	II: 35 °C / 60 °C			8,7	7,7	6,0	6,0	6,0
	III: 50 °C / 72 °C			8,1	7,3	6,0	6,0	6,0
Installation factors; Hammer-drilling with standard drill bit or hollow drill bit								
Dry or wet concrete		γ_{inst}	[-]	1,0				
Water filled hole				1,2		1,4		
Diamond-drilling (dry or wet concrete)								
Temperature range	I: 24 °C / 40 °C	$\tau_{Rk,cr}$	[N/mm ²]	7,0	6,0	6,0	7,0	7,0
	II: 35 °C / 60 °C			7,0	6,0	6,0	7,0	7,0
	III: 50 °C / 72 °C			7,0	6,0	6,0	7,0	7,0
Diamond-drilling (water filled hole)								
Temperature range	I: 24 °C / 40 °C	$\tau_{Rk,cr}$	[N/mm ²]	7,5	6,0	6,0	6,0	6,0
	II: 35 °C / 60 °C			7,5	6,0	6,0	6,0	6,0
	III: 50 °C / 72 °C			7,0	6,0	6,0	6,0	6,0
Installation factors; Diamond-drilling								
Dry or wet concrete		γ_{inst}	[-]	1,0				
Water filled hole				1,2		1,4		

fischer Injection System FIS EM PLUS

Performance

Characteristic resistance to combined pull-out and concrete failure for fischer FIS IG; working life 50 years

Annex C10

Appendix 38 / 28

Table C11.1: Characteristic resistance to combined pull-out and concrete failure for metric fischer FIS IG in hammer or diamond drilled holes; uncracked or cracked concrete; working life 100 years

fischer FIS IG		M8	M10	M12	M16	M20	
Combined pull-out and concrete cone failure							
Calculation diameter	d	[mm]	12	16	20	24	30
Uncracked concrete							
Characteristic bond resistance in uncracked concrete C20/25							
<u>Hammer-drilling with standard drill bit or hollow drill bit (dry or wet concrete)</u>							
Temperature range	I: 24 °C / 40 °C	$\tau_{Rk,100,ucr}$ [N/mm ²]	15,4	14,4	13,7	13,1	12,4
	II: 35 °C / 60 °C		13,5	12,8	12,0	11,3	10,5
	III: 50 °C / 72 °C		10,2	10,4	9,8	9,1	8,5
<u>Hammer-drilling with standard drill bit or hollow drill bit (water filled hole)</u>							
Temperature range	I: 24 °C / 40 °C	$\tau_{Rk,100,ucr}$ [N/mm ²]	15,4	13,9	12,5	11,3	10,1
	II: 35 °C / 60 °C		11,3	9,8	8,3	7,5	6,8
	III: 50 °C / 72 °C		8,4	7,8	7,2	6,5	5,9
Installation factors; Hammer-drilling with standard drill bit or hollow drill bit							
Dry or wet concrete	γ_{inst}	[-]	1,0				
Water filled hole			1,4				
<u>Diamond-drilling (dry or wet concrete)</u>							
Temperature range	I: 24 °C / 40 °C	$\tau_{Rk,100,ucr}$ [N/mm ²]	11,6	10,5	10,1	9,3	8,8
	II: 35 °C / 60 °C		9,8	9,0	7,5	7,5	6,8
	III: 50 °C / 72 °C		7,2	7,2	6,5	5,9	5,2
<u>Diamond-drilling (water filled hole)</u>							
Temperature range	I: 24 °C / 40 °C	$\tau_{Rk,100,ucr}$ [N/mm ²]	11,6	11,2	10,0	8,9	8,1
	II: 35 °C / 60 °C		9,8	9,0	7,5	7,5	6,8
	III: 50 °C / 72 °C		7,2	7,2	6,5	5,9	5,2
Installation factors; Diamond-drilling							
Dry or wet concrete	γ_{inst}	[-]	1,0				
Water filled hole			1,4				
Cracked concrete							
Characteristic bond resistance in cracked concrete C20/25							
<u>Hammer-drilling with standard drill bit or hollow drill bit (dry or wet concrete)</u>							
Temperature range	I: 24 °C / 40 °C	$\tau_{Rk,100,cr}$ [N/mm ²]	7,6	7,2	6,9	6,7	6,3
	II: 35 °C / 60 °C		7,6	7,2	6,9	6,7	6,3
	III: 50 °C / 72 °C		7,2	6,8	6,4	6,3	6,0
<u>Hammer-drilling with standard drill bit or hollow drill bit (water filled hole)</u>							
Temperature range	I: 24 °C / 40 °C	$\tau_{Rk,100,cr}$ [N/mm ²]	6,5	5,9	4,9	4,7	4,4
	II: 35 °C / 60 °C		6,5	5,9	4,9	4,7	4,4
	III: 50 °C / 72 °C		6,1	5,5	4,5	4,4	4,3
Installation factors; Hammer-drilling with standard drill bit or hollow drill bit							
Dry or wet concrete	γ_{inst}	[-]	1,0				
Water filled hole			1,2	1,4			
<u>Diamond-drilling (dry or wet concrete)</u>							
Temperature range	I: 24 °C / 40 °C	$\tau_{Rk,100,cr}$ [N/mm ²]	5,6	3,9	3,9	4,6	4,6
	II: 35 °C / 60 °C		5,6	3,9	3,9	4,6	4,6
	III: 50 °C / 72 °C		5,6	3,9	3,9	4,6	4,6
Installation factors; Diamond-drilling							
Dry or wet concrete	γ_{inst}	[-]	1,0				

fischer Injection System FIS EM PLUS

Performance

Characteristic resistance to combined pull-out and concrete failure for fischer FIS IG; working life 100 years

Annex C11

Appendix 39 / 28

Table C12.1: Characteristic resistance to combined pull-out and concrete failure for metric reinforcing bars in hammer or diamond drilled holes; uncracked concrete; working life 50 years

Nominal diameter of the bar		ϕ	8 ¹⁾	10	12	14	16	18	20	22	24		
Combined pull-out and concrete cone failure													
Calculation diameter		d	[mm]	8	10	12	14	16	18	20	22	24	
Uncracked concrete													
Characteristic bond resistance in uncracked concrete C20/25													
Hammer-drilling with standard drill bit or hollow drill bit (dry or wet concrete)													
Temperature range	I: 24 °C / 40 °C	$\tau_{Rk,ucr}$	[N/mm ²]	16,0	16,8	16,1	15,5	15,0	14,6	14,2	14,0	13,6	
	II: 35 °C / 60 °C			16,0	15,0	15,0	14,0	14,0	13,0	13,0	13,0	13,0	12,0
	III: 50 °C / 72 °C			15,0	14,0	14,0	13,0	13,0	12,0	12,0	12,0	12,0	12,0
Hammer-drilling with standard drill bit or hollow drill bit (water filled hole)													
Temperature range	I: 24 °C / 40 °C	$\tau_{Rk,ucr}$	[N/mm ²]	16,0	16,8	16,1	14,9	14,4	13,4	13,0	12,1	11,8	
	II: 35 °C / 60 °C			16,0	16,0	14,0	13,0	12,0	12,0	11,0	11,0	10,0	
	III: 50 °C / 72 °C			15,0	14,0	13,0	12,0	12,0	11,0	11,0	10,0	10,0	
Installation factors; Hammer-drilling with standard drill bit or hollow drill bit													
Dry or wet concrete		γ_{inst}	[-]	1,0									
Water filled hole				1,4									
Diamond-drilling (dry or wet concrete as well as water filled hole)													
Temperature range	I: 24 °C / 40 °C	$\tau_{Rk,ucr}$	[N/mm ²]	16,0	15,0	13,0	12,0	12,0	11,0	10,0	10,0	10,0	
	II: 35 °C / 60 °C			16,0	15,0	13,0	12,0	12,0	11,0	10,0	10,0	10,0	
	III: 50 °C / 72 °C			15,0	14,0	12,0	11,0	11,0	10,0	10,0	9,0	9,0	
Installation factors; Diamond-drilling													
Dry or wet concrete		γ_{inst}	[-]	1,0									
Water filled hole				1,4									
Nominal diameter of the bar		ϕ	25	26	28	30 ¹⁾	32 ¹⁾	34 ¹⁾	36 ¹⁾	40 ¹⁾			
Combined pull-out and concrete cone failure													
Calculation diameter		d	[mm]	25	26	28	30	32	34	36	40		
Uncracked concrete													
Characteristic bond resistance in uncracked concrete C20/25													
Hammer-drilling with standard drill bit or hollow drill bit (dry or wet concrete)													
Temperature range	I: 24 °C / 40 °C	$\tau_{Rk,ucr}$	[N/mm ²]	13,5	13,3	13,1	12,9	12,7	12,5	12,4	12,1		
	II: 35 °C / 60 °C			12,0	12,0	12,0	12,0	12,0	11,0	11,0	11,0		
	III: 50 °C / 72 °C			11,0	11,0	11,0	11,0	11,0	11,0	10,0	10,0		
Hammer-drilling with standard drill bit or hollow drill bit (water filled hole)													
Temperature range	I: 24 °C / 40 °C	$\tau_{Rk,ucr}$	[N/mm ²]	11,5	11,4	10,6	10,5	10,3	9,0	8,0	8,0		
	II: 35 °C / 60 °C			10,0	10,0	10,0	9,0	9,0	9,0	8,0	8,0		
	III: 50 °C / 72 °C			9,0	9,0	9,0	9,0	8,0	8,0	8,0	8,0		
Installation factors; Hammer-drilling with standard drill bit or hollow drill bit													
Dry or wet concrete		γ_{inst}	[-]	1,0									
Water filled hole				1,4									
Diamond-drilling (dry or wet concrete as well as water filled hole)													
Temperature range	I: 24 °C / 40 °C	$\tau_{Rk,ucr}$	[N/mm ²]	9,0	9,0	9,0	9,0	8,0	8,0	8,0	7,0		
	II: 35 °C / 60 °C			9,0	9,0	9,0	9,0	8,0	8,0	8,0	8,0		
	III: 50 °C / 72 °C			9,0	8,0	8,0	8,0	8,0	7,0	7,0	7,0		
Installation factors; Diamond-drilling													
Dry or wet concrete		γ_{inst}	[-]	1,0									
Water filled hole				1,4									

¹⁾ Not allowed for hollow drill bit.

fischer Injection System FIS EM PLUS

Performance

Characteristic resistance to combined pull-out and concrete failure for reinforcing bars; working life 50 years

Annex C12

Appendix 40 / 28

Table C13.1: Characteristic resistance to combined pull-out and concrete failure for metric reinforcing bars in hammer or diamond drilled holes; cracked concrete; working life 50 years part 1

Nominal diameter of the bar		ϕ	8 ¹⁾	10	12	14	16	18	20	22	24		
Combined pull-out and concrete cone failure													
Calculation diameter		d	[mm]	8	10	12	14	16	18	20	22	24	
Cracked concrete													
Characteristic bond resistance in cracked concrete C20/25													
<u>Hammer-drilling with standard drill bit or hollow drill bit (dry or wet concrete)</u>													
Tem- perature range	I: 24 °C / 40 °C		$\tau_{RK,cr}$	[N/mm ²]	7,0	7,0	8,0	8,0	8,0	8,0	8,0	8,0	
	II: 35 °C / 60 °C				7,0	7,0	8,0	8,0	8,0	8,0	8,0	8,0	8,0
	III: 50 °C / 72 °C				7,0	7,0	8,0	8,0	8,0	8,0	8,0	8,0	8,0
<u>Hammer-drilling with standard drill bit or hollow drill bit (water filled hole)</u>													
Tem- perature range	I: 24 °C / 40 °C		$\tau_{RK,cr}$	[N/mm ²]	6,0	7,5	6,5	6,5	6,5	6,0	6,0	6,0	
	II: 35 °C / 60 °C				6,0	7,5	6,5	6,5	6,5	6,0	6,0	6,0	6,0
	III: 50 °C / 72 °C				6,0	6,5	6,5	6,0	6,0	6,0	6,0	6,0	6,0
Installation factors; Hammer-drilling with standard drill bit or hollow drill bit													
Dry or wet concrete		γ_{inst}	[-]	1,0									
Water filled hole				1,2					1,4				
<u>Diamond-drilling (dry or wet concrete)</u>													
Tem- perature range	I: 24 °C / 40 °C		$\tau_{RK,cr}$	[N/mm ²]	7,0	7,0	7,0	7,0	6,0	6,0	6,0	7,0	
	II: 35 °C / 60 °C				7,0	7,0	7,0	7,0	6,0	6,0	6,0	7,0	7,0
	III: 50 °C / 72 °C				7,0	7,0	7,0	7,0	6,0	6,0	6,0	7,0	7,0
<u>Diamond-drilling (water filled hole)</u>													
Tem- perature range	I: 24 °C / 40 °C		$\tau_{RK,cr}$	[N/mm ²]	6,0	7,5	6,5	6,5	6,5	6,0	6,0	6,0	
	II: 35 °C / 60 °C				6,0	7,5	6,5	6,5	6,5	6,0	6,0	6,0	6,0
	III: 50 °C / 72 °C				6,0	6,5	6,5	6,0	6,0	6,0	6,0	6,0	6,0
Installation factors; Diamond-drilling													
Dry or wet concrete		γ_{inst}	[-]	1,0									
Water filled hole				1,2					1,4				

¹⁾ Not allowed for hollow drill bit.

fischer Injection System FIS EM PLUS

Performance

Characteristic resistance to combined pull-out and concrete failure for reinforcing bars; working life 50 years part 1

Annex C13

Appendix 41 / 28

Table C14.1: Characteristic resistance to combined pull-out and concrete failure for metric reinforcing bars in hammer or diamond drilled holes; cracked concrete; working life 50 years part 2

Nominal diameter of the bar		ϕ	25	26	28	30 ¹⁾	32 ¹⁾	34 ¹⁾	36 ¹⁾	40 ¹⁾		
Combined pull-out and concrete cone failure												
Calculation diameter	d	[mm]	25	26	28	30	32	34	36	40		
Cracked concrete												
Characteristic bond resistance in cracked concrete C20/25												
Hammer-drilling with standard drill bit or hollow drill bit (dry or wet concrete)												
Tem- perature range	I: 24 °C / 40 °C		$\tau_{Rk,cr}$	[N/mm ²]	8,0	8,0	8,0	8,0	8,0	8,0	8,0	
	II: 35 °C / 60 °C				8,0	8,0	8,0	8,0	8,0	8,0	8,0	8,0
	III: 50 °C / 72 °C				8,0	8,0	8,0	8,0	8,0	8,0	8,0	8,0
Hammer-drilling with standard drill bit or hollow drill bit (water filled hole)												
Tem- perature range	I: 24 °C / 40 °C		$\tau_{Rk,cr}$	[N/mm ²]	6,0	6,0	6,0	6,0	5,0	5,0	5,0	
	II: 35 °C / 60 °C				6,0	6,0	6,0	6,0	5,0	5,0	5,0	5,0
	III: 50 °C / 72 °C				6,0	6,0	6,0	6,0	5,0	5,0	5,0	5,0
Installation factors; Hammer-drilling with standard drill bit or hollow drill bit												
Dry or wet concrete		γ_{inst}	[-]	1,0								
Water filled hole				1,4								
Diamond-drilling (dry or wet concrete)												
Tem- perature range	I: 24 °C / 40 °C		$\tau_{Rk,cr}$	[N/mm ²]	7,0	7,0	7,0	7,0	5,0	5,0	5,0	
	II: 35 °C / 60 °C				7,0	7,0	7,0	7,0	5,0	5,0	5,0	5,0
	III: 50 °C / 72 °C				7,0	7,0	7,0	7,0	5,0	5,0	5,0	5,0
Diamond-drilling (water filled hole)												
Tem- perature range	I: 24 °C / 40 °C		$\tau_{Rk,cr}$	[N/mm ²]	6,0	6,0	6,0	6,0	5,0	5,0	5,0	
	II: 35 °C / 60 °C				6,0	6,0	6,0	6,0	5,0	5,0	5,0	5,0
	III: 50 °C / 72 °C				6,0	6,0	6,0	6,0	5,0	5,0	5,0	5,0
Installation factors; Diamond-drilling												
Dry or wet concrete		γ_{inst}	[-]	1,0								
Water filled hole				1,4								

¹⁾ Not allowed for hollow drill bit.

fischer Injection System FIS EM PLUS

Performance

Characteristic resistance to combined pull-out and concrete failure for reinforcing bars; working life 50 years part 2

Annex C14

Appendix 42 / 28

Table C15.1: Characteristic resistance to combined pull-out and concrete failure for metric reinforcing bars in hammer or diamond drilled holes; uncracked concrete; working life 100 years

Nominal diameter of the bar		ϕ	8 ¹⁾	10	12	14	16	18	20	22	24		
Combined pull-out and concrete cone failure													
Calculation diameter		d	[mm]	8	10	12	14	16	18	20	22	24	
Uncracked concrete													
Characteristic bond resistance in uncracked concrete C20/25													
Hammer-drilling with standard drill bit or hollow drill bit (dry or wet concrete)													
Temperature range	I: 24 °C / 40 °C	$\tau_{RK,100,ucr}$	[N/mm ²]	12,0	13,8	13,2	12,7	12,3	12,0	11,6	11,5	11,2	
	II: 35 °C / 60 °C			12,0	11,3	11,3	10,5	10,5	9,8	9,8	9,8	9,8	9,0
	III: 50 °C / 72 °C			8,3	8,4	8,4	8,5	8,5	7,8	7,8	7,8	7,8	7,8
Hammer-drilling with standard drill bit or hollow drill bit (water filled hole)													
Temperature range	I: 24 °C / 40 °C	$\tau_{RK,100,ucr}$	[N/mm ²]	12,0	13,8	13,2	12,2	11,8	11,0	10,7	9,9	9,7	
	II: 35 °C / 60 °C			12,0	12,0	10,5	9,8	9,0	9,0	8,3	8,3	7,5	
	III: 50 °C / 72 °C			8,3	8,4	7,8	7,8	7,8	7,2	7,2	6,5	6,5	
Installation factors; Hammer-drilling with standard drill bit or hollow drill bit													
Dry or wet concrete		γ_{inst}	[-]	1,0									
Water filled hole				1,4									
Diamond-drilling (dry or wet concrete as well as water filled hole)													
Temperature range	I: 24 °C / 40 °C	$\tau_{RK,100,ucr}$	[N/mm ²]	12,0	11,3	9,8	9,0	9,0	8,3	7,5	7,5	7,5	
	II: 35 °C / 60 °C			12,0	11,3	9,8	9,0	9,0	8,3	7,5	7,5	7,5	
	III: 50 °C / 72 °C			8,3	8,4	7,2	7,2	7,2	6,5	6,5	5,9	5,9	
Installation factors; Diamond-drilling													
Dry or wet concrete		γ_{inst}	[-]	1,0									
Water filled hole				1,4									
Nominal diameter of the bar		ϕ	25	26	28	30 ¹⁾	32 ¹⁾	34 ¹⁾	36 ¹⁾	40 ¹⁾			
Combined pull-out and concrete cone failure													
Calculation diameter		d	[mm]	25	26	28	30	32	34	36	40		
Uncracked concrete													
Characteristic bond resistance in uncracked concrete C20/25													
Hammer-drilling with standard drill bit or hollow drill bit (dry or wet concrete)													
Temperature range	I: 24 °C / 40 °C	$\tau_{RK,100,ucr}$	[N/mm ²]	11,1	10,9	10,8	10,6	10,5	10,3	10,1	9,9		
	II: 35 °C / 60 °C			9,0	9,0	9,0	9,0	9,0	8,3	8,3	8,3		
	III: 50 °C / 72 °C			7,2	7,2	7,2	7,2	7,2	7,2	6,5	6,5		
Hammer-drilling with standard drill bit or hollow drill bit (water filled hole)													
Temperature range	I: 24 °C / 40 °C	$\tau_{RK,100,ucr}$	[N/mm ²]	9,4	9,3	8,7	8,6	8,5	6,8	6,0	6,0		
	II: 35 °C / 60 °C			7,5	7,5	7,5	6,8	6,8	6,8	6,0	6,0		
	III: 50 °C / 72 °C			5,9	5,9	5,9	5,9	5,2	5,2	5,2	5,2		
Installation factors; Hammer-drilling with standard drill bit or hollow drill bit													
Dry or wet concrete		γ_{inst}	[-]	1,0									
Water filled hole				1,4									
Diamond-drilling (dry or wet concrete as well as water filled hole)													
Temperature range	I: 24 °C / 40 °C	$\tau_{RK,100,ucr}$	[N/mm ²]	6,8	6,8	6,8	6,8	6,0	6,0	6,0	5,3		
	II: 35 °C / 60 °C			6,8	6,8	6,8	6,8	6,0	6,0	6,0	6,0	5,3	
	III: 50 °C / 72 °C			5,9	5,2	5,2	5,2	5,2	4,6	4,6	4,6		
Installation factors; Diamond-drilling													
Dry or wet concrete		γ_{inst}	[-]	1,0									
Water filled hole				1,4									

¹⁾ Not allowed for hollow drill bit.

fischer Injection System FIS EM PLUS

Performance

Characteristic resistance to combined pull-out and concrete failure for reinforcing bars; working life 100 years

Annex C15

Appendix 43 / 28

Table C16.1: Characteristic resistance to combined pull-out and concrete failure for metric reinforcing bars in hammer or diamond drilled holes; cracked concrete; working life 100 years

Nominal diameter of the bar		ϕ	8 ¹⁾	10	12	14	16	18	20	22	24		
Combined pull-out and concrete cone failure													
Calculation diameter		d	[mm]	8	10	12	14	16	18	20	22	24	
Cracked concrete													
Characteristic bond resistance in cracked concrete C20/25													
Hammer-drilling with standard drill bit or hollow drill bit (dry or wet concrete)													
Temperature range	I: 24 °C / 40 °C	$\tau_{Rk,100,cr}$	[N/mm ²]	4,2	6,0	6,4	5,2	5,2	5,2	5,2	5,2	5,2	
	II: 35 °C / 60 °C			4,2	6,0	6,4	5,2	5,2	5,2	5,2	5,2	5,2	5,2
	III: 50 °C / 72 °C			4,2	6,0	6,4	5,2	5,2	5,2	5,2	5,2	5,2	5,2
Hammer-drilling with standard drill bit or hollow drill bit (water filled hole)													
Temperature range	I: 24 °C / 40 °C	$\tau_{Rk,100,cr}$	[N/mm ²]	3,6	6,4	5,2	4,2	4,2	3,9	3,9	3,9	3,9	
	II: 35 °C / 60 °C			3,6	6,4	5,2	4,2	4,2	3,9	3,9	3,9	3,9	
	III: 50 °C / 72 °C			3,6	5,5	5,2	3,9	3,9	3,9	3,9	3,9	3,9	
Installation factors; Hammer-drilling with standard drill bit or hollow drill bit													
Dry or wet concrete		γ_{inst}	[-]	1,0									
Water filled hole				1,2				1,4					
Diamond-drilling (dry or wet concrete)													
Temperature range	I: 24 °C / 40 °C	$\tau_{Rk,100,cr}$	[N/mm ²]	4,2	6,0	5,6	4,6	3,9	3,9	3,9	4,6	4,6	
	II: 35 °C / 60 °C			4,2	6,0	5,6	4,6	3,9	3,9	3,9	4,6	4,6	
	III: 50 °C / 72 °C			4,2	6,0	5,6	4,6	3,9	3,9	3,9	4,6	4,6	
Installation factor; Diamond-drilling													
Dry or wet concrete		γ_{inst}	[-]	1,0									
Nominal diameter of the bar		ϕ		25	26	28	30 ¹⁾	32 ¹⁾	34 ¹⁾	36 ¹⁾	40 ¹⁾		
Combined pull-out and concrete cone failure													
Calculation diameter		d	[mm]	25	26	28	30	32	34	36	40		
Cracked concrete													
Characteristic bond resistance in cracked concrete C20/25													
Hammer-drilling with standard drill bit or hollow drill bit (dry or wet concrete)													
Temperature range	I: 24 °C / 40 °C	$\tau_{Rk,100,cr}$	[N/mm ²]	5,2	5,2	5,2	5,2	5,2	5,2	5,2	5,2	5,2	
	II: 35 °C / 60 °C			5,2	5,2	5,2	5,2	5,2	5,2	5,2	5,2	5,2	
	III: 50 °C / 72 °C			5,2	5,2	5,2	5,2	5,2	5,2	5,2	5,2	5,2	
Hammer-drilling with standard drill bit or hollow drill bit (water filled hole)													
Temperature range	I: 24 °C / 40 °C	$\tau_{Rk,100,cr}$	[N/mm ²]	3,9	3,9	3,9	3,9	3,3	3,8	3,8	3,8		
	II: 35 °C / 60 °C			3,9	3,9	3,9	3,9	3,3	3,8	3,8	3,8		
	III: 50 °C / 72 °C			3,9	3,9	3,9	3,9	3,3	3,3	3,3	3,3		
Installation factors; Hammer-drilling with standard drill bit or hollow drill bit													
Dry or wet concrete		γ_{inst}	[-]	1,0									
Water filled hole				1,4				1,4					
Diamond-drilling (dry or wet concrete)													
Temperature range	I: 24 °C / 40 °C	$\tau_{Rk,100,cr}$	[N/mm ²]	4,6	4,6	4,6	4,6	3,3	3,3	3,3	3,3		
	II: 35 °C / 60 °C			4,6	4,6	4,6	4,6	3,3	3,3	3,3	3,3		
	III: 50 °C / 72 °C			4,6	4,6	4,6	4,6	3,3	3,3	3,3	3,3		
Installation factor; Diamond-drilling													
Dry or wet concrete		γ_{inst}	[-]	1,0									

¹⁾ Not allowed for hollow drill bit.

fischer Injection System FIS EM PLUS

Performance

Characteristic resistance for combined pull-out and concrete failure for reinforcing bars; working life 100 years

Annex C16

Appendix 44 / 28

Table C17.1: Characteristic resistance to combined pull-out and concrete failure for metric fischer FRA in hammer or diamond drilled holes; uncracked concrete; working life 50 years

fischer FRA		M12	M16	M20	M24	
Combined pull-out and concrete cone failure						
Calculation diameter	d [mm]	12	16	20	25	
Uncracked concrete						
Characteristic bond resistance in uncracked concrete C20/25						
Hammer-drilling with standard drill bit or hollow drill bit (dry or wet concrete)						
Temperature range	I: 24 °C / 40 °C	$\tau_{Rk,ucr}$ [N/mm ²]	16,1	15,0	14,2	13,5
	II: 35 °C / 60 °C		15,0	14,0	13,0	12,0
	III: 50 °C / 72 °C		14,0	13,0	12,0	11,0
Hammer-drilling with standard drill bit or hollow drill bit (water filled hole)						
Temperature range	I: 24 °C / 40 °C	$\tau_{Rk,ucr}$ [N/mm ²]	16,1	14,4	13,0	11,5
	II: 35 °C / 60 °C		14,0	12,0	11,0	10,0
	III: 50 °C / 72 °C		13,0	12,0	11,0	9,0
Installation factors; Hammer-drilling with standard drill bit or hollow drill bit						
Dry or wet concrete		γ_{inst} [-]	1,0			
Water filled hole			1,4			
Diamond-drilling (dry or wet concrete as well as water filled hole)						
Temperature range	I: 24 °C / 40 °C	$\tau_{Rk,ucr}$ [N/mm ²]	13,0	12,0	10,0	9,0
	II: 35 °C / 60 °C		13,0	12,0	10,0	9,0
	III: 50 °C / 72 °C		12,0	11,0	10,0	9,0
Installation factors; Diamond-drilling						
Dry or wet concrete		γ_{inst} [-]	1,0			
Water filled hole			1,4			

fischer Injection System FIS EM PLUS

Performance

Characteristic resistance to combined pull-out and concrete failure for fischer FRA; working life 50 years

Annex C17

Appendix 45 / 28

Table C18.1: Characteristic resistance to combined pull-out and concrete failure for metric fischer FRA in hammer or diamond drilled holes; cracked concrete; working life 50 years

fischer FRA		M12	M16	M20	M24	
Combined pull-out and concrete cone failure						
Calculation diameter	d [mm]	12	16	20	25	
Cracked concrete						
Characteristic bond resistance in cracked concrete C20/25						
Hammer-drilling with standard drill bit or hollow drill bit (dry or wet concrete)						
Temperature range	I: 24 °C / 40 °C	$\tau_{Rk,cr}$ [N/mm ²]	8,0	8,0	8,0	8,0
	II: 35 °C / 60 °C		8,0	8,0	8,0	8,0
	III: 50 °C / 72 °C		8,0	8,0	8,0	8,0
Hammer-drilling with standard drill bit or hollow drill bit (water filled hole)						
Temperature range	I: 24 °C / 40 °C	$\tau_{Rk,cr}$ [N/mm ²]	6,5	6,5	6,0	6,0
	II: 35 °C / 60 °C		6,5	6,5	6,0	6,0
	III: 50 °C / 72 °C		6,5	6,0	6,0	6,0
Installation factors; Hammer-drilling with standard drill bit or hollow drill bit						
Dry or wet concrete	γ_{inst} [-]	[-]	1,0			
Water filled hole			1,2	1,4		
Diamond-drilling (dry or wet concrete)						
Temperature range	I: 24 °C / 40 °C	$\tau_{Rk,cr}$ [N/mm ²]	7,0	6,0	6,0	7,0
	II: 35 °C / 60 °C		7,0	6,0	6,0	7,0
	III: 50 °C / 72 °C		7,0	6,0	6,0	7,0
Diamond-drilling (water filled hole)						
Temperature range	I: 24 °C / 40 °C	$\tau_{Rk,cr}$ [N/mm ²]	6,5	6,5	6,0	6,0
	II: 35 °C / 60 °C		6,5	6,5	6,0	6,0
	III: 50 °C / 72 °C		6,5	6,0	6,0	6,0
Installation factors; Diamond-drilling						
Dry or wet concrete	γ_{inst} [-]	[-]	1,0			
Water filled hole			1,2	1,4		

fischer Injection System FIS EM PLUS

Performance

Characteristic resistance to combined pull-out and concrete failure for fischer FRA; working life 50 years

Annex C18

Appendix 46 / 28

Table C19.1: Characteristic resistance to combined pull-out and concrete failure for metric fischer FRA in hammer or diamond drilled holes; uncracked or cracked concrete; working life 100 years

fischer FRA			M12	M16	M20	M24	
Combined pull-out and concrete cone failure							
Calculation diameter	d	[mm]	12	16	20	25	
Uncracked concrete							
Characteristic bond resistance in uncracked concrete C20/25							
Hammer-drilling with standard drill bit or hollow drill bit (dry or wet concrete)							
Temperature range	I: 24 °C / 40 °C	$\tau_{Rk,100,ucr}$	[N/mm ²]	13,2	12,3	11,6	11,1
	II: 35 °C / 60 °C			11,3	10,5	9,8	9,0
	III: 50 °C / 72 °C			8,4	8,5	7,8	7,2
Hammer-drilling with standard drill bit or hollow drill bit (water filled hole)							
Temperature range	I: 24 °C / 40 °C	$\tau_{Rk,100,ucr}$	[N/mm ²]	13,2	11,8	10,7	9,4
	II: 35 °C / 60 °C			10,5	9,0	8,3	7,5
	III: 50 °C / 72 °C			7,8	7,8	7,2	5,9
Installation factors; Hammer-drilling with standard drill bit or hollow drill bit							
Dry or wet concrete		γ_{inst}	[-]	1,0			
Water filled hole				1,4			
Diamond-drilling (dry or wet concrete as well as water filled hole)							
Temperature range	I: 24 °C / 40 °C	$\tau_{Rk,100,ucr}$	[N/mm ²]	9,8	9,0	7,5	6,8
	II: 35 °C / 60 °C			9,8	9,0	7,5	6,8
	III: 50 °C / 72 °C			7,2	7,2	6,5	5,9
Installation factors; Diamond-drilling							
Dry or wet concrete		γ_{inst}	[-]	1,0			
Water filled hole				1,4			
fischer FRA			M12	M16	M20	M24	
Combined pull-out and concrete cone failure							
Calculation diameter	d	[mm]	12	16	20	25	
Cracked concrete							
Characteristic bond resistance in cracked concrete C20/25							
Hammer-drilling with standard drill bit or hollow drill bit (dry or wet concrete)							
Temperature range	I: 24 °C / 40 °C	$\tau_{Rk,100,cr}$	[N/mm ²]	6,4	5,2	5,2	5,2
	II: 35 °C / 60 °C			6,4	5,2	5,2	5,2
	III: 50 °C / 72 °C			6,4	5,2	5,2	5,2
Hammer-drilling with standard drill bit or hollow drill bit (water filled hole)							
Temperature range	I: 24 °C / 40 °C	$\tau_{Rk,100,cr}$	[N/mm ²]	5,2	4,2	3,9	3,9
	II: 35 °C / 60 °C			5,2	4,2	3,9	3,9
	III: 50 °C / 72 °C			5,2	3,9	3,9	3,9
Installation factors; Hammer-drilling with standard drill bit or hollow drill bit							
Dry or wet concrete		γ_{inst}	[-]	1,0			
Water filled hole				1,2	1,4		
Diamond-drilling (dry or wet concrete)							
Temperature range	I: 24 °C / 40 °C	$\tau_{Rk,100,cr}$	[N/mm ²]	5,6	3,9	3,9	4,6
	II: 35 °C / 60 °C			5,6	3,9	3,9	4,6
	III: 50 °C / 72 °C			5,6	3,9	3,9	4,6
Installation factors; Diamond-drilling							
Dry or wet concrete		γ_{inst}	[-]	1,0			

fischer Injection System FIS EM PLUS

Performance

Characteristic resistance to combined pull-out and concrete failure for fischer FRA; working life 100 years

Annex C19

Appendix 47 / 28

Table C20.1: Displacements for metric Anchor rods / Threaded rods and metric fischer FIS IG

Anchor rod / Threaded rod	M8	M10	M12	M14	M16	M20	M22	M24	M27	M30	
fischer FIS IG	-	-	M8	-	M10	M12	-	M16	-	M20	
Displacement-Factors for tension loading ¹⁾											
Uncracked or cracked concrete; Temperature range I, II, III											
δ_{N0} -Factor	[mm/(N/mm ²)]	0,07	0,08	0,09	0,09	0,10	0,11	0,11	0,12	0,12	0,13
$\delta_{N\infty}$ -Factor		0,11	0,12	0,13	0,14	0,15	0,16	0,17	0,18	0,19	0,19
Displacement-Factors for shear loading ²⁾											
Uncracked or cracked concrete; Temperature range I, II, III											
δ_{V0} -Factor	[mm/kN]	0,18	0,15	0,12	0,10	0,09	0,07	0,07	0,06	0,05	0,05
$\delta_{V\infty}$ -Factor		0,27	0,22	0,18	0,16	0,14	0,11	0,10	0,09	0,08	0,07

1) Calculation of effective displacement:

$$\delta_{N0} = \delta_{N0\text{-Factor}} \cdot \tau$$

$$\delta_{N\infty} = \delta_{N\infty\text{-Factor}} \cdot \tau$$

τ = acting bond strength under tension loading

2) Calculation of effective displacement:

$$\delta_{V0} = \delta_{V0\text{-Factor}} \cdot V$$

$$\delta_{V\infty} = \delta_{V\infty\text{-Factor}} \cdot V$$

V = acting shear loading

Table C20.2: Displacements for metric fischer RG M I

fischer RG M I	M8	M10	M12	M16	M20	
Displacement-Factors for tension loading ¹⁾						
Uncracked or cracked concrete; Temperature range I, II, III						
δ_{N0} -Factor	[mm/(N/mm ²)]	0,09	0,10	0,10	0,11	0,13
$\delta_{N\infty}$ -Factor		0,13	0,15	0,16	0,17	0,19
Displacement-Factors for shear loading ²⁾						
Uncracked or cracked concrete; Temperature range I, II, III						
δ_{V0} -Factor	[mm/kN]	0,12	0,09	0,08	0,07	0,05
$\delta_{V\infty}$ -Factor		0,18	0,14	0,12	0,10	0,08

1) Calculation of effective displacement:

$$\delta_{N0} = \delta_{N0\text{-Factor}} \cdot \tau$$

$$\delta_{N\infty} = \delta_{N\infty\text{-Factor}} \cdot \tau$$

τ = acting bond strength under tension loading

2) Calculation of effective displacement:

$$\delta_{V0} = \delta_{V0\text{-Factor}} \cdot V$$

$$\delta_{V\infty} = \delta_{V\infty\text{-Factor}} \cdot V$$

V = acting shear loading

fischer Injection System FIS EM PLUS

Performance

Displacements for metric Anchor rods / Threaded rods and fischer RG M I / FIS IG

Annex C20

Appendix 48 / 28

Table C21.1: Displacements for metric reinforcing bars

Nominal diameter of the bar	ϕ	8	10	12	14	16	18	20	22	24	25	26	28	30	32	34	36	40
Displacement-Factors for tension loading ¹⁾																		
Uncracked or cracked concrete; Temperature range I, II, III																		
δ_{N0} -Factor	[mm/(N/mm ²)]	0,07	0,08	0,09	0,09	0,10	0,10	0,11	0,11	0,12	0,12	0,12	0,13	0,13	0,13	0,14	0,14	0,15
$\delta_{N\infty}$ -Factor		0,11	0,12	0,13	0,14	0,15	0,16	0,16	0,17	0,18	0,18	0,18	0,19	0,19	0,20	0,20	0,21	0,22
Displacement-Factors for shear loading ²⁾																		
Uncracked or cracked concrete; Temperature range I, II, III																		
δ_{V0} -Factor	[mm/kN]	0,18	0,15	0,12	0,10	0,09	0,08	0,07	0,07	0,06	0,06	0,06	0,05	0,05	0,05	0,04	0,04	0,04
$\delta_{V\infty}$ -Factor		0,27	0,22	0,18	0,16	0,14	0,12	0,11	0,10	0,09	0,09	0,08	0,08	0,07	0,07	0,06	0,06	0,05
1) Calculation of effective displacement: $\delta_{N0} = \delta_{N0\text{-Factor}} \cdot \tau$ $\delta_{N\infty} = \delta_{N\infty\text{-Factor}} \cdot \tau$ $\tau =$ acting bond strength under tension loading									2) Calculation of effective displacement: $\delta_{V0} = \delta_{V0\text{-Factor}} \cdot V$ $\delta_{V\infty} = \delta_{V\infty\text{-Factor}} \cdot V$ $V =$ acting shear loading									

Table C21.2: Displacements for metric fischer FRA

fischer FRA	M12	M16	M20	M24	
Displacement-Factors for tension loading ¹⁾					
Uncracked or cracked concrete; Temperature range I, II, III					
δ_{N0} -Factor	0,09		0,10	0,11	0,12
$\delta_{N\infty}$ -Factor	0,13		0,15	0,16	0,18
Displacement-Factors for shear loading ²⁾					
Uncracked or cracked concrete; Temperature range I, II, III					
δ_{V0} -Factor	0,12		0,09	0,07	0,06
$\delta_{V\infty}$ -Factor	0,18		0,14	0,11	0,09
1) Calculation of effective displacement: $\delta_{N0} = \delta_{N0\text{-Factor}} \cdot \tau$ $\delta_{N\infty} = \delta_{N\infty\text{-Factor}} \cdot \tau$ $\tau =$ acting bond strength under tension loading		2) Calculation of effective displacement: $\delta_{V0} = \delta_{V0\text{-Factor}} \cdot V$ $\delta_{V\infty} = \delta_{V\infty\text{-Factor}} \cdot V$ $V =$ acting shear loading			

fischer Injection System FIS EM PLUS
Performance
 Displacements for reinforcing bars and fischer FRA

Annex C21
 Appendix 49 / 28

Table C22.1: Characteristic resistance to steel failure under tension loading for fractional Threaded rods part 1

Threaded rod		3/8"	1/2"	5/8"	3/4"	7/8"	1"	1 1/8"		
Characteristic resistance to steel failure under tension loading										
Characteristic resistance $N_{Rk,s}$	Steel zinc plated	F568M, Class 5.8	[kN]	25,0	45,7	72,9	107,9	148,9	195,4	246,0
		F1554, Grade 36		19,9	36,5	58,3	86,2	119,1	156,2	196,7
		F1554, Grade 55		25,8	47,3	75,3	111,5	154,0	202,0	254,4
		F1554, Grade 105		43,0	78,8	125,6	185,9	256,7	336,8	424,0
		A193, B7		43,0	78,8	125,6	185,9	256,7	336,8	424,0
	Stainless steel R	F593, Alloy Group 2		34,4	63,0	100,5	126,4	174,5	229,0	288,3
		A193, Grade B8M, Class 1		25,8	47,3	75,3	111,5	154,0	202,0	254,4
		A193, Grade B8M, Class 2B		32,7	59,9	95,4	141,3	195,1	255,9	322,2

Partial factors ¹⁾

Partial factor $\gamma_{Ms,N}$	Steel zinc plated	F568M, Class 5.8	[-]	1,50		
		F1554, Grade 36		1,94		
		F1554, Grade 55		1,64		
		F1554, Grade 105		1,43		
		A193, B7		1,43		
	Stainless steel R	F593, Alloy Group 2		1,85	2,27	
		A193, Grade B8M, Class 1		3,00		
		A193, Grade B8M, Class 2B		1,52		

¹⁾ In absence of other national regulations.

Table C23.1: Characteristic resistance to steel failure under shear loading for fractional Threaded rods part 2

Threaded rod		3/8	1/2"	5/8"	3/4"	7/8"	1"	1 1/8"		
Characteristic resistance to steel failure under shear loading										
Without lever arm										
Characteristic resistance $V_{Rk,s}^0$	Steel zinc plated	F568M, Class 5.8	[kN]	15,0	27,4	43,7	64,7	89,3	117,2	147,6
		F1554, Grade 36		11,9	21,9	34,9	51,7	71,4	93,7	118,0
		F1554, Grade 55		12,9	23,6	37,6	55,7	77,0	101,0	127,2
		F1554, Grade 105		21,5	39,4	62,8	92,9	128,3	168,4	212,0
	Stainless steel R	A193, B7		21,5	39,4	62,8	92,9	128,3	168,4	212,0
		F593, Alloy Group 2		17,2	31,5	50,2	63,2	87,2	114,5	144,1
		A193, Grade B8M, Class 1		12,9	23,6	37,6	55,7	77,0	101,0	127,2
		A193, Grade B8M, Class 2B		16,3	29,9	47,7	70,6	97,5	127,9	161,1
Ductility factor		k_7	[-]	1,0						
With lever arm										
Charact. resistance $M_{Rk,s}^0$	Steel zinc plated	F568M, Class 5.8	[Nm]	29,9	74,0	148,9	268,2	435,1	653,8	923,5
		F1554, Grade 36		23,9	59,2	119,1	214,5	348,0	522,9	738,6
		F1554, Grade 55		30,9	76,6	154,0	277,4	450,0	676,1	955,1
		F1554, Grade 105		51,5	127,6	256,8	462,4	750,0	1126,9	1591,9
	Stainless steel R	A193, B7		51,5	127,6	256,8	462,4	750,0	1126,9	1591,9
		F593, Alloy Group 2		41,2	102,1	205,4	314,4	510,0	766,3	1082,5
		A193, Grade B8M, Class 1		30,9	76,6	154,0	277,4	450,0	676,1	955,1
		A193, Grade B8M, Class 2B		39,1	97,0	195,1	351,4	570,0	856,4	1209,8
Partial factors ¹⁾										
Partial factor $\gamma_{Ms,V}$	Steel zinc plated	F568M, Class 5.8	[-]	1,25						
		F1554, Grade 36		1,61						
		F1554, Grade 55		1,36						
		F1554, Grade 105		1,50						
	Stainless steel R	A193, B7		1,50						
		F593, Alloy Group 2		1,54				1,89		
		A193, Grade B8M, Class 1		2,50						
		A193, Grade B8M, Class 2B		1,27						

¹⁾ In absence of other national regulations.

fischer Injection System FIS EM PLUS

Performance

Characteristic resistance to steel failure under tension / shear loading for fractional Anchor rods / Threaded rods part 2

Annex C23

Appendix 51 / 28

Table C24.1: Characteristic resistance to steel failure under tension loading for fractional fischer RG M I part 1

fischer RG M I		3/8"	1/2"	5/8"	3/4"		
Characteristic resistance to steel failure under tension loading							
Characteristic resistance with Screw or Threaded rod $N_{Rk,s}$	Steel zinc plated	F568M, Class 5.8	[kN]	25,0	45,7	72,9	107,9
		F1554, Grade 36		20,0	36,6	58,3	86,3
		F1554, Grade 55		25,8	47,3	75,3	111,5
		F1554, Grade 105		43,1	76,4	110,8	186,0
	Stainless steel R	A193, B7		43,1	76,4	110,8	186,0
		F593, Alloy Group 2		34,4	63,0	100,4	126,4
		A193, Grade B8M, Class 1		25,8	47,3	75,3	111,5
		A193, Grade B8M, Class 2B		32,7	59,9	95,4	141,3

Partial factors ¹⁾						
Partial factor $\gamma_{Ms,N}$	Steel zinc plated	F568M, Class 5.8	[-]	1,50		
		F1554, Grade 36		1,94		
		F1554, Grade 55		1,64		
		F1554, Grade 105		1,43	1,50	
	Stainless steel R	A193, B7		1,43	1,50	
		F593, Alloy Group 2		1,85		2,27
		A193, Grade B8M, Class 1		3,00		
		A193, Grade B8M, Class 2B		1,52		

¹⁾ In absence of other national regulations.

Table C25.1: Characteristic resistance to steel failure under shear loading for fractional fischer RG M I part 2

fischer RG M I		3/8"	1/2"	5/8"	3/4"			
Characteristic resistance to steel failure under shear loading								
Without lever arm								
Characteristic resistance with Screw or Threaded rod $V_{Rk,s}^0$	Steel zinc plated	Property class of Screw or Threaded rod	F568M, Class 5.8	[kN]	15,0	27,4	43,7	64,7
			F1554, Grade 36		11,9	21,9	34,9	51,7
			F1554, Grade 55		12,9	23,6	37,6	55,7
			F1554, Grade 105		21,5	39,4	62,8	92,9
	Stainless steel R		A193, B7		21,5	39,4	62,8	92,9
			F593, Alloy Group 2		17,2	31,5	50,2	63,2
			A193, Grade B8M, Class 1		12,9	23,6	37,6	55,7
			A193, Grade B8M, Class 2B		16,3	29,9	47,7	70,6
Ductility factor	k_7	[-]	1,0					
With lever arm								
Characteristic resistance with Screw or Threaded rod $M_{Rk,s}^0$	Steel zinc plated	Property class of Screw or Threaded rod	F568M, Class 5.8	[Nm]	29,9	74,0	148,9	268,2
			F1554, Grade 36		23,9	59,2	119,1	214,5
			F1554, Grade 55		30,9	76,6	154,0	277,4
			F1554, Grade 105		51,5	127,6	256,8	462,4
	Stainless steel R		A193, B7		51,5	127,6	256,8	462,4
			F593, Alloy Group 2		41,2	102,1	205,4	314,4
			A193, Grade B8M, Class 1		30,9	76,6	154,0	277,4
			A193, Grade B8M, Class 2B		39,1	97,0	195,1	351,4
Partial factors ¹⁾								
Partial factort $\gamma_{Ms,V}$	Steel zinc plated	Property class of Screw or Threaded rod	F568M, Class 5.8	[-]	1,25			
			F1554, Grade 36		1,61			
			F1554, Grade 55		1,36			
			F1554, Grade 105		1,50			
	Stainless steel R		A193, B7		1,50			
			F593, Alloy Group 2		1,54	1,89		
			A193, Grade B8M, Class 1		2,50			
			A193, Grade B8M, Class 2B		1,27			

¹⁾ In absence of other national regulations.

fischer Injection System FIS EM PLUS

Performance

Characteristic resistance to steel failure under shear loading for fractional fischer RG M I part 2

Annex C25

Appendix 53 / 28

Table C26.1: Characteristic resistance to steel failure under tension / shear loading for fractional reinforcing bars

Rebar size	#3	#4	#5	#6	#7	#8	#9	#10 ¹⁾
Characteristic resistance to steel failure under tension loading								
Characteristic resistance	$N_{Rk,s}$	[kN]	$A_s \cdot f_{uk}^{2)}$					
Characteristic resistance to steel failure under shear loading								
Without lever arm								
Characteristic resistance	$V_{Rk,s}^0$	[kN]	$k_6^{3)} \cdot A_s \cdot f_{uk}^{2)}$					
Ductility factor	k_7	[-]	1,0					
With lever arm								
Characteristic resistance	$M_{Rk,s}^0$	[Nm]	$1,2 \cdot W_{el} \cdot f_{uk}^{2)}$					

1) Not allowed for hollow drill bit.

2) f_{uk} respectively shall be taken from the specifications of the reinforcing bar.

3) In accordance with EN 1992-4:2018 section 7.2.2.3.1:

- $k_6 = 0,6$ for fasteners made of carbon steel with $f_{uk} \leq 500 \text{ N/mm}^2$,
- $= 0,5$ for fasteners made of carbon steel with $500 \text{ N/mm}^2 < f_{uk} \leq 1000 \text{ N/mm}^2$,
- $= 0,5$ for fasteners made of stainless steel.

fischer Injection System FIS EM PLUS

Performance

Characteristic resistance to steel failure under tension / shear loading for reinforcing bars

Annex C26

Appendix 54 / 28

Table C27.1: Characteristic resistance for concrete failure under tension / shear loading for fractional sizes

Size		All sizes								
Characteristic resistance to concrete failure under tension loading										
Installation factor	γ_{inst}	[-]	See Annex C28 to C37, C49 and C50							
Factors for the compressive strength of concrete > C20/25										
Increasing factor ψ_c for cracked or uncracked concrete $\tau_{Rk(X,Y)} = \psi_c \cdot \tau_{Rk(C20/25)}$	C25/30	ψ_c	[-]	1,02						
	C30/37			1,04						
	C35/45			1,06						
	C40/50			1,07						
	C45/55			1,08						
	C50/60			1,09						
Splitting failure										
Edge distance	$h / h_{ef} \geq 2,0$	$C_{cr,sp}$	[mm]	1,0 h_{ef}						
	$2,0 > h / h_{ef} > 1,3$			4,6 h_{ef} - 1,8 h						
	$h / h_{ef} \leq 1,3$			2,26 h_{ef}						
Spacing	$S_{cr,sp}$			2 $c_{cr,sp}$						
Concrete cone failure										
Uncracked concrete	$k_{Ucr,N}$	[-]	11,0 ¹⁾							
Cracked concrete	$k_{cr,N}$		7,7 ¹⁾							
Edge distance	$C_{cr,N}$	[mm]	1,5 h_{ef}							
Spacing	$S_{cr,N}$		2 $c_{cr,N}$							
Factors for sustained tension loading										
Temperature range			24 °C / 40 °C	35 °C / 60 °C	50 °C / 72 °C					
Factor	ψ_{sus}^0	[-]	1,0	1,0	0,7					
Factor	$\psi_{sus,100}^0$	[-]	1,0	1,0	1,0					
Characteristic resistance to concrete failure under shear loading										
Installation factor	γ_{inst}	[-]	1,0							
Concrete pry-out failure										
Factor for pry-out failure	k_8	[-]	2,0							
Concrete edge failure										
Effective length of fastener in shear loading	l_f	[mm]	for $d_{nom} \leq 24$ mm: min (h_{ef} ; 12 d_{nom}) for $d_{nom} > 24$ mm: min (h_{ef} ; max (8 d_{nom} ; 300 mm))							
Calculation diameters										
Size			3/8"	1/2"	5/8"	3/4"	7/8"	1"	1 1/8"	
Anchor rods and Threaded rods	d_{nom}	[mm]	9,5	12,7	15,9	19,1	22,2	25,4	28,6	
fischer RG M I	d_{nom}		15,7	18,0	22,0	28,0	-2)	-2)	-2)	
Rebar size			#3	#4	#5	#6	#7	#8	#9	#10
Reinforcing bar	d_{nom}	[mm]	9,5	12,7	15,9	19,1	22,2	25,4	28,7	32,3

1) Values only valid when using SI units.

2) Anchor type not part of the assessment.

fischer Injection System FIS EM PLUS

Performance

Characteristic resistance for concrete failure under tension / shear loading for fractional sizes

Annex C27

Appendix 55 / 28

Table C28.1: Characteristic resistance to combined pull-out and concrete failure for fractional Threaded rods in hammer or diamond drilled holes; uncracked concrete; working life 50 years

Threaded rod			3/8"	1/2"	5/8"	3/4"	7/8"	1"	1 1/8"		
Combined pull-out and concrete cone failure											
Calculation diameter	d	[mm]	9,5	12,7	15,9	19,1	22,2	25,4	28,6		
Uncracked concrete											
Characteristic bond resistance in uncracked concrete C20/25											
Hammer-drilling with standard drill bit or hollow drill bit (dry or wet concrete)											
Tem- perature range	I: 24 °C / 40 °C		$\tau_{Rk,ucr}$	[N/mm ²]	20,0	18,6	17,7	16,8	16,2	15,8	15,3
	II: 35 °C / 60 °C				18,0	18,0	17,0	16,0	15,0	15,0	14,0
	III: 50 °C / 72 °C				17,0	17,0	16,0	15,0	14,0	14,0	13,0
Hammer-drilling with standard drill bit or hollow drill bit (water filled hole)											
Tem- perature range	I: 24 °C / 40 °C		$\tau_{Rk,ucr}$	[N/mm ²]	20,0	18,6	17,0	15,4	14,3	13,7	12,8
	II: 35 °C / 60 °C				16,0	15,0	13,0	11,0	11,0	10,0	9,0
	III: 50 °C / 72 °C				14,0	14,0	12,0	11,0	10,0	9,0	9,0
Installation factors; Hammer-drilling with standard drill bit or hollow drill bit											
Dry or wet concrete		γ_{inst}	[-]	1,0							
Water filled hole				1,4							
Diamond-drilling (dry or wet concrete)											
Tem- perature range	I: 24 °C / 40 °C		$\tau_{Rk,ucr}$	[N/mm ²]	14,4	13,3	12,3	11,8	11,3	10,8	10,3
	II: 35 °C / 60 °C				15,0	13,0	12,0	10,0	10,0	9,0	9,0
	III: 50 °C / 72 °C				14,0	12,0	11,0	10,0	9,0	8,0	8,0
Diamond-drilling (water filled hole)											
Tem- perature range	I: 24 °C / 40 °C		$\tau_{Rk,ucr}$	[N/mm ²]	17,3	15,0	13,6	12,4	11,5	10,8	10,1
	II: 35 °C / 60 °C				15,0	13,0	12,0	10,0	10,0	9,0	9,0
	III: 50 °C / 72 °C				14,0	12,0	11,0	10,0	9,0	8,0	8,0
Installation factors; Diamond-drilling											
Dry or wet concrete		γ_{inst}	[-]	1,0							
Water filled hole				1,4							

fischer Injection System FIS EM PLUS

Performance

Characteristic resistance to combined pull-out and concrete failure for fractional Threaded rods; working life 50 years

Annex C28

Appendix 56 / 28

Table C29.1: Characteristic resistance to combined pull-out and concrete failure for fractional Threaded rods in hammer or diamond drilled holes; cracked concrete; working life 50 years

Threaded rod			3/8"	1/2"	5/8"	3/4"	7/8"	1"	1 1/8"		
Combined pull-out and concrete cone failure											
Calculation diameter	d	[mm]	9,5	12,7	15,9	19,1	22,2	25,4	28,6		
Cracked concrete											
Characteristic bond resistance in cracked concrete C20/25											
Hammer-drilling with standard drill bit or hollow drill bit (dry or wet concrete)											
Tem- perature range	I: 24 °C / 40 °C		$\tau_{Rk,cr}$	[N/mm ²]	8,7	9,9	9,5	8,5	8,5	8,5	
	II: 35 °C / 60 °C				8,7	9,9	9,5	8,5	8,5	8,5	8,5
	III: 50 °C / 72 °C				8,2	9,3	8,9	8,5	8,5	8,5	8,5
Hammer-drilling with standard drill bit or hollow drill bit (water filled hole)											
Tem- perature range	I: 24 °C / 40 °C		$\tau_{Rk,cr}$	[N/mm ²]	7,5	8,5	7,8	6,0	6,0	6,0	
	II: 35 °C / 60 °C				7,5	8,5	7,8	6,0	6,0	6,0	6,0
	III: 50 °C / 72 °C				7,0	8,0	7,3	6,0	6,0	6,0	6,0
Installation factors; Hammer-drilling with standard drill bit or hollow drill bit											
Dry or wet concrete		γ_{inst}	[-]	1,0							
Water filled hole				1,2			1,4				
Diamond-drilling (dry or wet concrete)											
Tem- perature range	I: 24 °C / 40 °C		$\tau_{Rk,cr}$	[N/mm ²]	7,0	7,0	6,0	6,0	7,0	7,0	
	II: 35 °C / 60 °C				7,0	7,0	6,0	6,0	7,0	7,0	7,0
	III: 50 °C / 72 °C				7,0	7,0	6,0	6,0	7,0	7,0	7,0
Diamond-drilling (water filled hole)											
Tem- perature range	I: 24 °C / 40 °C		$\tau_{Rk,cr}$	[N/mm ²]	7,5	7,5	6,0	6,0	6,0	6,0	
	II: 35 °C / 60 °C				7,5	7,5	6,0	6,0	6,0	6,0	6,0
	III: 50 °C / 72 °C				7,0	7,0	6,0	6,0	6,0	6,0	6,0
Installation factors; Diamond-drilling											
Dry or wet concrete		γ_{inst}	[-]	1,0							
Water filled hole				1,2			1,4				

fischer Injection System FIS EM PLUS

Performance

Characteristic resistance to combined pull-out and concrete failure for fractional Threaded rods; working life 50 years

Annex C29

Appendix 57 / 28

Table C30.1: Characteristic resistance to combined pull-out and concrete failure for fractional Threaded rods in hammer or diamond drilled holes; uncracked concrete; working life 100 years

Threaded rod			3/8"	1/2"	5/8"	3/4"	7/8"	1"	1 1/8"		
Combined pull-out and concrete cone failure											
Calculation diameter	d	[mm]	9,5	12,7	15,9	19,1	22,2	25,4	28,6		
Uncracked concrete											
Characteristic bond resistance in uncracked concrete C20/25											
Hammer-drilling with standard drill bit or hollow drill bit (dry or wet concrete)											
Tem- perature range	I: 24 °C / 40 °C		$\tau_{Rk,100,ucr}$	[N/mm ²]	16,4	15,3	14,5	13,8	13,3	12,9	12,6
	II: 35 °C / 60 °C				13,5	13,5	12,8	12,0	11,3	11,3	10,5
	III: 50 °C / 72 °C				10,2	10,2	10,4	9,8	9,1	9,1	8,5
Hammer-drilling with standard drill bit or hollow drill bit (water filled hole)											
Tem- perature range	I: 24 °C / 40 °C		$\tau_{Rk,100,ucr}$	[N/mm ²]	16,4	15,3	13,9	12,6	11,7	11,2	10,5
	II: 35 °C / 60 °C				12,0	11,3	9,8	8,3	8,3	7,5	6,8
	III: 50 °C / 72 °C				8,4	8,4	7,8	7,2	6,5	5,9	5,9
Installation factors; Hammer-drilling with standard drill bit or hollow drill bit											
Dry or wet concrete			γ_{inst}	[-]	1,0						
Water filled hole					1,4						
Diamond-drilling (dry or wet concrete)											
Tem- perature range	I: 24 °C / 40 °C		$\tau_{Rk,100,ucr}$	[N/mm ²]	11,8	10,8	10,1	9,7	9,3	8,8	8,5
	II: 35 °C / 60 °C				11,3	9,8	9,0	7,5	7,5	6,8	6,8
	III: 50 °C / 72 °C				8,4	7,2	7,2	6,5	5,9	5,2	5,2
Diamond-drilling (water filled hole)											
Tem- perature range	I: 24 °C / 40 °C		$\tau_{Rk,100,ucr}$	[N/mm ²]	14,2	12,3	11,2	10,2	9,4	8,9	8,3
	II: 35 °C / 60 °C				11,3	9,8	9,0	7,5	7,5	6,8	6,8
	III: 50 °C / 72 °C				8,4	7,2	7,2	6,5	5,9	5,2	5,2
Installation factors; Diamond-drilling											
Dry or wet concrete			γ_{inst}	[-]	1,0						
Water filled hole					1,4						

fischer Injection System FIS EM PLUS

Performance

Characteristic resistance to combined pull-out and concrete failure for fractional Threaded rods in hammer or diamond drilled holes; working life 100 years

Annex C30

Appendix 58 / 28

Table C31.1: Characteristic resistance to combined pull-out and concrete failure for fractional Threaded rods in hammer or diamond drilled holes; cracked concrete; working life 100 years

Threaded rod			3/8"	1/2"	5/8"	3/4"	7/8"	1"	1 1/8"	
Combined pull-out and concrete cone failure										
Calculation diameter	d	[mm]	9,5	12,7	15,9	19,1	22,2	25,4	28,6	
Cracked concrete										
Characteristic bond resistance in cracked concrete C20/25										
Hammer-drilling with standard drill bit or hollow drill bit (dry or wet concrete)										
Tem- perature range	I: 24 °C / 40 °C	$\tau_{Rk,100,cr}$	[N/mm ²]	7,0	7,5	7,2	6,9	6,8	6,5	6,3
	II: 35 °C / 60 °C			7,0	7,5	7,2	6,9	6,8	6,5	6,3
	III: 50 °C / 72 °C			6,6	7,1	6,8	6,4	6,4	6,1	6,0
Hammer-drilling with standard drill bit or hollow drill bit (water filled hole)										
Tem- perature range	I: 24 °C / 40 °C	$\tau_{Rk,100,cr}$	[N/mm ²]	6,0	6,5	5,9	4,9	4,8	4,6	4,4
	II: 35 °C / 60 °C			6,0	6,5	5,9	4,9	4,8	4,6	4,4
	III: 50 °C / 72 °C			5,6	6,1	5,5	4,5	4,5	4,3	4,3
Installation factors; Hammer-drilling with standard drill bit or hollow drill bit										
Dry or wet concrete	γ_{inst}	[-]	1,0							
Water filled hole			1,2	1,4						
Diamond-drilling (dry or wet concrete)										
Tem- perature range	I: 24 °C / 40 °C	$\tau_{Rk,100,cr}$	[N/mm ²]	6,0	5,6	3,9	3,9	4,6	4,6	4,6
	II: 35 °C / 60 °C			6,0	5,6	3,9	3,9	4,6	4,6	4,6
	III: 50 °C / 72 °C			6,0	5,6	3,9	3,9	4,6	4,6	4,6
Installation factors; Diamond-drilling										
Dry or wet concrete	γ_{inst}	[-]	1,0							
fischer Injection System FIS EM PLUS										
Performance Characteristic resistance to combined pull-out and concrete failure for fractional Threaded rods in hammer or diamond drilled holes; working life 100 years								Annex C31 Appendix 59 / 28		

Table C32.1: Characteristic resistance to combined pull-out and concrete failure for fractional fischer RG M I in hammer or diamond drilled holes; uncracked concrete; working life 50 years

fischer RG M I		3/8"	1/2"	5/8"	3/4"	
Combined pull-out and concrete cone failure						
Calculation diameter	d [mm]	15,7	18,0	22,0	28,0	
Uncracked concrete						
Characteristic bond resistance in uncracked concrete C20/25						
Hammer-drilling with standard drill bit or hollow drill bit (dry or wet concrete)						
Tem- perature range	I: 24 °C / 40 °C	$\tau_{Rk,ucr}$ [N/mm ²]	17,6	17,0	16,2	15,3
	II: 35 °C / 60 °C		14,0	14,0	13,0	12,0
	III: 50 °C / 72 °C		13,0	13,0	12,0	11,0
Hammer-drilling with standard drill bit or hollow drill bit (water filled hole)						
Tem- perature range	I: 24 °C / 40 °C	$\tau_{Rk,ucr}$ [N/mm ²]	16,9	15,8	14,3	12,8
	II: 35 °C / 60 °C		12,0	12,0	11,0	10,0
	III: 50 °C / 72 °C		12,0	11,0	10,0	9,0
Installation factors; Hammer-drilling with standard drill bit or hollow drill bit						
Dry or wet concrete	γ_{inst}	[-]	1,0			
Water filled hole			1,4			
Diamond-drilling (dry or wet concrete)						
Tem- perature range	I: 24 °C / 40 °C	$\tau_{Rk,ucr}$ [N/mm ²]	12,3	11,9	11,2	10,4
	II: 35 °C / 60 °C		12,0	11,0	10,0	9,0
	III: 50 °C / 72 °C		11,0	10,0	9,0	8,0
Diamond-drilling (water filled hole)						
Tem- perature range	I: 24 °C / 40 °C	$\tau_{Rk,ucr}$ [N/mm ²]	13,6	12,6	11,4	10,2
	II: 35 °C / 60 °C		12,0	11,0	10,0	9,0
	III: 50 °C / 72 °C		11,0	10,0	9,0	8,0
Installation factors; Diamond-drilling						
Dry or wet concrete	γ_{inst}	[-]	1,0			
Water filled hole			1,4			

fischer Injection System FIS EM PLUS

Performance

Characteristic resistance to combined pull-out and concrete failure for fractional fischer RG M I; working life 50 years

Annex C32

Appendix 60 / 28

Table C33.1: Characteristic resistance to combined pull-out and concrete failure for fractional fischer RG M I in hammer or diamond drilled holes; cracked concrete; working life 50 years

fischer RG M I		3/8"	1/2"	5/8"	3/4"	
Combined pull-out and concrete cone failure						
Calculation diameter	d	[mm]	15,7	18,0	22,0	28,0
Cracked concrete						
Characteristic bond resistance in cracked concrete C20/25						
Hammer-drilling with standard drill bit or hollow drill bit (dry or wet concrete)						
Temperature range	I: 24 °C / 40 °C	$\tau_{Rk,cr}$ [N/mm ²]	6,0	6,0	7,0	7,0
	II: 35 °C / 60 °C		6,0	6,0	7,0	7,0
	III: 50 °C / 72 °C		6,0	6,0	7,0	7,0
Hammer-drilling with standard drill bit or hollow drill bit (water filled hole)						
Temperature range	I: 24 °C / 40 °C	$\tau_{Rk,cr}$ [N/mm ²]	6,5	6,0	6,0	6,0
	II: 35 °C / 60 °C		6,5	6,0	6,0	6,0
	III: 50 °C / 72 °C		6,0	6,0	6,0	6,0
Installation factors; Hammer-drilling with standard drill bit or hollow drill bit						
Dry or wet concrete	γ_{inst}	[-]	1,0			
Water filled hole			1,2	1,4		
Diamond-drilling (dry or wet concrete)						
Temperature range	I: 24 °C / 40 °C	$\tau_{Rk,cr}$ [N/mm ²]	6,0	6,0	7,0	7,0
	II: 35 °C / 60 °C		6,0	6,0	7,0	7,0
	III: 50 °C / 72 °C		6,0	6,0	7,0	7,0
Diamond-drilling (water filled hole)						
Temperature range	I: 24 °C / 40 °C	$\tau_{Rk,cr}$ [N/mm ²]	6,5	6,0	6,0	6,0
	II: 35 °C / 60 °C		6,5	6,0	6,0	6,0
	III: 50 °C / 72 °C		6,0	6,0	6,0	6,0
Installation factors; Diamond-drilling						
Dry or wet concrete	γ_{inst}	[-]	1,0			
Water filled hole			1,2	1,4		
fischer Injection System FIS EM PLUS						
Performance Characteristic resistance to combined pull-out and concrete failure for fractional fischer RG M I; working life 50 years					Annex C33 Appendix 61 / 28	

Table C34.1: Characteristic resistance to combined pull-out and concrete failure for fractional fischer RG M I in hammer or diamond drilled holes; uncracked or cracked concrete; working life 100 years

fischer RG M I		3/8"	1/2"	5/8"	3/4"	
Combined pull-out and concrete cone failure						
Calculation diameter	d	[mm]	15,7	18,0	22,0	28,0
Uncracked concrete						
Characteristic bond resistance in uncracked concrete C20/25						
Hammer-drilling with standard drill bit or hollow drill bit (dry or wet concrete)						
Temperature range	I: 24 °C / 40 °C	$\tau_{Rk,100,ucr}$ [N/mm ²]	14,4	14,0	13,3	12,6
	II: 35 °C / 60 °C		10,5	10,5	9,8	9,0
	III: 50 °C / 72 °C		7,8	7,8	7,8	7,2
Hammer-drilling with standard drill bit or hollow drill bit (water filled hole)						
Temperature range	I: 24 °C / 40 °C	$\tau_{Rk,100,ucr}$ [N/mm ²]	13,9	13,0	11,7	10,5
	II: 35 °C / 60 °C		9,0	9,0	8,3	7,5
	III: 50 °C / 72 °C		7,2	6,6	6,5	5,9
Installation factors; Hammer-drilling with standard drill bit or hollow drill bit						
Dry or wet concrete		[-]	1,0			
Water filled hole	γ_{inst}		1,4			
Diamond-drilling (dry or wet concrete)						
Temperature range	I: 24 °C / 40 °C	$\tau_{Rk,100,ucr}$ [N/mm ²]	10,1	9,8	9,2	8,6
	II: 35 °C / 60 °C		9,0	8,3	7,5	6,8
	III: 50 °C / 72 °C		6,6	6,0	5,9	5,2
Diamond-drilling (water filled hole)						
Temperature range	I: 24 °C / 40 °C	$\tau_{Rk,100,ucr}$ [N/mm ²]	11,2	10,3	9,3	8,4
	II: 35 °C / 60 °C		9,0	8,3	7,5	6,8
	III: 50 °C / 72 °C		6,6	6,0	5,9	5,2
Installation factors; Diamond-drilling						
Dry or wet concrete		[-]	1,0			
Water filled hole	γ_{inst}		1,4			
Cracked concrete						
Characteristic bond resistance in cracked concrete C20/25						
Hammer-drilling with standard drill bit or hollow drill bit (dry or wet concrete)						
Temperature range	I: 24 °C / 40 °C	$\tau_{Rk,100,cr}$ [N/mm ²]	5,1	4,8	4,6	4,6
	II: 35 °C / 60 °C		5,1	4,8	4,6	4,6
	III: 50 °C / 72 °C		5,1	4,8	4,6	4,6
Hammer-drilling with standard drill bit or hollow drill bit (water filled hole)						
Temperature range	I: 24 °C / 40 °C	$\tau_{Rk,100,cr}$ [N/mm ²]	5,5	4,8	3,9	3,9
	II: 35 °C / 60 °C		5,5	4,8	3,9	3,9
	III: 50 °C / 72 °C		5,1	4,8	3,9	3,9
Installation factors; Hammer-drilling with standard drill bit or hollow drill bit						
Dry or wet concrete		[-]	1,0			
Water filled hole	γ_{inst}		1,2		1,4	
Diamond-drilling (dry or wet concrete)						
Temperature range	I: 24 °C / 40 °C	$\tau_{Rk,100,cr}$ [N/mm ²]	5,1	4,8	4,6	4,6
	II: 35 °C / 60 °C		5,1	4,8	4,6	4,6
	III: 50 °C / 72 °C		5,1	4,8	4,6	4,6
Installation factors; Diamond-drilling						
Dry or wet concrete		[-]	1,0			

fischer Injection System FIS EM PLUS

Performance

Characteristic resistance to combined pull-out and concrete failure for fractional fischer RG M I; working life 100 years

Annex C34

Appendix 62 / 28

Table C35.1: Characteristic resistance to combined pull-out and concrete failure for fractional reinforcing bars in hammer or diamond drilled holes; uncracked concrete; working life 50 years

Rebar size		#3	#4	#5	#6	#7	#8	#9	#10 ¹⁾		
Combined pull-out and concrete cone failure											
Calculation diameter	d	[mm]	9,5	12,7	15,9	19,1	22,2	25,4	28,7	32,3	
Uncracked concrete											
Characteristic bond resistance in uncracked concrete C20/25											
Hammer-drilling with standard drill bit or hollow drill bit (dry or wet concrete)											
Tem- perature range	I: 24 °C / 40 °C	$\tau_{Rk,ucr}$	[N/mm ²]	17,0	15,9	15,1	14,4	13,9	13,4	13,1	12,7
	II: 35 °C / 60 °C			15,0	15,0	14,0	13,0	13,0	12,0	12,0	12,0
	III 50 °C / 72 °C			14,0	14,0	13,0	12,0	12,0	11,0	11,0	11,0
Hammer-drilling with standard drill bit or hollow drill bit (water filled hole)											
Tem- perature range	I: 24 °C / 40 °C	$\tau_{Rk,ucr}$	[N/mm ²]	17,0	15,9	14,5	13,2	12,3	11,6	10,5	10,2
	II: 35 °C / 60 °C			16,0	14,0	12,0	11,0	11,0	10,0	10,0	9,0
	III 50 °C / 72 °C			14,0	13,0	12,0	11,0	10,0	9,0	9,0	8,0
Installation factors; Hammer-drilling with standard drill bit or hollow drill bit											
Dry or wet concrete	γ_{inst}	[-]	1,0								
Water filled hole			1,4								
Diamond-drilling (dry or wet concrete as well as water filled hole)											
Tem- perature range	I: 24 °C / 40 °C	$\tau_{Rk,ucr}$	[N/mm ²]	15,0	13,0	12,0	10,0	10,0	9,0	9,0	8,0
	II: 35 °C / 60 °C			15,0	13,0	12,0	10,0	10,0	9,0	9,0	8,0
	III 50 °C / 72 °C			14,0	12,0	11,0	10,0	9,0	9,0	8,0	8,0
Installation factors; Diamond-drilling											
Dry or wet concrete	γ_{inst}	[-]	1,0								
Water filled hole			1,4								

¹⁾ Not allowed for drilling with hollow drill bit.

fischer Injection System FIS EM PLUS

Performance

Characteristic resistance to combined pull-out and concrete failure for fractional reinforcing bars; working life 50 years

Annex C35

Appendix 63 / 28

Table C36.1: Characteristic resistance to combined pull-out and concrete failure for fractional reinforcing bars in hammer or diamond drilled holes; cracked concrete; working life 50 years

Rebar size		#3	#4	#5	#6	#7	#8	#9	#10 ¹⁾		
Combined pull-out and concrete cone failure											
Calculation diameter	d	[mm]	9,5	12,7	15,9	19,1	22,2	25,4	28,7	32,3	
Cracked concrete											
Characteristic bond resistance in cracked concrete C20/25											
Hammer-drilling with standard drill bit or hollow drill bit (dry or wet concrete)											
Tem- perature range	I: 24 °C / 40 °C	$\tau_{Rk,cr}$	[N/mm ²]	7,0	8,0	8,0	8,0	8,0	8,0	8,0	
	II: 35 °C / 60 °C			7,0	8,0	8,0	8,0	8,0	8,0	8,0	8,0
	III: 50 °C / 72 °C			7,0	8,0	8,0	8,0	8,0	8,0	8,0	8,0
Hammer-drilling with standard drill bit or hollow drill bit (water filled hole)											
Tem- perature range	I: 24 °C / 40 °C	$\tau_{Rk,cr}$	[N/mm ²]	7,5	6,5	6,5	6,0	6,0	6,0	5,0	
	II: 35 °C / 60 °C			7,5	6,5	6,5	6,0	6,0	6,0	6,0	5,0
	III: 50 °C / 72 °C			6,5	6,5	6,0	6,0	6,0	6,0	6,0	5,0
Installation factors; Hammer-drilling with standard drill bit or hollow drill bit											
Dry or wet concrete	γ_{inst}	[-]	1,0								
Water filled hole			1,2			1,4					
Diamond-drilling (dry or wet concrete)											
Tem- perature range	I: 24 °C / 40 °C	$\tau_{Rk,cr}$	[N/mm ²]	7,0	7,0	6,0	6,0	7,0	7,0	5,0	
	II: 35 °C / 60 °C			7,0	7,0	6,0	6,0	7,0	7,0	7,0	5,0
	III: 50 °C / 72 °C			7,0	7,0	6,0	6,0	7,0	7,0	7,0	5,0
Diamond-drilling (water filled hole)											
Tem- perature range	I: 24 °C / 40 °C	$\tau_{Rk,cr}$	[N/mm ²]	7,5	6,5	6,5	6,0	6,0	6,0	5,0	
	II: 35 °C / 60 °C			7,5	6,5	6,5	6,0	6,0	6,0	6,0	5,0
	III: 50 °C / 72 °C			6,5	6,5	6,0	6,0	6,0	6,0	6,0	5,0
Installation factors; Diamond-drilling											
Dry or wet concrete	γ_{inst}	[-]	1,0								
Water filled hole			1,2			1,4					

1) Not allowed for drilling with hollow drill bit.

fischer Injection System FIS EM PLUS

Performance

Characteristic resistance to combined pull-out and concrete failure for fractional reinforcing bars; working life 50 years

Annex C36

Appendix 64 / 28

Table C37.1: Characteristic resistance to combined pull-out and concrete failure for fractional reinforcing bars in hammer or diamond drilled holes; uncracked and cracked concrete; working life 100 years

Rebar size		#3	#4	#5	#6	#7	#8	#9	#10 ¹⁾	
Combined pull-out and concrete cone failure										
Calculation diameter	d	[mm]	9,5	12,7	15,9	19,1	22,2	25,4	28,7	32,3
Uncracked concrete										
Characteristic bond resistance in uncracked concrete C20/25										
Hammer-drilling with standard drill bit or hollow drill bit (dry or wet concrete)										
Temperature range	I: 24 °C / 40 °C	$\tau_{Rk,100,ucr}$ [N/mm ²]	14,0	13,0	12,4	11,9	11,4	11,0	10,8	10,5
	II: 35 °C / 60 °C		11,3	11,3	10,5	9,8	9,8	9,0	9,0	9,0
	III 50 °C / 72 °C		8,4	8,4	8,5	7,8	7,8	7,2	7,2	7,2
Hammer-drilling with standard drill bit or hollow drill bit (water filled hole)										
Temperature range	I: 24 °C / 40 °C	$\tau_{Rk,100,ucr}$ [N/mm ²]	13,9	13,0	11,9	11,0	10,1	9,5	8,6	8,5
	II: 35 °C / 60 °C		12,0	10,5	9,0	8,3	8,3	7,5	7,5	6,8
	III 50 °C / 72 °C		8,4	7,8	7,8	7,2	6,5	5,9	5,9	5,2
Installation factors; Hammer-drilling with standard drill bit or hollow drill bit										
Dry or wet concrete	γ_{inst}	[-]	1,0							
Water filled hole			1,4							
Diamond-drilling (dry or wet concrete as well as water filled hole)										
Temperature range	I: 24 °C / 40 °C	$\tau_{Rk,100,ucr}$ [N/mm ²]	11,3	9,8	9,0	7,5	7,5	6,8	6,8	6,0
	II: 35 °C / 60 °C		11,3	9,8	9,0	7,5	7,5	6,8	6,8	6,0
	III 50 °C / 72 °C		8,4	7,2	7,2	6,5	5,9	5,9	5,2	5,2
Installation factors										
Dry or wet concrete	γ_{inst}	[-]	1,0							
Water filled hole			1,4							
Cracked concrete										
Characteristic bond resistance in cracked concrete C20/25										
Hammer-drilling with standard drill bit or hollow drill bit (dry or wet concrete)										
Temperature range	I: 24 °C / 40 °C	$\tau_{Rk,100,cr}$ [N/mm ²]	6,0	6,4	5,2	5,2	5,2	5,2	5,2	5,2
	II: 35 °C / 60 °C		6,0	6,4	5,2	5,2	5,2	5,2	5,2	5,2
	III 50 °C / 72 °C		6,0	6,4	5,2	5,2	5,2	5,2	5,2	5,2
Hammer-drilling with standard drill bit or hollow drill bit (water filled hole)										
Temperature range	I: 24 °C / 40 °C	$\tau_{Rk,100,cr}$ [N/mm ²]	6,4	5,2	4,2	3,9	3,9	3,9	3,9	3,3
	II: 35 °C / 60 °C		6,4	5,2	4,2	3,9	3,9	3,9	3,9	3,3
	III 50 °C / 72 °C		5,5	5,2	3,9	3,9	3,9	3,9	3,9	3,3
Installation factors; Hammer-drilling with standard drill bit or hollow drill bit										
Dry or wet concrete	γ_{inst}	[-]	1,0							
Water filled hole			1,2						1,4	
Diamond-drilling (dry or wet concrete)										
Temperature range	I: 24 °C / 40 °C	$\tau_{Rk,100,cr}$ [N/mm ²]	6,0	5,6	3,9	3,9	4,6	4,6	4,6	3,3
	II: 35 °C / 60 °C		6,0	5,6	3,9	3,9	4,6	4,6	4,6	3,3
	III 50 °C / 72 °C		6,0	5,6	3,9	3,9	4,6	4,6	4,6	3,3
Installation factors										
Dry or wet concrete	γ_{inst}	[-]	1,0							

¹⁾ Not allowed for drilling with hollow drill bit.

fischer Injection System FIS EM PLUS

Performance

Characteristic resistance to combined pull-out and concrete failure for fractional reinforcing bars; uncracked and cracked concrete; working life 100 years

Annex C37

Appendix 65 / 28

Table C38.1: Displacements for fraction Threaded rods

Threaded rod		3/8"	1/2"	5/8"	3/4"	7/8"	1"	1 1/8"
Displacement-Factors for tension loading ¹⁾								
Uncracked or cracked concrete; Temperature range I, II, III								
δ_{N0} -Factor	[mm/(N/mm ²)]	0,08	0,09	0,10	0,11	0,11	0,12	0,13
$\delta_{N\infty}$ -Factor		0,12	0,13	0,15	0,16	0,17	0,19	0,19
Displacement-Factors for shear loading ²⁾								
Uncracked or cracked concrete; Temperature range I, II, III								
δ_{V0} -Factor	[mm/kN]	0,15	0,12	0,09	0,07	0,07	0,05	0,05
$\delta_{V\infty}$ -Factor		0,22	0,18	0,14	0,11	0,10	0,08	0,07

1) Calculation of effective displacement:

$$\delta_{N0} = \delta_{N0\text{-Factor}} \cdot \tau$$

$$\delta_{N\infty} = \delta_{N\infty\text{-Factor}} \cdot \tau$$

 τ = acting bond strength under tension loading

2) Calculation of effective displacement:

$$\delta_{V0} = \delta_{V0\text{-Factor}} \cdot V$$

$$\delta_{V\infty} = \delta_{V\infty\text{-Factor}} \cdot V$$

 V = acting shear loading
Table C38.2: Displacements for fractional fischer RG M I

fischer RG M I		3/8"	1/2"	5/8"	3/4"
Displacement-Factors for tension loading ¹⁾					
Uncracked or cracked concrete; Temperature range I, II, III					
δ_{N0} -Factor	[mm/(N/mm ²)]	0,10	0,10	0,11	0,13
$\delta_{N\infty}$ -Factor		0,15	0,16	0,17	0,19
Displacement-Factors for shear loading ²⁾					
Uncracked or cracked concrete; Temperature range I, II, III					
δ_{V0} -Factor	[mm/kN]	0,09	0,08	0,07	0,05
$\delta_{V\infty}$ -Factor		0,14	0,12	0,10	0,08

1) Calculation of effective displacement:

$$\delta_{N0} = \delta_{N0\text{-Factor}} \cdot \tau$$

$$\delta_{N\infty} = \delta_{N\infty\text{-Factor}} \cdot \tau$$

 τ = acting bond strength under tension loading

2) Calculation of effective displacement:

$$\delta_{V0} = \delta_{V0\text{-Factor}} \cdot V$$

$$\delta_{V\infty} = \delta_{V\infty\text{-Factor}} \cdot V$$

 V = acting shear loading
fischer Injection System FIS EM PLUS**Performance**

Displacements for fractional Threaded rods and fractional fischer RG M I

Annex C38

Appendix 66 / 28

Table C39.1: Displacements for fractional reinforcing bars

Rebar size		#3	#4	#5	#6	#7	#8	#9	#10
Displacement-Factors for tension loading ¹⁾									
Uncracked or cracked concrete; Temperature range I, II, III									
δ_{N0} -Factor	[mm/(N/mm ²)]	0,08	0,09	0,10	0,11	0,11	0,12	0,13	0,13
$\delta_{N\infty}$ -Factor		0,12	0,13	0,15	0,16	0,17	0,18	0,19	0,20
Displacement-Factors for shear loading ²⁾									
Uncracked or cracked concrete; Temperature range I, II, III									
δ_{V0} -Factor	[mm/kN]	0,15	0,12	0,09	0,07	0,07	0,06	0,05	0,05
$\delta_{V\infty}$ -Factor		0,22	0,18	0,14	0,11	0,10	0,09	0,08	0,07

1) Calculation of effective displacement:

$$\delta_{N0} = \delta_{N0\text{-Factor}} \cdot \tau$$

$$\delta_{N\infty} = \delta_{N\infty\text{-Factor}} \cdot \tau$$

τ = acting bond strength under tension loading

2) Calculation of effective displacement:

$$\delta_{V0} = \delta_{V0\text{-Factor}} \cdot V$$

$$\delta_{V\infty} = \delta_{V\infty\text{-Factor}} \cdot V$$

V = acting shear loading

fischer Injection System FIS EM PLUS

Performance

Displacements for fractional reinforcing bars

Annex C39

Appendix 67 / 28

Table C40.1: Characteristic resistance to steel failure under tension / shear loading for metric Anchor rods and Threaded rods under seismic action performance category C1

Anchor rod / Threaded rod			M10	M12	M14	M16	M20	M22	M24	M27	M30	
Characteristic resistance to steel failure under tension loading ¹⁾												
Anchor rods and Threaded rods, performance category C1 ²⁾												
Characteristic resistance $N_{Rk,s,C1}$	Steel zinc plated	Property class 4.8	[kN]	23,2(21,4)	33,7	46,0	62,8	98,0	121,2	141,2	183,6	224,4
		5.8		29,0(26,8)	42,1	57,5	78,5	122,5	151,5	176,5	229,5	280,5
		8.8		46,4(42,8)	67,4	92,0	125,6	196,0	242,4	282,4	367,2	448,8
	Stainless steel R and high corrosion resistant steel HCR	50		29,0	42,1	57,5	78,5	122,5	151,5	176,5	229,5	280,5
		70		40,6	59,0	80,5	109,9	171,5	212,1	247,1	321,3	392,7
		80		46,4	67,4	92,0	125,6	196,0	242,4	282,4	367,2	448,8
Characteristic resistance to steel failure under shear loading without lever arm ¹⁾												
Anchor rods, performance category C1 ²⁾												
Characteristic resistance $V_{Rk,s,C1}$	Steel zinc plated	Property class 4.8	[kN]	13,9(12,8)	20,2	27,6	37,6	58,8	72,7	84,7	110,1	134,6
		5.8		17,4(16,0)	25,2	34,5	47,1	73,5	90,9	105,9	137,7	168,3
		8.8		23,2(21,4)	33,7	46,0	62,8	98,0	121,2	141,2	183,6	224,4
	Stainless steel R and high corrosion resistant steel HCR	50		14,5	21,0	28,7	39,2	61,2	75,7	88,2	114,7	140,2
		70		20,3	29,5	40,2	54,9	85,7	106,0	123,5	160,6	196,3
		80		23,2	33,7	46,0	62,8	98,0	121,2	141,2	183,6	224,4
Threaded rods, performance category C1 ²⁾												
Characteristic resistance $V_{Rk,s,C1}$	Steel zinc plated	Property class 4.8	[kN]	9,7(9,0)	14,1	19,3	26,3	41,1	50,9	59,3	77,1	97,2
		5.8		12,1(11,2)	17,7	24,1	32,9	51,4	63,6	74,1	96,3	117,8
		8.8		16,2(15,0)	23,6	32,2	43,9	68,6	84,8	98,8	128,5	157,0
	Stainless steel R and high corrosion resistant steel HCR	50		10,1	14,7	20,1	27,4	42,8	53,0	61,7	80,3	98,1
		70		14,2	20,6	28,1	38,4	60,0	74,2	86,4	112,4	137,4
		80		16,2	23,6	32,2	43,9	68,6	84,8	98,8	128,5	157,0

¹⁾ Values in brackets are valid for undersized Threaded rods with smaller stress area A_s for hot dip galvanised Threaded rods according to EN ISO 10684:2004+AC:2009.

²⁾ Partial factors for performance category C1 or C2 see table C42.1; for Anchor rods the factor for steel ductility is 1,0.

Table C41.1: Characteristic resistance to steel failure under tension / shear loading for metric Anchor rods and Threaded rods under seismic action performance category C2

Anchor rod / Threaded rod			M10	M12	M14	M16	M20	M22	M24	M27	M30		
Characteristic resistance to steel failure under tension loading													
Anchor rods and Threaded rods, performance category C2 ¹⁾													
Characteristic resistance $N_{Rk,s,C2}$	Steel zinc plated	Property class	4.8	[kN]	-2)	30,3	-2)	56,5	88,2	-2)	141,2	-2)	-2)
			5.8		-2)	37,9	-2)	70,6	110,2	-2)	176,5	-2)	-2)
			8.8		-2)	60,6	-2)	113,0	176,4	-2)	282,4	-2)	-2)
	Stainless steel R and high corrosion resistant steel HCR		50		-2)	37,9	-2)	70,6	110,2	-2)	176,5	-2)	-2)
			70		-2)	53,1	-2)	98,9	154,3	-2)	247,1	-2)	-2)
			80		-2)	60,6	-2)	113,0	176,4	-2)	282,4	-2)	-2)
Characteristic resistance to steel failure under shear loading without lever arm													
Anchor rods, performance category C2 ¹⁾													
Characteristic resistance $V_{Rk,s,C2}$	Steel zinc plated	Property class	4.8	[kN]	-2)	13,3	-2)	28,2	45,2	-2)	77,0	-2)	-2)
			5.8		-2)	16,6	-2)	35,3	56,5	-2)	96,3	-2)	-2)
			8.8		-2)	22,2	-2)	47,1	75,4	-2)	128,4	-2)	-2)
	Stainless steel R and high corrosion resistant steel HCR		50		-2)	13,9	-2)	29,4	47,1	-2)	80,3	-2)	-2)
			70		-2)	19,4	-2)	41,2	66,0	-2)	112,4	-2)	-2)
			80		-2)	22,2	-2)	47,1	75,4	-2)	128,4	-2)	-2)
Threaded rods, performance category C2 ¹⁾													
Characteristic resistance $V_{Rk,s,C2}$	Steel zinc plated	Property class	4.8	[kN]	-2)	13,3	-2)	26,3	41,1	-2)	59,3	-2)	-2)
			5.8		-2)	16,6	-2)	32,9	51,4	-2)	74,1	-2)	-2)
			8.8		-2)	22,2	-2)	43,9	68,6	-2)	98,8	-2)	-2)
	Stainless steel R and high corrosion resistant steel HCR		50		-2)	13,9	-2)	27,4	42,8	-2)	61,7	-2)	-2)
			70		-2)	19,4	-2)	38,4	60,0	-2)	86,4	-2)	-2)
			80		-2)	22,2	-2)	43,9	68,6	-2)	98,8	-2)	-2)

¹⁾ Partial factors for performance category C1 or C2 see table C42.1; for Anchor rods the factor for steel ductility is 1,0.

²⁾ No performance assessed.

Table C41.2: Characteristic resistance to steel failure under tension / shear loading for metric reinforcing bars (B500B) under seismic action performance category C1

Nominal diameter of the bar		ϕ	10	12	14	16	18	20	22	24	25	26	28	30	32
Characteristic resistance to steel failure under tension loading															
Reinforcing bar B500B acc. to DIN 488-2:2009-08, performance category C1 ¹⁾															
Characteristic resistance	$N_{Rk,s,C1}$ [kN]		42,3	61,0	83,1	108,5	137,1	169,5	205,2	244,0	265,1	286,2	332,6	381,2	434,1
Characteristic resistance to steel failure under shear loading, without lever arm															
Reinforcing bar B500B acc. to DIN 488-2:2009-08, performance category C1 ¹⁾															
Characteristic resistance	$V_{Rk,s,C1}$ [kN]		14,8	21,3	29,1	37,9	48,0	59,3	71,8	85,4	92,7	100,1	116,4	133,4	151,9

¹⁾ Partial factors for performance category C1 see table C42.1.

fischer Injection System FIS EM PLUS

Performance

Characteristic resistance to steel failure for metric Anchor rods / Threaded rods and reinforcing bars under seismic action performance category C2 and C1 respectively

Annex C41

Appendix 69 / 28

Table C42.1: Partial factors for metric Anchor rods, Threaded rods and reinforcing bars (B500B) under seismic action performance category C1 or C2

Anchor rod / Threaded rod		M10 to M30	
Nominal diameter of the bar ϕ		10 to 32	
Tension loading, steel failure ¹⁾			
Partial factor $\gamma_{Ms,N}$	Steel zinc plated	4.8	1,50
		5.8	1,50
		8.8	1,50
	Stainless steel R and high corrosion resistant steel HCR	50	2,86
		70	1,87 / Anchor rod HCR: 1,50 ²⁾
		80	1,60
	Reinforcing bar	B500B	1,40
Shear loading, steel failure ¹⁾			
Partial factor $\gamma_{Ms,V}$	Steel zinc plated	4.8	1,25
		5.8	1,25
		8.8	1,25
	Stainless steel R and high corrosion resistant steel HCR	50	2,38
		70	1,56 / Anchor rod HCR: 1,25 ²⁾
		80	1,33
	Reinforcing bar	B500B	1,50

¹⁾ In absence of other national regulations.

²⁾ Only admissible for high corrosion resistant steel HCR, acc. to Table A6.1.

fischer Injection System FIS EM PLUS

Performance

Partial factors for metric Anchor rods, Threaded rods, and reinforcing bars (B500B) under seismic action performance category C1 or C2

Annex C42

Appendix 70 / 28

Table C43.1: Characteristic resistance for combined pull-out and concrete failure for metric Anchor rods and Threaded rods in hammer drilled holes under seismic action performance category C1; working life 50 years

Anchor rod / Threaded rod		M10	M12	M14	M16	M20	M22	M24	M27	M30		
Characteristic bond resistance, combined pull-out and concrete cone failure												
Hammer-drilling with standard drill bit or hollow drill bit (dry or wet concrete)												
Tem- perature range	I: 24 °C / 40 °C	$\tau_{RK,C1}$	[N/mm ²]	7,0	7,0	6,7	6,0	5,7	6,7	6,7	6,7	
	II: 35 °C / 60 °C			7,0	7,0	6,7	6,0	5,7	6,7	6,7	6,7	6,7
	III: 50 °C / 72 °C			7,0	7,0	6,7	5,7	5,7	6,7	6,7	6,7	6,7
Hammer-drilling with standard drill bit or hollow drill bit (water filled hole)												
Tem- perature range	I: 24 °C / 40 °C	$\tau_{RK,C1}$	[N/mm ²]	7,5	7,5	6,5	5,7	5,7	5,7	5,7	5,7	
	II: 35 °C / 60 °C			7,5	7,5	6,5	5,7	5,7	5,7	5,7	5,7	5,7
	III: 50 °C / 72 °C			6,8	6,8	6,5	5,7	5,7	5,7	5,7	5,7	5,7
Installation factors												
Tension loading												
Dry or wet concrete		γ_{inst}	[-]	1,0								
Water filled hole				1,2				1,4				

Table C43.2: Characteristic resistance for combined pull-out and concrete failure for metric Anchor rods and Threaded rods in hammer drilled holes under seismic action performance category C1; working life 100 years

Anchor rod / Threaded rod		M10	M12	M14	M16	M20	M22	M24	M27	M30		
Characteristic bond resistance, combined pull-out and concrete cone failure												
Hammer-drilling with standard drill bit or hollow drill bit (dry or wet concrete)												
Tem- perature range	I: 24 °C / 40 °C	$\tau_{RK,C1}$	[N/mm ²]	5,5	5,3	5,8	4,6	4,6	5,4	5,3	5,1	
	II: 35 °C / 60 °C			5,5	5,3	5,8	4,6	4,6	5,4	5,3	5,1	5,0
	III: 50 °C / 72 °C			5,5	5,3	5,5	4,3	4,3	5,0	5,0	4,8	4,8
Hammer-drilling with standard drill bit or hollow drill bit (water filled hole)												
Tem- perature range	I: 24 °C / 40 °C	$\tau_{RK,C1}$	[N/mm ²]	5,9	5,6	5,7	4,3	4,6	4,6	4,5	4,3	
	II: 35 °C / 60 °C			5,9	5,6	5,7	4,3	4,6	4,6	4,5	4,3	4,2
	III: 50 °C / 72 °C			5,3	5,1	5,3	4,3	4,3	4,3	4,2	4,1	4,0
Installation factors												
Tension loading												
Dry or wet concrete		γ_{inst}	[-]	1,0								
Water filled hole				1,2				1,4				

fischer Injection System FIS EM PLUS

Performance

Characteristic resistance for combined pull-out and concrete failure under seismic action (C1) for Anchor rods / Threaded rods; working life 50 and 100 years

Annex C43

Appendix 71 / 28

Table C44.1: Characteristic resistance for combined pull-out and concrete failure for metric reinforcing bars in hammer drilled holes under seismic action performance category C1; working life 50 years

Nominal diameter of the bar		ϕ	10	12	14	16	18	20	22	24	25	26	28	30	32	
Characteristic bond resistance, combined pull-out and concrete cone failure																
Hammer-drilling with standard drill bit or hollow drill bit (dry or wet concrete)																
Tem- perature range	I: 24 °C / 40 °C	$\tau_{RK,C1}$	[N/mm ²]	7,0	7,0	6,7	5,7	5,7	5,7	6,7	6,7	6,7	6,7	6,7	4,8	
	II: 35 °C / 60 °C			7,0	7,0	6,7	5,7	5,7	5,7	6,7	6,7	6,7	6,7	6,7	6,7	4,8
	III: 50 °C / 72 °C			7,0	7,0	6,7	5,7	5,7	5,7	6,7	6,7	6,7	6,7	6,7	6,7	4,8
Hammer-drilling with standard drill bit or hollow drill bit (water filled hole)																
Tem- perature range	I: 24 °C / 40 °C	$\tau_{RK,C1}$	[N/mm ²]	7,5	6,5	6,5	5,7	5,7	5,7	5,7	5,7	5,7	5,7	5,7	4,8	
	II: 35 °C / 60 °C			7,5	6,5	6,5	5,7	5,7	5,7	5,7	5,7	5,7	5,7	5,7	4,8	
	III: 50 °C / 72 °C			6,5	6,5	5,8	5,8	5,7	5,7	5,7	5,7	5,7	5,7	5,7	5,7	4,8

Installation factors

Tension loading

Dry or wet concrete	γ_{inst}	[-]	1,0												
Water filled hole			1,2						1,4						

Table C44.2: Characteristic resistance for combined pull-out and concrete failure for metric reinforcing bars in hammer drilled holes under seismic action performance category C1; working life 100 years

Nominal diameter of the bar		ϕ	10	12	14	16	18	20	22	24	25	26	28	30	32	
Characteristic bond resistance, combined pull-out and concrete cone failure																
Hammer-drilling with standard drill bit or hollow drill bit (dry or wet concrete)																
Tem- perature range	I: 24 °C / 40 °C	$\tau_{RK,C1}$	[N/mm ²]	6,0	5,6	4,4	3,7	3,7	3,7	4,4	4,4	4,4	4,4	4,4	3,1	
	II: 35 °C / 60 °C			6,0	5,6	4,4	3,7	3,7	3,7	4,4	4,4	4,4	4,4	4,4	4,4	3,1
	III: 50 °C / 72 °C			6,0	5,6	4,4	3,7	3,7	3,7	4,4	4,4	4,4	4,4	4,4	4,4	3,1
Hammer-drilling with standard drill bit or hollow drill bit (water filled hole)																
Tem- perature range	I: 24 °C / 40 °C	$\tau_{RK,C1}$	[N/mm ²]	6,4	5,2	4,2	3,7	3,7	3,7	3,7	3,7	3,7	3,7	3,7	3,1	
	II: 35 °C / 60 °C			6,4	5,2	4,2	3,7	3,7	3,7	3,7	3,7	3,7	3,7	3,7	3,7	3,1
	III: 50 °C / 72 °C			5,5	5,2	3,8	3,8	3,7	3,7	3,7	3,7	3,7	3,7	3,7	3,7	3,1

Installation factors

Tension loading

Dry or wet concrete	γ_{inst}	[-]	1,0												
Water filled hole			1,2						1,4						

fischer Injection System FIS EM PLUS

Performance

Characteristic resistance for combined pull-out and concrete failure under seismic action (C1) for and reinforcing bars; working life 50 and 100 years

Annex C44

Appendix 72 / 28

Table C45.1: Characteristic resistance and Displacements for combined pull-out and concrete failure for metric Anchor rods and Threaded rods in hammer drilled holes under seismic action performance category C2; working life 50 and 100 years

Anchor rod / Threaded rod		M12	M16	M20	M24	
Characteristic bond resistance, combined pull-out and concrete cone failure						
Hammer-drilling with standard drill bit or hollow drill bit (dry or wet concrete)						
Tem- perature range	I: 24 °C / 40 °C	$\tau_{Rk,C2}$ [N/mm ²]	3,5	5,8	5,0	3,1
	II: 35 °C / 60 °C		3,5	5,8	5,0	3,1
	III: 50 °C / 72 °C		3,3	5,5	4,7	2,9
Hammer-drilling with standard drill bit or hollow drill bit (water filled hole)						
Tem- perature range	I: 24 °C / 40 °C	$\tau_{Rk,C2}$ [N/mm ²]	3,5	5,8	5,0	3,1
	II: 35 °C / 60 °C		3,5	5,8	5,0	3,1
	III: 50 °C / 72 °C		3,3	5,5	4,7	2,9
Installation factors						
Tension loading						
Dry or wet concrete	γ_{inst}	[-]	1,0			
Water filled hole			1,2	1,4		
Displacement-Factors for tension loading ¹⁾						
$\delta_{N,C2(50\%)-Factor}$	[mm/(N/mm ²)]	0,09	0,10	0,11	0,12	
$\delta_{N,C2(100\%)-Factor}$		0,15	0,17	0,17	0,18	
Displacement-Factors for shear loading ²⁾						
$\delta_{V,C2(50\%)-Factor}$	[mm/kN]	0,18	0,10	0,07	0,06	
$\delta_{V,C2(100\%)-Factor}$		0,25	0,14	0,11	0,09	
1) Calculation of effective displacement: $\delta_{N,C2(50\%)} = \delta_{N,C2(50\%)-Factor} \cdot \tau$ $\delta_{N,C2(100\%)} = \delta_{N,C2(100\%)-Factor} \cdot \tau$ τ = acting bond strength under tension loading			2) Calculation of effective displacement: $\delta_{V,C2(50\%)} = \delta_{V,C2(50\%)-Factor} \cdot V$ $\delta_{V,C2(100\%)} = \delta_{V,C2(100\%)-Factor} \cdot V$ V = acting shear loading			
fischer Injection System FIS EM PLUS					Annex C45 Appendix 73 / 28	
Performance Characteristic resistance for combined pull-out and concrete failure under seismic action (C2) for Anchor rods and Threaded rods; working life 50 and 100 years						

Table C46.1: Characteristic resistance to steel failure under tension or shear loading for fractional Threaded rods under seismic action performance category C1

Threaded rod		3/8"	1/2"	5/8"	3/4"	7/8"	1"	1 1/8"		
Characteristic resistance to steel failure under tension loading										
Threaded rods, performance category C1 ¹⁾										
Characteristic resistance $N_{Rk,s,C1}$	Steel zinc plated	F568M, Class 5.8	[kN]	25,0	45,7	72,9	107,9	148,9	195,4	246,0
		F1554, Grade 36		19,9	36,5	58,3	86,2	119,1	156,2	196,7
		F1554, Grade 55		25,8	47,3	75,3	111,5	154,0	202,0	254,4
		F1554, Grade 105		43,0	78,8	125,6	185,9	256,7	336,8	424,0
	Stainless steel R	A193, B7		43,0	78,8	125,6	185,9	256,7	336,8	424,0
		F593, Alloy Group 2		34,4	63,0	100,5	126,4	174,5	229,0	288,3
		A193, Grade B8M, Class 1		25,8	47,3	75,3	111,5	154,0	202,0	254,4
		A193, Grade B8M, Class 2B		32,7	59,9	95,4	141,3	195,1	255,9	322,2
Characteristic resistance to steel failure under shear loading without lever arm										
Threaded rods, performance category C1 ¹⁾										
Characteristic resistance $V_{Rk,s,C1}$	Steel zinc plated	F568M, Class 5.8	[kN]	12,0	21,9	34,9	51,7	53,6	70,3	88,5
		F1554, Grade 36		8,3	15,3	24,4	36,2	50,0	65,6	82,6
		F1554, Grade 55		10,3	18,9	30,1	44,6	46,2	60,6	76,3
		F1554, Grade 105		15,0	27,6	43,9	65,0	89,8	117,8	148,4
	Stainless steel R	A193, B7		17,2	31,5	50,2	74,3	77,0	101,0	127,2
		F593, Alloy Group 2		13,7	25,2	40,2	50,5	52,3	68,7	86,5
		A193, Grade B8M, Class 1		10,3	18,9	30,1	44,6	46,2	60,6	76,3
		A193, Grade B8M, Class 2B		13,1	23,9	38,1	56,5	58,5	76,7	96,6

¹⁾ Partial factors for performance category C1 or see table C48.1

fischer Injection System FIS EM PLUS

Performance

Characteristic resistance to steel failure under tension or shear loading for Anchor rods and Threaded rods under seismic action (performance category C1)

Annex C46

Appendix 74 / 28

Table C47.1: Characteristic resistance to **steel failure** under tension / shear loading for **fractional reinforcing bars** under seismic action performance category **C1**

Rebar size		#3	#4	#5	#6	#7	#8	#9	#10	
Characteristic resistance to steel failure under tension loading										
Reinforcing bar materials, performance category C1 ¹⁾										
Characteristic resistance $N_{Rk,S,C1}$	A615 (A767), Grade 40	[kN]	29,3	53,3	82,3	117,4	160,0	210,9	266,8	338,8
	A615 (A767), Grade 60		44,0	80,0	123,4	176,2	240,1	316,4	400,2	508,2
	A615 (A767), Grade 75		48,9	88,9	137,2	195,8	266,8	351,6	444,7	564,6
	A706 (A767), Grade 60		39,1	71,1	109,7	156,6	213,4	281,3	355,7	451,7
Characteristic resistance to steel failure under shear loading, without lever arm										
Reinforcing bar materials, performance category C1 ¹⁾										
Characteristic Resistance $V_{Rk,S,C1}$	A615 (A767), Grade 40	[kN]	13,0	23,6	36,5	52,1	71,0	93,6	118,4	150,4
	A615 (A767), Grade 60		16,3	29,6	45,6	65,2	88,8	117,0	148,0	188,0
	A615 (A767), Grade 75		18,1	32,9	50,7	72,4	98,7	130,1	164,5	208,9
	A706 (A767), Grade 60		14,4	26,3	40,6	57,9	78,9	104,0	131,6	167,1

¹⁾ Partial factors for performance category C1 see table C48.1.

fischer Injection System FIS EM PLUS

Performance

Characteristic resistance to steel failure under tension/shear loading for fractional reinforcing bars under seismic action (performance category C1)

Annex C47

Appendix 75 / 28

Table C48.1: Partial factors for fractional Threaded rods and reinforcing bars under seismic action performance category C1

Threaded rod		3/8" to 5/8"	3/4" to 1 1/8"	
Rebar size		#3 to #10		
Tension loading, steel failure ¹⁾				
Partial factor $\gamma_{Ms,N}$	Threaded rod, zinc plated	F568M, Class 5.8	1,50	
		F1554, Grade 36	1,94	
		F1554, Grade 55	1,64	
		F1554, Grade 105	1,43	
		A193, B7	1,43	
	Threaded rod, stainless steel R	F593, Alloy Group 2	1,85	2,27
		A193, Grade B8M, Class 1	[-] 3,00	
		A193, Grade B8M, Class 2B	1,52	
	Reinforcing bar	A615 (A767), Grade 40	1,80	
		A615 (A767), Grade 60	1,80	
		A615 (A767), Grade 75	1,60	
		A706 (A767), Grade 60	1,60	
Shear loading, steel failure ¹⁾				
Partial factor $\gamma_{Ms,V}$	Threaded rod, zinc plated	F568M, Class 5.8	1,25	
		F1554, Grade 36	1,61	
		F1554, Grade 55	1,36	
		F1554, Grade 105	1,50	
		A193, B7	1,50	
	Threaded rod, stainless steel R	F593, Alloy Group 2	1,54	1,89
		A193, Grade B8M, Class 1	[-] 2,50	
		A193, Grade B8M, Class 2B	1,27	
	Reinforcing bar	A615 (A767), Grade 40	1,50	
		A615 (A767), Grade 60	1,50	
		A615 (A767), Grade 75	1,33	
		A706 (A767), Grade 60	1,33	

¹⁾ In absence of other national regulations.

fischer Injection System FIS EM PLUS

Performance

Partial factors for Threaded rods and reinforcing bars under seismic action performance category C1 (fractional size)

Annex C48

Appendix 76 / 28

Table C49.1: Characteristic resistance for combined pull-out and concrete failure for fractional Threaded rods in hammer drilled holes under seismic action performance category C1; working life 50 years

Threaded rod		3/8"	1/2"	5/8"	3/4"	7/8"	1"	1 1/8"	
Characteristic bond resistance, combined pull-out and concrete cone failure									
Hammer-drilling with standard drill bit or hollow drill bit (dry or wet concrete)									
Tem- perature range	I: 24 °C / 40 °C	$\tau_{Rk,C1}$ [N/mm ²]	8,5	9,0	9,1	8,5	8,5	8,2	7,1
	II: 35 °C / 60 °C		8,5	9,0	9,1	8,5	8,5	8,2	7,1
	III: 50 °C / 72 °C		8,0	8,5	8,5	8,5	8,5	8,2	7,1
Hammer-drilling with standard drill bit or hollow drill bit (water filled hole)									
Tem- perature range	I: 24 °C / 40 °C	$\tau_{Rk,C1}$ [N/mm ²]	7,4	7,7	7,5	6,0	6,0	5,8	5,0
	II: 35 °C / 60 °C		7,4	7,7	7,5	6,0	6,0	5,8	5,0
	III: 50 °C / 72 °C		6,9	7,3	7,0	6,0	6,0	5,8	5,0
Installation factors									
Tension loading									
Dry or wet concrete		γ_{inst}	[-]	1,0					
Water filled hole				1,2		1,4			

Table C49.2: Characteristic resistance for combined pull-out and concrete failure for fractional Threaded rods in hammer drilled holes under seismic action performance category C1; working life 100 years

Threaded rod		3/8"	1/2"	5/8"	3/4"	7/8"	1"	1 1/8"	
Characteristic bond resistance, combined pull-out and concrete cone failure									
Hammer-drilling with standard drill bit or hollow drill bit (dry or wet concrete)									
Tem- perature range	I: 24 °C / 40 °C	$\tau_{Rk,C1}$ [N/mm ²]	6,8	6,8	6,9	6,9	6,8	6,3	5,3
	II: 35 °C / 60 °C		6,8	6,8	6,9	6,9	6,8	6,3	5,3
	III: 50 °C / 72 °C		6,4	6,4	6,5	6,4	6,4	5,9	5,1
Hammer-drilling with standard drill bit or hollow drill bit (water filled hole)									
Tem- perature range	I: 24 °C / 40 °C	$\tau_{Rk,C1}$ [N/mm ²]	5,9	5,9	5,7	4,9	4,8	4,4	3,7
	II: 35 °C / 60 °C		5,9	5,9	5,7	4,9	4,8	4,4	3,7
	III: 50 °C / 72 °C		5,5	5,5	5,3	4,5	4,5	4,2	3,6
Installation factors									
Tension loading									
Dry or wet concrete		γ_{inst}	[-]	1,0					
Water filled hole				1,2		1,4			

fischer Injection System FIS EM PLUS

Performance

Characteristic resist. for combined pull-out and concrete failure under seismic action (C1) for Anchor rods / Threaded rods; working life 50 and 100 years (fractional size)

Annex C49

Appendix 77 / 28

Table C50.1: Characteristic resistance for combined pull-out and concrete failure for fractional reinforcing bars in hammer drilled holes under seismic action performance category C1; working life 50 years

Rebar size		#3	#4	#5	#6	#7	#8	#9	#10 ¹⁾	
Characteristic bond resistance, combined pull-out and concrete cone failure										
Hammer-drilling with standard drill bit or hollow drill bit (dry or wet concrete)										
Tem- perature range	I: 24 °C / 40 °C	$\tau_{Rk,C1}$ [N/mm ²]	6,2	7,0	7,0	7,0	7,0	7,0	7,0	
	II: 35 °C / 60 °C		6,2	7,0	7,0	7,0	7,0	7,0	7,0	
	III: 50 °C / 72 °C		6,2	7,0	7,0	7,0	7,0	7,0	7,0	
Hammer-drilling with standard drill bit or hollow drill bit (water filled hole)										
Tem- perature range	I: 24 °C / 40 °C	$\tau_{Rk,C1}$ [N/mm ²]	6,6	5,7	5,7	5,3	5,3	5,3	5,3	4,4
	II: 35 °C / 60 °C		6,6	5,7	5,7	5,3	5,3	5,3	5,3	4,4
	III: 50 °C / 72 °C		5,7	5,7	5,3	5,3	5,3	5,3	5,3	4,4

Installation factors

Tension loading

Dry or wet concrete	γ_{inst}	[-]	1,0						
Water filled hole			1,2						1,4

¹⁾ Not allowed for drilling with hollow drill bit.

Table C50.2: Characteristic resistance for combined pull-out and concrete failure for fractional reinforcing bars in hammer drilled holes under seismic action performance category C1; working life 100 years

Rebar size		#3	#4	#5	#6	#7	#8	#9	#10 ¹⁾	
Characteristic bond resistance, combined pull-out and concrete cone failure										
Hammer-drilling with standard drill bit or hollow drill bit (dry or wet concrete)										
Tem- perature range	I: 24 °C / 40 °C	$\tau_{Rk,C1}$ [N/mm ²]	5,2	5,6	4,6	4,6	4,6	4,6	4,6	4,6
	II: 35 °C / 60 °C		5,2	5,6	4,6	4,6	4,6	4,6	4,6	4,6
	III: 50 °C / 72 °C		5,2	5,6	4,6	4,6	4,6	4,6	4,6	4,6
Hammer-drilling with standard drill bit or hollow drill bit (water filled hole)										
Tem- perature range	I: 24 °C / 40 °C	$\tau_{Rk,C1}$ [N/mm ²]	5,6	4,6	3,7	3,4	3,4	3,4	3,4	2,9
	II: 35 °C / 60 °C		5,6	4,6	3,7	3,4	3,4	3,4	3,4	2,9
	III: 50 °C / 72 °C		4,9	4,6	3,4	3,4	3,4	3,4	3,4	2,9

Installation factors

Tension loading

Dry or wet concrete	γ_{inst}	[-]	1,0						
Water filled hole			1,2						1,4

¹⁾ Not allowed for drilling with hollow drill bit.

fischer Injection System FIS EM PLUS	Annex C50 Appendix 78 / 28
Performance Characteristic resistance for combined pull-out and concrete failure under seismic action (C1) for and reinforcing bars; working life 50 and 100 years (fractional size)	

Table C51.1: Fire resistance to steel failure under tension and shear loading for metric Anchor rods and Threaded rods part 1

Fire resistance to steel failure under tension and shear loading						
Anchor rod / Threaded rod ISO 898-1 Class 5.8 and higher	R30			R60		
	$N_{Rk,s,fi,30}$ [kN]	$V_{Rk,s,fi,30}$ [kN]	$M^0_{Rk,s,fi,30}$ [Nm]	$N_{Rk,s,fi,60}$ [kN]	$V_{Rk,s,fi,60}$ [kN]	$M^0_{Rk,s,fi,60}$ [Nm]
M8	1,6	1,6	1,7	1,2	1,2	1,2
M10	3,3	3,3	4,2	2,3	2,3	3,0
M12	5,8	5,8	9,1	4,0	4,0	6,2
M14	6,6	6,6	12,0	4,6	4,6	8,4
M16	10,9	10,9	15,1	7,5	7,5	11,2
M20	11,1	11,1	29,4	8,2	8,2	21,8
M22	13,7	13,7	40,5	10,1	10,1	30,0
M24	16,0	16,0	50,9	11,8	11,8	37,7
M27	20,8	20,8	75,5	15,4	15,4	56,0
M30	25,4	25,4	102,0	18,8	18,8	75,6
Anchor rod / Threaded rod ISO 898-1 Class 5.8 and higher	R90			R120		
	$N_{Rk,s,fi,90}$ [kN]	$V_{Rk,s,fi,90}$ [kN]	$M^0_{Rk,s,fi,90}$ [Nm]	$N_{Rk,s,fi,120}$ [kN]	$V_{Rk,s,fi,120}$ [kN]	$M^0_{Rk,s,fi,120}$ [Nm]
M8	0,8	0,8	0,8	0,6	0,6	0,6
M10	1,4	1,4	1,8	0,9	0,9	1,1
M12	2,1	2,1	3,3	1,2	1,2	1,9
M14	2,7	2,7	4,9	1,7	1,7	3,2
M16	4,0	4,0	7,3	2,3	2,3	5,3
M20	5,3	5,3	14,2	3,9	3,9	10,4
M22	6,6	6,6	19,5	4,8	4,8	14,3
M24	7,7	7,7	24,6	5,6	5,6	18,0
M27	10,0	10,0	36,4	7,3	7,3	26,7
M30	12,3	12,3	49,3	9,0	9,0	36,1

fischer Injection System FIS EM PLUS

Performance

Fire resistance to steel failure under tension and shear loading for metric Anchor rods and Threaded rods part 1

Annex C51

Appendix 79 / 28

Table C52.1: Fire resistance to steel failure under tension and shear loading for metric Anchor rods and Threaded rods part 2

Anchor rods R and HCR and Threaded rod, EN ISO 3506-1 Class A4-50 and higher	R30			R60		
	$N_{Rk,s,fi,30}$ [kN]	$V_{Rk,s,fi,30}$ [kN]	$M^0_{Rk,s,fi,30}$ [Nm]	$N_{Rk,s,fi,60}$ [kN]	$V_{Rk,s,fi,60}$ [kN]	$M^0_{Rk,s,fi,60}$ [Nm]
M8	0,7	0,7	0,7	0,5	0,5	0,6
M10	1,4	1,4	1,8	1,1	1,1	1,5
M12	2,5	2,5	3,9	2,1	2,1	3,9
M14	3,4	3,4	6,2	2,8	2,8	6,2
M16	4,7	4,7	9,9	3,9	3,9	9,9
M20	7,3	7,3	19,4	6,1	6,1	19,4
M22	9,0	9,0	26,7	7,5	7,5	26,7
M24	10,5	10,5	33,6	8,8	8,8	28,0
M27	13,7	13,7	49,9	11,4	11,4	41,6
M30	16,8	16,8	67,4	14,0	14,0	56,2
Anchor rods R and HCR and Threaded rod, EN ISO 3506-1 Class A4-50 and higher	R90			R120		
	$N_{Rk,s,fi,90}$ [kN]	$V_{Rk,s,fi,90}$ [kN]	$M^0_{Rk,s,fi,90}$ [Nm]	$N_{Rk,s,fi,120}$ [kN]	$V_{Rk,s,fi,120}$ [kN]	$M^0_{Rk,s,fi,120}$ [Nm]
M8	0,4	0,4	0,4	0,3	0,3	0,3
M10	0,9	0,9	1,2	0,8	0,8	1,0
M12	1,6	1,6	3,9	1,3	1,3	3,9
M14	2,3	2,3	6,2	1,8	1,8	6,2
M16	3,1	3,1	9,9	2,5	2,5	9,9
M20	4,9	4,9	19,4	3,9	3,9	19,4
M22	6,0	6,0	26,7	4,8	4,8	26,7
M24	7,0	7,0	22,4	5,6	5,6	17,9
M27	9,1	9,1	33,2	7,3	7,3	26,6
M30	11,2	11,2	44,9	8,9	8,9	35,9

fischer Injection System FIS EM PLUS

Performance

Fire resistance to steel failure under tension and shear loading for metric Anchor rods and Threaded rods part 2

Annex C52

Appendix 80 / 28

Table C53.1: Fire resistance to steel failure under tension and shear loading for fractional Threaded rods

Fire resistance to steel failure under tension and shear loading						
Threaded rod	R30			R60		
Steel zinc plated; detailed materials see Table A7.1, part No 2 ¹⁾	$N_{Rk,s,fi,30}$ [kN]	$V_{Rk,s,fi,30}$ [kN]	$M^0_{Rk,s,fi,30}$ [Nm]	$N_{Rk,s,fi,60}$ [kN]	$V_{Rk,s,fi,60}$ [kN]	$M^0_{Rk,s,fi,60}$ [Nm]
3/8"	2,7	2,7	3,2	1,9	1,9	2,3
1/2"	5,9	5,9	9,6	4,1	4,1	6,7
5/8"	6,7	6,7	13,7	4,9	4,9	10,1
3/4"	9,7	9,7	24,3	7,2	7,2	18,0
7/8"	13,5	13,5	39,4	10,0	10,0	29,2
1"	17,7	17,7	59,3	13,1	13,1	43,9
1 1/8"	22,3	22,3	83,8	16,5	16,5	62,2
Threaded rod	R90			R120		
Steel zinc plated; detailed materials see Table A7.1, part No 2 ¹⁾	$N_{Rk,s,fi,90}$ [kN]	$V_{Rk,s,fi,90}$ [kN]	$M^0_{Rk,s,fi,90}$ [Nm]	$N_{Rk,s,fi,120}$ [kN]	$V_{Rk,s,fi,120}$ [kN]	$M^0_{Rk,s,fi,120}$ [Nm]
3/8"	1,1	1,1	1,4	0,8	0,8	0,9
1/2"	2,3	2,3	3,7	1,3	1,3	2,2
5/8"	3,6	3,6	7,5	2,2	2,2	4,5
3/4"	4,7	4,7	11,7	3,4	3,4	8,6
7/8"	6,5	6,5	19,0	4,7	4,7	13,9
1"	8,5	8,5	28,6	6,2	6,2	20,9
1 1/8"	10,7	10,7	40,5	7,9	7,9	29,6
Threaded rod	R30			R60		
Stainless steel R; detailed materials see Table A7.1, part No 2	$N_{Rk,s,fi,30}$ [kN]	$V_{Rk,s,fi,30}$ [kN]	$M^0_{Rk,s,fi,30}$ [Nm]	$N_{Rk,s,fi,60}$ [kN]	$V_{Rk,s,fi,60}$ [kN]	$M^0_{Rk,s,fi,60}$ [Nm]
3/8"	1,1	1,1	1,4	0,9	0,9	1,1
1/2"	2,7	2,7	4,4	2,2	2,2	3,7
5/8"	4,3	4,3	8,9	3,6	3,6	7,4
3/4"	6,4	6,4	16,1	5,4	5,4	13,4
7/8"	8,9	8,9	26,1	7,4	7,4	21,7
1"	11,7	11,7	39,2	9,7	9,7	32,6
1 1/8"	14,7	14,7	55,4	12,3	12,3	46,2
Threaded rod	R90			R120		
Stainless steel R; detailed materials see Table A7.1, part No 2	$N_{Rk,s,fi,90}$ [kN]	$V_{Rk,s,fi,90}$ [kN]	$M^0_{Rk,s,fi,90}$ [Nm]	$N_{Rk,s,fi,120}$ [kN]	$V_{Rk,s,fi,120}$ [kN]	$M^0_{Rk,s,fi,120}$ [Nm]
3/8"	0,7	0,7	0,9	0,6	0,6	0,7
1/2"	1,8	1,8	2,9	1,4	1,4	2,3
5/8"	2,9	2,9	5,9	2,3	2,3	4,7
3/4"	4,3	4,3	10,7	3,4	3,4	8,5
7/8"	5,9	5,9	17,4	4,7	4,7	13,9
1"	7,8	7,8	26,1	6,2	6,2	20,9
1 1/8"	9,8	9,8	36,9	7,8	7,8	29,5

¹⁾ No performance assessed for ASTM F1554 Grade 36.

fischer Injection System FIS EM PLUS

Performance

Fire resistance to steel failure under tension and shear loading for fractional Threaded rods

Annex C53

Appendix 81 / 28

Characteristic bond resistance for cracked concrete under fire conditions for metric and fractional Anchor rods and Threaded rods in hammer drilled holes with standard drill bit or hollow drill bit

The characteristic bond resistance for cracked concrete under fire conditions for a given temperature.

$\tau_{Rk,fi}(\theta)$ has to be calculated by the following equation:

$$\tau_{Rk,fi}(\theta) = k_{fi,p}(\theta) \cdot \tau_{Rk,cr,C20/25}$$

- θ = Temperature in °C in the mortar layer,
- $\tau_{Rk,fi}(\theta)$ = Characteristic bond resistance for cracked concrete under fire exposure for a given temperature in N/mm² for concrete classes C20/25 to C50/60.
- $k_{fi,p}(\theta)$ = Reduction factor under fire conditions.
- $\tau_{Rk,cr,C20/25}$ = Characteristic bond resistance for cracked concrete C20/25 in N/mm², given in Table C6.1, Table C7.1, Table C29.1 to Table C31.1, respectively.

Anchor rods or Threaded rods	If: $\theta > 21 \text{ °C}$ If: $\theta > \theta_{max} = 284 \text{ °C}$	$k_{fi,p}(\theta) = 26,71 \cdot \theta^{-1,166} \leq 1,0$ $k_{fi,p}(\theta) = 0$	see Figure C54.1
---------------------------------	--	---	------------------

Figure C54.1: Graph of reduction factor $k_{fi,p}(\theta)$ for Anchor rods or Threaded rods.

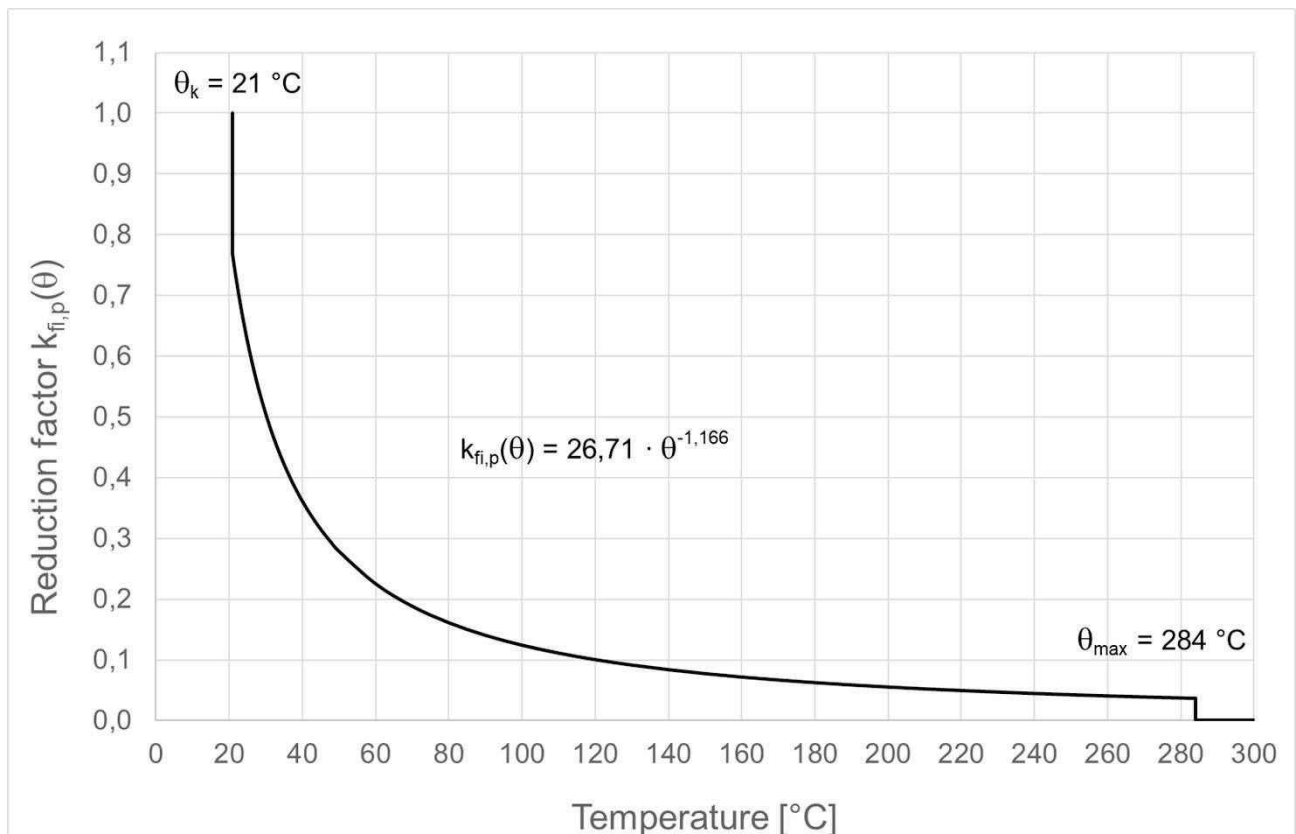

fischer Injection System FIS EM PLUS

Performance

Characteristic bond resistance under fire conditions for anchor rods and threaded rods

Annex C54

Appendix 82 / 28