

## DECLARAÇÃO DE DESEMPENHO

### DoP 0199

para ancoragem dinâmica fischer FDA (Âncoras químicas para utilização em betão)

PT

1. <u>Código de identificação único do produto-tipo:</u>	<b>DoP 0199</b>
2. <u>Utilização(ões) prevista(s):</u>	<b>Fixações pós-instalados para uso em betão sob carga cíclico de fadiga</b>
3. <u>Fabricante:</u>	<b>Ver anexos, especialmente anexos B1- B6 fischerwerke GmbH &amp; Co. KG, Otto-Hahn-Straße 15, 79211 Denzlingen, Alemanha</b>
4. <u>Representante autorizado:</u>	–
5. <u>Sistema(s) de avaliação e verificação da regularidade do desempenho (AVCP):</u>	1
6. <u>Documento de Avaliação Europeu:</u> Avaliação Técnica Europeia: Organismo de Avaliação Técnica: Organismo(s) notificado(s):	<b>EAD 330250-00-0601, Edition 09/2019 ETA-20/0206; 2020-06-29 DIBt- Deutsches Institut für Bautechnik 2873 TU Darmstadt</b>
7. <u>Desempenho(s) declarado(s):</u> <b>Resistência mecânica e estabilidade (BWR 1)</b> Resistência característica à fadiga sob carga de tração cíclica (Método de Avaliação A)	Resistência característica à fadiga do aço: Anexos C1, C3  Resistência característica à fadiga por cone de betão e por fendilhação: Anexos C1, C3  Resistência característica à fadiga por rotura combinada por arranque e cone de betão para ancoragens químicas: Anexos C1, C3
Resistência característica à fadiga sob carga de corte cíclica (Método de Avaliação A)	Resistência característica à fadiga do aço: Anexos C2, C3  Resistência característica à fadiga por rotura do bordo de betão: Anexos C2, C3  Resistência característica à fadiga do betão ao destacamento (pry-out): Anexos C2, C3
Resistência característica à fadiga sob cargas combinadas de tração e corte cíclicas (Método de Avaliação A):	Resistência característica à fadiga do aço: Anexos C1, C2, C3
Fator de transferência de carga para tração e corte cíclico (Método de Avaliação A)	Fator de transferência de carga: Anexos C1, C2, C3
8. <u>Documentação Técnica Adequada e/ou Documentação Técnica Específica:</u>	–

O desempenho do produto identificado acima está em conformidade com o conjunto de desempenhos declarados. A presente declaração de desempenho é emitida, em conformidade com o Regulamento (UE) n.º 305/2011, sob a exclusiva responsabilidade do fabricante identificado acima.

Assinado por e em nome do fabricante por:



Dr. Oliver Geibig, Diretor Administrativo de Unidades de Negócios e Engenharia  
Tumlingen, 2021-03-16



Jürgen Grün, Diretor Administrativo de Química e Qualidade

Este DoP foi preparado em diferentes línguas. Em caso de litígio sobre a interpretação, a versão em inglês prevalecerá sempre.

O Anexo inclui informações voluntárias e complementares em inglês que excedem os requisitos legais (linguisticamente especificados).

## Specific Part

### 1 Technical description of the product

The fischer Dynamic-Anchor FDA is a bonded expansion anchor consisting of a cartridge with injection mortar fischer FIS HB, a fischer Anchor rod FDA-A with a centering sleeve, a washer, a hexagon nut and a lock nut.

The load transfer is realised by mechanical interlock of several cones in the bonding mortar and then via a combination of bonding and friction forces in the base material (concrete).

The product description is given in Annex A.

### 2 Specification of the intended use in accordance with the applicable European Assessment Document

The performances given in Section 3 are only valid if the anchor is used in compliance with the specifications and conditions given in Annex B.

The verifications and assessment methods on which this European Technical Assessment is based lead to the assumption of a working life of the anchor of at least 50 years. The indications given on the working life cannot be interpreted as a guarantee given by the producer, but are to be regarded only as a means for choosing the right products in relation to the expected economically reasonable working life of the works.

### 3 Performance of the product and references to the methods used for its assessment

#### 3.1 Mechanical resistance and stability (BWR 1)

Essential characteristic	Performance
Characteristic fatigue resistance under cyclic tension loading (Assessment method A)	
Characteristic steel fatigue resistance	See Annexes C1 and C3
Characteristic concrete cone and splitting fatigue resistance	
Characteristic combined pull- out /concrete cone fatigue resistance	
Characteristic fatigue resistance under cyclic shear loading (Assessment method A)	
Characteristic steel fatigue resistance	See Annexes C2 and C3
Characteristic concrete edge fatigue resistance	
Characteristic concrete pry out fatigue resistance	

Essential characteristic	Performance
Characteristic fatigue resistance under cyclic combined tension and shear loading (Assessment method A)	
Characteristic steel fatigue resistance	See Annexes C1 to C3
Load transfer factor for cyclic tension and shear loading	
Load transfer factor	See Annexes C1 to C3

**4 Assessment and verification of constancy of performance (AVCP) system applied, with reference to its legal base**

In accordance with European Assessment Document No. 330250-00-0601, the applicable European legal act is: [96/582/EC].

The system to be applied is: 1

## Installation conditions

fischer Dynamic-Anchor FDA

Push through installation

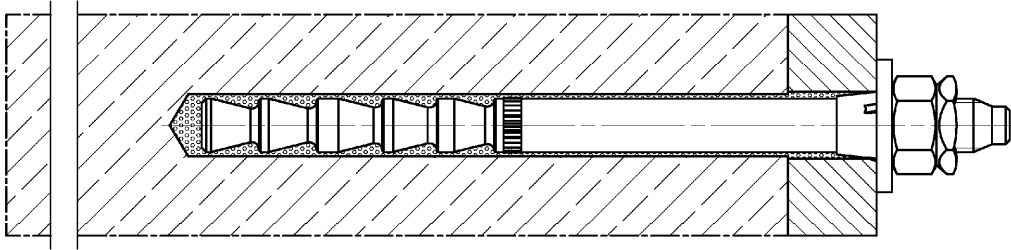

Pictures not to scale

fischer Dynamic-Anchor FDA

**Product description**  
Installation conditions

**Annex A 1**

Appendix 3 / 16

## Overview system components part 1

### Injection cartridge (shuttle cartridge) with sealing cap

Size: 345 ml, 350 ml, 360 ml, 390 ml, 585 ml, 1500 ml

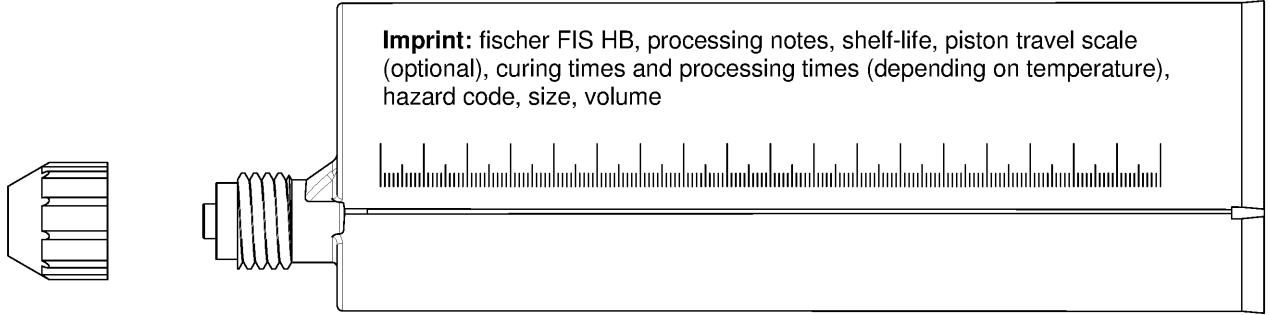

### Injection cartridge (coaxial cartridge) with sealing cap

Size: 150 ml, 200 ml, 300 ml, 400 ml, 410 ml

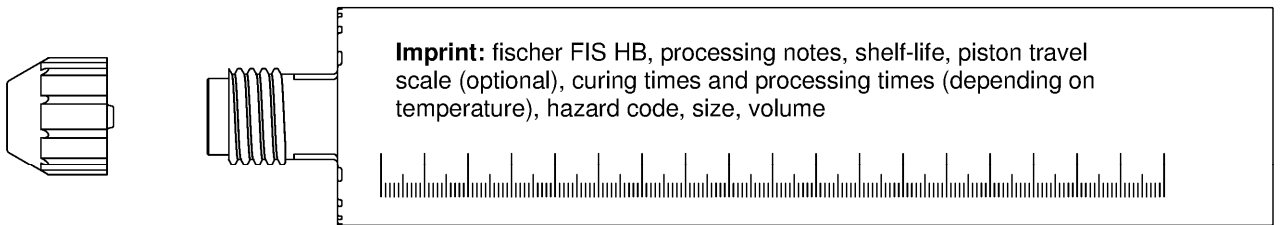

### Static mixer FIS MR Plus for injection cartridges up to 410 ml

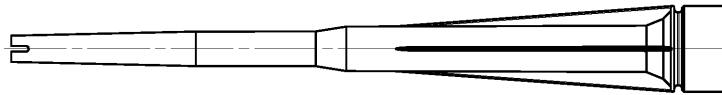

### Static mixer FIS UMR for injection cartridges from 585 ml

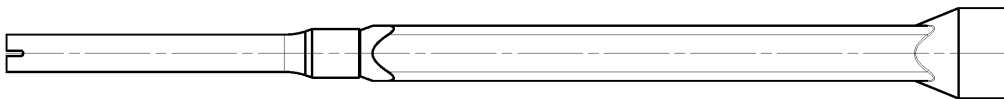

### Injection adapter and extension tube Ø 9 for static mixer FIS MR Plus; Injection adapter and extension tube Ø 9 or Ø 15 for static mixer FIS UMR

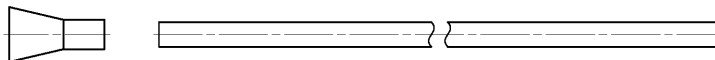

Pictures not to scale

fischer Dynamic-Anchor FDA

#### Product description

Overview system components part 1;  
cartridges / static mixer / injection adapter

**Annex A 2**

Appendix 4 / 16

## Overview system components part 2

fischer Dynamic-Anchor FDA

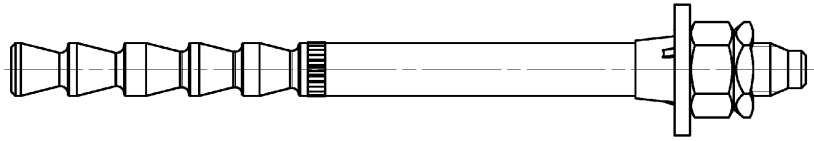

fischer anchor rod FDA-A; Size: M12, M16

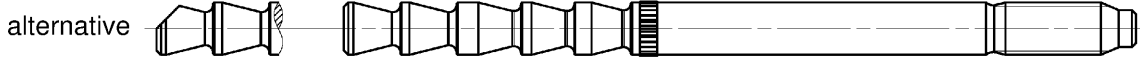

centering sleeve

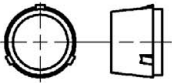

washer

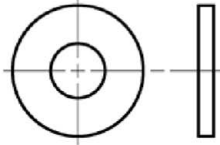

hexagon nut

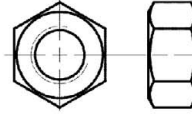

lock nut

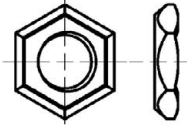

Cleaning brush BS

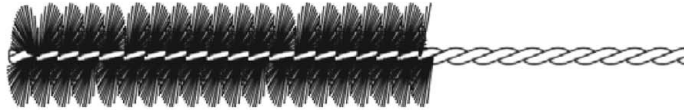

Blow-out pump ABP with cleaning nozzle or ABG



Pictures not to scale

fischer Dynamic-Anchor FDA

### Product description

Overview system components part 2;  
Steel components / cleaning brush / blow-out pump

**Annex A 3**

Appendix 5 / 16

**Table A4.1: Dimensions system components**

Designation		FDA 12x100	FDA 16x125
Thread	[-]	M12	M16
Anchor rod	d	12	16,5
	L <sub>min</sub>	135	168
	L <sub>max</sub>	330	362
Centering sleeve	D <sub>z</sub>	11,8	16,3
	L <sub>z</sub>	11	13
Washer	≥ d <sub>a</sub>	30	40
	t <sub>s,min</sub>	3,5	4
	t <sub>s,max</sub>	7	8

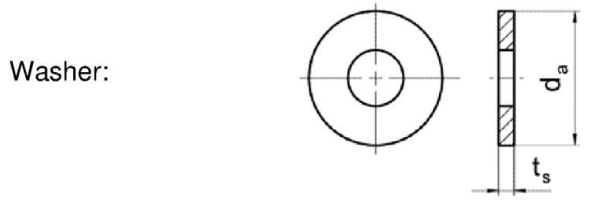
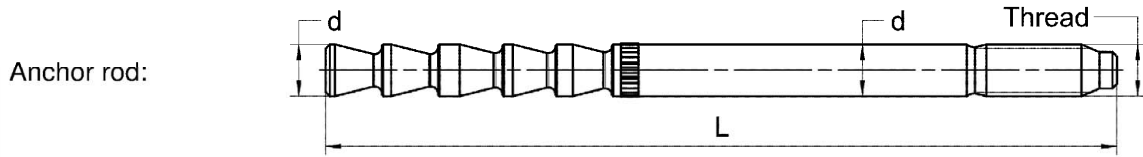

Pictures not to scale

fischer Dynamic-Anchor FDA

**Product description**  
Dimensions system components

**Annex A 4**  
Appendix 6 / 16

**Table A5.1: Materials**

<b>Part</b>	<b>Designation</b>	<b>Material</b>
1	Injection cartridge	Mortar, hardener, filler
	Steel grade	Steel, zinc plated
2	fischer anchor rod FDA-A	Property class 8.8; EN ISO 898-1:2013 zinc plated $\geq 5 \mu\text{m}$ , EN ISO 4042: 2018/Zn5/An(A2K) $f_{uk} \leq 1000 \text{ N/mm}^2$ $A_5 > 12 \%$ fracture elongation coated
3	Centering sleeve	Plastic
4	Washer	zinc plated $\geq 5 \mu\text{m}$ , EN ISO 4042: 2018/Zn5/An(A2K)
5	Hexagon nut	Property class 8; EN ISO 898-2:2012 zinc plated $\geq 5 \mu\text{m}$ , ISO 4042: 2018/Zn5/An(A2K)
6	Lock nut	zinc plated $\geq 5 \mu\text{m}$ , EN ISO 4042: 2018/Zn5/An(A2K)



fischer Dynamic-Anchor FDA

**Product description**  
Materials**Annex A 5**  
Appendix 7 / 16

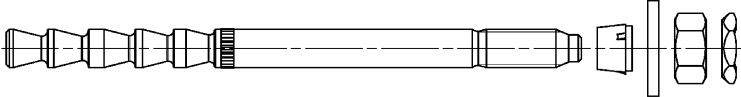

# Specifications of intended use (part 1)

**Table B1.1:** Overview use and performance categories

		fischer Dynamic-Anchor FDA
		
Hammer drilling with standard drill bit		Nominal drill bit diameter ( $d_0$ ) 14 mm and 18 mm
Hammer drilling with hollow drill bit (fischer "FHD", Heller "Duster Expert"; Bosch "Speed Clean"; Hilti "TE-CD, TE-YD"; DreBo „D-Plus“; DreBo „D-Max“)		
Fatigue load, in	uncracked concrete cracked concrete	M12 and M16
Design method I acc. to TR061		Number of load cycles $n = 1$ to $n = \infty$
Design method II acc. to TR061		Number of load cycles $n = \infty$
Use category I1	dry or wet concrete	M12 and M16
Installation direction		D3 Downwards, horizontal and upwards (overhead) installation
Installation method		push through installation
Installation temperature		FIS HB: $T_{i,min} = -5\text{ °C}$ to $T_{i,max} = +40\text{ °C}$
In-service temperature range I:		$-40\text{ °C}$ to $+80\text{ °C}$ (max. short term temperature $+80\text{ °C}$ ; max. long term temperature $+50\text{ °C}$ )

fischer Dynamic-Anchor FDA

**Intended use**  
Specifications (part 1)

**Annex B 1**

Appendix 8 / 16

## Specifications of intended use (part 2)

### **Anchorage subject to:**

- Fatigue cycling load  
Note:  
static and quasi-static load according to EN 1992-4:2018 and ETA-06/0171 (FDA corresponds to FHB)

### **Base materials:**

- Compacted reinforced or unreinforced normal weight concrete without fibers of strength classes C20/25 to C50/60 according to EN 206:2013+A1:2016

### **Use conditions (Environmental conditions):**

- Structures subject to dry internal conditions (zinc plated steel)

### **Design:**

- Anchorages have to be designed by a responsible engineer with experience of concrete anchor design.
- Verifiable calculation notes and drawings are to be prepared taking account of the loads to be anchored. The position of the anchor is indicated on the design drawings (e. g. position of the anchor relative to reinforcement or to supports).
- Anchorages are designed in accordance with:
  - EN 1992-4:2018 and
  - EOTA Technical Report TR 061 "Design method for fasteners in concrete under fatigue cyclic loading", edition January 2013
- Fastening in stand-off installation or with a grout layer is not covered by this European Technical Assessment (ETA)

### **Installation:**

- Anchor installation is to be carried out by appropriately qualified personnel and under the supervision of the person responsible for technical matters of the site
- In case of aborted hole: The hole shall be filled with mortar
- In case of pure tensile load, the area between anchor and fixture (annular gap) does not have to be filled.
- Overhead installation is allowed

fischer Dynamic-Anchor FDA

**Intended use**  
Specifications (part 2)

**Annex B 2**  
Appendix 9 / 16

**Table B3.1:** Installation parameters for fischer Dynamic-Anchor FDA

Designation		FDA 12x100		FDA 16x125	
Thread		M12		M16	
Width across flats	SW	19		24	
Nominal drill hole diameter	d <sub>0</sub>	14		18	
Drill hole depth	h <sub>0,min</sub>	105		130	
Effective embedment depth	h <sub>ef</sub>	100		125	
Minimum thickness of concrete member	h <sub>min</sub>	130	200	160	250
Minimum spacing	s <sub>min</sub>	100	100	100	100
Minimum edge distance	c <sub>min</sub>	200	100	200	100
For h <sub>min</sub> ≤ h ≤ 2h <sub>ef</sub> :	s <sub>1</sub> ≥ s <sub>min</sub> = 100 mm c <sub>1</sub> ≥ c <sub>min</sub> = 100 mm	[mm] [(3 • c <sub>1</sub> + s <sub>1</sub> ) • h] ≥ 88000			
Calculation C <sub>req</sub> : s <sub>1</sub> and h available		C <sub>req</sub> ≥ (88000/h – s <sub>1</sub> ) / 3			
Calculation s <sub>req</sub> : c <sub>1</sub> and h available		s <sub>req</sub> ≥ 88000/h – 3 • c <sub>1</sub>			
Diameter of the clearance hole of the fixture	d <sub>f</sub>	15		19	
Thickness of fixture	t <sub>fix,min</sub>	12		16	
	t <sub>fix,max</sub>	200			
Installation torque	T <sub>inst</sub>	[Nm] 40		60	

**fischer anchor rod FDA-A**

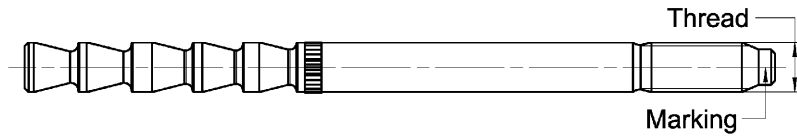

**Marking fischer anchor rod:**

work symbol, thread diameter, embedment depth, intended use e.g.: 16 x 125 dyn

**Installation conditions:**

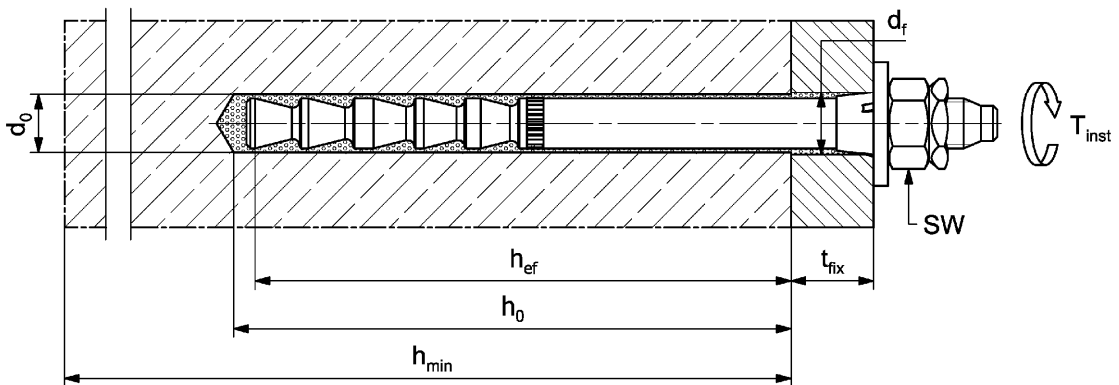

Figures not to scale

fischer Dynamic-Anchor FDA

**Intended use**  
Installation parameters fischer Dynamic-Anchor FDA

**Annex B 3**

Appendix 10 / 16

**Table B4.1:** Parameters of the cleaning brush BS (steel brush with steel bristles)

The size of the cleaning brush refers to the drill hole diameter

Nominal drill hole diameter	$d_b$	[mm]	14	18
Steel brush diameter	$d_b$		16	20

**Table B4.2:** Processing time  $t_{work}$  and curing time  $t_{cure}$  (FIS HB)

(During the curing time of the mortar the concrete temperature may not fall below the listed minimum temperature. Minimal cartridge temperature +5 °C)

Temperature at anchoring base [°C]	Maximum processing time $t_{work}$	Minimum curing time <sup>1)</sup> $t_{cure}$
-5 to 0	---	6 h
> 0 to 5	---	3 h
> 5 to 10	15 min	90 min
> 10 to 20	6 min	35 min
> 20 to 30	4 min	20 min
> 30 to 40	2 min	12 min

<sup>1)</sup> In wet concrete the curing times must be doubled.

fischer Dynamic-Anchor FDA

**Intended use**

Parameters of the cleaning brush (steel brush); Processing time and curing time

**Annex B 4**

Appendix 11 / 16

# Installation instructions Dynamic-Anchor FDA part 1; push through installation

## Drilling and cleaning the hole (hammer drilling with standard drill bit)

1

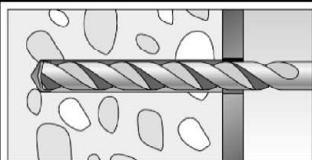

Drill the hole.  
Nominal drill hole diameter  $d_0$  and drill hole depth  $h_0$   
see **table B3.1**

2

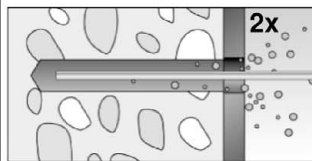

Clean the drill hole.  
Blow out the drill hole twice by hand or  
with oil-free compressed air (> 6 bar).



3

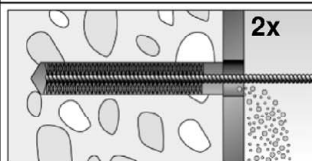

Brush the drill hole twice with steel brush.  
Corresponding brushes see **table B4.1**

4

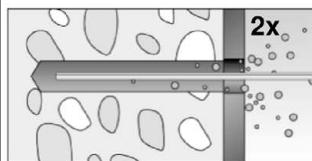

Clean the drill hole.  
Blow out the drill hole twice by hand or  
with oil-free compressed air (> 6 bar).



Go to step 5 (Annex B 6)

## Drilling and cleaning the hole (hammer drilling with hollow drill bit)

1



Check a suitable hollow drill (see **table B1.1**)  
for correct operation of the dust extraction

2

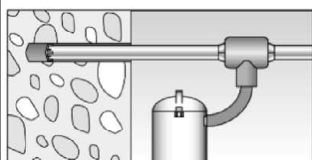

Use a suitable dust extraction system, e. g. fischer FVC 35 M or a comparable  
dust extraction system with equivalent performance data.  
Drill the hole with hollow drill bit. The dust extraction system has to extract the  
drill dust nonstop during the drilling process and must be adjusted to  
maximum power.  
Nominal drill hole diameter  $d_0$  and drill hole depth  $h_0$  see **table B3.1**

Go to step 5 (Annex B 6)

fischer Dynamic-Anchor FDA



**Intended use**  
Installation instructions Dynamic-Anchor FDA part 1; push through installation

**Annex B 5**

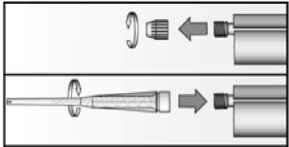
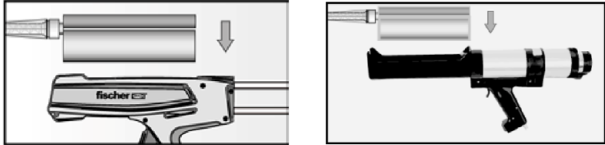

Appendix 12 / 16

# Installation instructions Dynamic-Anchor FDA part 2; push through installation

## Preparing the cartridge

5		<p>Remove the sealing cap</p> <p>Screw on the static mixer (the spiral in the static mixer must be clearly visible)</p>
6		<p>Place the cartridge into the dispenser</p>
7		<p>Extrude approximately 10 cm of material out until the resin is evenly grey in colour.</p> <p>Do not use mortar that is not uniformly grey</p>

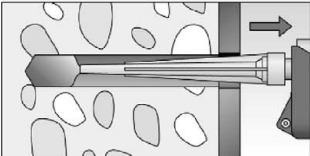
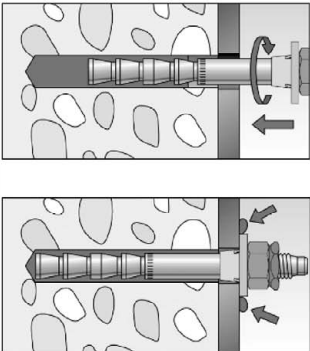
## Installation Dynamic-Anchor

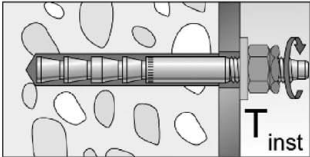
8		<p>Fill approximately 2/3 of the drill hole incl. fixture with mortar. Always begin from the bottom of the hole and avoid bubbles.</p> <p>For drill hole depth <math>\geq 150</math> mm use an extension tube. For overhead installation, deep holes <math>h_0 &gt; 250</math> mm use an injection-adapter.</p>
9		<p>Push the pre-assembled fischer anchor rod (with centering sleeve, washer, hexagon nut and lock nut) into the drill hole until the washer is in full contact with the surface, turning it slightly while doing so. Gently hammer the anchor to the setting depth.</p> <p>Ensure the correct position of the metal parts and the centering sleeve.</p> <p>Only use clean and oil-free metal parts.</p>
10		<p>Wait for the specified curing time <math>t_{cure}</math> see <b>table B4.2</b></p>
11		<p>Tighten the hexagon nut with installation torque <math>T_{inst}</math> (see <b>table B3.1</b>). Tighten lock nut manually, then use wrench to give another quarter to half turn.</p>

fischer Dynamic-Anchor FDA

### Intended use

Installation instructions Dynamic-Anchor FDA part 2; push through installation

**Annex B 6**

Appendix 13 / 16

**Table C1.1:** Resistance to tension fatigue load;  
Assessment method A; (**Design method I** according to **TR 061**)

fischer Dynamic-Anchor FDA		12x100	16x125
<b>Tension load capacity, steel failure</b>			
Characteristic steel fatigue resistance		$\Delta N_{Rk,s,0,n}$	
	[kN]		
Number of load cycles	n		
	1	44,0	82,0
	$\leq 10^3$	42,0	79,5
	$\leq 3 \cdot 10^3$	39,9	76,2
	$\leq 10^4$	36,0	69,7
	$\leq 3 \cdot 10^4$	31,1	60,6
	$\leq 10^5$	25,0	48,2
	$\leq 3 \cdot 10^5$	20,0	37,3
	$\leq 10^6$	16,5	29,2
$> 10^6$	14,6	25,0	
Partial factor	$\gamma_{Mc,N,fat}$	[-] according to TR 061, Eq. (3)	
<b>Tension load capacity, concrete cone failure, concrete splitting and pull out</b>			
Characteristic fatigue resistance for concrete cone failure, concrete splitting and pull out			
Effective embedment depth	$h_{ef}$	[mm]	
		100	125
Reduction factor <sup>1)</sup>		[-] $\eta_{k,c,N,fat,n} / \eta_{k,sp,N,fat,n} / \eta_{k,p,N,fat,n}$	
Number of load cycles	n		
	1		1,00
	$\leq 10^3$		0,88
	$\leq 3 \cdot 10^3$		0,83
	$\leq 10^4$		0,77
	$\leq 3 \cdot 10^4$		0,73
	$\leq 10^5$		0,69
	$\leq 3 \cdot 10^5$		0,66
	$\leq 10^6$		0,65
$> 10^6$		0,64	
Partial factor	$\gamma_{Mc/sp/p,fat}$	1,50	
Load-transfer factor	$\psi_{FN}$	0,78	
Exponent for combined load	$\alpha_{sn}$	0,81	1,08
Exponent for combined load	$\alpha_c$	1,50	

<sup>1)</sup>  $\Delta N_{Rk,c,0,n} = \eta_{k,c,N,fat,n} \cdot N_{Rk,c}$  with  $N_{Rk,c}$  acc. to EN 1992-4:2018 (with  $N_{Rk,c}^0$  with  $k_{cr,N} = 7,7$  and  $k_{ucr,N} = 11,0$ )

$\Delta N_{Rk,sp,0,n} = \eta_{k,sp,N,fat,n} \cdot N_{Rk,sp}$  with  $N_{Rk,sp}$  acc. to EN 1992-4:2018 (with  $N_{Rk,sp}^0 = \min(N_{Rk,p}; N_{Rk,c}^0)$ )

$\Delta N_{Rk,p,0,n} = \eta_{k,p,N,fat,n} \cdot N_{Rk,p}$  with  $N_{Rk,p}$  acc. to ETA-06/0171

Anchor FDA 12 x 100 corresponds to the anchor FHB-A 12 x 100 in ETA-06/0171 for the design under static and quasi-static load

Anchor FDA 16 x 125 corresponds to the anchor FHB-A 16 x 125 in ETA-06/0171 for the design under static and quasi-static load

fischer Dynamic-Anchor FDA

**Performance**

Resistance to tension fatigue load;  
Design method I according to TR 061

**Annex C 1**

Appendix 14 / 16

**Table C2.1:** Resistance to shear fatigue load;  
Assessment method A; **(Design method I according to TR 061)**

fischer Dynamic-Anchor FDA		12x100	16x125
<b>Shear load capacity, steel failure</b>			
Characteristic steel fatigue resistance		$\Delta V_{Rk,s,0,n}$	
	[kN]		
Number of load cycles	n		
	1	30,0	55,0
	$\leq 10^3$	25,2	52,7
	$\leq 3 \cdot 10^3$	22,0	49,3
	$\leq 10^4$	17,8	42,6
	$\leq 3 \cdot 10^4$	13,9	33,4
	$\leq 10^5$	10,4	22,7
	$\leq 3 \cdot 10^5$	8,4	15,8
	$\leq 10^6$	7,3	12,8
	$> 10^6$	6,8	12,3
Partial factor	$\gamma_{Ms,V,fat}$	[-] according to TR 061, Eq. (3)	
<b>Shear load capacity, concrete pry out failure and concrete edge failure</b>			
Characteristic fatigue resistance for concrete pry out failure and concrete edge failure			
Effective length of fastener	$l_f$	100	125
Effective diameter of fastener	$d_{nom}$	14	18
Reduction factor <sup>1)</sup>		[-] $\eta_{k,c,V,fat,n} / \eta_{k,cp,V,fat,n}$	
Number of load cycles	n		
	1	1,00	
	$\leq 10^3$	0,71	
	$\leq 3 \cdot 10^3$	0,66	
	$\leq 10^4$	0,64	
	$\leq 3 \cdot 10^4$	0,63	
	$\leq 10^5$	0,62	
	$\leq 3 \cdot 10^5$	0,62	
	$\leq 10^6$	0,62	
	$> 10^6$	0,62	
Partial factor	$\gamma_{Mc/sp/p,fat}$	1,50	
Load-transfer factor	$\psi/FV$	0,85	
Exponent for combined load	$\alpha_{sn}$	0,81	1,08
Exponent for combined load	$\alpha_c$	1,50	

<sup>1)</sup>  $\Delta V_{Rk,c,0,n} = \eta_{k,c,V,fat,n} \cdot V_{Rk,c}$  with  $V_{Rk,c}$  acc. to EN 1992-4:2018

$\Delta V_{Rk,cp,0,n} = \eta_{k,cp,V,fat,n} \cdot V_{Rk,cp}$  with  $V_{Rk,cp}$  acc. to EN 1992-4:2018 (with  $k_8 = 2,0$ )

fischer Dynamic-Anchor FDA

**Performance**

Resistance to shear fatigue load;  
Design method I according to TR 061

**Annex C 2**

Appendix 15 / 16



**Table C3.1:** Resistance to tension fatigue load;  
Assessment method A; **(Design method II according to TR 061)**

fischer Dynamic-Anchor FDA			12x100	16x125
<b>Tension load capacity, steel failure</b>				
Characteristic steel fatigue resistance	$\Delta N_{Rk,s,0,\infty}$ [kN]		14,6	25,0
Partial factor	$\gamma_{Ms,N,fat}$ [-]		1,35	
<b>Tension load capacity, concrete cone failure, concrete splitting and pull out</b>				
Effective embedment depth	$h_{ef}$ [mm]		100	125
Reduction factor <sup>1)</sup>	$\eta_{k,c,N,fat,\infty}$		0,64	
Partial factor	$\gamma_{Mc,fat}$	[-]	1,50	
Load-transfer factor	$\psi_{FN}$		0,78	
Exponent for combined load	$\alpha_{sn}$		0,81	1,08

<sup>1)</sup>  $\Delta N_{Rk,c,0,\infty} = \eta_{k,c,N,fat,\infty} \cdot N_{Rk,c}$  with  $N_{Rk,c}$  acc. to EN 1992-4:2018 (with  $N^0_{Rk,c}$  with  $k_{cr,N} = 7,7$  and  $k_{ucr,N} = 11,0$ )

$\Delta N_{Rk,sp,0,\infty} = \eta_{k,sp,N,fat,\infty} \cdot N_{Rk,sp}$  with  $N_{Rk,sp}$  acc. to EN 1992-4:2018 (with  $N^0_{Rk,sp} = \min(N_{Rk,p}; N^0_{Rk,c})$ )

$\Delta N_{Rk,p,0,\infty} = \eta_{k,p,N,fat,\infty} \cdot N_{Rk,p}$  with  $N_{Rk,p}$  acc. to ETA-06/0171

$\eta_{k,c,N,fat,\infty} = \eta_{k,sp,N,fat,\infty} = \eta_{k,p,N,fat,\infty}$

Anchor FDA 12 x 100 corresponds to the anchor FHB-A 12 x 100 in ETA-06/0171 for the design under static and quasi-static load

Anchor FDA 16 x 125 corresponds to the anchor FHB-A 16 x 125 in ETA-06/0171 for the design under static and quasi-static load

**Table C3.2:** Resistance to shear fatigue load;  
Assessment method A; **(Design method II according to TR 061)**

fischer Dynamic-Anchor FDA			12x100	16x125
<b>Shear load capacity, steel failure</b>				
Characteristic steel fatigue resistance	$\Delta V_{Rk,s,0,\infty}$ [kN]		6,8	12,3
Partial factor	$\gamma_{Ms,V,fat}$ [-]		1,35	
<b>Shear load capacity, concrete pry out failure and concrete edge failure</b>				
Characteristic fatigue resistance for concrete pry out failure and concrete edge failure				
Effective length of fastener	$l_f$	[mm]	100	125
Effective diameter of fastener	$d_{nom}$		14	18
Reduction factor <sup>1)</sup>	$\eta_{k,c,V,fat,\infty}$		0,62	
Partial factor	$\gamma_{Mc,fat}$	[-]	1,50	
Load-transfer factor	$\psi_{FV}$		0,85	
Exponent for combined load	$\alpha_{sn}$		0,81	1,08

<sup>1)</sup>  $\Delta V_{Rk,c,0,\infty} = \eta_{k,c,V,fat,\infty} \cdot V_{Rk,c}$  with  $V_{Rk,c}$  acc. to EN 1992-4:2018

$\Delta V_{Rk,cp,0,\infty} = \eta_{k,cp,V,fat,\infty} \cdot V_{Rk,cp}$  with  $V_{Rk,cp}$  acc. to EN 1992-4:2018 (with  $k_8 = 2,0$ )

$\eta_{k,c,N,fat,\infty} = \eta_{k,cp,N,fat,\infty}$

fischer Dynamic-Anchor FDA	<b>Annex C 3</b> Appendix 16 / 16
<b>Performance</b> Resistance to tension fatigue load and shear fatigue load; Design method II according to TR 061	