



DICHIARAZIONE DI PRESTAZIONE



n. 0083 – IT

1. Codice di identificazione unico del prodotto-tipo: **Ancorante fischer Zykon FZA, FZA-D, FZA-I, FZA ST**

2. Usi previsti:

Prodotto	Uso/i previsto/i
Ancoranti metallici per l'utilizzo in calcestruzzo (tipo pesante)	Fissaggio installato successivamente nel calcestruzzo crepato o non crepato, vedere l'appendice, specialmente gli Annessi B 1 a B 4

3. Fabbricante: **fischerwerke GmbH & Co. KG, Klaus-Fischer-Straße 1, 72178 Waldachtal, Germania**

4. Mandatario: --

5. Sistemi di VVCP: **1**

6a. Norma armonizzata: ---

Organismi notificati: ---

6b. Documento per la valutazione europea: **ETAG 001; 2013-04**

Valutazione tecnica europea: **ETA-98/0004; 2016-09-12**

Organismo di valutazione tecnica: **DIBt**

Organismi notificati: **1343 – MPA Darmstadt**

7. Prestazioni dichiarate:

Resistenza meccanica e stabilità (BWR 1)

Caratteristiche essenziali	Prestazione
Resistenza caratteristica per azioni statiche e quasi statiche sotto azioni di trazione	Vedere appendice, specialmente Annessi C 1 a C 5
Resistenza caratteristica per azioni statiche e quasi statiche sotto azioni di taglio	Vedere appendice, specialmente Annessi C 6 a C 10
Resistenza caratteristica per categoria di prestazione sismica C1	Vedere appendice, specialmente Annessi C 11 a C 12
Spostamenti	Vedere appendice, specialmente Annessi C 13 a C 15

Sicurezza in caso di incendio (BWR 2)

Caratteristiche essenziali	Prestazione
Reazione al fuoco	Gli ancoraggi soddisfano i requisiti per la Classe A1
Resistenza al fuoco	NPD

8. Documentazione tecnica appropriata e/o documentazione tecnica specifica: ---

La prestazione del prodotto sopra identificato è conforme all'insieme delle prestazioni dichiarate. La presente dichiarazione di responsabilità viene emessa, in conformità al regolamento (UE) n. 305/2011, sotto la sola responsabilità del fabbricante sopra identificato.

Firmato a nome e per conto del fabbricante da:

Andreas Bucher, Dipl.-Ing.

Wolfgang Hengesbach, Dipl.-Ing., Dipl.-Wirtsch.-Ing.

Tumlingen, 2016-09-16

- Questa Dichiarazione di Prestazione (DoP) è stata preparata in diverse lingue. In caso di divergenza d'interpretazione avrà sempre prevalenza la versione inglese.

- L'appendice include informazioni volontarie e complementari in lingua inglese (lingua specificata neutrale) eccetto i requisiti di legge

Specific Part

1 Technical description of the product

The fischer-Zykon-Anchor FZA, FZA-D, FZA-I and FZA ST is an anchor made of galvanised or stainless or high corrosion resistant steel which is placed in an undercut hole and anchored by mechanical interlock with displacement-controlled installation.

The bolt projection anchor FZA and the through bolt anchor FZA-D consists of a conical bolt with external thread, an expansion sleeve and a hexagon nut with washer. The internal threaded anchor FZA-I consists of a conical bolt with internal thread and an expansion sleeve. The bold projecting anchor FZA ST consists of a conical bolt with hexagon projecting end, an expansion sleeve with colour marking, a hexagon nut with washer and a plastic sleeve.

The anchor is anchored by impact acting on the expansion sleeve over the cone bolts in the undercuts of the borehole.

The product description is given in Annex A.

2 Specification of the intended use in accordance with the applicable European Assessment Document

The performances given in Section 3 are only valid if the anchor is used in compliance with the specifications and conditions given in Annex B.

The verifications and assessment methods on which this European Technical Assessment is based lead to the assumption of a working life of the anchor of at least 50 years. The indications given on the working life cannot be interpreted as a guarantee given by the producer, but are to be regarded only as a means for choosing the right products in relation to the expected economically reasonable working life of the works.

3 Performance of the product and references to the methods used for its assessment

3.1 Mechanical resistance and stability (BWR 1)

Essential characteristic	Performance
Characteristic resistance for static and quasi static action to tension	See Annex C1 – C5
Characteristic resistance for static and quasi static action to shear load	See Annex C6 – C10
Characteristic resistance for seismic performance category C1	See Annex C11 – C12
Displacements	See Annex C13 - C15

3.2 Safety in case of fire (BWR 2)

Essential characteristic	Performance
Reaction to fire	Anchorage satisfy requirements for Class A1
Resistance to fire	No performance determined

3.4 Safety in use (BWR 4)

The essential characteristics regarding Safety in use are included under the Basic Works Requirement Mechanical resistance and stability.

4 Assessment and verification of constancy of performance (AVCP) system applied, with reference to its legal base

In accordance with guideline for European technical approval ETAG 001, April 2013 used as European Assessment Document (EAD) according to Article 66 Paragraph 3 of Regulation (EU) No 305/2011 the applicable European legal act is: (1996/582/EC, OJ)

The system to be applied is: 1

Bolt projecting anchor FZA:

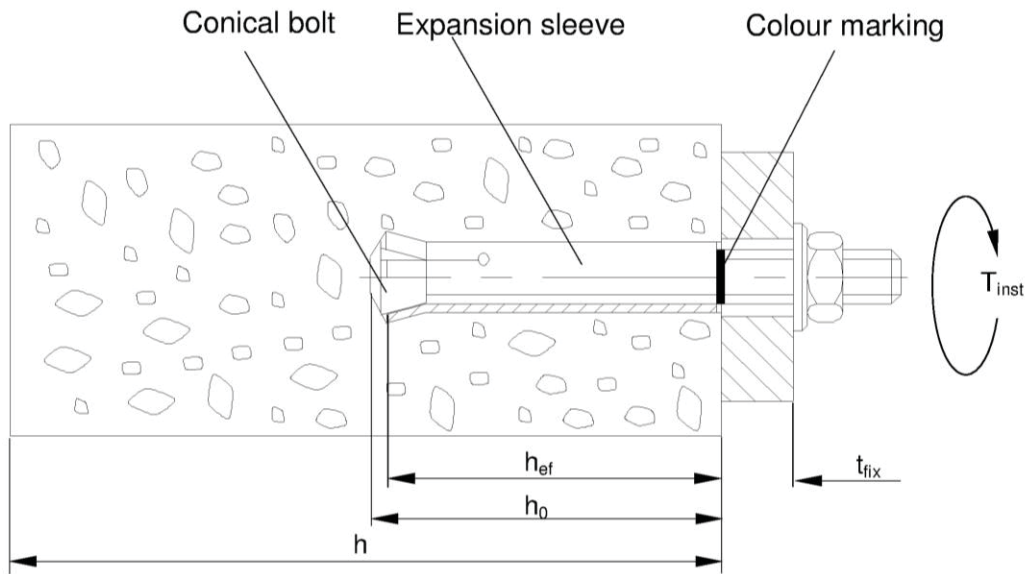

Through bolt anchor FZA-D:

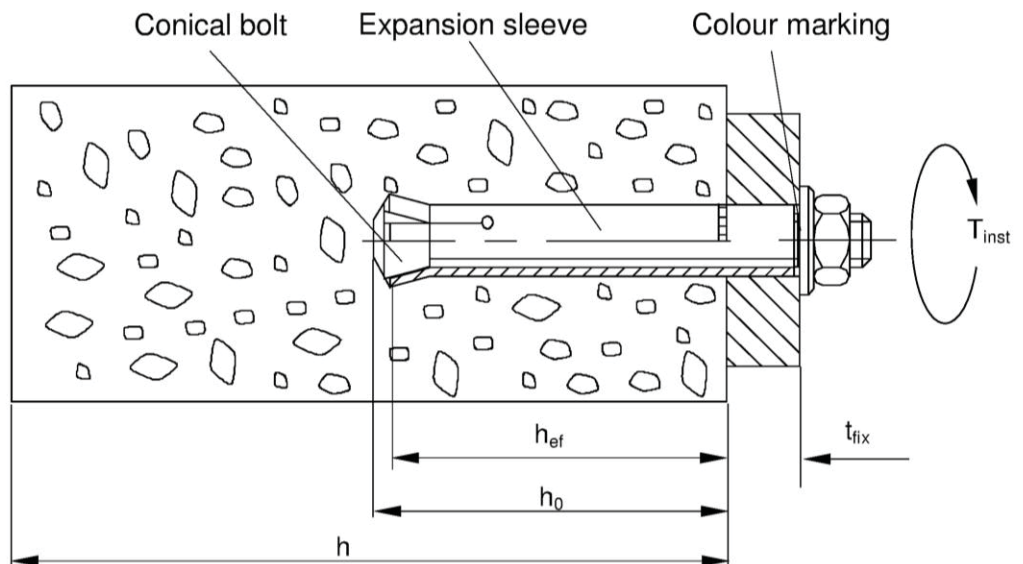

fischer-Zykon-Anchor FZA, FZA-D , FZA-I, FZA ST

Product description
Installed condition

Annex A1

Internal thread anchor FZA-I:

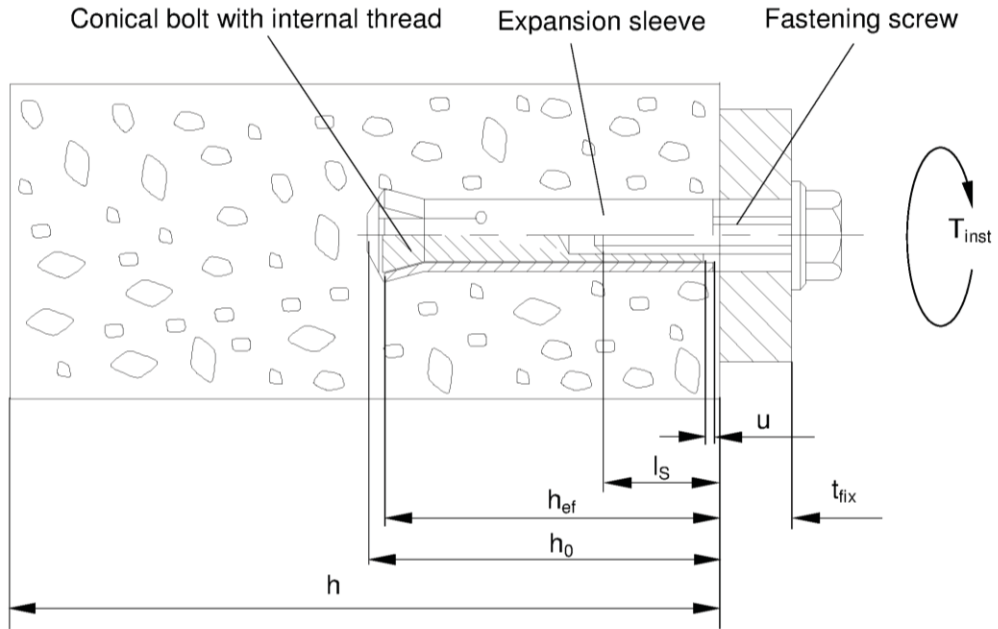

Bolt projecting anchor FZA ST:

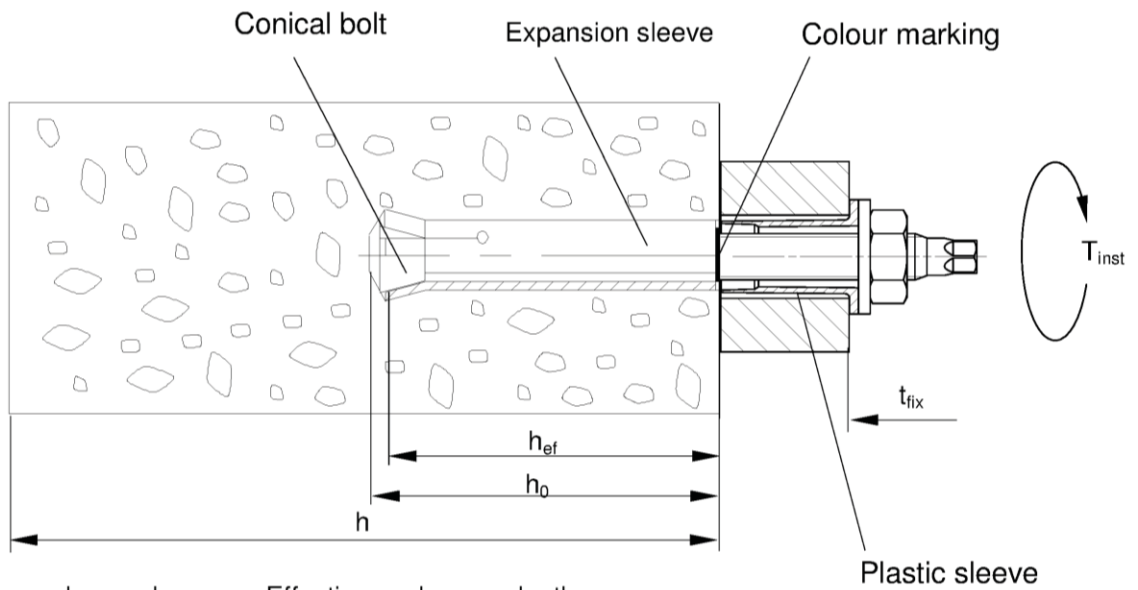

- Legend:
- h_{ef} = Effective anchorage depth
 - t_{fix} = Thickness of fixture
 - h_0 = Drill hole depth
 - h = Thickness of concrete member
 - T_{inst} = Required torque moment
 - l_s = Reach of screw
 - u = Gap between conical bolt and expansion sleeve (FZA-I)

fischer-Zykon-Anchor FZA, FZA-D , FZA-I, FZA ST

Product description
Installed condition

Annex A2

Type of anchors (allocation of parts acc. to Annex A7)

Bolt projecting anchor

FZA:

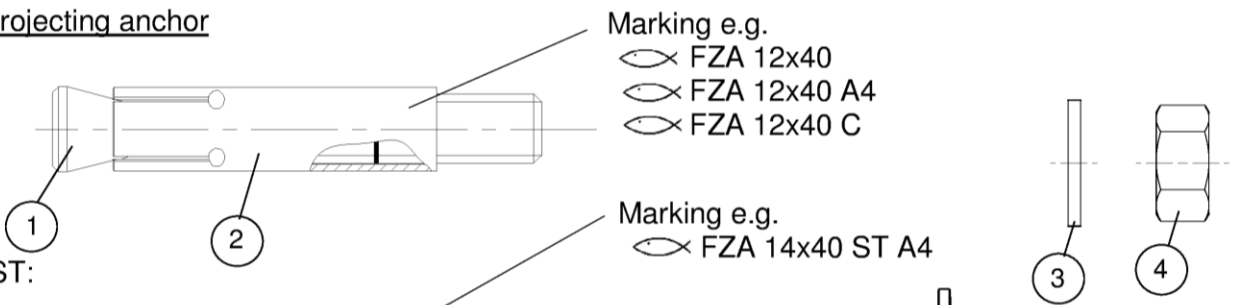

FZA ST:

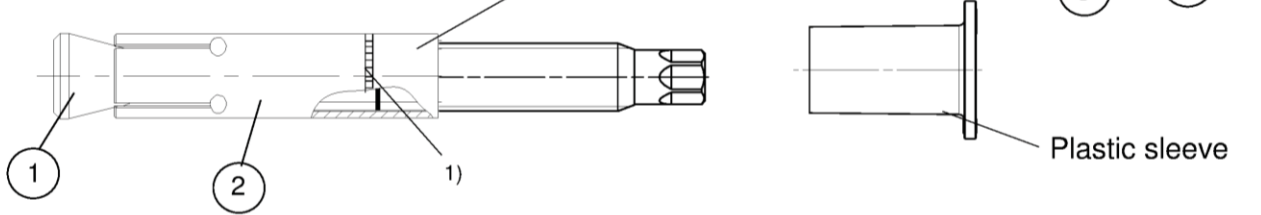

Through bolt anchor

FZA-D:

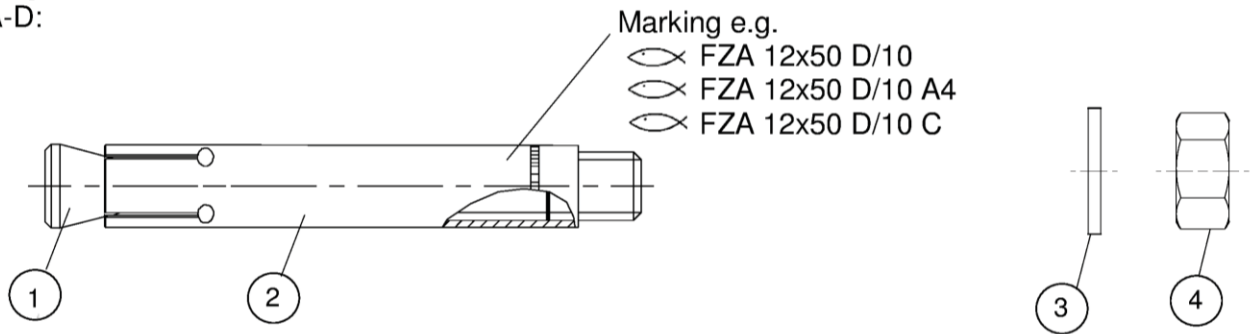

Internal thread anchor

FZA-I:

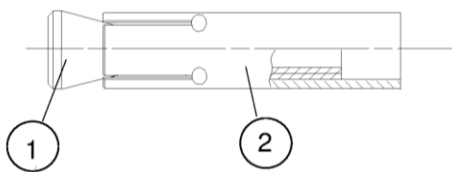

Related fastening screws respectively threaded rods must correspond to Annex A7 and with inspection certificate 3.1 acc. to EN 10204: 2004

Zykon drill
 FZUB:

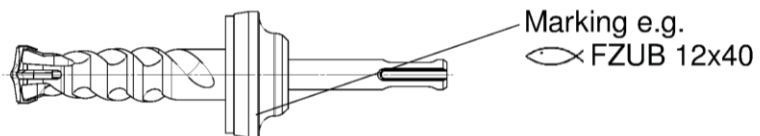

Setting tool FZE Plus
 centring pin for
 internal thread anchor

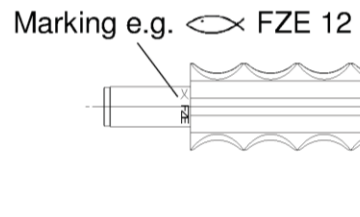

1) Expansion sleeve with knurling at FZA 12x40 ST

fischer-Zykon-Anchor FZA, FZA-D , FZA-I, FZA ST

Product description
 Anchor Types and tools

Annex A3

Types of expansion-sleeve



manufactured by punching



manufactured by turning

FZA

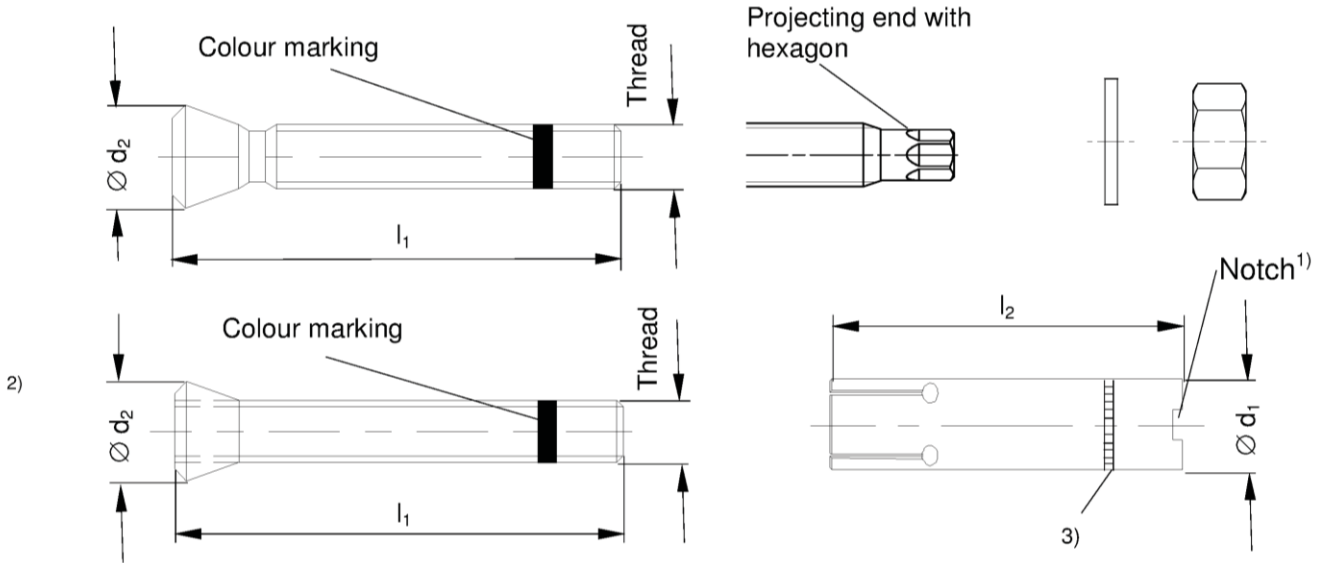

Table A1: Dimensions bolt projecting anchor FZA

Type of anchor	Thread	t _{fix} min	t _{fix} max	l ₁ min	l ₁ max	l ₂	∅ d ₁	∅ d ₂
FZA 10 x 40 M 6 / t _{fix} ¹⁾	M6	1	50	50	100	40	10	10
FZA 12 x 40 M 8 / t _{fix} ¹⁾	M8	1	100	52	154	40	12	12
FZA 14 x 40 M 10 / t _{fix} ¹⁾	M10	1	150	54	204	40	14	14
FZA 12 x 50 M 8 / t _{fix}	M8	1	100	62	164	50	12	12
FZA 14 x 60 M 10 / t _{fix}	M10	1	150	80	232	60	14	14
FZA 18 x 80 M 12 / t _{fix}	M12	1	200	99	301	80	18	18
FZA 22 x 100 M16 / t _{fix}	M16	1	250	122	374	100	22	22
FZA 22 x 125 M16 / t _{fix} ¹⁾	M16	1	250	147	399	125	22	22
FZA 12 x 40 ST A4 ¹⁾	M8	1	100	62	164	50 ³⁾	12	12
FZA 14 x 40 ST A4 ¹⁾	M10	1	150	54	204	40	14	14
FZA 14 x 60 ST A4	M10	1	150	80	232	60	14	14

¹⁾ Expansion sleeve with notch

²⁾ Design: threaded bolt with cone nut

³⁾ Expansion sleeve with knurling at FZA 12x40 ST

Dimensions in [mm]

fischer-Zykon-Anchor FZA, FZA-D , FZA-I, FZA ST

Product description
Anchor dimensions

Annex A4

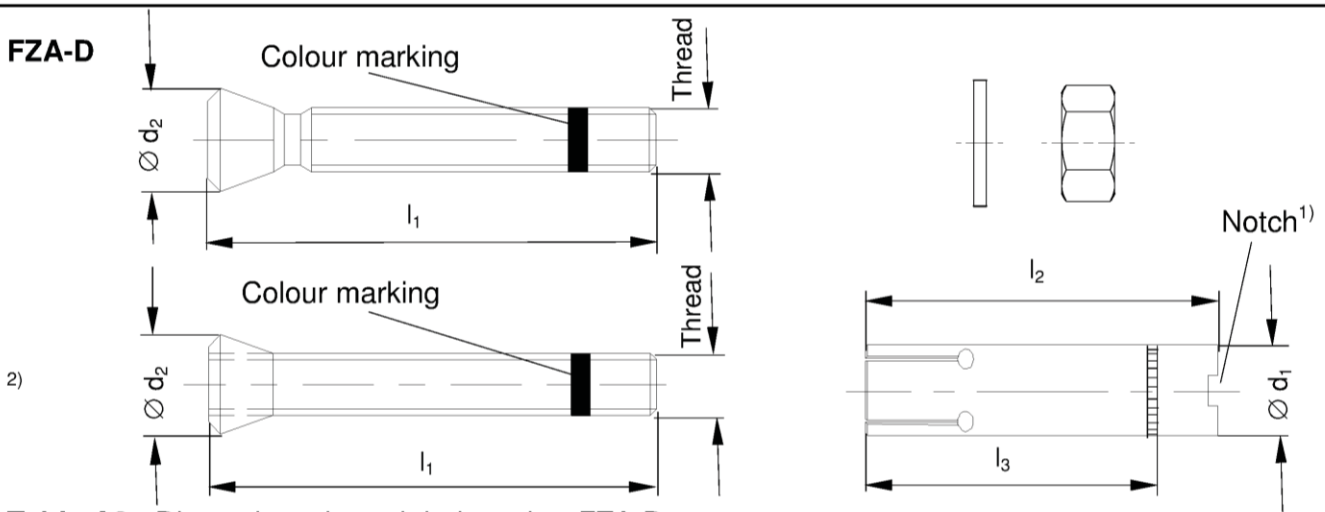

Table A2: Dimensions through bolt anchor FZA-D

Type of anchor	Thread	t _{fix} min	t _{fix} max	l ₁	l ₂	l ₃	Ø d ₁	Ø d ₂
FZA 12 x 50 M 8 D / 10 ¹⁾	M8	1	10	69	50	40	12	12
FZA 12 x 60 M 8 D / 10	M8	1	10	79	60	50	12	12
FZA 12 x 80 M 8 D / 30	M8	1	30	99	80	50	12	12
FZA 14 x 80 M 10 D / 20	M10	1	20	102	80	60	14	14
FZA 14 x 100 M 10 D / 40	M10	1	40	126	100	60	14	14
FZA 18 x 100 M 12 D / 20	M12	1	20	126	100	80	18	18
FZA 18 x 130 M 12 D / 50	M12	1	50	156	130	80	18	18
FZA 22 x 125 M 16 D / 25	M16	1	25	156	125	100	22	22

¹⁾ Expansion sleeve with notch

²⁾ Design: threaded bolt with cone nut

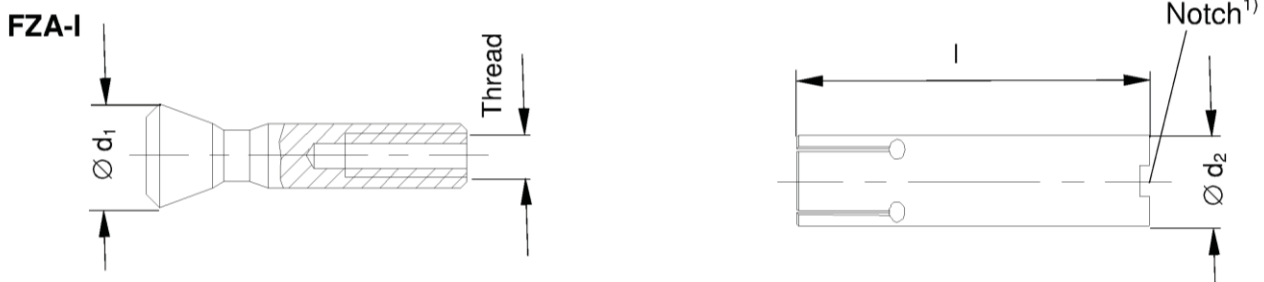

Table A3: Dimensions internal thread anchor FZA - I

Type of anchor	Thread	Ø d ₁	Ø d ₂	l
FZA 12 x 40 M 6 I ¹⁾	M6	12	12	40
FZA 12 x 50 M 6 I	M6	12	12	50
FZA 14 x 60 M 8 I	M8	14	14	60
FZA 18 x 80 M 10 I	M10	18	18	80
FZA 22 x 100 M 12 I	M12	22	22	100
FZA 22 x 125 M 12 I ¹⁾	M12	22	22	125

¹⁾ Expansion sleeve with notch

Dimensions in [mm]

fischer-Zykon-Anchor FZA, FZA-D , FZA-I, FZA ST

Product description
Anchor dimensions

Annex A5

Zykon drill FZUB

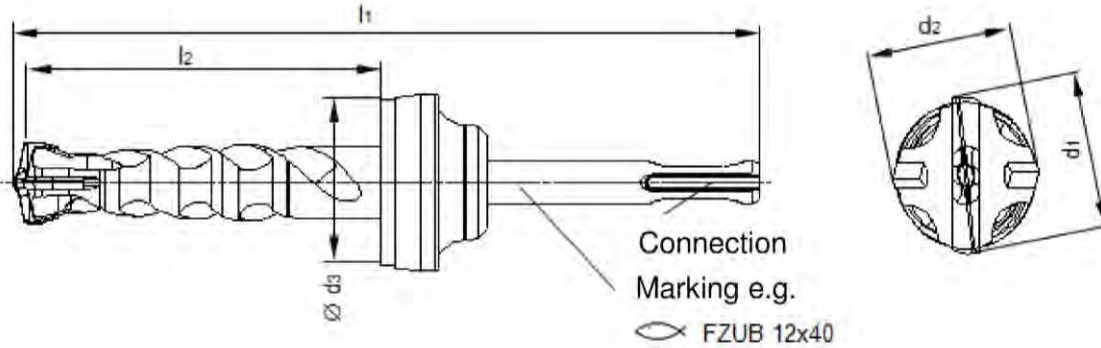
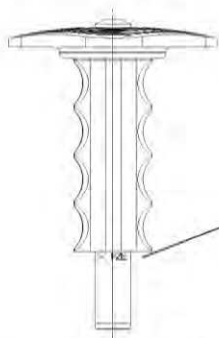

Table A4: Dimensions Zykon drill FZUB

Type of drill	Connection	l_1	$l_2 \geq$	$d_1 \leq$	d_2	$\varnothing d_3 \leq$	
FZUB 10 x 40	SDS plus	126	40	10,80	$d_2 \leq d_1$	39,5	
FZUB 12 x 40		127	40	12,82			
FZUB 12 x 50		137	50	12,82			
FZUB 12 x 60		147	60	12,82			
FZUB 12 x 80		167	80	12,82			
FZUB 14 x 40		130	40	14,82			
FZUB 14 x 60		152	60	14,82			
FZUB 14 x 80		172	80	14,82			
FZUB 14 x 100		192	100	14,82			
FZUB 18 x 80		172	80	19,40			
FZUB 18 x 100		192	100	19,40			
FZUB 18 x 130		222	130	19,40			
FZUB 22 x 100		197	100	22,95			43,5
FZUB 22 x 125		222	125	22,95			

Setting tool FZE Plus:



Centring pin for setting tool FZE Plus



Zykon drills FZUB and setting tools to use, acc. to Annex B2

Dimensions in [mm]

fischer-Zykon-Anchor FZA, FZA-D , FZA-I, FZA ST

Product description

Zykon drill FZUB and setting tool FZE Plus

Annex A6

Table A5: Materials FZA, FZA-D, FZA-I (zinc plated $\geq 5\mu\text{m}$, ISO 4042:1999)
 FZA, FZA-D (hot-dip galvanized ¹⁾, ISO 10684: 2004 $\geq 50\mu\text{m}$)

Part	Designation	Material
1	Cone bolt with external thread	Cold form steel or free cutting steel Nominal steel tensile strength: $f_{uk} \leq 1000\text{ N/mm}^2$
	Conical bolt with internal thread ²⁾	Steel, EN 10277:2008 Nominal steel tensile strength $f_{uk} \leq 1000\text{ N/mm}^2$
2	Expansion sleeve seamless or rolled	Steel
3	Washer	Cold strip, EN 10139:2016
4	Hexagon nut	Steel, property class min. 8, EN ISO 898-2:2012

Table A6: Materials FZA A4, FZA-D A4, FZA-I A4, FZA ST A4

Part	Designation	Material
1	Cone bolt with external thread	Stainless steel EN 10088:2014 Nominal steel tensile strength: $f_{uk} \leq 1000\text{ N/mm}^2$
	Conical bolt with internal thread ³⁾	Stainless steel EN 10088:2014 Nominal steel tensile strength: $f_{uk} \leq 1000\text{ N/mm}^2$
2	Expansion sleeve seamless or rolled	Stainless steel EN 10088:2014
3	Washer	Stainless steel EN 10088:2014
4	Hexagon nut	Stainless steel EN 10088:2014; ISO 3506-2:2010; property class – min. 70

Table A7: Materials FZA C, FZA-D C, FZA-I C

Part	Designation	Material
1	Cone bolt with external thread	High corrosion resistant steel EN 10088:2014 Nominal steel tensile strength: $f_{uk} \leq 1000\text{ N/mm}^2$
	Conical bolt with internal thread ⁴⁾	High corrosion resistant steel EN 10088:2014 Nominal steel tensile strength: $f_{uk} \leq 1000\text{ N/mm}^2$
2	Expansion sleeve seamless or rolled	High corrosion resistant steel EN 10088:2014
3	Washer	High corrosion resistant steel EN 10088:2014
4	Hexagon nut	High corrosion resistant steel EN 10088:2014; ISO 3506-2:2010; property class – min. 70

¹⁾ Alternative method sherardized, EN 13811:2003 $\geq 50\mu\text{m}$

²⁾ Related screws or threaded rods: property class 8.8 according to EN ISO 898-1:2013; ductility $A_5 > 8\%$; zinc plated.

³⁾ Related screws or threaded rods: property class ≥ 70 according to EN ISO 3506-1:2010; ductility $A_5 > 8\%$; stainless steel 1.4401, 1.4404, 1.4578, 1.4571, 1.4439, 1.4362 according EN 10088:2014.

⁴⁾ Related screws or threaded rods: property class ≥ 70 according to EN ISO 3506-1:2010; ductility $A_5 > 8\%$; high corrosion resistant steel 1.4529, 1.4565 according EN 10088:2014.

fischer-Zykon-Anchor FZA, FZA-D , FZA-I, FZA ST

Product description
 Materials

Annex A7

Specifications of intended use

Anchorage subject to:

- Static and quasi-static loads
- Seismic Performance Category C1 sizes FZA14x40, FZA14x60, FZA18x80, FZA22x100, FZA 22x125 and FZA14x80D/20, FZA14x100D/40, FZA18x100D/20, FZA18x130D/50, FZA22x125D/25

Base materials:

- Reinforced and unreinforced normal weight concrete according to EN 206-1:2000
- Strength classes C20/25 to C50/60 according to EN 206-1:2000
- Cracked and non-cracked concrete

Use conditions (Environmental conditions):

- Structures subject to dry internal conditions
(Zinc plated steel, hot-dip galvanized steel, stainless steel, high corrosion- resistant steel)
- Structures subject to external atmospheric exposure (including industrial and marine environment) and to permanently damp internal condition, if no particular aggressive conditions exist
(stainless steel, high corrosion-resistant steel)
- Structures subject to external atmospheric exposure and permanently damp internal condition, if other particular aggressive conditions exist
(high corrosion-resistant steel)

Note: Particular aggressive conditions are e.g. permanent, alternating immersion in seawater or the splash zone of seawater, chloride atmosphere of indoor swimming pools or atmosphere with extreme chemical pollution (e.g. in desulphurization plants or road tunnels where de-icing materials are used)

Design:

- Anchorages are designed under the responsibility of an engineer experienced in anchorages and concrete work
- Verifiable calculation notes and drawings be prepared taking account of the loads to be anchored. The position of the anchor is indicated on the design drawings (e.g. position of the anchor relative to reinforcement or to supports, etc.)
- Anchorages under static or quasi-static actions be designed in accordance with (please choose the relevant design method):
 - ETAG 001, Annex C, design method A, Edition August 2010 or
 - CEN/TS 1992-4:2009, design method A
- Anchorages under seismic actions (cracked concrete) be designed in accordance with:
 - EOTA Technical Report TR 045, Edition February 2013
 - Anchorages shall be positioned outside of critical regions (e.g. plastic hinges) of the concrete structure.
 - Fastenings in stand-off installation or with a grout layer under seismic action are not allowed

Installation:

- Anchor installation carried out by appropriately qualified personnel and under the supervision of the person responsible for technical matters of the site
- Anchor must be installed to comply with the correct anchorage depth. This is assured when the front face of the sleeve, for the internal thread, is approximately 1mm below the concrete surface or, in the case of the through fixing versions, approximately 1mm below the front surface of fixture. When using the FZA 12x40 ST the knurling on the sleeve is flush or below the concrete surface

fischer Zykon Anchor FZA, FZA-I , FZA-D, FZA ST	Annex B1
Intended Use Specifications	

Table B1: Installation parameters for FZA, FZA-D, FZA-I

Type of anchor	Drill hole depth h_0 [mm]	Drill FZUB	Setting tool FZE Plus	d_f ²⁾ \leq [mm]	Torque moment ¹⁾ T_{inst} [Nm]	Gap u [mm]	Reach of screw l_s [mm]	
							max	min
FZA 10 x 40 M 6 / t_{fix}	≥ 43	10 x 40	10	7	8,5		-	-
FZA 12 x 40 M 8 / t_{fix}	≥ 43	12 x 40	12	9	20	-	-	-
FZA 14 x 40 M 10 / t_{fix}	≥ 43	14 x 40	14	12	40	-	-	-
FZA 12 x 50 M 8 / t_{fix}	≥ 54	12 x 50	12	9	20	-	-	-
FZA 14 x 60 M 10 / t_{fix}	≥ 63	14 x 60	14	12	40	-	-	-
FZA 18 x 80 M 12 / t_{fix}	≥ 83	18 x 80	18	14	60	-	-	-
FZA 22 x 100 M16 / t_{fix}	≥ 103	22 x 100	22	18	100	-	-	-
FZA 22 x 125 M16 / t_{fix}	≥ 127	22 x 125	22	18	100	-	-	-
FZA 12 x 40 ST A4	≥ 43	12 x 40	12	17 ³⁾	20	-	-	-
FZA 14 x 40 ST A4	≥ 43	14 x 40	14	17 ³⁾	20	-	-	-
FZA 14 x 60 ST A4	≥ 63	14 x 60	14	17 ³⁾	20	-	-	-
FZA 12 x 50 M 8 D / 10	≥ 43	12 x 50	12	14	20	-	-	-
FZA 12 x 60 M 8 D / 10	≥ 53	12 x 60	12	14	20	-	-	-
FZA 12 x 80 M 8 D / 30	≥ 53	12 x 80	12	14	20	-	-	-
FZA 14 x 80 M 10 D / 20	≥ 63	14 x 80	14	16	40	-	-	-
FZA 14 x 100 M 10 D / 40	≥ 63	14 x 100	14	16	40	-	-	-
FZA 18 x 100 M 12 D / 20	≥ 83	18 x 100	18	20	60	-	-	-
FZA 18 x 130 M 12 D / 50	≥ 83	18 x 130	18	20	60	-	-	-
FZA 22 x 125 M 16 D / 25	≥ 105	22 x 125	22	24	100	-	-	-
FZA 12 x 40 M 6 I	≥ 43	12 x 40	12 +FZE 12 I	7	8,5	0 – 4,0	15	10
FZA 12 x 50 M 6 I	≥ 53	12 x 50	12 +FZE 12 I	7	8,5	0 – 4,0	15	10
FZA 14 x 60 M 8 I	≥ 63	14 x 60	14 + FZE 14 I	9	15	0 – 4,0	18	12
FZA 18 x 80 M 10 I	≥ 83	18 x 80	18 + FZE 18 I	12	30	0 – 4,5	24	16
FZA 22 x 100 M 12 I	≥ 103	22 x 100	22 + FZE 22 I	14	60	0 – 4,5	26	16
FZA 22 x 125 M 12 I	≥ 127	22 x 125	22 + FZE 22 I	14	60	0 – 4,5	26	16

¹⁾ If the FZA with an internal thread (FZA-I) is used with a threaded rod or a screw according to Annex A7 the torque moment must be applied as given in the table

²⁾ Diameter of the clearance hole in the fixture

³⁾ The displacements due to tension and shear loads given in table C13 and C16 do not apply for FZA ST

fischer Zykon Anchor FZA, FZA-I, FZA-D, FZA ST

Intended Use
Installation parameters

Annex B2

Table B2: Minimum thickness of concrete members, minimum spacings and minimum edge distances of **bolt projecting anchor FZA**

Type of anchor		FZA 10x40 M6 / t _{fix}	FZA 12x40 12x40 ST M8 / t _{fix}	FZA 14x40 14x40 ST M10 / t _{fix}	FZA 12x50 M8 / t _{fix}
Minimum thickness of concrete member, minimum spacings and minimum edge distances of anchors FZA, FZA A4, FZA C					
Minimum spacing	s _{min} [mm]	40	40	70	50
Minimum edge distance	c _{min} [mm]	35	40	70	45
Minimum thickness of concrete member	h _{min} [mm]	100	100	100	110
Type of anchor		FZA 14x60 14x60 ST M10 / t _{fix}	FZA 18x80 M12 / t _{fix}	FZA 22x100 M16 / t _{fix}	FZA 22x125 M16 / t _{fix}
Minimum thickness of concrete member, minimum spacings and minimum edge distances of anchors FZA, FZA A4, FZA C					
Minimum spacing	s _{min} [mm]	60	80	100	125
Minimum edge distance	c _{min} [mm]	55	70	100	125
Minimum thickness of concrete member	h _{min} [mm]	130	160	200	250

Table B3: Minimum thickness of concrete members, minimum spacings and minimum edge distances of **through bolt anchor FZA D**

Type of anchor		FZA 12x50 M8D/10	FZA 12x60 M8D/10	FZA 12x80 M8D/30	FZA 14x80 M10D/20
Minimum thickness of concrete member, minimum spacings and minimum edge distances of anchors FZA D, FZA D A4, FZA D C					
Minimum spacing	s _{min} [mm]	40	50	50	60
Minimum edge distance	c _{min} [mm]	35	45	45	55
Minimum thickness of concrete member	h _{min} [mm]	100	110	110	130
Type of anchor		FZA 14x100 M10D/40	FZA 18x100 M12D/20	FZA 18x130 M12D/50	FZA 22x125 M16D/25
Minimum thickness of concrete member, minimum spacings and minimum edge distances of anchors FZA D, FZA D A4, FZA D C					
Minimum spacing	s _{min} [mm]	60	80	80	100
Minimum edge distance	c _{min} [mm]	55	70	70	100
Minimum thickness of concrete member	h _{min} [mm]	130	160	160	200

Table B4: Minimum thickness of concrete members, minimum spacings and minimum edge distances of **internal thread anchor FZA-I**

Type of anchor		FZA 12x40 M6 I	FZA 12x50 M6 I	FZA 14x60 M8 I	FZA 18x80 M10 I	FZA 22x100 M12 I	FZA 22x125 M12 I
Minimum thickness of concrete member, minimum spacings and minimum edge distances of anchors FZA I, FZA I A4, FZA I C							
Minimum spacing	s _{min} [mm]	40	50	60	80	100	125
Minimum edge distance	c _{min} [mm]	35	45	55	70	100	125
Minimum thickness of concrete member	h _{min} [mm]	100	110	130	160	200	250

fischer Zykon Anchor FZA, FZA-I , FZA-D, FZA ST

Intended Use
Installation parameters - Minimum thickness of concrete member, minimum spacings and minimum edge distances

Annex B3

Installation instructions for FZA, FZA-D, FZA-I, FZA ST

Pre-positioned installation

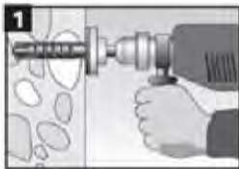

1 Create a drill hole at right angles to the surface of the anchor base with a hammer drill, using the corresponding Zykon universal drill bit FZUB. The required drill depth is reached once the FZUB depth stop meets the concrete.

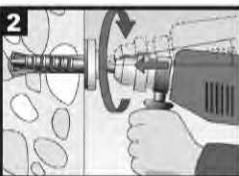

2 Once the FZUB depth stop meets the concrete, create the drill hole undercut by making circular swiveling movements with the hammer drill while the hammer mechanism is engaged. Press the hammer drill firmly against the anchor base: 1-2 swiveling movements are sufficient for \varnothing 14 mm, with 3-5 movements for \varnothing 18 mm and \varnothing 22 mm

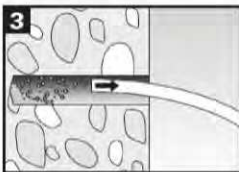

3 Clean drill hole.

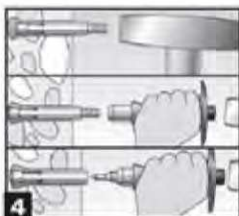

4 Insert the anchor into the drill hole and then drive the expansion sleeve in with hammer-set device FZE Plus, using a manual hammer.

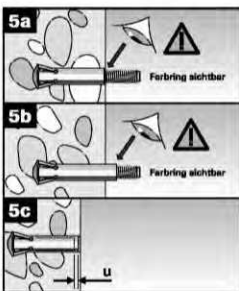

5a The anchor is correctly expanded if the colour marking on the thread of the tapered bolt is visible or the gap u is fulfilled.

5b When using the FZA 12x40 ST the knurling on the sleeve is flush or below the concrete surface.

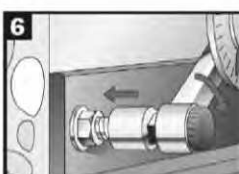

6 Mount installation object (e.g. anchor plate), washer and nut, screw (for FZA-I) or threaded rod with washer and nut (for FZA-I) and apply installation torque with torque spanner.

Push-through installation

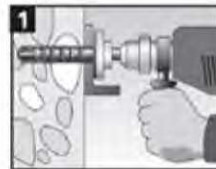

1 Create a drill hole through the installation object at right angles to the surface of the anchor base with a hammer drill, using the corresponding Zykon universal drill bit FZUB. The required drill depth is reached once the FZUB depth stop meets the fixture.

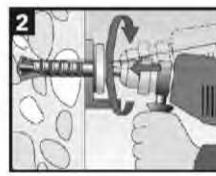

2 Once the FZUB depth stop meets the fixture, create the drill hole undercut by making circular swiveling movements with the hammer drill while the hammer mechanism is engaged. Press the hammer drill firmly against the anchor base: 1-2 swiveling movements are sufficient for \varnothing 14 mm, with 3-5 movements for \varnothing 18 mm and \varnothing 22 mm

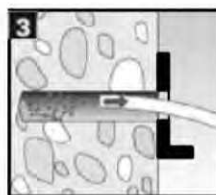

3 Clean drill hole.

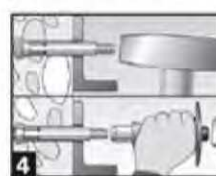

4 Insert the anchor into the drill hole and then drive the expansion sleeve in with hammer-set device FZE Plus, using a manual hammer. The setting depth marking (knurl) is approx. 1mm behind the surface of the concrete.

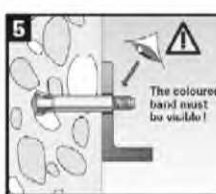

5 The anchor is correctly expanded if the colour marking on the thread of the tapered bolt is visible.

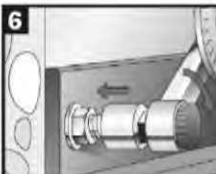

6 Mount installation object (e.g. anchor plate), washer and nut and apply installation torque with torque spanner.

fischer Zykon Anchor FZA, FZA-I, FZA-D, FZA ST

Intended Use

Installation instructions for FZA, FZA-D and FZA I

Annex B4

Table C1: Characteristic values of **tension** resistance under static and quasi-static action for **bolt projecting anchor FZA** (Design method A, according to **ETAG 001, Annex C** or **CEN/TS 1992-4**)

Type of anchor / size	FZA (bolt projecting anchor)				
	10x40 M6 / t _{fix}	12x40 12x40 ST M8 / t _{fix}	14x40 14x40 ST M10 / t _{fix}	12x50 M8 / t _{fix}	
Steel failure for FZA galvanized					
Characteristic resistance	N _{Rk,s} [kN]	16,1	29,3	46,4	29,3
Partial safety factor	γ _{Ms} ¹⁾	1,5			
Steel failure for FZA hot-dip galvanized					
Characteristic resistance	N _{Rk,s} [kN]	13,1	25,0	40,7	25,0
Partial safety factor	γ _{Ms} ¹⁾	1,5			
Steel failure for FZA A4					
Characteristic resistance	N _{Rk,s} [kN]	14,1	25,6	40,6	25,6
Partial safety factor	γ _{Ms} ¹⁾	1,87			
Steel failure for FZA C					
Characteristic resistance	N _{Rk,s} [kN]	14,1	25,6	40,6	25,6
Partial safety factor	γ _{Ms} ¹⁾	1,5			
Pullout failure for FZA, FZA A4, FZA C					
Characteristic resistance in cracked concrete C20/25	N _{Rk,p} [kN]	6	6	6	9
Characteristic resistance in non - cracked concrete C20/25	N _{Rk,p} [kN]	9	9	9	12
Increasing factors for N _{Rk,p} for cracked and non – cracked concrete	ψ _c	C25/30	1,10		
		C30/37	1,22		
		C35/45	1,34		
		C40/50	1,41		
		C45/55	1,48		
		C50/60	1,55		
Installation safety factor	γ ₂ = γ _{inst}	1,2			1,0
Concrete cone failure and splitting failure for FZA, FZA A4, FZA C					
Effective anchorage depth	h _{ef} [mm]	40	40	40	50
Factor for non-cracked concrete	k _{ucr} [-]	10,1			
Factor for cracked concrete	k _{cr} [-]	7,2			
Min. thickness of concrete member	h _{min} [mm]	100	100	100	110
Characteristic spacing	s _{cr,N} = s _{cr,sp} [mm]	3 h _{ef}			
Characteristic edge distance	c _{cr,N} = c _{cr,sp} [mm]	1,5 h _{ef}			

¹⁾ In absence of other national regulations

fischer-Zykon-Anchor FZA, FZA-D , FZA-I, FZA ST

Performances

Characteristic values of resistance under tension loads for bolt projecting anchor FZA

Annex C1

Table C2: Characteristic values of **tension** resistance under static and quasi-static action for **bolt projecting anchor FZA** (Design method A, according to **ETAG 001, Annex C** or **CEN/TS 1992-4**)

Type of anchor / size		FZA (bolt projecting anchor)			
		14x60 14x60 ST M10 / t _{fix}	18x80 M12 / t _{fix}	22x100 M16 / t _{fix}	22x125 M16 / t _{fix}
Steel failure for FZA galvanized					
Characteristic resistance	N _{Rk,s} [kN]	46,4	67,4	126	126
Partial safety factor	γ _{Ms} ¹⁾	1,5			
Steel failure for FZA hot-dip galvanized					
Characteristic resistance	N _{Rk,s} [kN]	40,7	60,1	115	115
Partial safety factor	γ _{Ms} ¹⁾	1,5			
Steel failure for FZA A4					
Characteristic resistance	N _{Rk,s} [kN]	40,6	59,0	110	110
Partial safety factor	γ _{Ms} ¹⁾	1,87			
Steel failure for FZA C					
Characteristic resistance	N _{Rk,s} [kN]	40,6	59,0	110	110
Partial safety factor	γ _{Ms} ¹⁾	1,5			
Pullout failure for FZA, FZA A4, FZA C					
Characteristic resistance in cracked concrete C20/25	N _{Rk,p} [kN]	12	20	40	40
Characteristic resistance in non - cracked concrete C20/25	N _{Rk,p} [kN]	20	30	40	40
Increasing factors for N _{Rk,p} for cracked and non – cracked concrete	ψ _c	C25/30	1,10		
		C30/37	1,22		
		C35/45	1,34		
		C40/50	1,41		
		C45/55	1,48		
		C50/60	1,55		
Installation safety factor	γ ₂ = γ _{inst}	1,0			
Concrete cone failure and splitting failure for FZA, FZA A4, FZA C					
Effective anchorage depth	h _{ef} [mm]	60	80	100	125
Factor for non-cracked concrete	k _{ucr} [-]	10,1			
Factor for cracked concrete	k _{cr} [-]	7,2			
Min. thickness of concrete member	h _{min} [mm]	130	160	200	250
Characteristic spacing	s _{cr,N} = s _{cr,sp} [mm]	3 h _{ef}			
Characteristic edge distance	c _{cr,N} = c _{cr,sp} [mm]	1,5 h _{ef}			

¹⁾ In absence of other national regulations

fischer-Zykon-Anchor FZA, FZA-D , FZA-I, FZA ST

Performances

Characteristic values of resistance under tension loads for bolt projecting anchor FZA

Annex C2

Table C3: Characteristic values of **tension** resistance under static and quasi-static action for **through bolt anchor FZA D** (Design method A, according to **ETAG 001, Annex C** or **CEN/TS 1992-4**)

Type of anchor / size		FZA D (through bolt anchor)			
		12x50 M8D/10	12x60 M8D/10	12x80 M8D/30	14x80 M10D/20
Steel failure for FZA D galvanized					
Characteristic resistance	$N_{Rk,s}$ [kN]	29,3	29,3	29,3	46,4
Partial safety factor	$\gamma_{Ms}^{1)}$	1,5			
Steel failure for FZA D hot-dip galvanized					
Characteristic resistance	$N_{Rk,s}$ [kN]	25,0	25,0	25,0	40,7
Partial safety factor	$\gamma_{Ms}^{1)}$	1,5			
Steel failure for FZA D A4					
Characteristic resistance	$N_{Rk,s}$ [kN]	25,6	25,6	25,6	40,6
Partial safety factor	$\gamma_{Ms}^{1)}$	1,87			
Steel failure for FZA D C					
Characteristic resistance	$N_{Rk,s}$ [kN]	25,6	25,6	25,6	40,6
Partial safety factor	$\gamma_{Ms}^{1)}$	1,5			
Pullout failure for FZA D, FZA D A4, FZA D C					
Characteristic resistance in cracked concrete C20/25	$N_{Rk,p}$ [kN]	6	9	9	12
Characteristic resistance in non - cracked concrete C20/25	$N_{Rk,p}$ [kN]	9	12	12	20
Increasing factors for $N_{Rk,p}$ for cracked and non – cracked concrete	ψ_c	C25/30	1,10		
		C30/37	1,22		
		C35/45	1,34		
		C40/50	1,41		
		C45/55	1,48		
		C50/60	1,55		
Installation safety factor	$\gamma_2 = \gamma_{inst}$	1,2	1,0		
Concrete cone failure and splitting failure for FZA D, FZA D A4, FZA D C					
Effective anchorage depth	h_{ef} [mm]	40	50	50	60
Factor for non-cracked concrete	k_{ucr} [-]	10,1			
Factor for cracked concrete	k_{cr} [-]	7,2			
Min. thickness of concrete member	h_{min} [mm]	100	110	110	130
Characteristic spacing	$s_{cr,N} = s_{cr,sp}$ [mm]	3 h_{ef}			
Characteristic edge distance	$c_{cr,N} = c_{cr,sp}$ [mm]	1,5 h_{ef}			

¹⁾ In absence of other national regulations

fischer-Zykon-Anchor FZA, FZA-D , FZA-I, FZA ST

Performances

Characteristic values of resistance under tension loads for through bolt anchor FZA D

Annex C3

Table C4: Characteristic values of **tension** resistance under static and quasi-static action for **through bolt anchor FZA D** (Design method A, according to **ETAG 001, Annex C** or **CEN/TS 1992-4**)

Type of anchor / size		FZA D (through bolt anchor)			
		14x100 M10D/40	18x100 M12D/20	18x130 M12D/50	22x125 M16D/25
Steel failure for FZA D galvanized					
Characteristic resistance	$N_{Rk,s}$ [kN]	46,6	67,4	67,4	126,0
Partial safety factor	$\gamma_{Ms}^{1)}$	1,5			
Steel failure for FZA D hot-dip galvanized					
Characteristic resistance	$N_{Rk,s}$ [kN]	40,7	60,1	60,1	115
Partial safety factor	$\gamma_{Ms}^{1)}$	1,5			
Steel failure for FZA D A4					
Characteristic resistance	$N_{Rk,s}$ [kN]	40,6	59,0	59,0	110,0
Partial safety factor	$\gamma_{Ms}^{1)}$	1,87			
Steel failure for FZA D C					
Characteristic resistance	$N_{Rk,s}$ [kN]	40,6	59,0	59,0	110,0
Partial safety factor	$\gamma_{Ms}^{1)}$	1,5			
Pullout failure for FZA D, FZA D A4, FZA D C					
Characteristic resistance in cracked concrete C20/25	$N_{Rk,p}$ [kN]	12	20	20	40
Characteristic resistance in non - cracked concrete C20/25	$N_{Rk,p}$ [kN]	20	30	30	40
Increasing factors for $N_{Rk,p}$ for cracked and non – cracked concrete	ψ_c	C25/30	1,10		
		C30/37	1,22		
		C35/45	1,34		
		C40/50	1,41		
		C45/55	1,48		
		C50/60	1,55		
Installation safety factor	$\gamma_2 = \gamma_{inst}$	1,0			
Concrete cone failure and splitting failure for FZA D, FZA D A4, FZA D C					
Effective anchorage depth	h_{ef} [mm]	60	80	80	100
Factor for non-cracked concrete	k_{ucr} [-]	10,1			
Factor for cracked concrete	k_{cr} [-]	7,2			
Min. thickness of concrete member	h_{min} [mm]	130	160	160	200
Characteristic spacing	$s_{cr,N} = s_{cr,sp}$ [mm]	3 h_{ef}			
Characteristic edge distance	$c_{cr,N} = c_{cr,sp}$ [mm]	1,5 h_{ef}			

¹⁾ In absence of other national regulations

fischer-Zykon-Anchor FZA, FZA-D , FZA-I, FZA ST

Performances

Characteristic values of resistance under tension loads for through bolt anchor FZA D

Annex C4

Table C5: Characteristic values of **tension** resistance under static and quasi-static action for **internal thread anchor FZA I** (Design method A, according to **ETAG 001, Annex C** or **CEN/TS 1992-4**)

Type of anchor / size		FZA I (internal thread anchor)					
		12x40 M6 I	12x50 M6 I	14x60 M8 I	18x80 M10 I	22x100 M12 I	22x125 M12 I
Steel failure for FZA I							
Characteristic resistance	$N_{Rk,s}$ [kN]	16,1	16,1	22,9	26,9	63,0	63,0
Partial safety factor	γ_{Ms} ¹⁾	1,75			2,0		
Steel failure for FZA I A4							
Characteristic resistance	$N_{Rk,s}$ [kN]	13,5	13,5	17,9	22,7	53,1	53,1
Partial safety factor	γ_{Ms} ¹⁾	1,8					
Steel failure for FZA I C							
Characteristic resistance	$N_{Rk,s}$ [kN]	13,5	13,5	17,9	22,7	53,1	53,1
Partial safety factor	γ_{Ms} ¹⁾	1,8					
Pullout failure for FZA I, FZA I A4, FZA I C							
Characteristic resistance in cracked concrete C20/25	$N_{Rk,p}$ [kN]	6	9	12	20	40	40
Characteristic resistance in non - cracked concrete C20/25	$N_{Rk,p}$ [kN]	9	12	20	30	40	40
Increasing factors for $N_{Rk,p}$ for cracked and non – cracked concrete	ψ_c	C25/30	1,10				
		C30/37	1,22				
		C35/45	1,34				
		C40/50	1,41				
		C45/55	1,48				
		C50/60	1,55				
Installation safety factor	$\gamma_2 = \gamma_{inst}$	1,2	1,0				
Concrete cone failure and splitting failure for FZA I, FZA I A4, FZA I C							
Effective anchorage depth	h_{ef} [mm]	40	50	60	80	100	125
Factor for non-cracked concrete	k_{ucr} [-]	10,1					
Factor for cracked concrete	k_{cr} [-]	7,2					
Min. thickness of concrete member	h_{min} [mm]	100	110	130	160	200	250
Characteristic spacing	$s_{cr,N} = s_{cr,sp}$ [mm]	3 h_{ef}					
Characteristic edge distance	$c_{cr,N} = c_{cr,sp}$ [mm]	1,5 h_{ef}					

¹⁾ In absence of other national regulations

fischer-Zykon-Anchor FZA, FZA-D , FZA-I, FZA ST

Performances

Characteristic values of resistance under tension loads for internal thread anchor FZA I

Annex C5

Table C6: Characteristic values of **shear** resistance under static and quasi-static action for **bolt projecting anchor FZA** (Design method A, according to **ETAG 001, Annex C** or **CEN/TS 1992-4:2009**)

Type of anchor / size	FZA (bolt projecting anchor)				
	10x40 M6 / t _{fix}	12x40 12x40 ST M8 / t _{fix}	14x40 14x40 ST M10 / t _{fix}	12x50 M8 / t _{fix}	
Steel failure without lever arm FZA galvanized / hot-dip galvanized					
Characteristic resistance	V _{Rk,s} [kN]	8,0	14,7	23,2	14,7
Partial safety factor	γ _{Ms} ¹⁾	1,25			
Factor for ductility	k ₂ [-]	1,0			
Steel failure with lever arm FZA galvanized / hot-dip galvanized					
Characteristic bending resistance	M ⁰ _{Rk,s} [Nm]	12,2	30,0	59,8	30,0
Partial safety factor	γ _{Ms} ¹⁾	1,25			
Factor for ductility	k ₂ [-]	1,0			
Steel failure without lever arm FZA A4					
Characteristic resistance	V _{Rk,s} [kN]	7,0	12,8	20,3	12,8
Partial safety factor	γ _{Ms} ¹⁾	1,56			
Factor for ductility	k ₂ [-]	1,0			
Steel failure with lever arm FZA A4					
Characteristic bending resistance	M ⁰ _{Rk,s} [Nm]	10,7	26,2	52,3	26,2
Partial safety factor	γ _{Ms} ¹⁾	1,56			
Factor for ductility	k ₂ [-]	1,0			
Steel failure without lever arm FZA C					
Characteristic resistance	V _{Rk,s} [kN]	7,0	12,8	20,3	12,8
Partial safety factor	γ _{Ms} ¹⁾	1,25			
Factor for ductility	k ₂ [-]	1,0			
Steel failure with lever arm FZA C					
Characteristic bending resistance	M ⁰ _{Rk,s} [Nm]	10,7	26,2	52,3	26,2
Partial safety factor	γ _{Ms} ¹⁾	1,25			
Factor for ductility	k ₂ [-]	1,0			
Concrete pryout failure FZA, FZA A4, FZA C					
Factor k according to ETAG 001, Annex C or k ₃ according to CEN/TS 1992-4	k = k ₃ [-]	1,3			
Concrete edge failure					
Effective length of anchor in shear loading	l _f [mm]	40	40	40	50
Effective diameter of anchor	d _{nom} [mm]	10	12	14	12
Installation safety factor	γ ₂ = γ _{inst}	1,0			

¹⁾ In absence of other national regulations

fischer-Zykon-Anchor FZA, FZA-D , FZA-I, FZA ST

Performances

Characteristic values of resistance under shear loads for bolt projecting anchor FZA

Annex C6

Table C7: Characteristic values of **shear** resistance under static and quasi-static action for **bolt projecting anchor FZA** (Design method A, according to **ETAG 001, Annex C** or **CEN/TS 1992-4:2009**)

Type of anchor / size	FZA (bolt projecting anchor)				
	14x60 14x60 ST M10 / t _{fix}	18x80 M12 / t _{fix}	22x100 M16 / t _{fix}	22x125 M16 / t _{fix}	
Steel failure without lever arm FZA galvanized / hot-dip galvanized					
Characteristic resistance	V _{Rk,s} [kN]	23,2	33,8	62,8	62,8
Partial safety factor	γ _{Ms} ¹⁾	1,25			
Factor for ductility	k ₂ [-]	1,0			
Steel failure with lever arm FZA galvanized / hot-dip galvanized					
Characteristic bending resistance	M ⁰ _{Rk,s} [Nm]	59,8	105	266	266
Partial safety factor	γ _{Ms} ¹⁾	1,25			
Factor for ductility	k ₂ [-]	1,0			
Steel failure without lever arm FZA A4					
Characteristic resistance	V _{Rk,s} [kN]	20,3	29,5	55,0	55,0
Partial safety factor	γ _{Ms} ¹⁾	1,56			
Factor for ductility	k ₂ [-]	1,0			
Steel failure with lever arm FZA A4					
Characteristic bending resistance	M ⁰ _{Rk,s} [Nm]	52,3	91,6	232	232
Partial safety factor	γ _{Ms} ¹⁾	1,56			
Factor for ductility	k ₂ [-]	1,0			
Steel failure without lever arm FZA C					
Characteristic resistance	V _{Rk,s} [kN]	20,3	29,5	55,0	55,0
Partial safety factor	γ _{Ms} ¹⁾	1,25			
Factor for ductility	k ₂ [-]	1,0			
Steel failure with lever arm FZA C					
Characteristic bending resistance	M ⁰ _{Rk,s} [Nm]	52,3	91,6	232	232
Partial safety factor	γ _{Ms} ¹⁾	1,25			
Factor for ductility	k ₂ [-]	1,0			
Concrete pryout failure FZA, FZA A4, FZA C					
Factor k according to ETAG 001, Annex C or k ₃ according to CEN/TS 1992-4	k = k ₃ [-]	2,0			
Concrete edge failure					
Effective length of anchor in shear loading	l _f [mm]	60	80	100	125
Effective diameter of anchor	d _{nom} [mm]	14	18	22	22
Installation safety factor	γ ₂ = γ _{inst}	1,0			

¹⁾ In absence of other national regulations

fischer-Zykon-Anchor FZA, FZA-D , FZA-I, FZA ST

Performances

Characteristic values of resistance under shear loads for bolt projecting anchor FZA

Annex C7

Table C8: Characteristic values of **shear** resistance under static and quasi-static action for **through bolt anchor FZA D** (Design method A, according to **ETAG 001, Annex C** or **CEN/TS 1992-4:2009**)

Type of anchor / size		FZA D (through bolt anchor)			
		12x50 M8D/10	12x60 M8D/10	12x80 M8D/30	14x80 M10D/20
Steel failure without lever arm FZA D galvanized / hot-dip galvanized					
Characteristic resistance	$V_{Rk,s}$ [kN]	14,7	14,7	14,7	23,2
Partial safety factor	$\gamma_{Ms}^{1)}$	1,25			
Factor for ductility	k_2 [-]	1,0			
Steel failure with lever arm FZA D galvanized / hot-dip galvanized					
Characteristic bending resistance	$M_{Rk,s}^0$ [Nm]	30,0	30,0	30,0	59,8
Partial safety factor	$\gamma_{Ms}^{1)}$	1,25			
Factor for ductility	k_2 [-]	1,0			
Steel failure without lever arm FZA D A4					
Characteristic resistance	$V_{Rk,s}$ [kN]	12,8	12,8	12,8	20,3
Partial safety factor	$\gamma_{Ms}^{1)}$	1,56			
Factor for ductility	k_2 [-]	1,0			
Steel failure with lever arm FZA D A4					
Characteristic bending resistance	$M_{Rk,s}^0$ [Nm]	26,2	26,2	26,2	52,3
Partial safety factor	$\gamma_{Ms}^{1)}$	1,56			
Factor for ductility	k_2 [-]	1,0			
Steel failure without lever arm FZA D C					
Characteristic resistance	$V_{Rk,s}$ [kN]	12,8	12,8	12,8	20,3
Partial safety factor	$\gamma_{Ms}^{1)}$	1,25			
Factor for ductility	k_2 [-]	1,0			
Steel failure with lever arm FZA D C					
Characteristic bending resistance	$M_{Rk,s}^0$ [Nm]	26,2	26,2	26,2	52,3
Partial safety factor	$\gamma_{Ms}^{1)}$	1,25			
Factor for ductility	k_2 [-]	1,0			
Concrete pryout failure FZA D, FZA D A4, FZA D C					
Factor k according to ETAG 001, Annex C or k_3 according to CEN/TS 1992-4	$k = k_3$ [-]	1,3	1,3	1,3	2,0
Concrete edge failure					
Effective length of anchor in shear loading	l_f [mm]	40	50	50	60
Effective diameter of anchor	d_{nom} [mm]	12	12	12	14
Installation safety factor	$\gamma_2 = \gamma_{inst}$	1,0			

¹⁾ In absence of other national regulations

fischer-Zykon-Anchor FZA, FZA-D , FZA-I, FZA ST

Performances

Characteristic values of resistance under shear loads for through bolt anchor FZA D

Annex C8

Table C9: Characteristic values of **shear** resistance under static and quasi-static action **for through bolt anchor FZA D** (Design method A, according to **ETAG 001, Annex C or CEN/TS 1992-4:2009**)

Type of anchor / size	FZA D (through bolt anchor)				
	14x100 M10D/40	18x100 M12D/20	18x130 M12D/50	22x125 M16D/25	
Steel failure without lever arm FZA D galvanized / hot-dip galvanized					
Characteristic resistance	$V_{Rk,s}$ [kN]	23,2	33,8	33,8	62,8
Partial safety factor	$\gamma_{Ms}^{1)}$	1,25			
Factor for ductility	k_2 [-]	1,0			
Steel failure with lever arm FZA D galvanized / hot-dip galvanized					
Characteristic bending resistance	$M_{Rk,s}^0$ [Nm]	59,8	105	105	266
Partial safety factor	$\gamma_{Ms}^{1)}$	1,25			
Factor for ductility	k_2 [-]	1,0			
Steel failure without lever arm FZA D A4					
Characteristic resistance	$V_{Rk,s}$ [kN]	20,3	29,5	29,5	55,0
Partial safety factor	$\gamma_{Ms}^{1)}$	1,56			
Factor for ductility	k_2 [-]	1,0			
Steel failure with lever arm FZA D A4					
Characteristic bending resistance	$M_{Rk,s}^0$ [Nm]	52,3	91,6	91,6	232
Partial safety factor	$\gamma_{Ms}^{1)}$	1,56			
Factor for ductility	k_2 [-]	1,0			
Steel failure without lever arm FZA D C					
Characteristic resistance	$V_{Rk,s}$ [kN]	20,3	29,5	29,5	55,0
Partial safety factor	$\gamma_{Ms}^{1)}$	1,25			
Factor for ductility	k_2 [-]	1,0			
Steel failure with lever arm FZA D C					
Characteristic bending resistance	$M_{Rk,s}^0$ [Nm]	52,3	91,6	91,6	232
Partial safety factor	$\gamma_{Ms}^{1)}$	1,25			
Factor for ductility	k_2 [-]	1,0			
Concrete pryout failure FZA D, FZA D A4, FZA D C					
Factor k according to ETAG 001, Annex C or k_3 according to CEN/TS 1992-4	$k = k_3$ [-]	2,0			
Concrete edge failure					
Effective length of anchor in shear loading	l_f [mm]	60	80	80	100
Effective diameter of anchor	d_{nom} [mm]	14	18	18	22
Installation safety factor	$\gamma_2 = \gamma_{inst}$	1,0			

¹⁾ In absence of other national regulations

fischer-Zykon-Anchor FZA, FZA-D , FZA-I, FZA ST

Performances

Characteristic values of resistance under shear loads for through bolt anchor FZA D

Annex C9

Table C10: Characteristic values of **shear** resistance under static and quasi-static action **internal thread anchor FZA I** (Design method A, according to **ETAG 001, Annex C** or **CEN/TS 1992-4:2009**)

Type of anchor / size	FZA I (internal thread anchor)						
	12x40 M6 I	12x50 M6 I	14x60 M8 I	18x80 M10 I	22x100 M12 I	22x125 M12 I	
Steel failure without lever arm FZA I							
Characteristic resistance	$V_{Rk,s}$ [kN]	8,6	8,6	11,4	13,4	31,5	31,5
Partial safety factor	$\gamma_{Ms}^{1)}$	1,5	1,5	1,5	1,7	1,7	1,7
Factor for ductility	k_2 [-]	1,0					
Steel failure with lever arm FZA I							
Characteristic bending resistance	$M_{Rk,s}^0$ [Nm]	12,2	12,2	30,0	59,8	105	105
Partial safety factor	$\gamma_{Ms}^{1)}$	1,25					
Factor for ductility	k_2 [-]	1,0					
Steel failure without lever arm FZA I A4							
Characteristic resistance	$V_{Rk,s}$ [kN]	6,7	6,7	9,0	11,3	26,6	26,6
Partial safety factor	$\gamma_{Ms}^{1)}$	1,5					
Factor for ductility	k_2 [-]	1,0					
Steel failure with lever arm FZA I A4							
Characteristic bending resistance	$M_{Rk,s}^0$ [Nm]	10,7	10,7	26,2	52,3	91,6	91,6
Partial safety factor	$\gamma_{Ms}^{1)}$	1,56					
Factor for ductility	k_2 [-]	1,0					
Steel failure without lever arm FZA I C							
Characteristic resistance	$V_{Rk,s}$ [kN]	6,7	6,7	9,0	11,3	26,6	26,6
Partial safety factor	$\gamma_{Ms}^{1)}$	1,5					
Factor for ductility	k_2 [-]	1,0					
Steel failure with lever arm FZA I C							
Characteristic bending resistance	$M_{Rk,s}^0$ [Nm]	10,7	10,7	26,2	52,3	91,6	91,6
Partial safety factor	$\gamma_{Ms}^{1)}$	1,56					
Factor for ductility	k_2 [-]	1,0					
Concrete pryout failure FZA I, FZA I A4, FZA I C							
Factor k according to ETAG 001, Annex C or k_3 according to CEN/TS 1992-4	$k = k_3$ [-]	1,3	1,3	2,0	2,0	2,0	2,0
Concrete edge failure							
Effective length of anchor in shear loading	l_f [mm]	40	50	60	80	100	125
Effective diameter of anchor	d_{nom} [mm]	12	12	14	18	22	22
Installation safety factor	$\gamma_2 = \gamma_{inst}$	1,0					

¹⁾ In absence of other national regulations

fischer-Zykon-Anchor FZA, FZA-D , FZA-I, FZA ST

Performances

Characteristic values of resistance under shear loads for internal thread anchor FZA I

Annex C10

Table C11: Characteristic values of **tension and shear** resistance under **seismic action** for **bolt projecting anchor FZA** (Design according to **TR 045: Performance category C1**)

Type of anchor / size	FZA (bolt projecting anchor)					
	14x40 M10 / t _{fix}	14x60 M10 / t _{fix}	18x80 M12 / t _{fix}	22x100 M16 / t _{fix}	22x125 M16 / t _{fix}	
Steel failure FZA galvanized						
Characteristic resistance tension load C1	$N_{Rk,s,C1}$ [kN]	46,4	46,4	67,4	126	126
Partial safety factor	$\gamma_{Ms,C1}^{1)}$ [-]	1,5				
Steel failure FZA hot-dip galvanized						
Characteristic resistance tension load C1	$N_{Rk,s,C1}$ [kN]	40,7	40,7	60,1	115	115
Partial safety factor	$\gamma_{Ms,C1}^{1)}$ [-]	1,5				
Steel failure FZA A4						
Characteristic resistance tension load C1	$N_{Rk,s,C1}$ [kN]	40,6	40,6	59,0	110	110
Partial safety factor	$\gamma_{Ms,C1}^{1)}$ [-]	1,87				
Steel failure FZA C						
Characteristic resistance tension load C1	$N_{Rk,s,C1}$ [kN]	40,6	40,6	59,0	110	110
Partial safety factor	$\gamma_{Ms,C1}^{1)}$ [-]	1,5				
Pullout failure						
Characteristic resistance tension load in cracked concrete C1	$N_{Rk,p,C1}$ [kN]	6,0	6,0	20,0	40,0	40,0
Installation safety factor	$\gamma_{2,C1}$ [-]	1,0				
Steel failure without lever arm FZA						
Characteristic resistance shear load C1	$V_{Rk,s,C1}$ [kN]	20,9	20,9	33,8	62,8	62,8
Partial safety factor	$\gamma_{Ms,C1}^{1)}$ [-]	1,25				
Steel failure without lever arm FZA A4						
Characteristic resistance shear load C1	$V_{Rk,s,C1}$ [kN]	18,3	18,3	29,5	55,0	55,0
Partial safety factor	$\gamma_{Ms,C1}^{1)}$ [-]	1,56				
Steel failure without lever arm FZA C						
Characteristic resistance shear load C1	$V_{Rk,s,C1}$ [kN]	18,3	18,3	29,5	55,0	55,0
Partial safety factor	$\gamma_{Ms,C1}^{1)}$ [-]	1,25				

¹⁾ In absence of other national regulations

fischer-Zykon-Anchor FZA, FZA-D , FZA-I, FZA ST

Performances

Characteristic values of tension and shear resistance under seismic action for bolt projecting anchor FZA

Annex C11

Table C12: Characteristic values of **tension and shear** resistance under **seismic action for through bolt anchor FZA D** (Design according to **TR 045: Performance category C1**)

Type of anchor / size	FZA D (through bolt anchor)					
	14x80 M10D/20	14x100 M10D/40	18x100 M12D/20	18x130 M12D/50	22x125 M16D/25	
Steel failure FZA D galvanized						
Characteristic resistance tension load C1	$N_{Rk,s,C1}$ [kN]	46,4	46,4	67,4	67,4	126
Partial safety factor	$\gamma_{Ms,C1}^{1)}$ [-]	1,5				
Steel failure FZA D hot-dip galvanized						
Characteristic resistance tension load C1	$N_{Rk,s,C1}$ [kN]	40,7	40,7	60,1	60,1	115
Partial safety factor	$\gamma_{Ms,C1}^{1)}$ [-]	1,5				
Steel failure FZA D A4						
Characteristic resistance tension load C1	$N_{Rk,s,C1}$ [kN]	40,6	40,6	59,0	59,0	110
Partial safety factor	$\gamma_{Ms,C1}^{1)}$ [-]	1,87				
Steel failure FZA D C						
Characteristic resistance tension load C1	$N_{Rk,s,C1}$ [kN]	40,6	40,6	59,0	59,0	110
Partial safety factor	$\gamma_{Ms,C1}^{1)}$ [-]	1,5				
Pullout failure						
Characteristic resistance tension load in cracked concrete C1	$N_{Rk,p,C1}$ [kN]	6,0	6,0	20,0	20,0	40,0
Installation safety factor	$\gamma_{2,C1}$ [-]	1,0				
Steel failure without lever arm FZA D						
Characteristic resistance shear load C1	$V_{Rk,s,C1}$ [kN]	20,9	20,9	33,8	33,8	62,8
Partial safety factor	$\gamma_{Ms,C1}^{1)}$ [-]	1,25				
Steel failure without lever arm FZA D A4						
Characteristic resistance shear load C1	$V_{Rk,s,C1}$ [kN]	18,3	18,3	29,5	29,5	55,0
Partial safety factor	$\gamma_{Ms,C1}^{1)}$ [-]	1,56				
Steel failure without lever arm FZA D C						
Characteristic resistance shear load C1	$V_{Rk,s,C1}$ [kN]	18,3	18,3	29,5	29,5	55,0
Partial safety factor	$\gamma_{Ms,C1}^{1)}$ [-]	1,25				

¹⁾ In absence of other national regulations

fischer-Zykon-Anchor FZA, FZA-D , FZA-I, FZA ST

Performances

Characteristic values of tension and shear resistance under seismic action for through bolt anchor FZA D

Annex C12

Table C13: Displacements due to tension loads for **bolt projecting anchor FZA** (Design method A, according to **ETAG 001, Annex C** or **CEN/TS 1992-4:2009**)

Type of anchor / size		FZA (bolt projecting anchor)			
		10x40 M6 / t _{fix}	12x40 M8 / t _{fix}	14x40 M10 / t _{fix}	12x50 M8 / t _{fix}
Tension load in cracked concrete	N [kN]	2,0	2,0	2,0	3,5
Displacement	δ _{N0} [mm]	0,8			
	δ _{N∞} [mm]	1,1			
Tension load in non - cracked concrete	N [kN]	3,3	3,3	3,3	4,8
Displacement	δ _{N0} [mm]	0,8			
	δ _{N∞} [mm]	1,1			
		14x60 M10 / t _{fix}	18x80 M12 / t _{fix}	22x100 M16 / t _{fix}	22x125 M16 / t _{fix}
		Tension load in cracked concrete	N [kN]	5,0	8,0
Displacement	δ _{N0} [mm]	0,8			
	δ _{N∞} [mm]	1,1			
Tension load in non - cracked concrete	N [kN]	7,5	12,7	17,9	17,9
Displacement	δ _{N0} [mm]	0,8			
	δ _{N∞} [mm]	1,1			

The displacements do not apply for FZA ST

Table C14: Displacements due to tension loads for **through bolt anchor FZA D** (Design method A, according to **ETAG 001, Annex C** or **CEN/TS 1992-4:2009**)

Type of anchor / size		FZA (through bolt anchor FZA D)			
		12x50 M8D/10	12x60 M8D/10	12x80 M8D/30	14x80 M10D/20
Tension load in cracked concrete	N [kN]	2,0	3,5	3,5	5,0
Displacement	δ _{N0} [mm]	0,8			
	δ _{N∞} [mm]	1,1			
Tension load in non - cracked concrete	N [kN]	3,3	4,8	4,8	7,5
Displacement	δ _{N0} [mm]	0,8			
	δ _{N∞} [mm]	1,1			
		14x100 M10D/40	18x100 M12D/20	18x130 M12D/50	22x125 M16D/25
		Tension load in cracked concrete	N [kN]	5,0	8,0
Displacement	δ _{N0} [mm]	0,8			
	δ _{N∞} [mm]	1,1			
Tension load in non - cracked concrete	N [kN]	7,5	12,7	12,7	17,9
Displacement	δ _{N0} [mm]	0,8			
	δ _{N∞} [mm]	1,1			

fischer-Zykon-Anchor FZA, FZA-D , FZA-I, FZA ST

Performances

Displacements due to tension loads for bolt projecting anchor FZA and through bolt anchor FZA D

Annex C13

Table C15: Displacements due to tension loads for **internal thread anchor FZA I**
(Design method A, according to **ETAG 001, Annex C** or **CEN/TS 1992-4:2009**)

Type of anchor / size			FZA I (internal thread anchor FZA I)					
			12x40 M6 I	12x50 M6 I	14x60 M8 I	18x80 M10 I	22x100 M12 I	22x125 M12 I
Tension load in cracked concrete	N	[kN]	2,0	3,5	5,0	8,0	16,0	16,0
Displacement	δ_{N0}	[mm]	0,8					
	$\delta_{N\infty}$	[mm]	1,1					
Tension load in non - cracked concrete	N	[kN]	3,3	4,8	7,5	12,7	17,9	17,9
Displacement	δ_{N0}	[mm]	0,8					
	$\delta_{N\infty}$	[mm]	1,1					

fischer-Zykon-Anchor FZA, FZA-D , FZA-I, FZA ST

Performances
Displacements due to tension loads for internal thread anchor FZA I

Annex C14

Table C16: Displacements due to shear loads for **bolt projecting anchor FZA** (Design method A, according to **ETAG 001, Annex C** or **CEN/TS 1992-4:2009**)

Type of anchor / size		FZA (bolt projecting anchor)			
		10x40 M6 / t _{fix}	12x40 M8 / t _{fix}	14x40 M10 / t _{fix}	12x50 M8 / t _{fix}
Shear load in cracked and non-cracked concrete	V [kN]	4,0	5,0	9,0	5,0
Displacement	δ _{V0} [mm]	2,0	0,7	1,9	0,7
	δ _{V∞} [mm]	3,0	1,0	2,8	1,0
		14x60 M10 / t _{fix}	18x80 M12 / t _{fix}	22x100 M16 / t _{fix}	22x125 M16 / t _{fix}
Shear load in cracked and non-cracked concrete	V [kN]	12,5	19,0	30,0	30,0
Displacement	δ _{V0} [mm]	1,9	2,1	2,1	2,1
	δ _{V∞} [mm]	2,8	3,1	3,1	3,1

The displacements do not apply for FZA ST

Table C17: Displacements due to shear loads for **through bolt anchor FZA D** (Design method A, according to **ETAG 001, Annex C** or **CEN/TS 1992-4:2009**)

Type of anchor / size		FZA D (through bolt anchor)			
		12x50 M8D/10	12x60 M8D/10	12x80 M8D/30	14x80 M10D/20
Shear load in cracked and non-cracked concrete	V [kN]	5,0	5,0	5,0	12,5
Displacement	δ _{V0} [mm]	0,7	0,7	0,7	1,9
	δ _{V∞} [mm]	1,0	1,0	1,0	2,8
		14x100 M10D/40	18x100 M12D/20	18x130 M12D/50	22x125 M16D/25
Shear load in cracked and non-cracked concrete	V [kN]	12,5	19,0	19,0	30,0
Displacement	δ _{V0} [mm]	1,9	2,1	2,1	2,1
	δ _{V∞} [mm]	2,8	3,1	3,1	3,1

Table C18: Displacements due to shear loads for **internal thread anchor FZA I** (Design method A, according to **ETAG 001, Annex C** or **CEN/TS 1992-4:2009**)

Type of anchor / size		FZA I (internal thread anchor)					
		12x40 M6 I	12x50 M6 I	14x60 M8 I	18x80 M10 I	22x100 M12 I	22x125 M12 I
Shear load in cracked and non-cracked concrete	V [kN]	5,0	5,0	12,5	19,0	30,0	30,0
Displacement	δ _{N0} [mm]	0,7	0,7	1,9	2,1	2,1	2,1
	δ _{N∞} [mm]	1,0	1,0	2,8	3,1	3,1	3,1

fischer-Zykon-Anchor FZA, FZA-D , FZA-I, FZA ST

Performances
Displacements due to shear loads

Annex C15