



## DICHIARAZIONE DI PRESTAZIONE

### DoP 0291

per ancorante a percussione fischer EA II (ancorante meccanico per l'utilizzo nel calcestruzzo)

IT

1. Codice di identificazione unico del prodotto-tipo: DoP 0291
2. Usi previsti: Fissaggio post-installato in calcestruzzo non fessurato, vedi appendice, in particolare gli allegati da B1-B3.
3. Fabbricante: fischerwerke GmbH & Co. KG, Klaus-Fischer-Str. 1, 72178 Waldachtal, Germany
4. Mandatario: -
5. Sistemi di VVCP: 1
6. Documento per la valutazione europea: EAD 330232-01-0601  
Valutazione tecnica europea: ETA-07/0135; 2021-10-20  
Organismo di valutazione tecnica: DIBt- Deutsches Institut für Bautechnik  
Organismi notificati: 2873 TU Darmstadt
7. Prestazioni dichiarate:  
**Resistenza meccanica e stabilità (BWR 1)**  
**Resistenza caratteristica al carico di tensione (carico statico e quasi-statico) Metodo A:**  
Resistenza alla rottura dell'acciaio: Allegato C1  
Resistenza alla rottura per sfilamento: Allegato C1  
Resistenza alla rottura del cono di calcestruzzo: Allegato C1  
Robustezza: Allegato C1  
Distanza dal bordo e interassi minimi: Allegato B2  
Distanza dal bordo per evitare lo splitting sotto carico: Allegato C1  
  
**Resistenza caratteristica al carico di taglio (carico statico e quasi statico), metodo A:**  
Resistenza alla rottura dell'acciaio (carico di taglio): Allegato C2  
Resistenza alla rottura per pry-out: Allegato C2  
  
**Resistenza caratteristica per una progettazione semplificata:**  
Metodo B: NPD  
Metodo C: NPD  
  
**Spostamenti:**  
Spostamenti sotto azioni statiche e quasi statiche: Allegato C3  
  
**Resistenza e spostamenti caratteristici per le categorie di prestazione sismica C1 e C2:**  
Resistenza al carico di trazione, spostamenti, categoria C1: NPD  
Resistenza al carico di trazione, spostamenti, categoria C2: NPD  
Resistenza al carico di taglio, spostamenti, categoria C1: NPD  
Resistenza al carico di taglio, spostamenti, categoria C2: NPD  
Fattore spazio anulare: NPD  
  
**Sicurezza in caso di incendio (BWR 2)**  
Reazione al fuoco: Classe (A1)  
  
**Resistenza al fuoco:**  
Resistenza al fuoco alla rottura dell'acciaio (carico di trazione): NPD  
Resistenza al fuoco alla rottura per sfilamento (carico di trazione): NPD  
Resistenza al fuoco alla rottura dell'acciaio (carico di taglio): NPD  
  
**Durabilità:**  
Durabilità: Allegati A3, B1
8. Documentazione tecnica appropriata e/o documentazione tecnica specifica: -



La prestazione del prodotto sopra identificato è conforme all'insieme delle prestazioni dichiarate. La presente dichiarazione di prestazione è emessa, in conformità al regolamento (UE) n. 305/2011, sotto la sola responsabilità del fabbricante sopra identificato.

Firmato a nome e per conto del fabbricante da:



Dr.-Ing. Oliver Geibig, Direttore Generale Unità di Business & Engineering  
Tumlingen, 2021-10-27



Jürgen Grün, Direttore Generale Chimica & Qualità

Questa Dichiarazione di Prestazione (DoP) è stata preparata in varie lingue. In caso di contestazioni sull'interpretazione, prevarrà sempre la versione inglese.

L'Appendice include informazioni volontarie e complementari in lingua inglese che superano i requisiti di legge (lingua specificata in modo neutrale).

## Specific Part

### 1 Technical description of the product

The Fischer drop-in anchor EA II is an anchor made of galvanized or stainless steel which is placed into a drilled hole and anchored by deformation-controlled expansion.

The fixture shall be anchored with a fastening screw or threaded rod.

The product description is given in Annex A.

### 2 Specification of the intended use in accordance with the applicable European Assessment Document

The performances given in Section 3 are only valid if the anchor is used in compliance with the specifications and conditions given in Annex B.

The verifications and assessment methods on which this European Technical Assessment is based lead to the assumption of a working life of the anchor of at least 50 years. The indications given on the working life cannot be interpreted as a guarantee given by the producer, but are to be regarded only as a means for choosing the right products in relation to the expected economically reasonable working life of the works.

### 3 Performance of the product and references to the methods used for its assessment

#### 3.1 Mechanical resistance and stability (BWR 1)

Essential characteristic	Performance
Characteristic resistance to tension load (static and quasi static action) Method A	See Annex B2 and C1
Characteristic resistance to shear load (static and quasi static action)	See Annex C2
Displacements and Durability	See Annex C3 and B1
Characteristic resistance and displacements for seismic performance categories C1 and C2	No performance assessed

#### 3.2 Safety in case of fire (BWR 2)

Essential characteristic	Performance
Reaction to fire	Class A1
Resistance to fire	No performance assessed

### 4 Assessment and verification of constancy of performance (AVCP) system applied, with reference to its legal base

In accordance with the European Assessment Document EAD 330232-01-0601 the applicable European legal act is: [96/582/EC].

The system to be applied is: 1

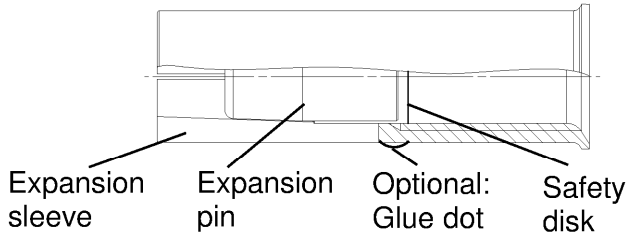
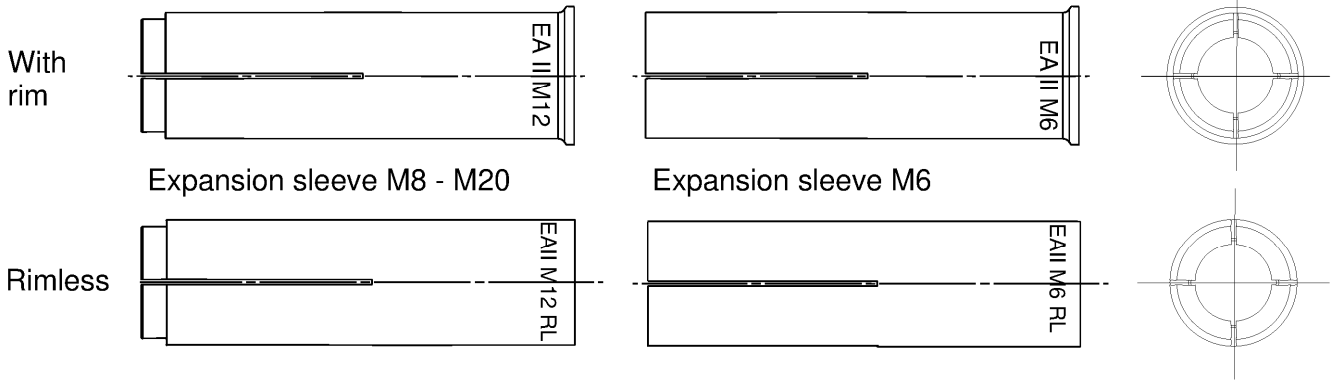

**Intended use in concrete**

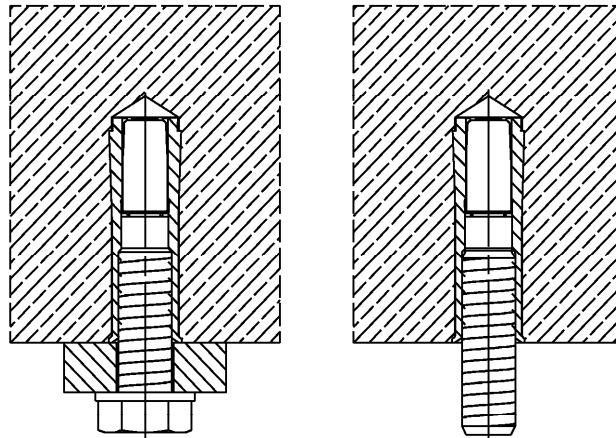

*(Fig. not to scale)*

fischer drop-in anchor EA II

**Product description**  
Anchor types  
Installed condition

**Annex A 1**

Appendix 2 / 11

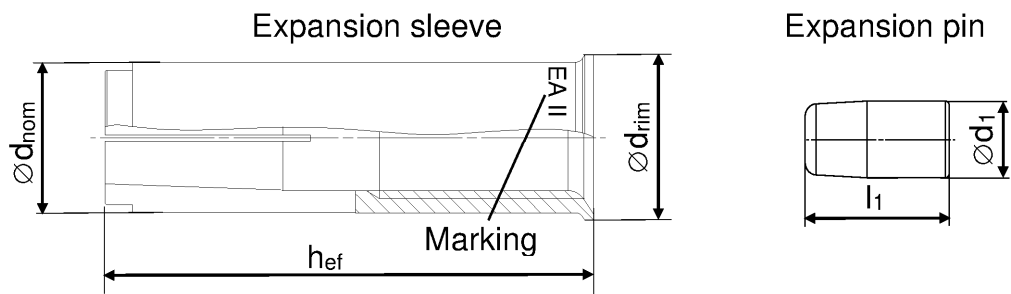

**Table A2.1: Anchor size**

Anchor size EA II [mm]	M6x30	M8x30	M8x40	M10x30	M10x40	M12x50	M12x50 D	M16x65	M20x80
$h_{ef}$	30	30	40	30	40	50		65	80
$\varnothing d_{nom}$	8	10		12		15	16	20	25
$\varnothing d_{rim}$ (not applicable for EA II RL)	9,5	11,5		13,5		16,5	17,5	21,5	27,0
$\varnothing d_1$	5	6,5		8		10		13,5	17,5
$l_1$	14	13,5		13	18	18		25	26

**Distinctive feature**

No groove for:

- EA II M6x30..
- EA II M8x30..
- EA II M10x40..
- EA II M12x50..
- EA II M16x65..
- EA II M20x80..

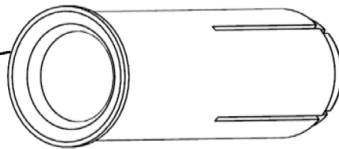

2 grooves for:

- EA II M8x40..
- EA II M10x30..

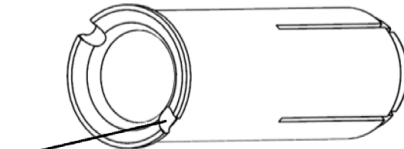

**Table A2.2: Marking on anchor body**

galvanised steel (gvz)		stainless steel (R)	
with rim	rimless	with rim	rimless
EA II M6x30	EA II M6x30 RL	EA II M6x30 R	EA II M6x30 RL R
EA II M8x30	EA II M8x30 RL	EA II M8x30 R	EA II M8x30 RL R
EA II M8x40	EA II M8x40 RL	EA II M8x40 R	EA II M8x40 RL R
EA II M10x30	EA II M10x30 RL	EA II M10x30 R	EA II M10x30 RL R
EA II M10x40	EA II M10x40 RL	EA II M10x40 R	EA II M10x40 RL R
EA II M12x50	EA II M12x50 RL	EA II M12x50 R	EA II M12x50 RL R
EA II M12x50 D	EA II M12x50 RL D	EA II M12x50 D R	EA II M12x50 RL D R
EA II M16x65	EA II M16x65 RL	EA II M16x65 R	EA II M16x65 RL R
EA II M20x80	EA II M20x80 RL	EA II M20x80 R	EA II M20x80 RL R

(Fig. not to scale)

fischer drop-in anchor EA II

**Product description**  
Anchor types

**Annex A 2**

Appendix 3 / 11

Expansion sleeve

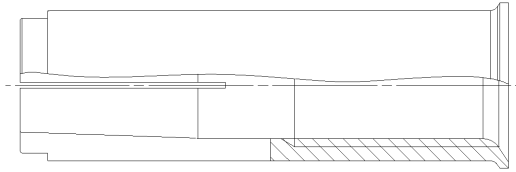

Expansion pin

**Table A3.1: Materials**

Designation	Material	
	galvanised steel ( $\geq 5 \mu\text{m}$ )	stainless steel (R)
Expansion sleeve	EN 10277:2018 or EN 10084:2008 or EN 10111:2008 or EN 10263:2018 or EN 10087:1999 or ASTM A29/A29M	EN 10088:2014
Expansion pin		
Fastening screw or threaded rod	steel, property class 4.6, 5.6, 5.8 or 8.8 according to EN ISO 898-1:2013	property class 50, 70 or 80 according to EN ISO 3506:2020

*(Fig. not to scale)*

fischer drop-in anchor EA II

**Product description**  
Material

**Annex A 3**

Appendix 4 / 11

## Setting & drilling tools

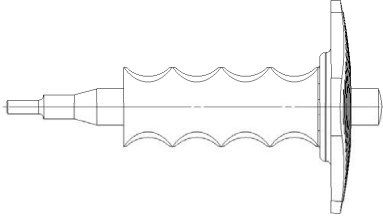
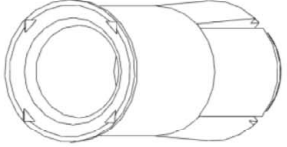
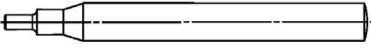
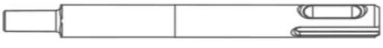
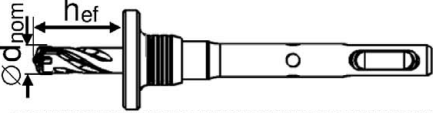
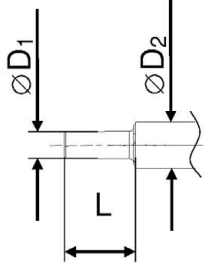
Setting tools	Marking	Description	Marking on EA II with rim and rimless
	EHS Plus M..x hef	Manual setting tool with hand guard	
	EHS M..x hef	Manual setting tool basic format	
	EMS M..x hef	Machine setting tool with SDS Plus	No marking
<b>Drilling tools</b>			
	EBB $\varnothing d_{nom} \times hef$	Stop drill	
Or other usual drill			

**Table A4.1: Corresponding drill bits and parameters of setting tools**

Manual setting tool	Machine setting tool	Stop drill	For anchor size EA II	$\varnothing D1$ [mm]	$\varnothing D2$ [mm]	L [mm]
EHS (Plus) M6x25/30	EMS M6x25/30	EBB 8x30	EA II M6x30	4,8	9,0	17,0
EHS (Plus) M8x25/30	EMS M8x25/30	EBB 10x30	EA II M8x30	6,4	11,0	18,0
EHS (Plus) M8x40	EMS M8x40	EBB 10x40	EA II M8x40			28,0
EHS (Plus) M10x25/30	EMS M10x25/30	EBB 12x30	EA II M10x30	7,9	13,0	18,0
EHS (Plus) M10x40	EMS M10x40	EBB 12x40	EA II M10x40			24,0
EHS (Plus) M12x50	EMS M12x50	EBB 15x50	EA II M12x50	10,2	16,5	30,0
EHS (Plus) M12x50	EMS M12x50	EBB 16x50	EA II M12x50 D			
EHS (Plus) M16x65	EMS M16x65	EBB 20x65	EA II M16x65	13,5	22	36,0
EHS (Plus) M20x80	EMS M20x80	EBB 25x80	EA II M20x80	16,4	27	50,0

(Fig. not to scale)

fischer drop-in anchor EA II



**Intended Use**  
Setting & Drilling tools

**Annex A 4**

Appendix 5 / 11

## Specifications of intended use

### Anchorage subject to:

fischer drop-in anchor EA II (all versions)	M6	M8	M10	M12	M16	M20
Hammer drilling with standard drill bit 	All types					
Hammer drilling with hollow drill bit with automatic cleaning 						
Material	Steel	Zinc plated	✓			
	Stainless	R				
Static and quasi-static loads			✓			
Uncracked concrete			✓			

### Base materials:

- Reinforced or unreinforced normal concrete without fibres of strength classes C20/25 to C50/60 according to EN 206:2013+A1:2016

### Use conditions (Environmental conditions):

- Structures subject to dry internal conditions: **EA II, EA II R**
- For all other conditions according to EN 1993-1-4:2006 + A1:2015 corresponding to corrosion resistance class CRC III **EA II R**  
Anchor types M6x30 R, M8x30 R and M10x30 R only for dry internal exposure

### Design:

- Anchorage are to be designed under the responsibility of an engineer experienced in anchorages and concrete work
- Verifiable calculation notes and drawings are to be prepared taking account of the loads to be anchored. The position of the anchor is indicated on the design drawings (e.g. position of the anchor relative to reinforcement or to supports, etc.)
- Design of fastenings according to EN 1992-4:2018 and Technical Report TR 055, Edition February 2018
- Anchor sizes M6x30, M8x30 and M10x30 for statically indeterminate structural components only, when in case of failure, the load can be distributed to other fasteners.

### Installation:

- Anchor installation carried out by appropriately qualified personnel and under the supervision of the person responsible for technical matters of the site
- Create drill hole with hammer drill or with hollow drill and vacuum cleaner
- The anchor may only be used once
- In case of aborted hole: New hole must be drilled at a minimum distance of twice the depth of the aborted hole or closer, if the hole is filled with a high strength mortar (e.g. FIS EM Plus, FIS SB or FIS V Plus) and only if the hole is not in the direction of the oblique tensile or shear load
- Anchor expansion by impact using the setting tools given in Annex A 4. The anchor is properly set if the stop of the setting tool reaches the expansion sleeve. The manual setting tool with installation control leaves a visible mark on the sleeve, as illustrated in Annex A 4 and B 3

fischer drop-in anchor EA II

**Intended Use**  
Specifications

**Annex B 1**

Appendix 6 / 11

**Table B2.1: Installation parameters for concrete C20/25 to C50/60**

Anchor size (all versions)			M6x30	M8x30	M8x40	M10x30	M10x40	M12x50	M12x50 D	M16x65	M20x80
Nominal drill hole diameter	$d_0$	[mm]	8	10		12		15	16	20	25
Cutting diameter of drill bit	$d_{cut}$		8,45	10,45		12,50		15,50	16,50	20,55	25,55
Effective anchorage depth	$h_{ef}$		30	30	40	30	40	50		65	80
Maximum installation torque	$T_{inst,max}$	[Nm]	4	8		15		35	60	120	
Minimum drill hole depth	$h_1$	[mm]	32	33	43	33	43	54	70	85	
Minimum screw-in depth	$l_{s,min}$		6	8		10		12	16	20	
Maximum screw-in depth	$l_{s,max}$		14	14		15	17	22	28	34	
Clearance of hole diameter	$\varnothing d_f \leq$		7	9		12		14	18	22	
<b><math>h_{min} = 80</math> mm</b>											
Minimum spacing	$S_{min}$	[mm]	70	110	200	200		-1)			
Minimum edge distance	$C_{min}$		150	150		150					
<b><math>h_{min} = 100</math> mm</b>											
Minimum spacing	$S_{min}$	[mm]	65	70	90	150	200		-1)		
Minimum edge distance	$C_{min}$		115	115		160					
<b><math>h_{min} = 120</math> mm</b>											
Minimum spacing	$S_{min}$	[mm]	65	70	85	95	145		-1)		
Minimum edge distance	$C_{min}$		115	115		140					
<b><math>h_{min} = 160</math> mm</b>											
Minimum spacing	$S_{min}$	[mm]	65	70	85	95	145		180	-1)	
Minimum edge distance	$C_{min}$		115	115		140			150		
<b><math>h_{min} = 200</math> mm</b>											
Minimum spacing	$S_{min}$	[mm]	65	70	85	95	145		180	190	-1)
Minimum edge distance	$C_{min}$		115	115		140			150	200	

<sup>1)</sup> No performance assessed

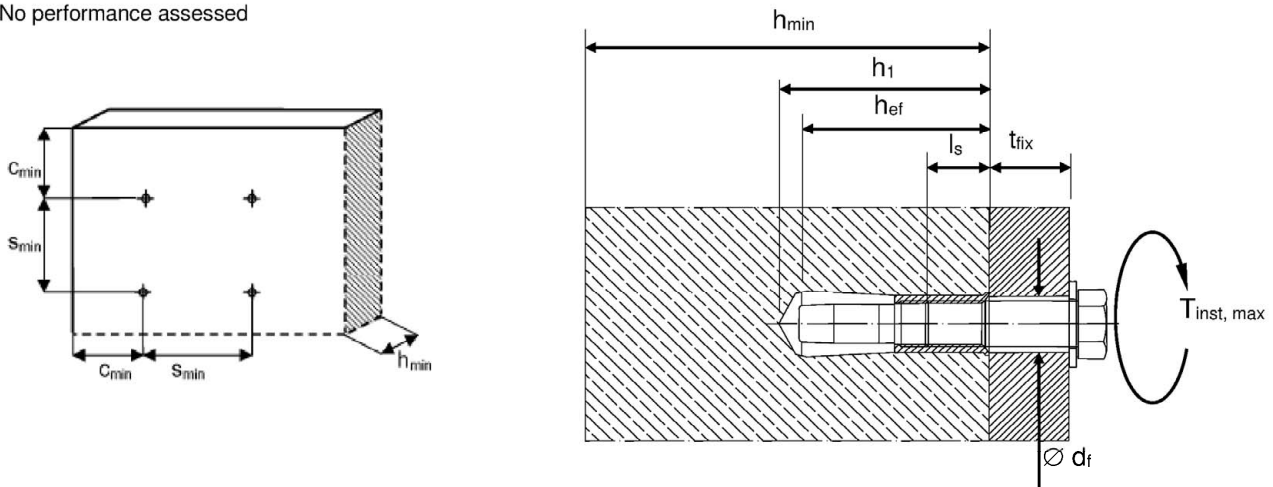

Fastening screw or threaded rod:

- Minimum property class and materials according to table A3.1
- The length of the fastening screw or threaded rod shall be determined depending on thickness of fixture  $t_{fix}$ , admissible tolerances and maximum screw-in depth  $l_{s,max}$  as well as minimum screw-in depth  $l_{s,min}$

(Fig. not to scale)

fischer drop-in anchor EA II

**Intended Use**  
Installation parameters

**Annex B 2**

Appendix 7 / 11

## Installation instructions

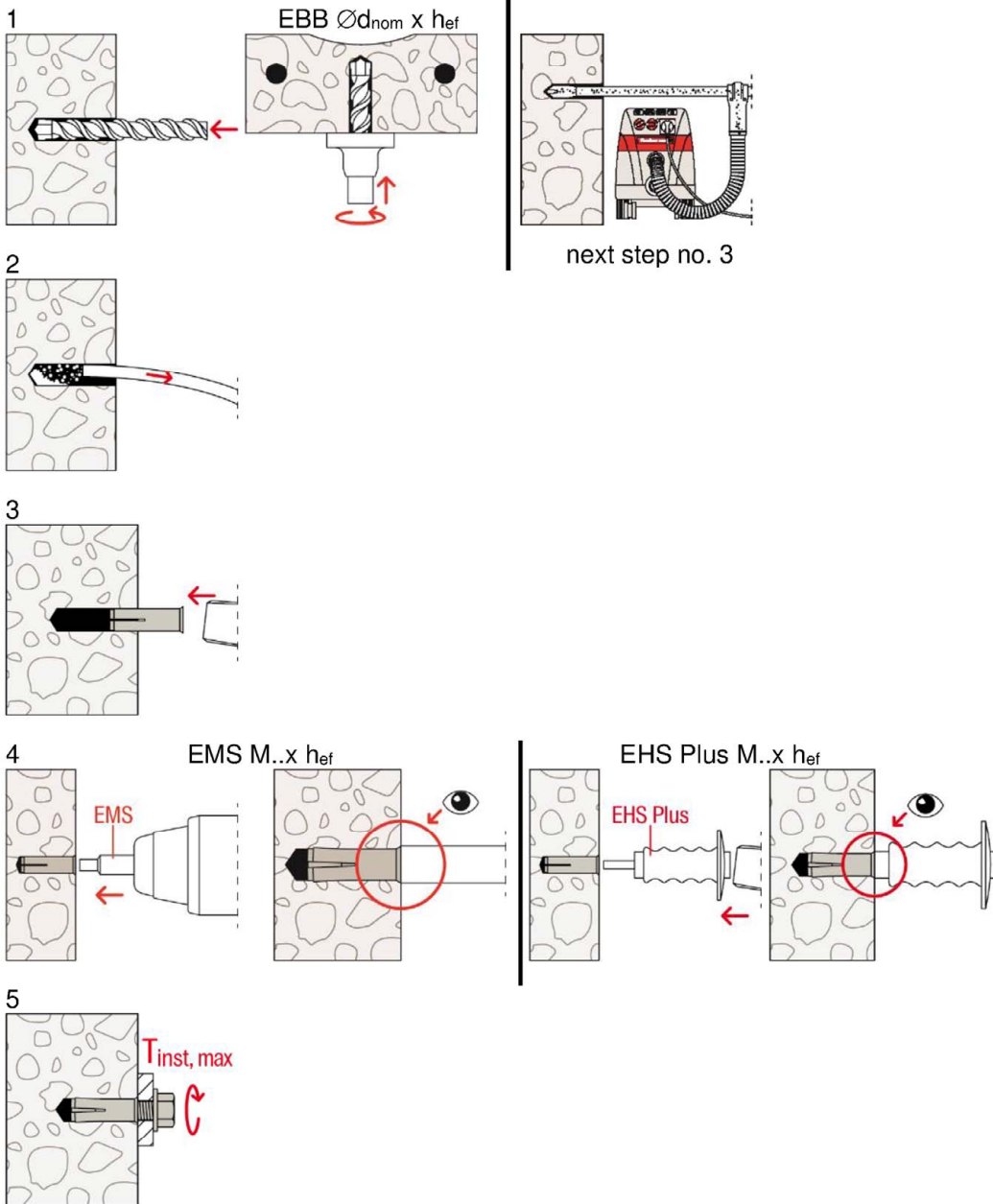

No.	Description
1	Create drill hole with hammer drill or stop drill or with hollow drill and vacuum cleaner (e.g. fischer FVC)
2	Clean from drill-dust
3	Set anchor till anchor is flush with surface of concrete
4	Expand the sleeve by driving the pin with the corresponding setting tool into the sleeve and control the correct setting
5	Fixation of fixture. Maximum installation torque $T_{\text{inst,max}}$ must not be exceeded

fischer drop-in anchor EA II

**Intended Use**  
Installation instructions

**Annex B 3**

Appendix 8 / 11

**Table C1.1:** Characteristic values for tension loads under static and quasi-static action

EA II	property class of the fastening screw or threaded rod		M6x30 <sup>1)</sup>	M8x30 <sup>1)</sup>	M8x40	M10x30 <sup>1)</sup>	M10x40	M12x50	M12x50 D	M16x65	M20x80
			<b>Steel failure</b>								
Installation factor	$\gamma_{inst}$	[-]	1,0								
Characteristic resistance	$N_{Rk,s}$	[kN]	A4-50	10,1	18,3	29,0	42,1	78,3	122,4		
Partial factor	$\gamma_{Ms}^{4)}$	[-]	2,86								
Characteristic resistance	$N_{Rk,s}$	[kN]	A4-70	14,1	19,6	24,9	45,1	59,0	73,8	117,2	
Partial factor	$\gamma_{Ms}^{4)}$	[-]	1,87	1,5				1,87	1,5		
Characteristic resistance	$N_{Rk,s}$	[kN]	A4-80	16,1	19,6	24,9	45,1	59,0	73,8	117,2	
Partial factor	$\gamma_{Ms}^{4)}$	[-]	1,6	1,5							
Characteristic resistance	$N_{Rk,s}$	[kN]	steel 4.6	8,0	14,6	23,2	33,7	62,7	97,9		
Partial factor	$\gamma_{Ms}^{4)}$	[-]	2,0								
Characteristic resistance	$N_{Rk,s}$	[kN]	steel 5.6	10,1	18,3	29,0	42,1	78,3	122,4		
Partial factor	$\gamma_{Ms}^{4)}$	[-]	2,0								
Characteristic resistance	$N_{Rk,s}$	[kN]	steel 5.8	10,1	17,2	21,8	39,6	42,1	64,7	102,8	
Partial factor	$\gamma_{Ms}^{4)}$	[-]	1,5								
Characteristic resistance	$N_{Rk,s}$	[kN]	steel 8.8	13,5	17,2	21,8	39,6	53,3	64,7	102,8	
Partial factor	$\gamma_{Ms}^{4)}$	[-]	1,5								
<b>Pullout failure</b>											
Characteristic resistance C20/25	$N_{Rk,p}$	[kN]	8,1	12,5	8,1	12,5	17,4	25,8	35,2		
Increasing Factors for $N_{Rk,p}$	$\psi_c$	C25/30	1,12								
		C30/37	1,22								
		C35/45	1,32								
		C40/50	1,41								
		C45/55	1,50								
		C50/60	1,58								
Installation factor	$\gamma_{inst}$	[-]	1,0								
<b>Concrete cone and splitting failure</b>											
Effective anchorage depth	$h_{ef}$	[mm]	30	40	30	40	50	65	80		
Factor for uncracked concrete	$k_{ucr,N}$	[-]	11,0 <sup>2)</sup>								
Factor for cracked concrete	$k_{cr,N}$	[-]	No performance assessed								
Spacing	$s_{cr,N}$	[mm]	90	120	90	120	150	195	240		
Edge distance	$c_{cr,N}$	[mm]	45	60	45	60	75	97	120		
Spacing (splitting failure)	$s_{cr,sp}$	[mm]	210	280	210	320	350	455	560		
Edge distance (splitting failure)	$c_{cr,sp}$	[mm]	105	140	105	160	175	227	280		
Characteristic resistance to splitting	$N_{Rk,sp}^0$	[kN]	$\min \{N_{Rk,c}^0, N_{Rk,p}\}^{3)}$								

<sup>1)</sup> Use restricted to anchoring of structural components which are statically indeterminate

<sup>2)</sup> Based on concrete strength as cylinder strength

<sup>3)</sup>  $N_{Rk,c}^0$  according to EN 1992-4:2018

<sup>4)</sup> In absence of other national regulations

fischer drop-in anchor EA II

**Performances**

Characteristic resistance to tension loads under static and quasi-static action

**Annex C 1**

Appendix 9 / 11

**Table C2.1: Characteristic values for shear loads under static and quasi-static action**

EA II	property class of the fastening screw or threaded rod		M6x30 <sup>1)</sup>	M8x30 <sup>1)</sup>	M8x40	M10x30 <sup>1)</sup>	M10x40	M12x50	M12x50 D	M16x65	M20x80
			Factor for ductility	$k_7$ [-]		1,0					
Installation factor	$\gamma_{inst}$ [-]		1,0								
<b>Steel failure without lever arm</b>											
Characteristic resistance	$V_{Rk,s}^0$ [kN]	A4-50	5,0	9,2	14,5	21,1	39,2	61,2			
Partial factor	$\gamma_{Ms}^{(2)}$ [-]		2,38								
Characteristic resistance	$V_{Rk,s}^0$ [kN]	A4-70	7,0	9,8	12,4	22,6	29,5	37	59		
Partial factor	$\gamma_{Ms}^{(2)}$ [-]		1,56	1,25				1,56	1,25		
Characteristic resistance	$V_{Rk,s}^0$ [kN]	A4-80	8,0	9,8	12,4	22,6	30,4	36,9	58,6		
Partial factor	$\gamma_{Ms}^{(2)}$ [-]		1,33	1,25							
Characteristic resistance	$V_{Rk,s}^0$ [kN]	steel 4.6	4,0	7,3	11,6	16,9	31	49			
Partial factor	$\gamma_{Ms}^{(2)}$ [-]		1,67								
Characteristic resistance	$V_{Rk,s}^0$ [kN]	steel 5.6	5,0	9,2	14,5	21,1	39	61			
Partial factor	$\gamma_{Ms}^{(2)}$ [-]		1,67								
Characteristic resistance	$V_{Rk,s}^0$ [kN]	steel 5.8	5,0	8,6	10,9	19,8	21,1	32	51		
Partial factor	$\gamma_{Ms}^{(2)}$ [-]		1,25								
Characteristic resistance	$V_{Rk,s}^0$ [kN]	steel 8.8	6,8	8,6	10,9	19,8	27	32	51		
Partial factor	$\gamma_{Ms}^{(2)}$ [-]		1,25								
<b>Steel failure with lever arm</b>											
Characteristic resistance	$M_{Rk,s}^0$ [Nm]	A4-50	8	19	37	66	166	324			
Partial factor	$\gamma_{Ms}^{(2)}$ [-]		2,38								
Characteristic resistance	$M_{Rk,s}^0$ [Nm]	A4-70	11	26	52	92	232	454			
Partial factor	$\gamma_{Ms}^{(2)}$ [-]		1,56								
Characteristic resistance	$M_{Rk,s}^0$ [Nm]	A4-80	12	30	60	105	266	519			
Partial factor	$\gamma_{Ms}^{(2)}$ [-]		1,33								
Characteristic resistance	$M_{Rk,s}^0$ [Nm]	steel 4.6	6,1	15	30	52	133	259			
Partial factor	$\gamma_{Ms}^{(2)}$ [-]		1,67								
Characteristic resistance	$M_{Rk,s}^0$ [Nm]	steel 5.6	7,6	19	37	66	166	324			
Partial factor	$\gamma_{Ms}^{(2)}$ [-]		1,67								
Characteristic resistance	$M_{Rk,s}^0$ [Nm]	steel 5.8	7,6	19	37	66	166	324			
Partial factor	$\gamma_{Ms}^{(2)}$ [-]		1,25								
Characteristic resistance	$M_{Rk,s}^0$ [Nm]	steel 8.8	12	30	60	105	266	517			
Partial factor	$\gamma_{Ms}^{(2)}$ [-]		1,25								
<b>Concrete pryout failure</b>											
Factor for pryout failure	$k_8$ [-]		1,74	1,9	1,74	1,9	2,0				
<b>Concrete edge failure</b>											
Effective length of anchor	$l_f$ [mm]		30	40	30	40	50	65	80		
Effective diameter of anchor	$d_{nom}$ [mm]		8	10	12	15	16	20	25		

<sup>1)</sup> Use restricted to anchoring of structural components which are statically indeterminate

<sup>2)</sup> In absence of other national regulations

fischer drop-in anchor EA II

**Performances**

Characteristic resistance to shear loads under static and quasi-static action

**Annex C 2**

Appendix 10 / 11

**Table C3.1:** Displacements under tension and shear loads for EA II in galvanised steel

EA II										
		M6x30	M8x30	M8x40	M10x30	M10x40	M12x50	M12x50 D	M16x65	M20x80
Tension load in C20/25 to C50/60	N [kN]	4,0		6,1	4,0	6,1	8,5		12,6	17,2
Displacement	$\delta_{N_0}$ [mm]	0,1								
	$\delta_{N_\infty}$ [mm]	0,2								
Shear load in C20/25 to C50/60	V [kN]	3,9	4,9	6,2		11,3	15,2	18,5	29,4	
Displacement	$\delta_{V_0}$ [mm]	0,95	1,00	1,05		1,10		1,40	1,80	
	$\delta_{V_\infty}$ [mm]	1,40	1,50	1,60		1,70		2,10	2,70	

**Table C3.2:** Displacements under tension and shear loads for EA II in stainless steel

EA II R										
		M6x30	M8x30	M8x40	M10x30	M10x40	M12x50	M12x50 D	M16x65	M20x80
Tension load in C20/25 to C50/60	N [kN]	4,0		6,1	4,0	6,1	8,5		12,6	17,2
Displacement	$\delta_{N_0}$ [mm]	0,1								
	$\delta_{N_\infty}$ [mm]	0,2								
Shear load in C20/25 to C50/60	V [kN]	3,2	5,6	7,1		12,9	13,5	21,1	33,5	
Displacement	$\delta_{V_0}$ [mm]	0,95	1,00	1,05		1,10		1,40	1,80	
	$\delta_{V_\infty}$ [mm]	1,40	1,50	1,60		1,70		2,10	2,70	

fischer drop-in anchor EA II

**Performances**  
 Displacements
**Annex C 3**

Appendix 11 / 11