

## TELJESÍTMÉNYNYILATKOZAT

### DoP 0262

fischer-Zykon-paneldübel FZP II T (for Royal Mosa)

HU

- |  |   |              |                            |
|--|---|--------------|----------------------------|
| 1. <u>A terméktípus egyedi azonosító kódja:</u>  | <b>DoP 0262</b>   |              |                            |
| 2. <u>Felhasználás célja(i):</u>   | <b>Rögzítőelem a "Royal Mosa " kerámia lapokból készült homlokzati panelek hátsó rögzítéséhez az EN 14411:2016 szerint., ld. a Mellékletet, különösen ezt a mellékletet B1 - B11.</b> |              |                            |
| 3. <u>Gyártó:</u>  | <b>fischerwerke GmbH &amp; Co. KG, Klaus-Fischer-Str. 1, 72178 Waldachtal, Németország</b>  |              |                            |
| 4. <u>A meghatalmazott képviselő:</u>  | -   |              |                            |
| 5. <u>Az AVCP-rendszer(ek):</u>  | <b>2+</b>   |              |                            |
| 6. <u>Az európai értékelési dokumentum:</u>  | <b>EAD 330030-00-0601</b>   |              |                            |
| Európai műszaki értékelés:   | <b>ETA-11/0465; 2016-12-14</b>  |              |                            |
| A műszaki értékelést végző szerv:  | <b>DIBt- Deutsches Institut für Bautechnik</b>  |              |                            |
| Bejelentett szerv(ek):   | <b>2873 TU Darmstadt</b>  |              |                            |
| 7. <u>A nyilatkozatban szereplő teljesítmény(ek):</u>  |   |              |                            |
| <b>Mechanikus szilárdság és stabilitás (BWR 1)</b>   |   |              |                            |
| Kitöréshez-vagy kihúzóadási tönkremenetelhez tartozó karakterisztikus ellenállás értéke húzás hatására:                    |   | Melléklet C1 | $\alpha_{TR} = \text{NPD}$ |
| Kitöréshez-vagy kihúzóadási tönkremenetelhez tartozó karakterisztikus ellenállás értéke nyírás hatására:                   |   | Melléklet C1 |                            |
| Kitöréshez-vagy kihúzóadási tönkremenetelhez tartozó karakterisztikus ellenállás értéke egyidejű húzás és nyírás hatására: |   | Melléklet B4 |                            |
| Perem-és tengelytávolság:  |   | Melléklet C1 |                            |
| Tartósság:   |   | Melléklet A3 |                            |
| Acél tönkremenetelhez tartozó karakterisztikus ellenállás értéke húzás és nyírás hatására:                                 |   | NPD          |                            |
| <b>Biztonság tűz esetén (BWR 2)</b>  |   |              |                            |
| Tűzzel szembeni viselkedés:  |   | Osztály (A1) |                            |
| 8. <u>Megfelelő műszaki dokumentáció és/vagy egyedi műszaki dokumentáció:</u>  | -   |              |                            |

A fent azonosított termék teljesítménye megfelel a bejelentett teljesítmény(ek)nek. A 305/2011/EU rendeletnek megfelelően e teljesítménynyilatkozat kiadásáért kizárólag a fent meghatározott gyártó a felelős.

A gyártó nevében és részéről aláíró személy:

Dr.-Ing. Oliver Geibig, Üzleti egységek és Mérnökségért felelős vezérigazgató  
Tumlingen, 2021-01-11

Jürgen Grün, Vegyi és Minőségért felelős vezérigazgató

Ez a Teljesítmény nyilatkozat különböző nyelveken elkészült. Vitás értelmezés esetén az angol verzió az irányadó.

A melléklet a (nyelvsemleges formában megadott) törvényi előírásokon túl önkéntesen megadott, kiegészítő információkat is tartalmaz angolul.

## Specific Part

### 1 Technical description of the product

The fischer-Zykon-panel anchor FZP II T is a special anchor of size M 6 which consists of a cone bolt with external thread, made of stainless steel, an expansion part made of stainless steel, a shim washer made of polyamide and, if need to be, a hexagon nut made of stainless steel or aluminium. The anchor is put into an undercut drill hole in the façade panels and is placed form-fit by driving-in the shim washer or by applying a torque moment to the hexagon nut.

The product description is given in Annex A.

### 2 Specification of the intended use in accordance with the applicable European Assessment Document

The performances given in Section 3 are only valid if the anchor is used in compliance with the specifications and conditions given in Annex B.

The verifications and assessment methods on which this European Technical Assessment is based lead to the assumption of a working life of the anchors of at least 50 years. The indications given on the working life cannot be interpreted as a guarantee given by the producer, but are to be regarded only as a means for choosing the right products in relation to the expected economically reasonable working life of the works.

### 3 Performance of the product and references to the methods used for its assessment

#### 3.1 Mechanical resistance and stability (BWR 1)

Essential characteristic	Performance
Characteristic resistance for tension and shear loads	See Annex C 1
Anchor distances and dimensions of members	See Annex C 1

#### 3.2 Safety in case of fire (BWR 2)

Essential characteristic	Performance
Reaction to fire	Class A 1
Resistance to fire	No performance assessed

### 4 Assessment and verification of constancy of performance (AVCP) system applied, with reference to its legal base

In accordance with EAD No. 330030-00-0601 the applicable European legal act is: [97/161/EG].

The system to be applied is: 2+

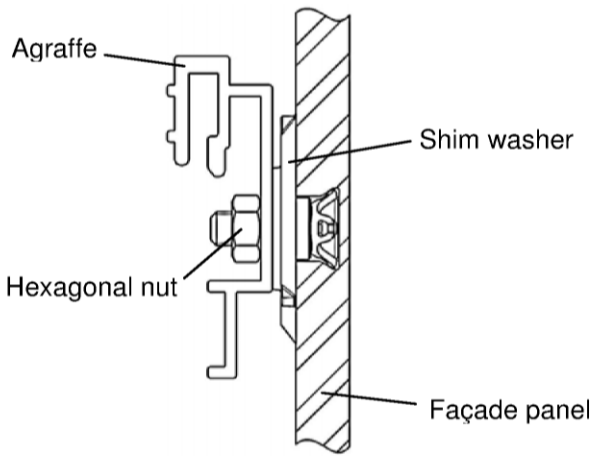

without hexagonal nut (SW19)

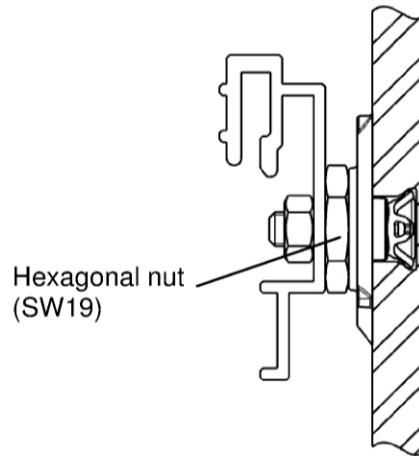

with hexagonal nut (SW19)

**Example of a subframe**

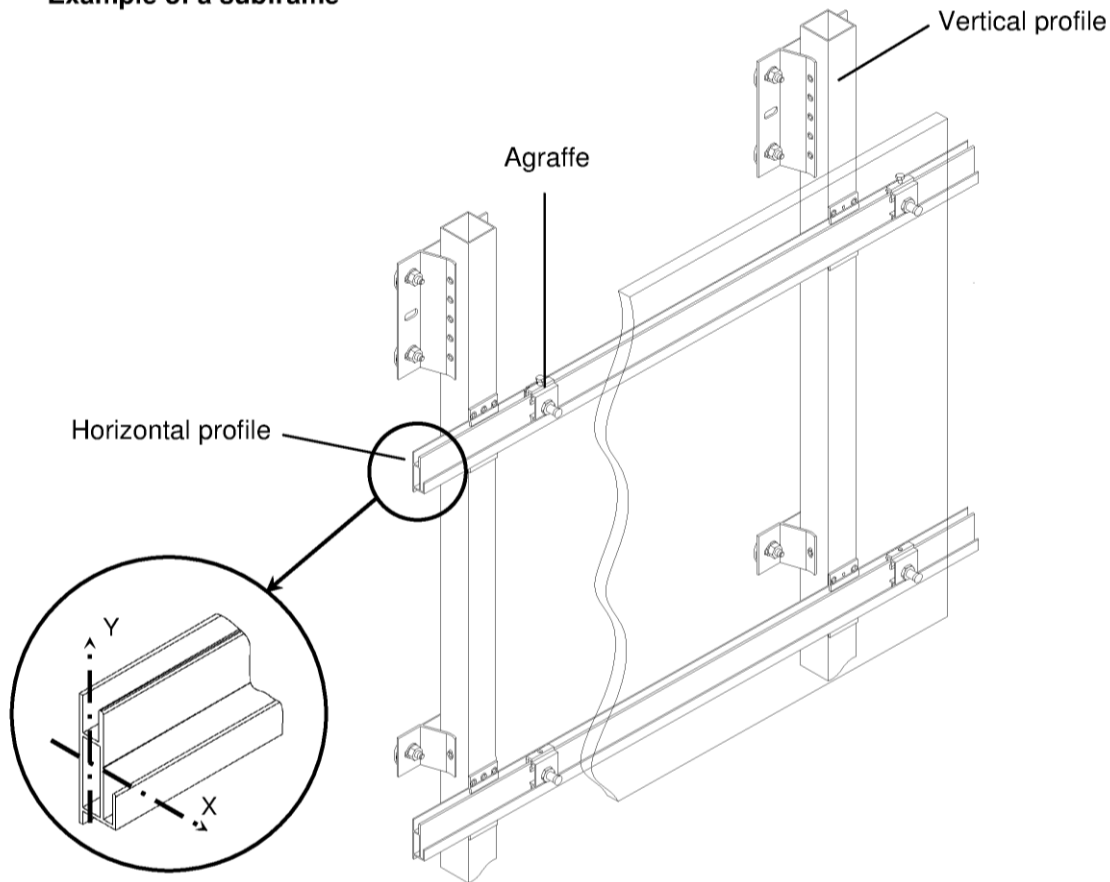

fischer Zykon panel anchor FZP II T for "Royal Mosa stoneware"

**Product description**  
Installed fastener and fixing example

Annex A 1  
Appendix 2 / 16

Type of anchor

Anchor with external thread M6

without hexagonal nut

with hexagonal nut

FZP II T

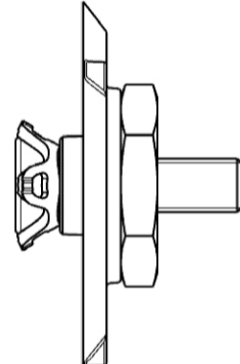
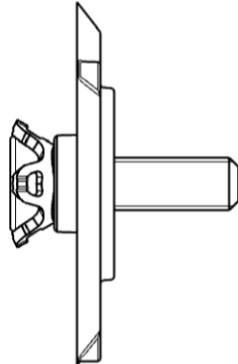

Type of mounting / System of designation

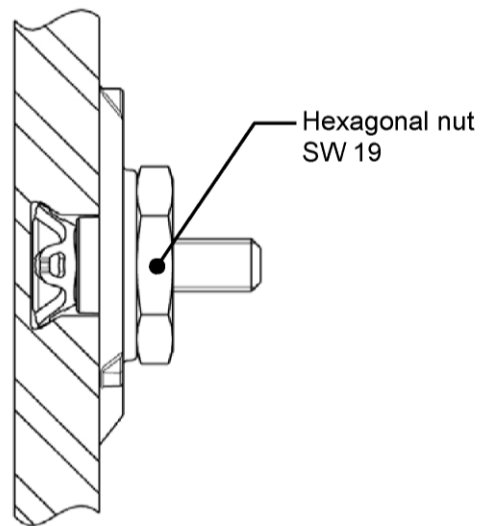
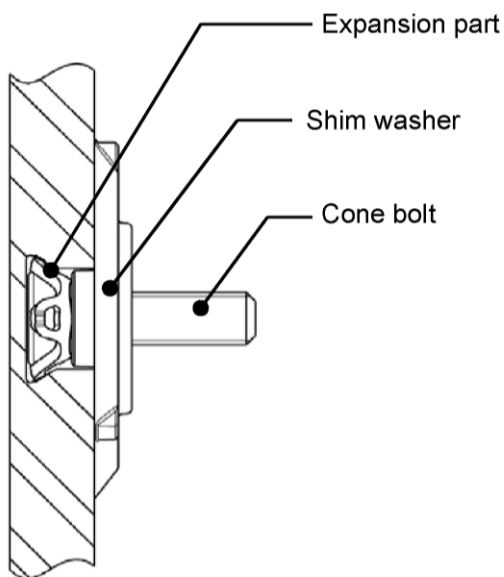

Optional with hexagonal nut

Example:

FZP II 11x6 M6 / T / 9 Al

Hexagonal nut material

Bolt projection length  $b$

Thin materials

Thread diameter

Drill hole depth  $h_1$  (with FZP II T  $h_1 = h_s =$  embedment depth)

Cylindrical drill hole  $\varnothing$

Fischer Zykon Panel anchor II

(Drill hole geometry: cylindrical conical)

fischer Zykon panel anchor FZP II T for "Royal Mosa stoneware"

**Product description**  
Product and built-in state

Annex A 2  
Appendix 3 / 16

## Anchor parts and materials

### Cone bolt External thread M6

Option:  
Anti rotation lock  
(Nose)



Drive optional, e.g.: slot,  
hexagon socket,  
external hexagon,  
spanner flats

### Expansion part

For cone bolts with external thread M6



### Shim washer

For cone bolts with external thread M6

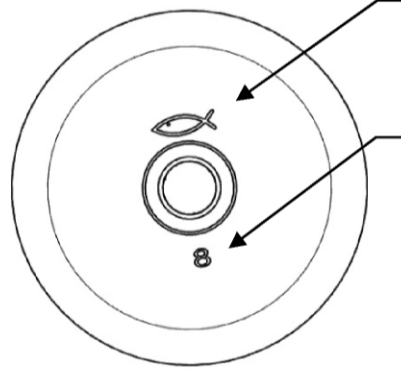
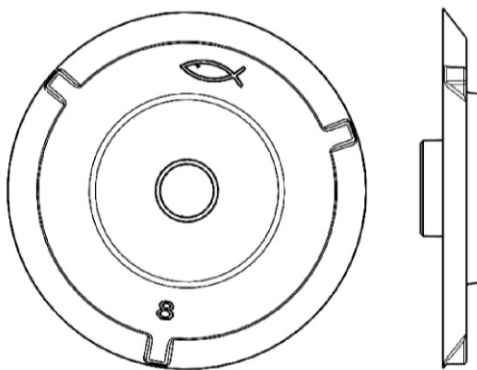

Identifying mark of the  
producer

Anchorage depth

### Hexagonal nut

For cone bolts with external thread M6

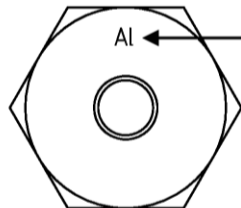

Marking: Al = Aluminium  
Optional: A4 = stainless steel

**Table A1:** Material of anchor parts

Anchor parts	Material
Cone bolt	Stainless steel, EN 10088 :2014
Expansion part	Stainless steel, EN 10088 :2014
Shim washer	Polyamide 6.6
Hexagonal nut	Aluminium, EN 755 :2016 optional: Stainless steel, EN 10088 :2014

fischer Zykon panel anchor FZP II T for "Royal Mosa stoneware"

**Product description**  
Parts of anchor and material

Annex A 3  
Appendix 4 / 16

## Specifications of intended use

### Anchorage subject to:

- Static and quasi-static loads.

### Base materials:

- the "Royal Mosa" porcelain stoneware façade panels shall correspond to the group BI<sub>a</sub> according to EN 14411:2016 and to the specifications given in Annex B 8.

### Use conditions (Environmental conditions):

- Structures subject to dry internal conditions.
- Structures subject to external atmospheric exposure (including industrial and marine environment) and to permanently damp internal condition, if no particular aggressive conditions exist.

Note: Particular aggressive conditions are e.g. permanent, alternating immersion in seawater or the splash zone of seawater, chloride atmosphere of indoor swimming pools or atmosphere with extreme chemical pollution (e.g. in desulphurization plants or road tunnels where de-icing materials are used).

### Design:

- The design of the façade panels and their fixing is carried out according to the conditions given in Annex B 2 to Annex B 9 .

### Installation:

- The drillings are done at the factory or on site under workshop conditions; when making the drillings on site the execution is supervised by the responsible project supervisor or a skilled representative of the project supervisor.
- Making of the undercut drilling is done with the drill bit according to Annex B 9 and a special drilling device in accordance with the information deposited with Deutsches Institut für Bautechnik.
- The drilling residues are removed from the drill hole
- In case of aborted hole: new drilling at a minimum distance away of twice the depth of the aborted hole.
- The geometry of the drill hole is checked on 1 % of all drillings. In addition, every 500<sup>th</sup> drill hole and drill change the diameter of the undercut must be checked with the internal quicktest. The following dimensions shall be checked and documented according to manufacturer's information and testing instructions by means of a measuring device according to Annex B 10:
  - Diameter of the cylindrical drill hole
  - Diameter of the undercut
  - Remaining wall thickness (drill hole depth and panel thickness respectively)

If the tolerances given in Annex B 9 are exceeded, the geometry of the drill hole shall be checked on 25 % of the drillings performed. No further drill hole may exceed the tolerances otherwise all the drill holes shall be controlled. Drilling holes falling below or exceeding the tolerances shall be rejected.

Note: Checking the geometry of the drill hole on 1 % of all drillings means that on one of the 25 panels (this corresponds to 100 drillings) one drilling shall be checked. If the tolerances given in Annex B 9 are exceeded the extent of the control shall be increase to 25 % of the drillings, i.e. one drilling each shall be checked on all the 25 panels.

- During transport and storage on site the façade panels are protected from damages; the façade panels are not to be hung up jerkily (if need be lifters shall be used for hanging up the façade panels); façade panels and reveal panels respectively with incipient cracks are not be installed.
- The anchors are installed in a deformation controlled manner. For this purpose suitable installation tools per Annex B 10 shall be used.  
The anchor is set correctly if, in the state, the spacer is flush with the back of the panel and the bolt projection "b" as per Annex A 2 or Annex B 11 Figure 5.1 is observed.
- The façade are installed by skilled specialists and the laying instructions of the manufacturer shall be paid attention to.
- The façade panels are arranged in a "reclined" or "upright" position, they also may be fixed at façade soffits.

fischer Zykon panel anchor FZP II T for "Royal Mosa stoneware"

**Intended use**  
Specifications

Annex B 1  
Appendix 5 / 16

## Design method

### General

The design values of the actions shall be calculated on basis of EN 1990 in consideration of the existing loads. The combinations of actions shall be equal to EN 1990. The actions shall be specified according to EN 1991-1-1 to EN 1991-1-7. Corresponding national regulations shall be taken into consideration. The unfavourable combination is decisive. Where necessary for the design of the anchor and the façade panel several combinations shall be analysed separately.

The typical fundamental combination for façade panels considers actions from dead load  $F_{Ek,G}$  (permanent action) and wind  $F_{Ek,w}$  (leading variable action).

According to EN 1990 the following fundamental combination depending on the load direction results for a vertical façade panel:

Fundamental combination for loads parallel to the panel:  $F_{Ed||} = F_{Ek,G} \cdot \gamma_G$

Fundamental combination for loads perpendicular to the panel:  $F_{Ed\perp} = F_{Ek,w} \cdot \gamma_Q$

with  $\gamma_G = 1,35$ ;  $\gamma_Q = 1,50$

For hanging panels (over head mounting) or reveals respectively the load direction shall be taken into consideration and the combinations of actions shall be based on EN 1990.

The calculation shall be carried out in a linear elastic manner. The stiffness of the substructure shall be considered for the respective case of application. The design value of the actions shall be compared with the design values of the resistance.

- Each façade panel is fixed with at least four anchors in a rectangular arrangement via single agraffes on the substructure (for small panels or small fitted pieces, differential or fill- in pieces the number and position of the anchors shall be chosen constructively).
- The substructure is constructed such that the façade panels are fixed according to Annex B 6 technically strain-free via skids (loose bearings) and one fixed point (fixed bearing) - the fixed point may be placed at the panel edge or in the panel field - and that there are no additional loads acting on the panels and their fixings due to excentric load application / load transfer (symmetrical bearing of the panels).
- Two fixing points of the façade panel are designed such that they are able to carry the dead load of the façade panel.
- When using agraffes on horizontal load-bearing profiles the fixing points of a façade panel situated horizontally at the same height are fastened in each case to the same load-bearing profile.
- Joint construction between the façade panels is done by a joint filler or permanently elastic filler or are kept open; it is ensured that additional stresses (e.g. by temperature) do not lead to important additional loadings.
- Verifiable calculation notes and drawings shall be prepared taking account of the loads to be anchored, the nature and strength of the base materials and the dimensions of the anchorage members as well as of the relevant tolerances. The position of the anchor is indicated on the design drawings.
- The façade panels, their fixings as well as the substructure including its connection to wall brackets and their connection to the construction works are designed for the respective case of application under the responsibility of an engineer skilled in the field of façade construction.
- When using horizontal load-bearing profiles the following shall be verified:
  - The agraffes do not prop on the façade panel due to torsion of the horizontal load-bearing profile and twisting of the façade panel.
  - The total of the angle  $\alpha$  results from torsion of the horizontal load-bearing profile and twisting of the façade panel at the fixing point does not exceed the value  $\alpha = 2^\circ$ .
- Design of the anchor and the façade panels is carried out according to the design method according to Annex B 3 to Annex B 5.
- The characteristic wind loads for selective panel sizes and bearing conditions given in Annex B 5, Table B1 apply only, if the substructure (horizontal and vertical profiles) and their fixings are arranged symmetrically.

fischer Zykon panel anchor FZP II T for "Royal Mosa stoneware"

**Intended use**  
Design method

Annex B 2  
Appendix 6 / 16

## Guideline for structural calculation by means of FE - method

For structural calculation by means of the Finite-Element-Method the façade panels are to be idealized with their effective dimensions (size and thickness) as panel elements; the system chosen shall have the capacity to sufficiently precise represent the tension and the deformation state as well as the support reactions of the façade panels. The mesh size at fixing range shall not exceed 10 mm.

The modelling of the façade panel is to be calibrated on the basis of the following points:

- modelling a panel section of 580 mm x 300 mm with a panel thickness of 12 mm
- support at the short sides with rotatable restraint
- loading at centre with a single load of 1,17 kN
- determination of a factor  $f_{cal.FE} = 58,8 / \sigma_{FE}$
- the determined bending stresses shall be multiplied with factor  $f_{cal.FE}$  ( $\sigma_{Ek} = \sigma_{FE} \cdot f_{cal.FE}$ ); the factor  $f_{cal.FE}$  shall only be considered for stresses due to support moments.

$\sigma_{FE}$  = maximum of main tensile stress [N/mm<sup>2</sup>]

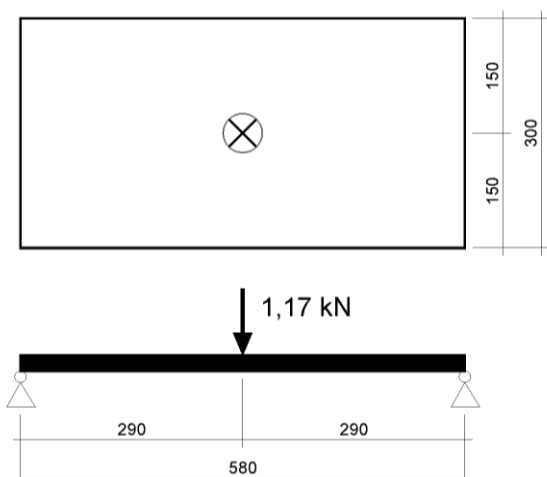

fischer Zykon panel anchor FZP II T for "Royal Mosa stoneware"

**Intended use**  
Design

Annex B 3  
Appendix 7 / 16



### Verification of the anchor loads

For the determined anchor forces it shall be verified that the equation (1) and (2) are fulfilled. For combined tension and shear forces additional equation (3) has to be fulfilled.

$$\text{Tension / compression load: } \frac{N_{Ed}}{N_{Rd}} \leq 1,0 \quad (1)$$

$$\text{Shear load: } \frac{V_{Ed}}{V_{Rd}} \leq 1,0 \quad (2)$$

$$\text{interaction oblique tension: } \frac{N_{Ed}}{N_{Rd}} + \frac{V_{Ed}}{V_{Rd}} \leq 1,0 \quad (3)$$

with:

$N_{Ed}$  = design value of existing anchor tension load

$V_{Ed}$  = design value of existing anchor shear load

$N_{Rd}$  = design value of anchor load-bearing capacity for tension load:  $N_{Rd} = \frac{N_{Rk}}{\gamma_M}$

$V_{Rd}$  = design value of anchor load-bearing capacity for shear load:  $V_{Rd} = \frac{V_{Rk}}{\gamma_M}$

$N_{Rk}$  = characteristic resistance tension (Annex C 1)

$V_{Rk}$  = characteristic resistance shear (Annex C 1)

$\gamma_M$  = partial safety factor (Annex C 1)

### Verification of the bending stresses

For the determined bending stresses it shall be verified, that the following equation is met:

$$\sigma_{Ed} \leq \sigma_{Rd} \quad (4)$$

with:

$\sigma_{Ed}$  = design value of existing bending stress in the façade panel

$\sigma_{Rd}$  = design value of bending strength:  $\sigma_{Rd} = \frac{\sigma_{Rk}}{\gamma_M}$

$\sigma_{Rk}$  = characteristic design value of bending strength (Annex 6)

### Characteristic wind loads for selective panel sizes and bearing conditions

In Annex B 5 Table B1 several panel systems are listed as a function of the slab thickness, the anchorage depth, the edge distance, the panel size, the number of agraffes and the kind of support.

The prove of structural stability is fulfilled if the characteristic wind load  $w_{Ek}$  does not exceed the values of  $w_{Ek,Tab}$  in Table B1. In addition, precise engineering calculations can also be carried out.

$$w_{Ek} \leq w_{Ek,Tab}$$

with:

$w_{Ek}$  = characteristic wind load

$w_{Ek,Tab}$  = Table value of characteristic wind loads

fischer Zykon panel anchor FZP II T for "Royal Mosa stoneware"

**Intended use**  
Design method

Annex B 4  
Appendix 8 / 16

**Table B1: Characteristic wind loads**

System	$d_0$ ≧ [mm]	$h_s$ = [mm]	$a_{rx,1}$ $a_{ry,2}$ [mm]	$a_{ry,1}$ $a_{rx,2}$ [mm]	Panel length/width [mm]	Agraffes	Kind of supports according Annex B 7	Strength class		
								A	B	C
								Characteristic wind load		
								$W_{Ek,Tab}$ [kN/m <sup>2</sup> ]	$W_{Ek,Tab}$ [kN/m <sup>2</sup> ]	$W_{Ek,Tab}$ [kN/m <sup>2</sup> ]
1	10	6	50-150	50-150	600x600	4	Figure 5	3,5	3,9	4,4
	12	8						5,0	5,7	6,4
	13	9						5,8	6,7	7,5
2	10	6	50-150	50-200	600x900	4	Figure 5	2,1	2,4	2,7
	12	8						3,1	3,5	3,9
	13	9						3,6	4,1	4,6
3	10	6	50-150	100-250	600x1200	4	Figure 5	1,5	1,7	1,9
	12	8						2,1	2,4	2,8
	13	9						2,5	2,9	3,2
4	10	6	50-200	50-200	750x750	4	Figure 5	1,9	2,2	2,5
	12	8						2,8	3,2	3,6
	13	9						3,3	3,7	4,2
5	10	6	100-200	100-200	900x900	4	Figure 5	1,6	1,8	2,0
	12	8						2,3	2,6	2,9
	13	9						2,7	3,0	3,4
6	10	6	100-225	150-250	900x1200	4	Figure 5	1,1	1,3	1,4
	12	8						1,6	1,8	2,1
	13	9						1,9	2,1	2,4
7	10	6	100-200	100-200	1000x1000	4	Figure 5	1,3	1,5	1,6
	12	8						1,8	2,1	2,4
	13	9						2,2	2,5	2,8
8	10	6	100-250	100-250	1200x1200	4	Figure 5	0,8	0,9	1,0
	12	8						1,2	1,3	1,5
	13	9						1,4	1,6	1,8
9	10	6	50-100	125-150	600x1200	6 <sup>1)</sup>	Figure 6 and 7	1,8	2,0	2,3
	12	8						2,6	2,9	3,3
	13	9						3,0	3,4	3,9
10	10	6	150-200	125-175	900x1200	6 <sup>1)</sup>	Figure 6 and 7	1,2	1,4	1,6
	12	8						1,8	2,0	2,3
	13	9						2,1	2,4	2,7
11	10	6	150-200	100-150	1000x1000	6 <sup>1)</sup>	Figure 6 and 7	1,4	1,6	1,8
	12	8						2,1	2,3	2,6
	13	9						2,4	2,7	3,1
12	10	6	200-250	150-200	1200x1200	6 <sup>1)</sup>	Figure 6 and 7	1,0	1,2	1,3
	12	8						1,5	1,7	1,9
	13	9						1,7	2,0	2,3

<sup>1)</sup> - The subframe has to be symmetrical.

For further constructional requirements refer to Annex B 6, Figure 1-4.

- The moment of inertia of profiles, supporting three fixing points of a panel, must be minimum  
 $I_y [cm^4] = 26,1 \cdot L_i [m] - 19,4$ .

valid for:  $0,75 \leq L_i \leq 1,4$

$L_i$  : equivalent support width (Annex B 6, Figure 4)

$I_y$  : The moment of inertia of profiles, in direction parallel to the façade panel layer.  
(resistance normal to the façade panel layer – see Annex A 1)

The modules of elasticity of the profiles must be  $E \geq 70000 \text{ N/mm}^2$ .

fischer Zykon panel anchor FZP II T for “Royal Mosa stoneware“

**Intended use**  
Design

Annex B 5  
Appendix 9 / 16

# Maximum support spacing and location of the subframe fixings

Caption:

- ① = Panel
- ② = Fixing point
- ③ = Profile
- ④ = Support location

Figure 1

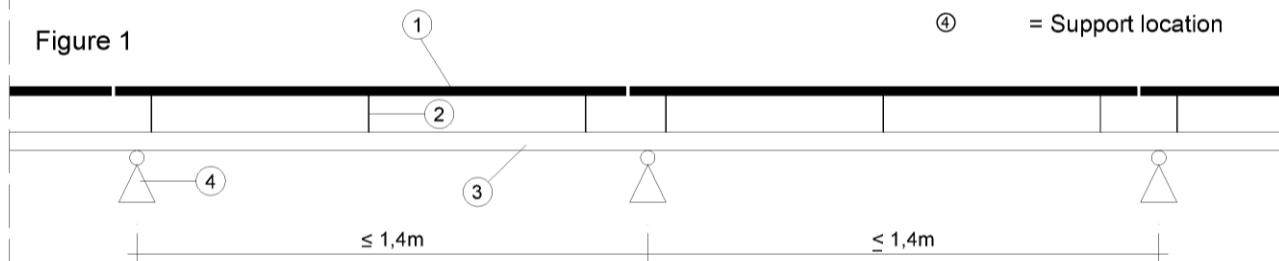

- Profiles, supporting three fixing points of a panel, have a maximum spacing of the supports of 1,4 m (see Figure 1)

Figure 2

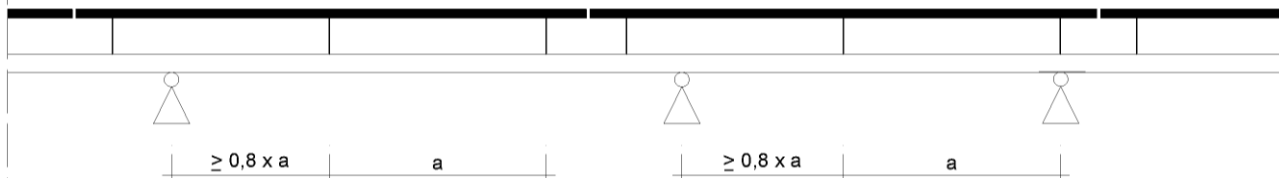
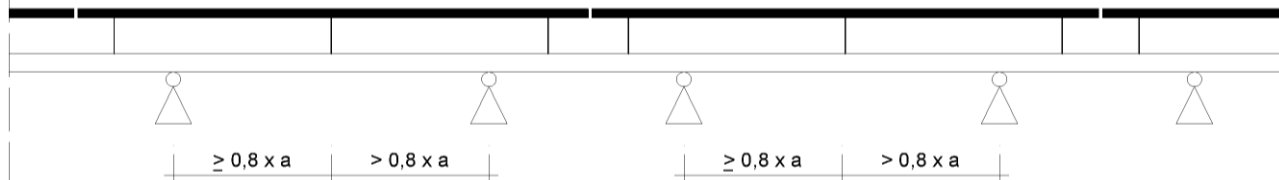
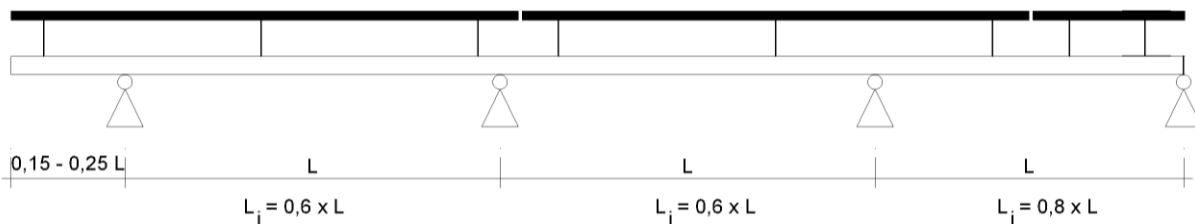

Figure 3



- In profiles, supporting three fixing points of a panel, the central fixing points must have a minimum distance of  $0,8 \bullet a$  to the supports. Whereby "a" is the spacing of the fixing points of the panel

Figure 4: Equivalent support spacing



fischer Zykon panel anchor FZP II T for "Royal Mosa stoneware"

**Intended use**  
Support

Annex B 6  
Appendix 10 / 16

# Supports – Definition of edge distances and spacing

Figure 5

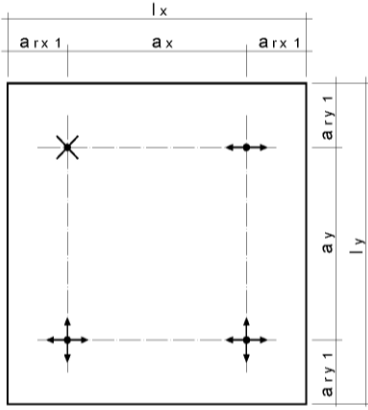

**Caption:**



- $a_{rx}, a_{ry}$  = Edge distance – anchor distance to the panel edge
- $a_x, a_y$  = Spacing – Distance between the anchors
- $l_x$  = Length of the panel in horizontal direction
- $l_y$  = Length of the panel in vertical direction
-  = Fixed bearing (fixed support)
-  = Horizontal slide bearing (slide support)
-  = Horizontal and vertical slide bearing (slide support)

Figure 6

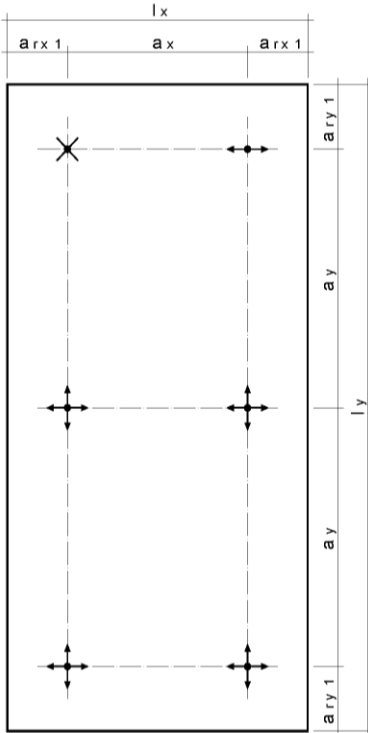
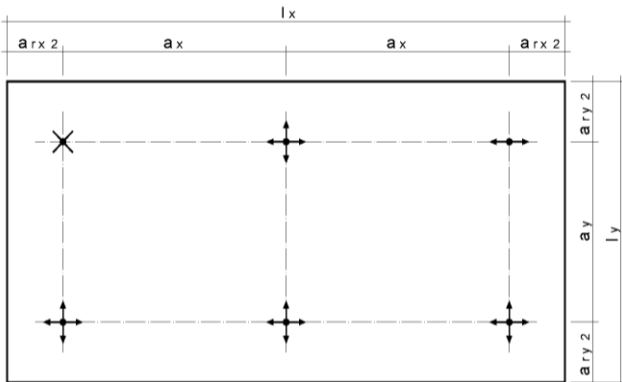

Figure 7



fischer Zykon panel anchor FZP II T for “Royal Mosa stoneware“

**Intended use**  
Supports – Definition of edge distances and spacing

Annex B 7  
Appendix 11 / 16

## Requirements of "Royal Mosa porcelain stoneware"- façade panels

### Classification test (Initial type test)

The „Royal Mosa porcelain stoneware"- façade panels “ shall be classified according to EN 14411:2016 "Ceramic tiles". The „Royal Mosa porcelain stoneware"- façade panels “ shall be classified to the group BI<sub>a</sub> according to EN 14411:2016.

The following values shall be checked on at least 10 samples:

- bending strength - determined according to EN ISO 10545-4:2014-11 with the "visible face" on top; deviating from EN ISO 10 545-4:2014-11 the dimension of the test specimen is  $l/b = 400/200$  mm and the support span is  $l_s = 300$  mm
- axial tension load – determined on test specimens with dimensions of  $l/b = 200/200$  mm, an edge distance of 100 mm and a support diameter of  $\varnothing = 70$  mm (Panel thickness and anchorage depth according to building project)
- shear load – determined on test specimens with dimensions of  $l/b = 400/200$  mm and an edge distance of 100 mm (Panel thickness and anchorage depth according to building project)

### Acceptance Test (Verification of constancy of performance)

For each construction project the following values shall be checked on at least 10 samples independent of the scope of delivery:

- axial tension load – determined on test specimens with dimensions of  $l/b = 200/200$  mm, an edge distance of 100 mm and a support diameter of  $\varnothing = 70$  mm (Panel thickness and anchorage depth according to building project)

From the test results (Classification and Acceptance tests) the 5%-Fractile (confidence level of 75%, unknown standard deviation and lognormal distribution) shall be determined.

With the determined values of the 5%-Fractile the façade panels are to be classified according to the respective property class corresponding to Table B2.

**Table B2: characteristic values of façade panels –mechanical properties**

strength class of façade panels			A	B	C
Bending strength ("visible face" on top)	$\sigma_{u5\%} \geq$	[N/mm <sup>2</sup> ]	35	40	45
pull-out load tension load	$h_s = 6,0$ mm	$N_{u5\%} \geq$	[kN]	1,8	
	$h_s = 8,0$ mm			3,1	
	$h_s = 9,0$ mm			3,5	
pull-out load shear load	$h_s = 6,0$ mm	$V_{u5\%} \geq$	[kN]	3,0	
	$h_s = 8,0$ mm			3,6	
	$h_s = 9,0$ mm			3,8	

fischer Zykon panel anchor FZP II T for "Royal Mosa stoneware"

**Intended use**  
Requirements of façade panels

Annex B 8

Appendix 12 / 16

### Drill bit

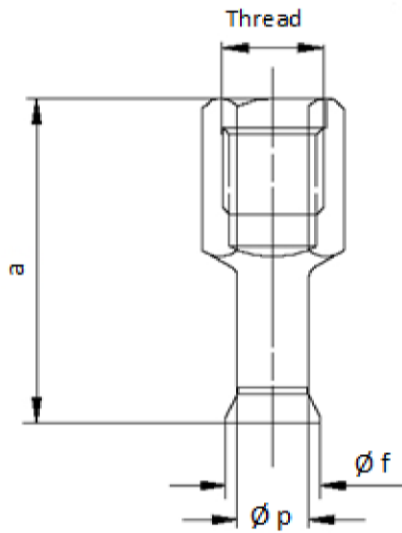

### Dimension of drill hole

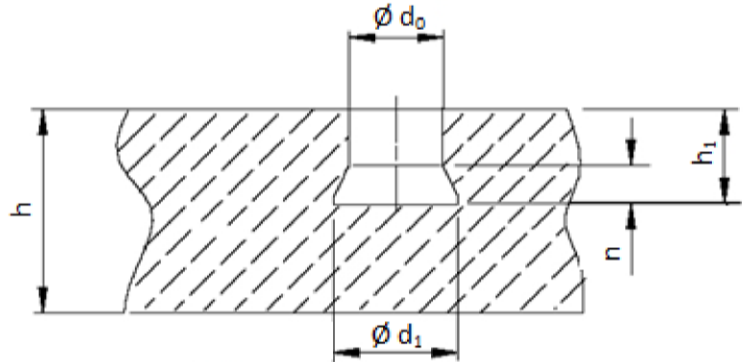

**Table B3: Drill bit assignment and dimensions of drill bit and drill hole [mm]**

Drill bit						
Typ	Thread	a	Ø p	Ø f		
FZPB 11 (9) <sup>2)</sup>	M14	45	8,5 (6,5) <sup>2)</sup>	11 (9) <sup>2)</sup>		
Drill Hole		Ø d <sub>0</sub> <sup>1)</sup>	Ø d <sub>1</sub> <sup>1)</sup>	FZP II T	n	h <sub>1</sub>
		11 + 0,4 - 0,2	13,5 ± 0,3	M6	≈ 4	6; 8; 9; + 0,4 - 0,1

<sup>1)</sup> Measurements can be proved by diameter or volume gauge (Annex B 10)

<sup>2)</sup> Drill bit for different drill methods respectively drilling machine

**Table B4: Installation parameters**

Achor type		FZP II T 11x6	FZP II T 11x8	FZP II T 11x9
Anchorage depth	$h_s =$ [mm]	6	8	9
Panel thickness	$h \geq$ [mm]	10	12	13

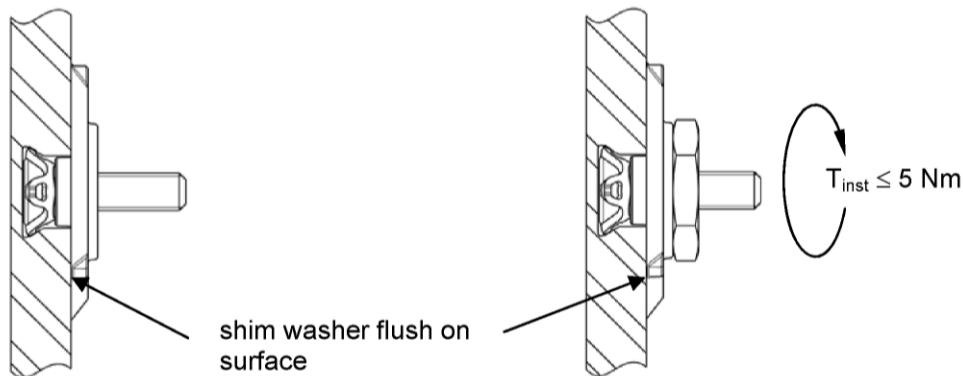

fischer Zykon panel anchor FZP II T for "Royal Mosa stoneware"

**Intended use**  
Drill bit, geometry of the drill hole and installation parameters

Annex B 9  
Appendix 13 / 16

**Setting tools**

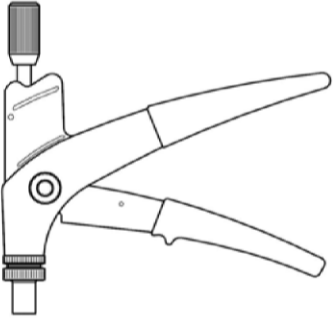

Manual setting tool SGT

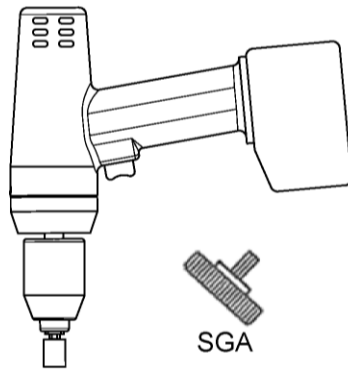

Cordless screwdriver with SW6 socket or setting tool SGA

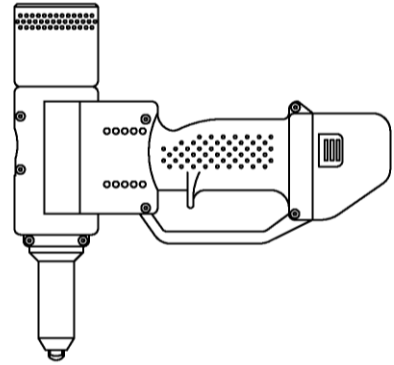

Battery driven setting tool SGB

**Testing equipment for checking the undercut  $\varnothing d_1$**

**Go / no Go gauge for checking cylindrical drill hole diameter  $\varnothing d_0$**

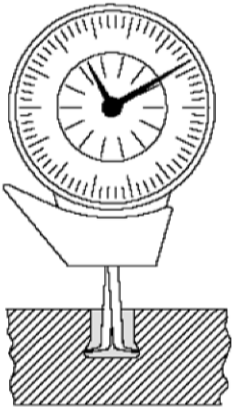

Internal quicktest

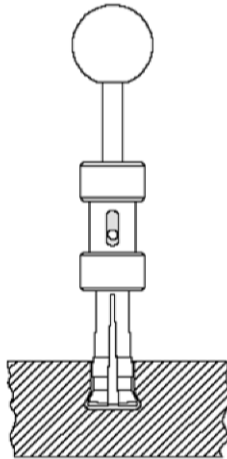

Undercut minimum volume gauge (HVL)

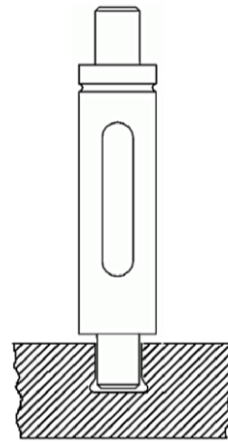

Diameter gauge (DPL)

**Depth measurement  $h_1$**

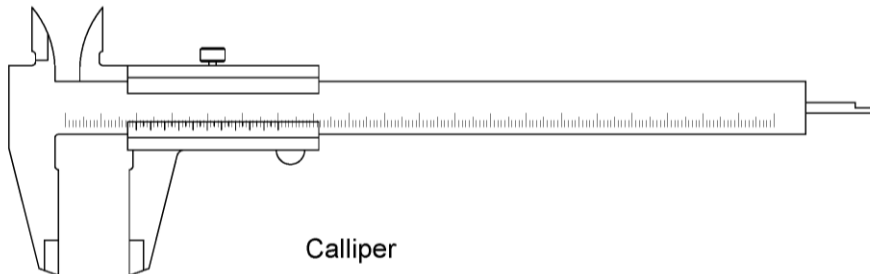

Calliper

fischer Zykon panel anchor FZP II T for "Royal Mosa stoneware"

**Intended use**  
Setting devices and testing equipment

Annex B 10

Appendix 14 / 16

# Installation instructions

1.)



2.)

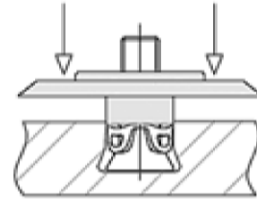

3.)

Example: Set with SGA

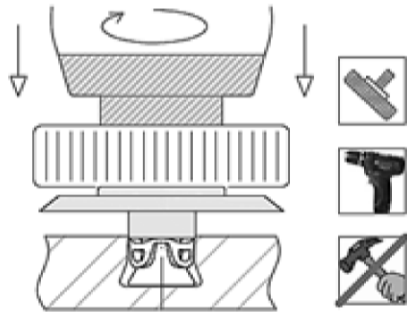

4.)

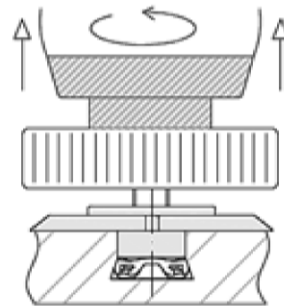

5.1)

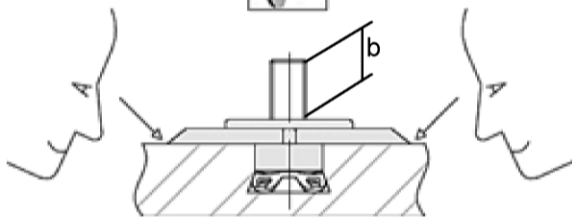

5.2)

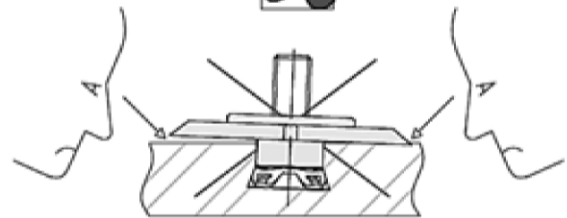

fischer Zykon panel anchor FZP II T for "Royal Mosa stoneware"

**Intended use**  
Installation instructions

Annex B 11  
Appendix 15 / 16



## Characteristic values of anchors and panels

**Table C1:** Characteristic values of anchors and panels

Panel values	Nominal panel thickness	$h \geq$	[mm]	10 ; 12 und 13		
	Maximum size of panel	$A =$	[m <sup>2</sup> ]	1,5		
	Maximum side length	$L =$	[m]	1,5		
	Minimum number of anchors in rectangular arrangement <sup>1)</sup>		[St]	4		
	Characteristic bending strength	$\sigma_{RK} =$	Class	A	B	C
			[N/mm <sup>2</sup> ]	$\geq 35$	$\geq 40$	$\geq 45$
	Elastic modulus	$E =$	[N/mm <sup>2</sup> ]	30.000		
	Poisson ratio	$\nu =$	[-]	0,2		
	Density	$\gamma =$	[kN/m <sup>3</sup> ]	25		
Partial safety factor <sup>2)</sup>	$\gamma_M =$	[-]	1,8			

Anchor values FZP II T	Bending strength class			A ; B and C		
	Nominal panel thickness	$d \geq$	[mm]	10	12	13
	Anchorage depth	$h_s =$	[mm]	6	8	9
	Characteristic tension load <sup>3)</sup>	$N_{RK} =$	[kN]	1,8	3,1	3,5
	Characteristic shear load <sup>3)</sup>	$V_{RK} =$	[kN]	3,0	3,6	3,8
	Edge distance <sup>4)</sup>	$a_r \geq$	[mm]	50		
	Spacing <sup>4)</sup>	$a \geq$	[mm]	100		
	Partial safety factor <sup>2)</sup>	$\gamma_M =$	[-]	1,8		

1) For panels smaller than 0,3 m<sup>2</sup> the number of anchors might be reduced to 3, due to the low level of loading.

2) In absence of other national regulations.

3) For interaction of tension and shear load Annex B 4 equation 3 is decisive.

4) For small fitted pieces, differential or fill-in pieces the minimum edge distance or spacing shall be chosen constructively.

fischer Zykon panel anchor FZP II T for "Royal Mosa stoneware"

**Performances**  
Characteristic values of anchors and panels

Annex C 1

Appendix 16 / 16