

TELJESÍTMÉNYNYILATKOZAT

DoP 0239

fischer injektált FIS V Zero rendszerhez (Injektált fém rögzítőelem falazatba történő alkalmazáshoz)

HU

- A terméktípus egyedi azonosító kódja: **DoP 0239**
- Felhasználás célja(i): **Falazatokba utólag beszerelhető rögzítés, ld. a Mellékletet, különösen ezt a mellékletet B1 - B14.**
- Gyártó: **fischerwerke GmbH & Co. KG, Otto-Hahn-Straße 15, 79211 Denzlingen, Németország**
- A meghatalmazott képviselő: **-**
- Az AVCP-rendszer(ek): **1**
- Az európai értékelési dokumentum: **EAD 330076-01-0604, Edition 05/ 2021**
Európai műszaki értékelés: **ETA-21/0267; 2021-08-27**
A műszaki értékelést végző szerv: **DIBt- Deutsches Institut für Bautechnik**
Bejelentett szerv(ek): **2873 TU Darmstadt**

7. A nyilatkozatban szereplő teljesítmény(ek):

Mechanikus szilárdság és stabilitás (BWR 1)

Karakterisztikus ellenállás értéke egy önálló dübel acél tönkremenetelével szemben húzóterhelés hatására: ld. a Mellékletet, különösen ezt a mellékletet C1, C3

Karakterisztikus ellenállás értéke egy önálló dübel acél tönkremenetelével szemben erőkarrel illetve erőkar nélküli nyíróterhelés hatására: ld. a Mellékletet, különösen ezt a mellékletet C2, C3

Karakterisztikus ellenállás értéke egy önálló dübel kihúzódással vagy téglá kitérésével szemben húzóterhelés hatására, Csökkentő tényező: ld. a Mellékletet, különösen ezt a mellékletet C5, C7, C10, C13, C15, C16

Karakterisztikus ellenállás értéke egy önálló dübel helyi téglá tönkremenetellel- vagy téglá kitérésével szemben nyíróterhelés hatására: ld. a Mellékletet, különösen ezt a mellékletet C5, C7, C11, C13, C15

Karakterisztikus ellenállás értéke egy dübelcsoport téglá kitérésével szemben húzóterhelés hatására: ld. a Mellékletet, különösen ezt a mellékletet B13, B14, C4, C6, C8, C9, C12, C14

Karakterisztikus ellenállás értéke egy dübelcsoport helyi téglá tönkremenetellel-vagy kitérésével szemben nyíróterhelés hatására: ld. a Mellékletet, különösen ezt a mellékletet B13, B14, C4, C6, C8, C9, C12, C14

Peremtávolságok, tengelytávolság, rögzítési alap vastagság: ld. a Mellékletet, különösen ezt a mellékletet B2, B13, C4, C6, C8, C9, C12, C14

Elmozdulások húzás és nyírás hatására: ld. a Mellékletet, különösen ezt a mellékletet C17

Maximális meghúzási nyomatok: ld. a Mellékletet, különösen ezt a mellékletet C4, C6, C8, C9, C12, C14

Tűzvédelem (BWR 2)

Viselkedése tűz esetén: Osztály (A1)

Ellenállás értéke tűznek kitett húzás és nyírás hatására erőkarrel és erőkar nélküli esetben, minimális perem-és tengelytávolságok értékei: NPD

Higiénia, egészség- és környezetvédelem (BWR 3)

Veszélyes anyagok tartalma, kibocsátása és / vagy kibocsátása: NPD

8. Megfelelő műszaki dokumentáció és/vagy egyedi műszaki dokumentáció: **-**

A fent azonosított termék teljesítménye megfelel a bejelentett teljesítmény(ek)nek. A 305/2011/EU rendeletnek megfelelően e teljesítménynyilatkozat kiadásáért kizárólag a fent meghatározott gyártó a felelős.

A gyártó nevében és részéről aláíró személy:



Dr.-Ing. Oliver Geibig, Üzleti egységek és Mérnökségért felelős vezérigazgató
Tumlingen, 2021-09-06

Jürgen Grün, Vegyi és Minőségért felelős vezérigazgató

Ez a Teljesítmény nyilatkozat különböző nyelveken elkészült. Vitás értelmezés esetén az angol verzió az irányadó.

A melléklet a (nyelvsemleges formában megadott) törvényi előírásokon túl önkéntesen megadott, kiegészítő információkat is tartalmaz angolul.

Specific Part

1 Technical description of the product

The fischer injection system FIS V Zero for masonry is a bonded anchor (injection type) consisting of a mortar cartridge with injection mortar fischer FIS V Zero, a perforated sleeve and an anchor rod with hexagon nut and washer or an internal threaded rod. The steel elements are made of zinc coated steel, stainless steel or high corrosion resistant steel.

The anchor rod is placed into a drilled hole filled with injection mortar and is anchored via the bond between steel element, injection mortar and masonry and mechanical interlock.

The product description is given in Annex A.

2 Specification of the intended use in accordance with the applicable European Assessment Document

The performances given in Section 3 are only valid if the anchor is used in compliance with the specifications and conditions given in Annex B.

The verifications and assessment methods on which this European Technical Assessment is based lead to the assumption of a working life of the anchor of at least 50 years. The indications given on the working life cannot be interpreted as a guarantee given by the producer, but are to be regarded only as a means for choosing the right products in relation to the expected economically reasonable working life of the works.

3 Performance of the product and references to the methods used for its assessment

3.1 Mechanical resistance and stability (BWR 1)

Essential characteristic	Performance
Characteristic resistance to steel failure of a single anchor under tension loading	See Annexes C 1 and C 3
Characteristic resistance to steel failure of a single anchor under shear loading with and without lever arm	See Annex C 2 and C 3
Characteristic resistance to pull-out failure or brick breakout failure of a single anchor under tension loading, Reduction factor	See Annex C 5, C 7, C 10, C 13, C 15 and C 16
Characteristic resistance to local brick failure or brick edge failure of a single anchor under shear loading	See Annex C 5, C 7, C 11, C 13 and C 15
Characteristic resistance to brick breakout failure of an anchor group under tension loading	See Annex B 13, B 14, C 4, C 6, C 8, C 9, C 12 and C 14
Characteristic resistance to local brick failure or brick edge failure of an anchor group under shear loading	See Annex B 13, B 14, C 4, C 6, C 8, C 9, C 12 and C 14
Edge distances, spacing, member thickness	See Annex B 2, B 13, C 4, C 6, C 8, C 9, C 12 and C 14
Displacements under tension and shear loading	See Annex C 17
Maximum installation torque	See Annex C 4, C 6, C 8, C 9, C 12 and C 14

3.2 Safety in case of fire (BWR 2)

Essential characteristic	Performance
Reaction to fire	Class A1
Resistance to fire under tension and shear loading with and without lever arm, minimum edge distances and spacing	No performance assessed

3.3 Hygiene, health and the environment (BWR 3)

Essential characteristic	Performance
Content, emission and/or release of dangerous substances	No performance assessed

4 Assessment and verification of constancy of performance (AVCP) system applied, with reference to its legal base

In accordance with the European Assessment Document EAD 330076-01-0604 the applicable European legal act is: [97/177/EC].

The system to be applied is: 1

Installation conditions part 1

Anchor rods with perforated sleeve FIS H K; Installation in perforated and solid brick masonry

Pre-positioned installation:

Installation with render bridge

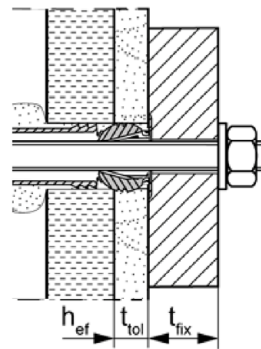
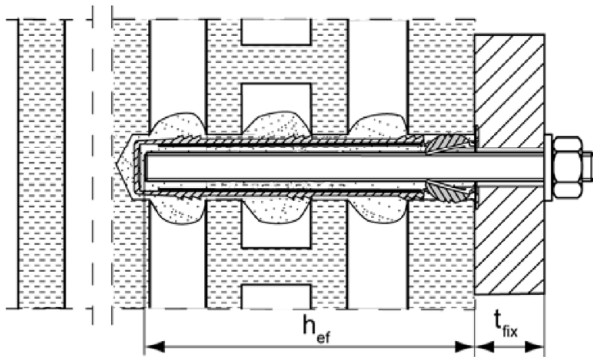

Size of the perforated sleeve: FIS H 12x50 K FIS H 16x85 K FIS H 20x85 K
 FIS H 12x85 K FIS H 16x130 K FIS H 20x130 K

Push through installation:

Installation with render bridge

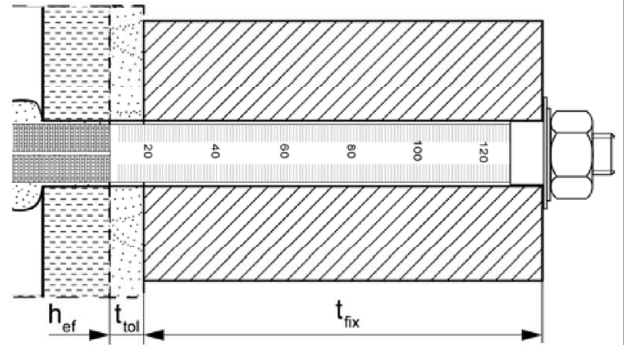
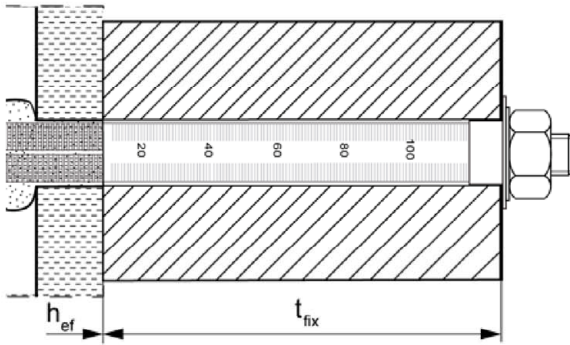

Size of the perforated sleeve: FIS H 18x130/200 K FIS H 22x130/200 K

Internal threaded anchor FIS E with perforated sleeve FIS H K; Installation in perforated and solid brick masonry

Pre-positioned installation:

Installation with render bridge

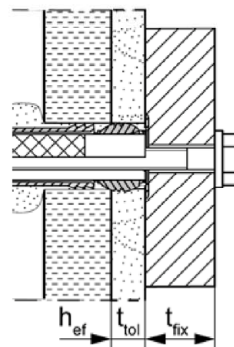
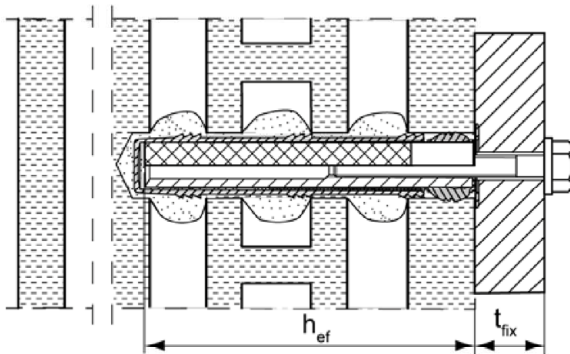

Figures not to scale

h_{ef} = effective embedment depth

t_{tol} = thickness of unbearing layer (e.g. plaster)

t_{fix} = thickness of fixture

fischer injection system FIS V Zero for masonry

Product description
 Installation conditions part 1,
 Anchor rods and internal threaded anchor with perforated sleeve

Annex A 1

Appendix 3 / 38

Installation conditions part 2

Anchor rods without perforated sleeve FIS H K; installation in solid brick masonry

Pre-positioned installation:

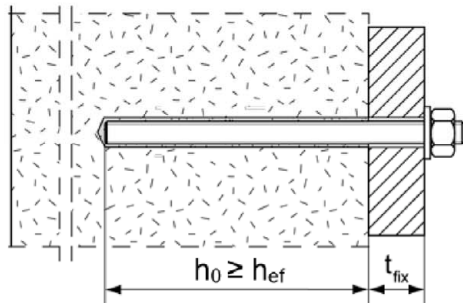

Push through installation: Annular gap filled with mortar

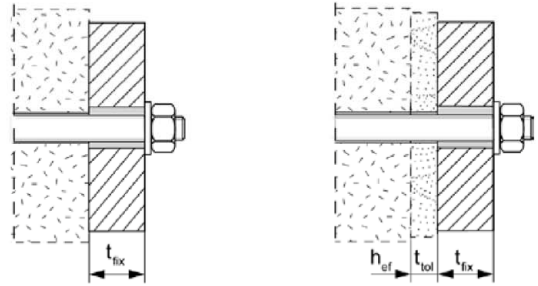

Installation with render bridge

Internal threaded anchors FIS E without perforated sleeve FIS H K; installation in solid brick masonry

Pre-positioned installation:

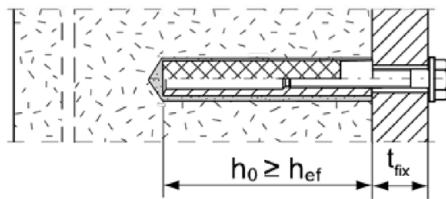

Installation with render bridge

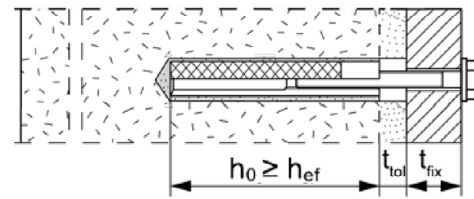

Figures not to scale

h_0 = depth of drill hole

t_{tol} = thickness of unbearing layer (e.g. plaster)

h_{ef} = effective embedment depth

t_{fix} = thickness of fixture

fischer injection system FIS V Zero for masonry

Product description

Installation conditions part 2,
Anchor rods and internal threaded anchor without perforated sleeve

Annex A 2

Appendix 4 / 38

Overview system components part 1

Injection cartridge (shuttle cartridge) with sealing cap

Size: 360 ml, 825 ml

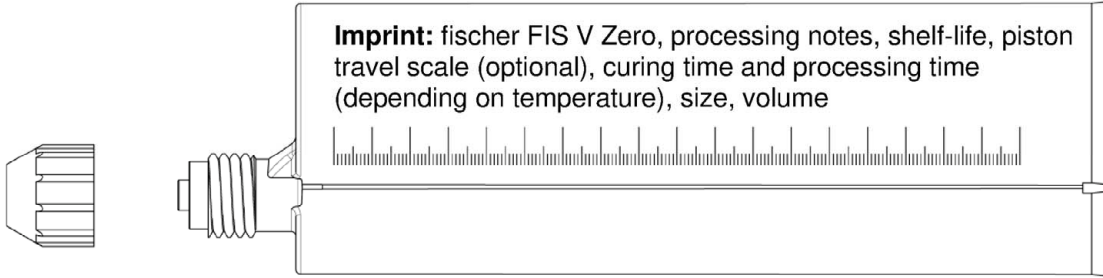

Injection cartridge (coaxial cartridge) with sealing cap

Size: 100 ml, 150 ml, 300 ml, 380 ml, 400 ml, 410 ml

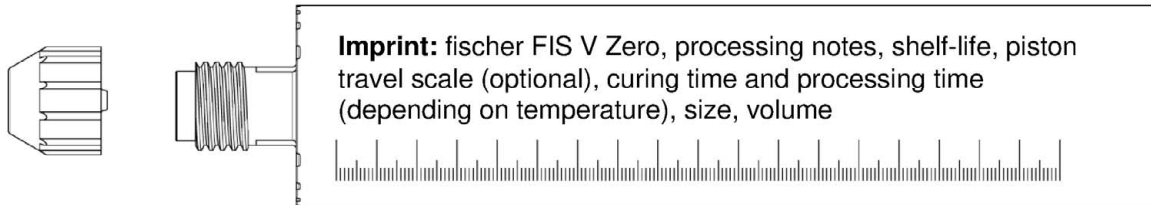

Static mixer MR Plus or FIS JMR (only 825ml) and extension tube

Static mixer MR Plus

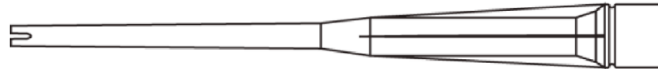

Static mixer JMR Plus



Extension tube



Cleaning brush BS

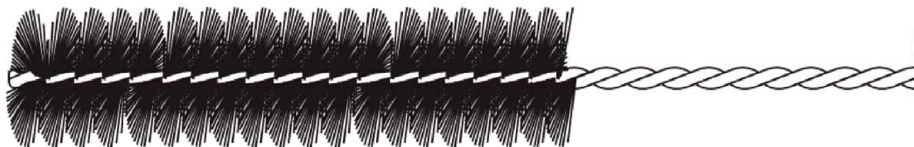

Blow-out pump ABG or ABP

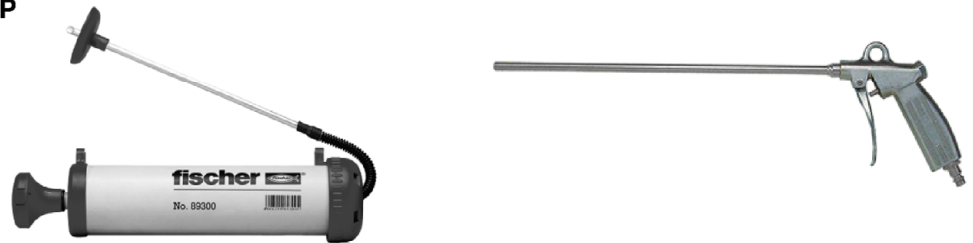

Figures not to scale

fischer injection system FIS V Zero for masonry

Product description

Overview system components part 1: cartridge / static mixer / cleaning tools

Annex A 3

Appendix 5 / 38

Overview system components part 2

fischer anchor rod



Size: M8, M10, M12, M16

Internal threaded anchor FIS E



Size: 11x85 M8
15x85 M10 / M12

Perforated sleeve FIS H K



Size: FIS H 12x50 K
FIS H 12x85 K
FIS H 16x85 K
FIS H 20x85 K



Size: FIS H 16x130 K
FIS H 20x130 K

Perforated sleeve FIS H K (push through installation)



Size:
FIS H 18x130/200 K
FIS H 22x130/200 K

Washer

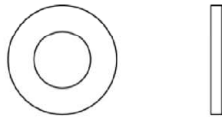

Hexagon nut



Figures not to scale

fischer injection system FIS V Zero for masonry

Product description

Overview system components part 2: Metal parts / perforated sleeves

Annex A 4

Appendix 6 / 38

Table A5.1: Materials

Part	Designation	Material		
1	Injection cartridge	Mortar, hardener; filler		
	Steel grade	Steel	Stainless steel R	High corrosion-resistant steel HCR
		zinc plated	acc. to EN 10088-1:2014 Corrosion resistance class CRC III acc. to EN 1993-1-4:2015	acc. to EN 10088-1:2014 Corrosion resistance class CRC V acc. to EN 1993-1-4:2015
2	Anchor rod	Property class 4.6; 4.8; 5.8 or 8.8; EN ISO 898-1: 2013 zinc plated $\geq 5\mu\text{m}$, ISO 4042:2018 Zn5/An(A2K) or hot-dip galvanised EN ISO 10684:2004 $f_{uk} \leq 1000 \text{ N/mm}^2$ $A_5 > 8\%$ fracture elongation	Property class 50, 70 or 80 EN ISO 3506-1:2020 1.4401; 1.4404; 1.4578; 1.4571; 1.4439; 1.4362; 1.4062; 1.4662; 1.4462; EN 10088-1:2014 $f_{uk} \leq 1000 \text{ N/mm}^2$ $A_5 > 8\%$ fracture elongation	Property class 50 or 80 EN ISO 3506-1:2020 or property class 70 with $f_{yk} = 560 \text{ N/mm}^2$ 1.4565; 1.4529 EN 10088-1:2014 $f_{uk} \leq 1000 \text{ N/mm}^2$ $A_5 > 8\%$ fracture elongation
3	Washer ISO 7089:2000	zinc plated $\geq 5\mu\text{m}$, ISO 4042:2018 Zn5/An(A2K) or hot-dip galvanised EN ISO 10684:2004	1.4401; 1.4404; 1.4578; 1.4571; 1.4439; 1.4362; EN 10088-1:2014	1.4565; 1.4529 EN 10088-1:2014
4	Hexagon nut	Property class 5 or 8; EN ISO 898-2:2012 zinc plated $\geq 5\mu\text{m}$, ISO 4042:2018 Zn5/An(A2K) or hot-dip galvanised ISO 10684:2004	Property class 50, 70 or 80 EN ISO 3506-1:2020 1.4401; 1.4404; 1.4578; 1.4571; 1.4439; 1.4362; EN 10088-1:2014	Property class 50, 70 or 80 EN ISO 3506-1:2020 1.4565; 1.4529 EN 10088-1:2014
5	Internal threaded anchor FIS E	Property class 5.8; EN 10277-1:2008-06 zinc plated $\geq 5\mu\text{m}$, ISO 4042:2018 Zn5/An(A2K)	Property class 70 EN ISO 3506-1:2020 1.4401; 1.4404; 1.4578; 1.4571; 1.4439; 1.4362; EN 10088-1:2014	Property class 70 EN ISO 3506-1:2020 1.4565; 1.4529 EN 10088-1:2014
6	Commercial standard screw or threaded rod for internal threaded anchor FIS E	Property class 5.8 or 8.8; EN ISO 898-1:2013 zinc plated $\geq 5\mu\text{m}$, ISO 4042:2018 Zn5/An(A2K)	Property class 70 EN ISO 3506-1:2020 1.4401; 1.4404; 1.4578; 1.4571; 1.4439; 1.4362; EN 10088-1:2014	Property class 70 EN ISO 3506-1:2020 1.4565; 1.4529 EN 10088-1:2014
7	Perforated sleeve and centring sleeve	PP / PE		



fischer injection system FIS V Zero for masonry

Product description
Materials**Annex A 5**

Appendix 7 / 38

Specifications of intended use (part 1)

Table B1.1: Overview installation and use

		fischer injection system FIS V Zero for masonry	
Hole drilling with hammer drill mode 		all bricks	
Hole drilling with rotary drill mode 		all bricks	
Static and quasi-static load		all bricks	
Use conditions	dry masonry	all bricks	
Installation	Pre-positioned	Anchor rod or internal threaded anchor (in solid brick masonry)	Perforated sleeve with anchor rod or internal threaded anchor (in perforated and solid brick masonry) Size: FIS H 12x50 K FIS H 12x85 K FIS H 16x85 K FIS H 16x130 K FIS H 20x85 K FIS H 20x130 K
	Push through	Anchor rod (in solid brick masonry)	Perforated sleeve with anchor rod (in perforated and solid brick masonry) Size: FIS H 18x130/200 K FIS H 22x130/200 K
Installation and use conditions	condition d/d (dry/dry)	all bricks	
Installation temperature		$T_{i,min} = -10\text{ °C}$ to $T_{i,max} = +40\text{ °C}$	
Service temperature	Temperature range Ta	-40 °C to +40 °C	(max. short term temperature +40 °C max. long term temperature +24 °C)
	Temperature range Tb	-40 °C to +80 °C	(max. short term temperature +80 °C max. long term temperature +50 °C)
	Temperature range Tc	-40 °C to +120 °C	(max. short term temperature +120 °C; max. long term temperature +72 °C)

fischer injection system FIS V Zero for masonry

Intended use
Specifications (part 1)

Annex B 1

Appendix 8 / 38

Specifications of intended use (part 2)

Anchorage subject to:

- Static and quasi-static loads

Base materials:

- Solid brick masonry (base material group b), acc. to Annex B 12
- Hollow brick masonry (base material group c), according to Annex B 12
- Minimum thickness of masonry member is $h_{ef}+30\text{mm}$
- Mortar strength class of the masonry M2,5 at minimum according to EN 998-2:2010
- For other bricks in solid masonry, hollow or perforated masonry the characteristic resistance of the anchor may be determined by job site tests according to EOTA Technical Report TR 053:2016-04 under consideration of the β -factor according to Annex C 16, Table C16.1

Note (only applies to solid bricks):

The characteristic resistance is also valid for larger brick sizes, higher mean compressive strength and higher mean gross dry density of the masonry unit.

Temperature Range:

- **Ta:** from -40°C to +40°C (max. short term temperature +40°C and max. long term temperature +24°C)
- **Tb:** from -40°C to +80°C (max. short term temperature +80°C and max. long term temperature +50°C)
- **Tc:** from -40°C to +120°C (max. short term temperature +120°C and max. long term temperature +72°C)

Use conditions (Environmental conditions):

- Structures subject to dry internal conditions (zinc plated steel, stainless steel or high corrosion resistant steel)
- For all other conditions according to EN 1993-1-4:2015 corresponding to corrosion resistance classes to Annex A 5, Table A5.1.

fischer injection system FIS V Zero for masonry

Intended use
Specifications (part 2)

Annex B 2

Appendix 9 / 38

Specifications of intended use (part 2 continued)

Design:

- The anchorages have to be designed in accordance with EOTA Technical Report TR 054:2021-05, Design method A under the responsibility of an engineer experienced in anchorages and masonry work.

Applies to all bricks, if no other values are specified:

$$N_{Rk} = N_{Rk,b} = N_{Rk,p} = N_{Rk,b,c} = N_{Rk,p,c}$$

$$V_{Rk} = V_{Rk,b} = V_{Rk,c,II} = V_{Rk,c,\perp}$$

For the Calculation of pulling out a brick under tension load $N_{Rk,pb}$ or

pushing out a brick under shear load $V_{Rk,pb}$ see EOTA Technical Report TR 054:2021-05.

$N_{Rk,s}$, $V_{Rk,s}$ and $M^0_{Rk,s}$ see annex C1-C3

Factors for job site tests and displacements see Annex C16

- Verifiable calculation notes and drawings have to be prepared taking account the relevant masonry in the region of the anchorage, the loads to be transmitted and their transmission to the supports of the structure. The position of the anchor is indicated on the design drawings.

Installation:

- Condition d/d: Installation and use in structures subject to dry, internal conditions
- Hole drilling see **Annex B1.1**
- In case of aborted hole: The hole shall be filled with mortar
- Bridging of unbearing layer (e.g. plaster) at perforated brick masonry see Annex B 6, Table B6.1
- Anchor installation carried out by appropriately qualified personnel and under the supervision of the person responsible for technical matters of the site
- Fastening screws or anchor rods (including nut and washer) must comply with the appropriate material and property class of the fischer internal threaded anchor FIS E.
- Minimum curing time see Annex B 8, Table B8.2
- Commercial standard threaded rods, washers and hexagon nuts may also be used if the following requirements are fulfilled:

Material dimensions and mechanical properties of the metal parts according to the specifications are given in Annex A 5, Table 5.1

Conformation of material and mechanical properties of the metal parts by inspection certificate 3.1 according to EN 10204:2004, the documents shall be stored

Marking of the anchor rod with the effective embedment depth. This may be done by the manufacturer of the rod or by a person on job site

fischer injection system FIS V Zero for masonry

Intended use
Specifications (part 2 continued)

Annex B 3

Appendix 10 / 38

Table B4.1: Installation parameters for anchor rods in solid bricks without perforated sleeves

Anchor rod		Thread	M8	M10	M12	M16
Nominal drill hole diameter		d_0 [mm]	10	12	14	18
Effective embedment depth $h_{ef}^{1)}$ in solid brick		$h_{ef,min}$ [mm]	50			
(depth of drill hole $h_0 = h_{ef}$)		$h_{ef,max}$ [mm]	$h-30, \leq 200$			
Diameter of clearance hole in the fixture	pre-positioned installation	$d_f \leq$ [mm]	9	12	14	18
	push through installation	$d_f \leq$ [mm]	11	14	16	20
Diameter of cleaning brush		$d_b \geq$ [mm]	see Table B8.1			
Maximum installation torque		$\max T_{inst}$ [Nm]	see parameters of brick Annex C			

¹⁾ $h_{ef,min} \leq h_{ef} \leq h_{ef,max}$ is possible.

fischer anchor rods M8, M10, M12, M16

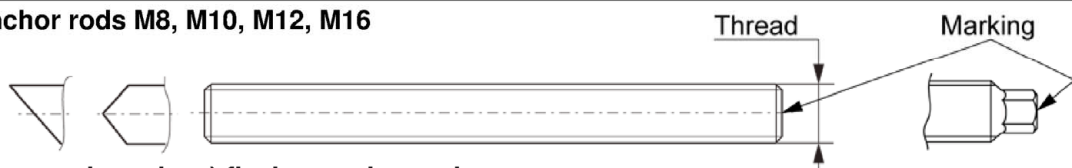

Marking (on random place) fischer anchor rod:

Steel zinc plated PC ¹⁾ 8.8	• or +	Steel hot-dip galvanised PC ¹⁾ 8.8	•
High corrosion resistant steel HCR PC ¹⁾ 50	•	High corrosion resistant steel HCR PC ¹⁾ 70	–
High corrosion resistant steel HCR PC ¹⁾ 80	(Stainless steel R property class 50	~
Stainless steel R property class 80	*		

Alternatively: Colour coding according to DIN 976-1: 2016;
property class 4.6 marking according to EN ISO 898-1:2013

¹⁾ PC = property class

Installation conditions:

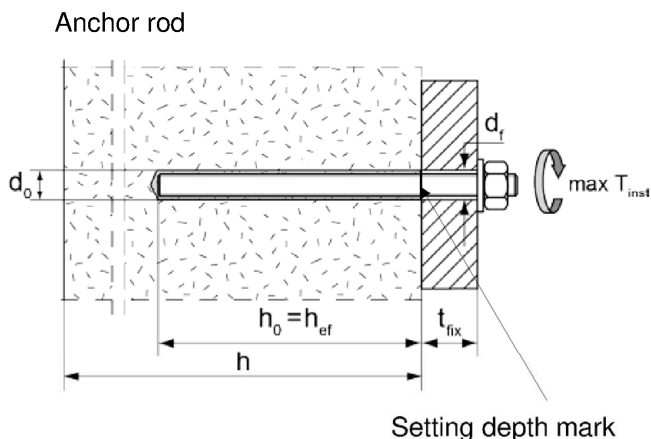

Figures not to scale

fischer injection system FIS V Zero for masonry

Intended use
Installation parameters for anchor rods without perforated sleeve

Annex B 4
Appendix 11 / 38

Table B5.1: Installation parameters for internal threaded anchors FIS E in solid bricks without perforated sleeves

Internal threaded anchor FIS E		11x85 M8	15x85 M10	15x85 M12
Diameter of anchor	d_H [mm]	11	15	
Nominal drill hole diameter	d_0 [mm]	14	18	
Length of anchor	L_H [mm]	85		
Effective embedment depth	$h_0 = h_{ef}$ [mm]	85		
Diameter of cleaning brush	$d_b \geq$ [mm]	see Table B8.1		
Maximum installation torque	$\max T_{inst}$ [Nm]	see parameters of brick Annex C		
Diameter of clearance hole in the fixture	d_f [mm]	9	12	14
Screw-in depth	$l_{E,min}$ [mm]	8	10	12
	$l_{E,max}$ [mm]	60		

fischer Internal threaded anchor FIS E

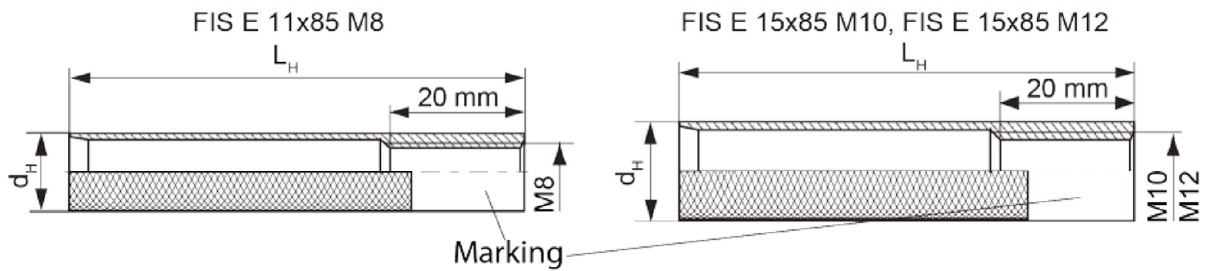

Marking:

Size, e.g. **M8**, Stainless steel: R, e.g. **M8 R**, High corrosion-resistant steel: HCR, e.g. **M8 HCR**

Installation conditions:

Internal threaded anchor

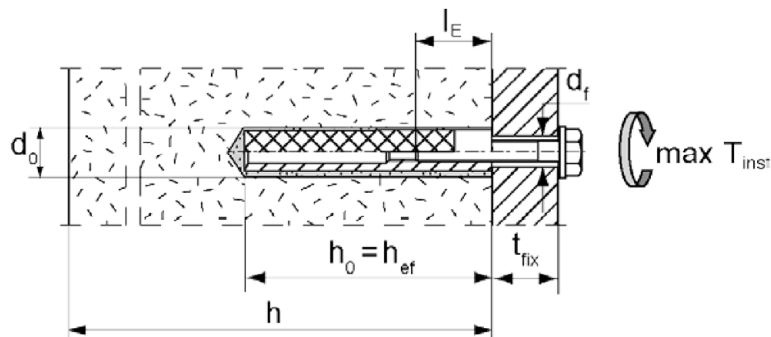

Figures not to scale

fischer injection system FIS V Zero for masonry

Intended use

Installation parameters for internal threaded rods FIS E without perforated sleeve

Annex B 5

Appendix 12 / 38

Table B6.1: Installation parameters for anchor rods and internal threaded anchors FIS E with perforated sleeves (pre-positioned installation)

perforated sleeve FIS H K		12x50	12x85 ²⁾	16x85	16x130 ²⁾	20x85	20x130 ²⁾
Nominal drill hole diameter $d_0 = D_{\text{sleeve, nom}}$	d_0 [mm]	12		16		20	
Depth of drill hole	h_0 [mm]	55	90	90	135	90	135
Effective embedment depth	$h_{\text{ef, min}}$ [mm]	50	65	85	110	85	110
	$h_{\text{ef, max}}$ [mm]	50	85	85	130	85	130
Size of threaded rod	[-]	M8		M8 and M10		M12 and M16	
Size of internal threaded anchor FIS E		-	-	11x85	-	15x85	-
Diameter of cleaning brush ¹⁾	$d_b \geq$ [mm]	see Table B8.1					
Maximum installation torque	$\max T_{\text{inst}}$ [Nm]	see parameters of brick Annex C					

¹⁾ Only for solid areas in hollow bricks and solid bricks.

²⁾ Bridging of unbearing layer (e.g. plaster) is possible. When reducing the effective embedment depth $h_{\text{ef, min}}$, the values of the next shorter perforated sleeve of the same diameter must be used. The smaller value of characteristic resistance must be taken.

Perforated sleeve

FIS H 12x50 K; FIS H 12x85 K; FIS H 16x85 K; FIS H 16x130 K;
FIS H 20x85 K; FIS H 20x130 K

Marking:

Size $D_{\text{sleeve, nom}} \times L_{\text{sleeve}}$
(e.g.: 16x85)

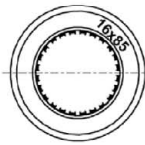

$D_{\text{sleeve, nom}}$

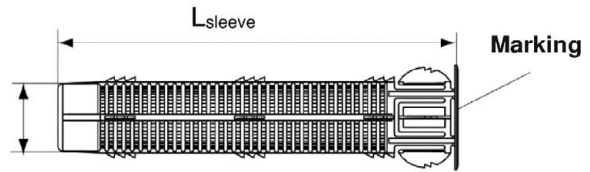

fischer Internal threaded anchor FIS E

FIS E 11x85 M8

FIS E 15x85 M10, FIS E 15x85 M12

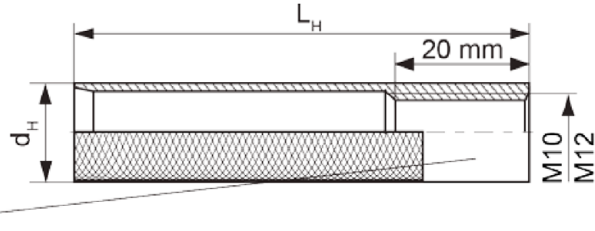
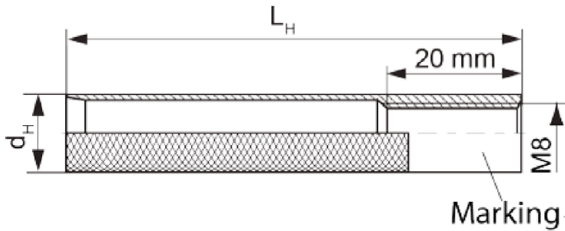

Installation conditions:

Anchor rod with perforated sleeve

Internal threaded anchor with perforated sleeve

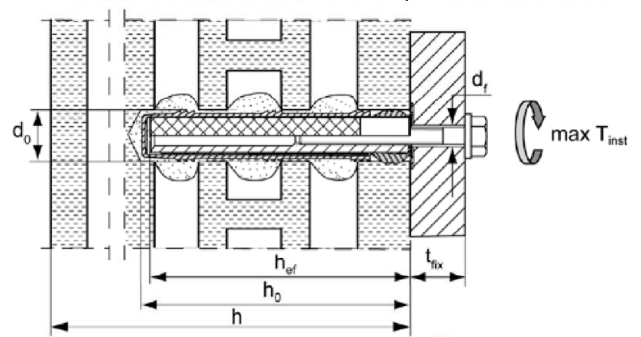
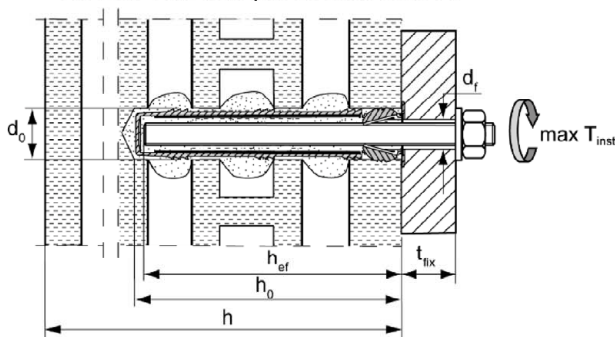

Figures not to scale

fischer injection system FIS V Zero for masonry

Intended use

Installation parameters for anchor rods and internal threaded anchors FIS E with perforated sleeve (pre-positioned installation)

Annex B 6

Appendix 13 / 38

Table B7.1: Installation parameters for anchor rods with perforated sleeves (push through installation)

Perforated sleeve FIS H K		18x130/200		22x130/200	
Nominal sleeve diameter	$D_{\text{sleeve,nom}}$ [mm]	16		20	
Nominal drill hole diameter	d_0 [mm]	18		22	
Depth of drill hole	h_0 [mm]	135			
Effective embedment depth	h_{ef} [mm]	≥ 130			
Diameter of cleaning brush ¹⁾	$d_b \geq$ [mm]	see Table B8.1			
Size of threaded rod	[-]	M10	M12	M16	
Maximum installation torque	$\max T_{\text{inst}}$ [Nm]	see parameters of brick Annex C			
Thickness of fixture	$t_{\text{fix,max}}$ [mm]	200			

¹⁾ Only for solid areas in hollow bricks and solid bricks.

Perforated sleeve

FIS H 18x130/200 K; FIS H 22x130/200 K

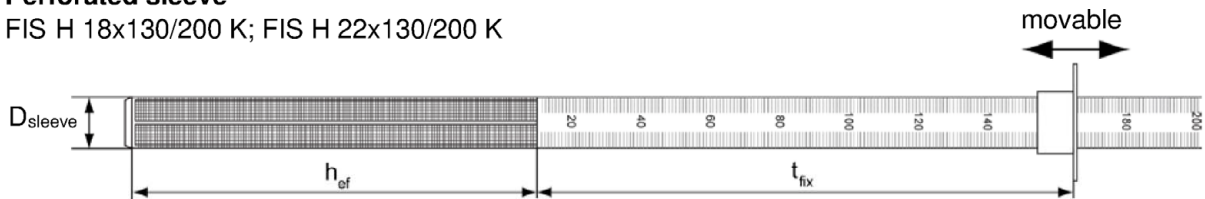

Installation conditions:

Anchor rod with perforated sleeve

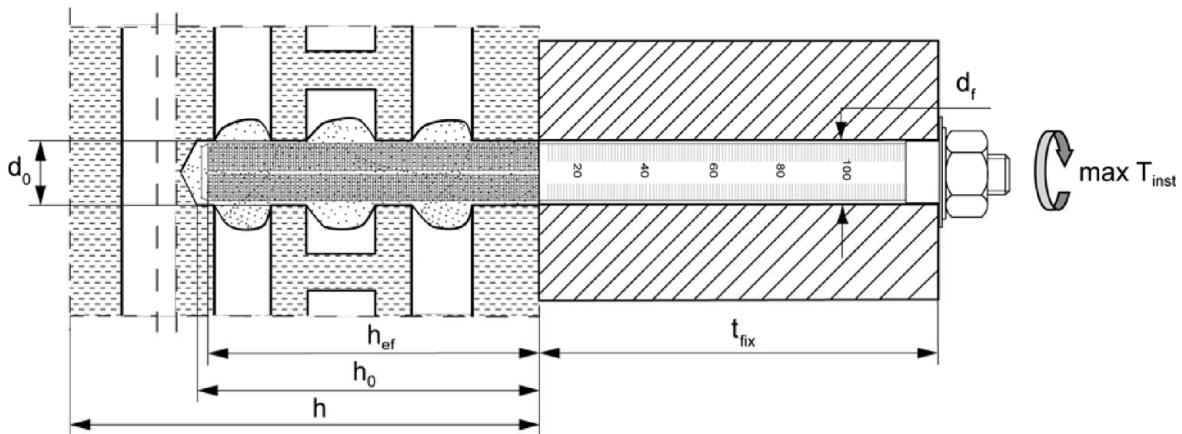

Figures not to scale

fischer injection system FIS V Zero for masonry

Intended use
Installation parameters for anchor rods with perforated sleeves (push through installation)

Annex B 7
Appendix 14 / 38

Table B8.1: Parameters of the cleaning brush BS (steel brush with steel bristles)

The size of the cleaning brush refers to the drill hole diameter

Nominal drill hole diameter	d_0 [mm]	10	12	14	16	18	20	22
Steel brush diameter	d_b [mm]	11	14	16	20	20	25	25

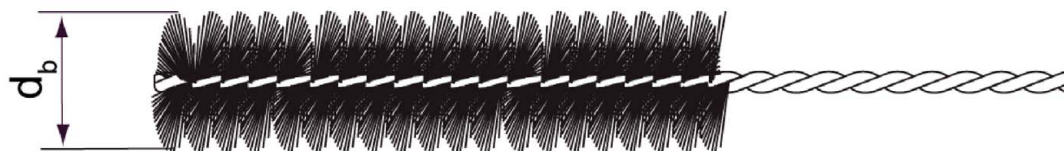

Only for solid areas in hollow bricks and solid bricks

Table B8.2: Maximum processing times and minimum curing times
(During the curing time of the mortar the temperature of the anchoring base may not fall below the listed minimum temperature)

Temperature at anchoring base [°C]	Maximum processing time t_{work}	Minimum curing time t_{cure}
	FIS V Zero	FIS V Zero
-10 to -5 ¹⁾	6 h	72 h
> -5 to 0 ¹⁾	2 h	24 h
> 0 to 5 ¹⁾	45 min	12 h
> 5 to 10	20 min	6 h
> 10 to 15	8 min	3 h
> 15 to 20	5 min	2 h
> 20 to 25	3 min	1 h
> 25 to 30	2 min	45 min
> 30 to 40	1 min	30 min

¹⁾ Minimum cartridge temperature +5°C

Figures not to scale



fischer injection system FIS V Zero for masonry

Intended use
Parameters of the cleaning brush (steel brush)
Processing time and curing time

Annex B 8
Appendix 15 / 38

Installation instruction part 1

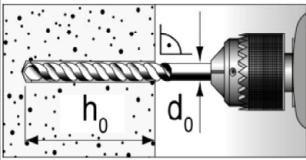
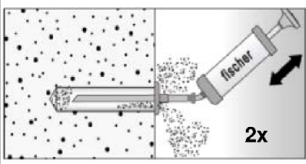
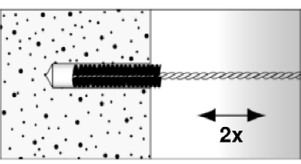
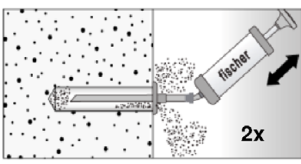
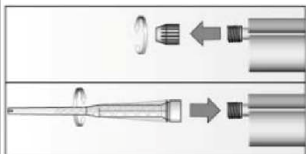
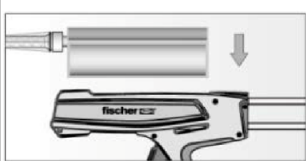
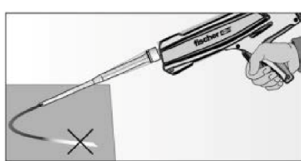
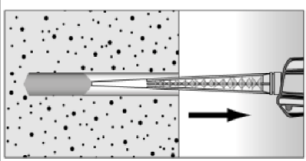
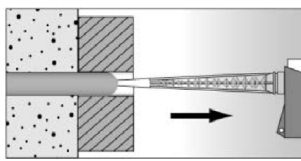
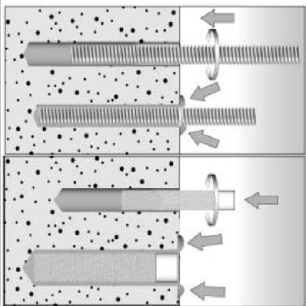
Installation in solid brick without perforated sleeve

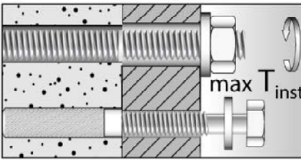
1		<p>Drill the hole (drilling method see Annex C of the respective brick) depth of drill hole h_0 and nominal drill hole diameter d_0 see Table B4.1; B5.1</p>	
2			 <p>Blow out the drill hole twice. Brush twice and blow out twice again.</p>
3		<p>Remove the sealing cap. Screw on the static mixer. (the spiral in the static mixer must be clearly visible)</p>	
4		<p>Place the cartridge into a suitable dispenser</p>	 <p>Extrude approximately 10 cm of material out until the resin is evenly grey in colour. Do not use mortar that is not uniformly grey.</p>
5		<p>Fill approximately 2/3 of the drill hole with mortar beginning from the bottom of the hole¹⁾. Avoid bubbles.</p>	 <p>For push through installation fill the annular gap with mortar.</p>
6		<p>Only use clean and oil-free metal parts. Mark the setting depth. Insert the anchor rod or internal threaded anchor FIS E by hand.</p> <p>Recommendation: Rotation back and forth of the anchor rod or internal threaded anchor FIS E makes pushing easy.</p> <p>When reaching the setting depth mark, excess mortar must emerge from the mouth of the drill hole.</p>	
7		<p>Do not touch. Minimum curing time see Table B8.2</p>	 <p>Mounting the fixture. $\max T_{inst}$ see parameter of brick.</p>

¹⁾ Exact volume of mortar see manufacturer's specifications





fischer injection system FIS V Zero for masonry

Intended use
Installation instruction part 1
Installation in solid brick without perforated sleeve

Annex B 9
Appendix 16 / 38

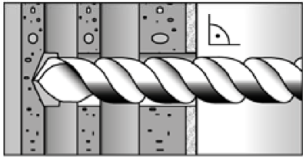
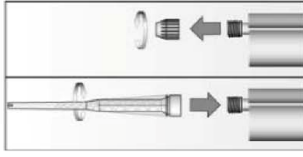
Installation instruction part 2

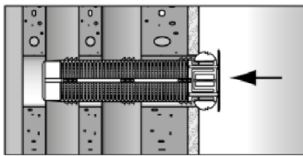
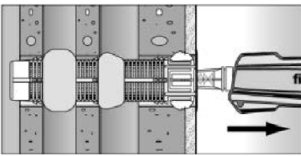
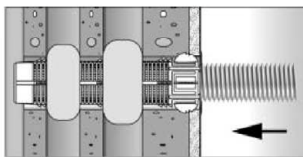
Installation in perforated or solid brick with perforated sleeve (pre-positioned installation)

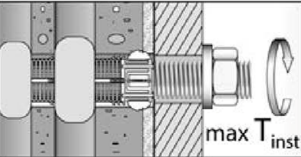
1		<p>Drill the hole (drilling method see Annex C of the respective brick). depth of drill hole h_0 and nominal drill hole diameter d_0 see Table B6.1</p>	<p>When install perforated sleeves in solid bricks or solid areas of hollow bricks, also clean the hole by blowing out and brushing.</p>
2		<p>Remove the sealing cap. Screw on the static mixer. (the spiral in the static mixer must be clearly visible)</p>	
3		<p>Place the cartridge into a suitable dispenser.</p>	 <p>Extrude approximately 10 cm of material out until the resin is evenly grey in colour. Do not use mortar that is not uniformly grey.</p>
4		<p>Insert the perforated sleeve flush with the surface of the masonry or plaster.</p>	 <p>Fill the perforated sleeve completely with mortar beginning from the bottom of the hole. ¹⁾</p>
5		<p>Only use clean and oil-free metal parts. Mark the setting depth. Insert the anchor rod or the internal threaded anchor FIS E by hand.</p> <p>Recommendation: Rotation back and forth of the anchor rod or internal threaded anchor FIS E makes pushing easy until reaching the setting depth mark (anchor rod) or flush with the surface (internal threaded anchor).</p>	
6		<p>Do not touch. Minimum curing time see Table B8.2</p>	 <p>Mounting the fixture. max T_{inst} see parameter of brick.</p>

¹⁾ Exact volume of mortar see manufacturer's specification.

fischer injection system FIS V Zero for masonry

Intended use

Installation instruction part 2

Installation in perforated or solid brick with perforated sleeve (pre-positioned installation)

Annex B 10

Appendix 17 / 38

Installation instruction part 3

Installation in perforated or solid brick with perforated sleeve (push through installation)

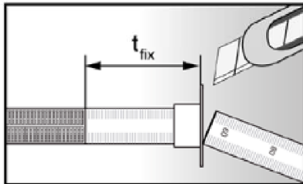
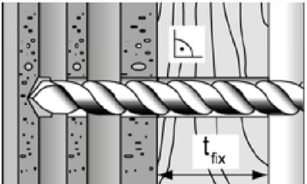
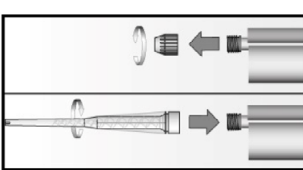
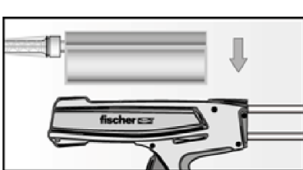
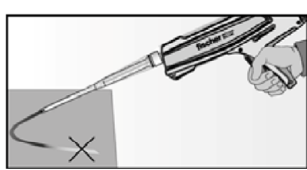
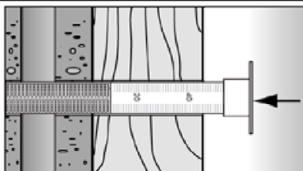
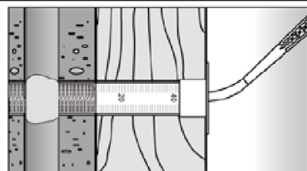
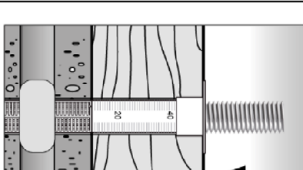
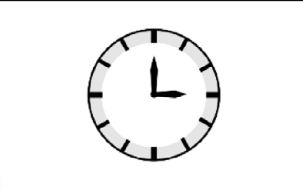
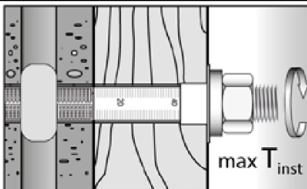
1		<p>Push the movable stop up to the correct thickness of fixture and cut the overlap.</p>		<p>Drill the hole through the fixture. Depth of drill hole ($h_0 + t_{fix}$) and nominal drill hole diameter d_0 see Table B7.1</p>
2		<p>Remove the sealing cap. Screw on the static mixer. (the spiral in the static mixer must be clearly visible)</p>		
3		<p>Place the cartridge into a suitable dispenser.</p>		<p>Extrude approximately 10 cm of material out until the resin is evenly grey in colour. Do not use mortar that is not uniformly grey.</p>
4		<p>Insert the perforated sleeve flush with the surface of the fixture into the drill hole.</p>		<p>Fill the sleeve with mortar beginning from the bottom of the hole. ¹⁾ For deep drill holes use an extension tube.</p>
5		<p>Only use clean and oil-free metal parts. Mark the setting depth. Insert the anchor rod by hand. Recommendation: Rotation back and forth of the anchor rod makes pushing easy until reaching the setting depth mark (anchor rod).</p>		
6		<p>Do not touch. Minimum curing time see Table B8.2</p>		<p>Mounting the fixture. max T_{inst} see parameter of brick.</p>

¹⁾ Exact volume of mortar see manufacturer's specification.

fischer injection system FIS V Zero for masonry

Intended use

Installation instruction part 3

Installation in perforated or solid brick with perforated sleeve (push through installation)

Annex B 11

Appendix 18 / 38

Table B12.1: Overview of assessed bricks

Kind of masonry	Brick format [mm]	Mean compressive strength [N/mm ²]	Main country of origin	Mean gross dry density ρ [kg/dm ³]	Annex
Solid brick Mz					
Solid brick Mz	≥ 230x108x55	36 - 48	Denmark	≥2,0	C4/C5
Solid calcium silicate (sand - lime) brick KS / perforated calcium silicate (sand - lime) brick KSL					
Solid calcium silicate brick KS	NF ≥240x115x71	8- 20	Germany	≥2,0	C6/C7
Perforated calcium silicate brick KSL	3DF 240x175x113	8 - 16	Germany	≥1,6	C8 – C11
Vertical perforated brick HLz					
Vertical perforated brick HLz	230x108x55	6 - 16	Denmark	≥1,6	C12/C13
Lightweight aggregate concrete hollow block Hbl					
Lightweight aggregate concrete hollow block Hbl	500x200x200	2 - 4	France	≥1,0	C14/C15

Picture B12.1: Overview dimensions of perforated and hollow bricks

Perforated calcium silicate (sand-lime) brick KSL, 3DF, EN 771-2:2015; e.g. KS Wending according to Annex C 8
 Vertical perforated brick HLz, EN 771-1:2015; e.g. Wienerberger according to Annex C 12

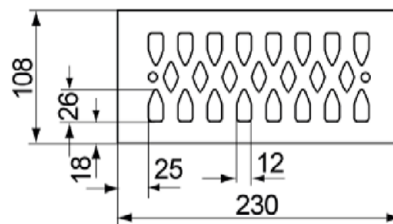
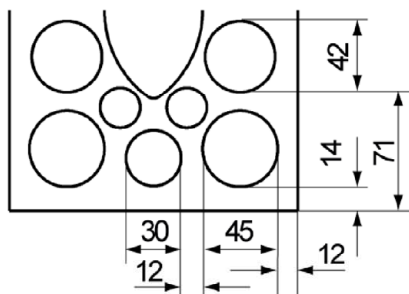

Lightweight aggregate concrete hollow block Hbl, EN 771-3:2015; e.g. Sepa according to Annex C 14

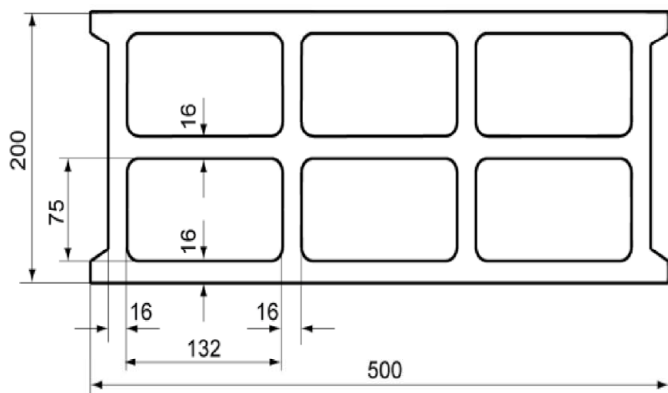

Measures in [mm]

Figures not to scale

fischer injection system FIS V Zero for masonry

Intended use
 Overview of assessed bricks
 Overview dimensions of perforated and hollow bricks

Annex B 12
 Appendix 19 / 38

Spacing and edge distance

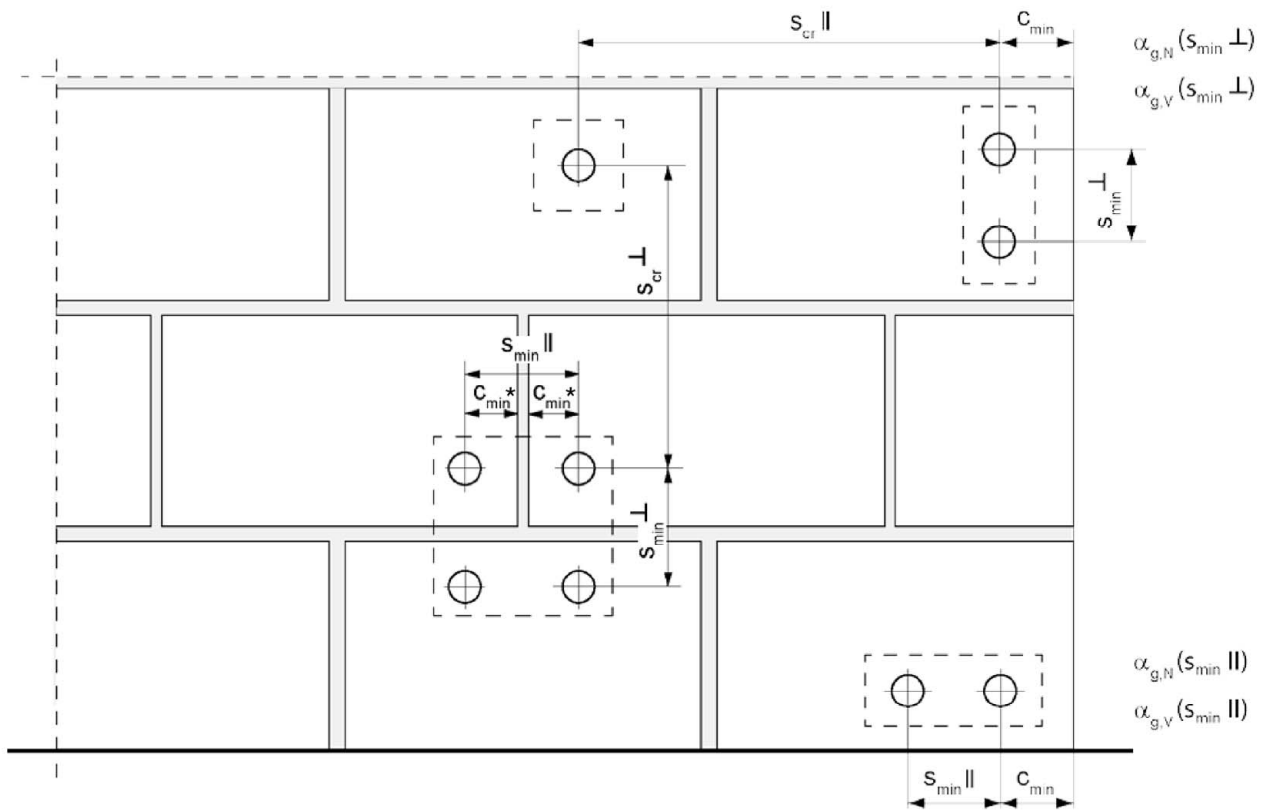

* Only, if vertical joints are not completely filled with mortar

- $s_{min II}$ = Minimum spacing parallel to horizontal joint
- $s_{min \perp}$ = Minimum spacing perpendicular to horizontal joint
- $s_{cr II}$ = Characteristic spacing parallel to horizontal joint
- $s_{cr \perp}$ = Characteristic spacing perpendicular to horizontal joint
- $C_{cr} = C_{min}$ = Edge distance
- $\alpha_{g,N} (s_{min II})$ = Group factor for tension load, anchor group parallel to horizontal joint
- $\alpha_{g,V} (s_{min II})$ = Group factor for shear load, anchor group parallel to horizontal joint
- $\alpha_{g,N} (s_{min \perp})$ = Group factor for tension load, anchor group vertical to horizontal joint
- $\alpha_{g,V} (s_{min \perp})$ = Group factor for shear load, anchor group vertical to horizontal joint

fischer injection system FIS V Zero for masonry

Intended use
Spacing and edge distance

Annex B 13

Appendix 20 / 38

Spacing and edge distance (continuation)

For $s \geq s_{cr}$ $\alpha_g = 2$

For $s_{min} \leq s < s_{cr}$ α_g according to installation parameters of brick Annex C

Group of 2 anchors

$$N^{g_{Rk}} = \alpha_{g,N} \cdot N_{Rk} ; \quad V^{g_{Rk,b}} = V^{g_{Rk,c,II}} = V^{g_{Rk,c,\perp}} = \alpha_{g,V} \cdot V_{Rk}$$

Group of 4 anchors

$$N^{g_{Rk}} = \alpha_{g,N} (s_{minII}) \cdot \alpha_{g,N} (s_{min\perp}) \cdot N_{Rk} ;$$

$$V^{g_{Rk,b}} = V^{g_{Rk,c,II}} = V^{g_{Rk,c,\perp}} = \alpha_{g,V} (s_{minII}) \cdot \alpha_{g,V} (s_{min\perp}) \cdot V_{Rk}$$

with N_{Rk} and $\alpha_{g,N}$ depending on s_{minII} or $s_{min\perp}$ acc. to Annex C

with V_{Rk} and $\alpha_{g,V}$ depending on s_{minII} or $s_{min\perp}$ acc. to Annex C

fischer injection system FIS V Zero for masonry

Intended use
Spacing and edge distance (continuation)

Annex B 14

Appendix 21 / 38

Table C1.1: Characteristic resistance to **steel failure** of a single anchor under **tension loading** of **fischer anchor rods** and **standard threaded rods**

Anchor rod / standard threaded rod		M8 ³⁾	M10 ³⁾	M12	M16		
Characteristic resistance to steel failure under tension loading							
Characteristic resistance $N_{Rk,s}$	Steel zinc plated	4.6	15(13)	23(21)	33	63	
		4.8	15(13)	23(21)	33	63	
		5.8	19(17)	29(27)	43	79	
	Stainless steel R and High corrosion resistant steel HCR	Property class	8.8	29(27)	47(43)	68	126
			50	19	29	43	79
			70	26	41	59	110
			80	30	47	68	126

Partial factors ¹⁾						
Partial factors $\gamma_{Ms,N}$	Steel zinc plated	4.6	[-]	2,00		
		4.8		1,50		
		5.8		1,50		
	Stainless steel R and High corrosion resistant steel HCR	Property class		8.8	1,50	
				50	2,86	
				70	1,50 ²⁾ / 1,87	
				80	1,60	

¹⁾ In absence of other national regulations

²⁾ Only for fischer FIS A made of high corrosion-resistant steel HCR

³⁾ Values in brackets are valid for undersized threaded rods with smaller stress area A_s for hot dip galvanised standard threaded rods according to EN ISO 10684:2004+AC:2009

fischer injection system FIS V Zero for masonry

Performances

Characteristic resistance to steel failure of a single anchor under tension loading of fischer anchor rods and standard threaded rods

Annex C 1

Table C2.1: Characteristic resistance to **steel failure** of a single anchor under **shear loading** with and without lever arm of **fischer anchor rods** and **standard threaded rods**

Anchor rod / standard threaded rod		M8 ³⁾	M10 ³⁾	M12	M16			
Characteristic resistance to steel failure under shear loading								
without lever arm								
Characteristic resistance $V_{Rk,s}$	Steel zinc plated	Property class	[kN]	4.6	9(8)	14(13)	20	38
				4.8	9(8)	14(13)	20	38
				5.8	11(10)	17(16)	25	47
				8.8	15(13)	23(21)	34	63
	Stainless steel R and High corrosion resistant steel HCR	Property class	[kN]	50	9	15	21	39
				70	13	20	30	55
				80	15	23	34	63
with lever arm								
Characteristic resistance $M^0_{Rk,s}$	Steel zinc plated	Property class	[Nm]	4.6	15(13)	30(27)	52	133
				4.8	15(13)	30(27)	52	133
				5.8	19(16)	37(33)	65	166
				8.8	30(26)	60(53)	105	266
	Stainless steel R and High corrosion resistant steel HCR	Property class	[Nm]	50	19	37	65	166
				70	26	52	92	232
				80	30	60	105	266
Partial factors ¹⁾								
Partial factors $\gamma_{Ms,V}$	Steel zinc plated	Property class	[-]	4.6	1,67			
				4.8	1,25			
				5.8	1,25			
				8.8	1,25			
	Stainless steel R and High corrosion resistant steel HCR	Property class	[-]	50	2,38			
				70	1,25 ²⁾ / 1,56			
				80	1,33			

¹⁾ In absence of other national regulations

²⁾ Only for fischer FIS A made of high corrosion-resistant steel HCR

³⁾ Values in brackets are valid for undersized threaded rods with smaller stress area A_s for hot dip galvanised standard threaded rods (M8 resp. M10) according to EN ISO 10684:2004+AC:2009.

fischer injection system FIS V Zero for masonry

Performances

Characteristic resistance to steel failure of a single anchor under shear loading with and without lever arm of fischer anchor rods and standard threaded rods

Annex C 2

Appendix 23 / 38

Table C3.1: Characteristic resistance to **steel failure** of a single anchor under **tension / shear loading** of **internal threaded anchors FIS E**

fischer internal threaded anchor FIS E			M8	M10	M12		
Characteristic resistance to steel failure under tension loading							
Characteristic resistance with screw	$N_{Rk,s}$	Property class 5.8	[kN]	18	29	42	
		Property class 70		R	26	41	59
		HCR		26	41	59	
Partial factors ¹⁾							
Partial factors	$\gamma_{Ms,N}$	Property class 5.8	[-]	1,50			
		Property class 70		R	1,87		
		HCR		1,87			
Characteristic resistance to steel failure under shear loading							
without lever arm							
Characteristic resistance with screw	$V_{Rk,s}$	Property class 5.8	[kN]	9	15	21	
		Property class 70		R	13	20	30
		HCR		13	20	30	
with lever arm							
Characteristic resistance	$M^0_{Rk,s}$	Property class 5.8	[Nm]	19	37	65	
		Property class 70		R	26	52	92
		HCR		26	52	92	
Partial factors ¹⁾							
Partial factors	$\gamma_{Ms,V}$	Property class 5.8	[-]	1,25			
		Property class 70		R	1,56		
		HCR		1,56			

¹⁾ In absence of other national regulations

fischer injection system FIS V Zero for masonry

Performances

Characteristic resistance to steel failure of a single anchor under tension / shear loading of internal threaded anchors FIS E

Annex C 3

Appendix 24 / 38

Solid brick Mz, EN 771-1:2015

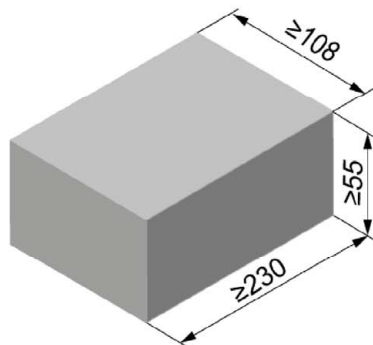

Solid brick Mz, EN 771-1:2015			
Producer	e.g. Wienerberger		
Nominal dimensions [mm]	length L	width W	height H
	≥ 230	≥ 108	≥ 55
Mean gross dry density ρ [kg/dm ³]	≥ 2,0		
Mean compressive strength [N/mm ²]	36 / 48		
Standard	EN 771-1:2015		

Table C4.1: Installation parameters

Anchor rod	M8		M10		M12		M16		-		-		
Internal threaded anchor FIS E	-		-		-		-		M8		M10	M12	
									11x85		15x85		
Anchor rod and internal threaded anchor FIS E without perforated sleeve													
Effective embedment depth h_{ef} [mm]	50	80	50	80	50	80	50	80	85				
Max. installation torque $\max T_{inst}$ [Nm]	10								10				
General installation parameters													
Edge distance c_{min}	100												
Spacing	$s_{min II}$	100											
	$s_{cr II}$ [mm]	3 x h_{ef}											
	$s_{min \perp}$	100											
	$s_{cr \perp}$	3 x h_{ef}											
Drilling method													
Hole drilling with rotary drill mode or hammer drilling with hard metal hammer drill													

Table C4.2: Group factors

Anchor rods	M8		M10		M12		M16		-		-	
Internal threaded anchor FIS E	-		-		-		-		M8		M10	M12
									11x85		15x85	
Group factors	$\alpha_{g,N} (s_{min II})$	[-]	1,81									
	$\alpha_{g,V} (s_{min II})$		1,49									
	$\alpha_{g,N} (s_{min \perp})$		1,74									
	$\alpha_{g,V} (s_{min \perp})$		1,49									

fischer injection system FIS V Zero for masonry

Performances
Solid brick Mz, dimensions, installation parameters

Annex C 4
Appendix 25 / 38

Solid brick Mz, EN 771-1:2015

Table C5.1: Characteristic resistance to pull-out failure or brick breakout failure of a single anchor under tension loading

Anchor rod	M8		M10		M12		M16		-	-
Internal threaded anchor FIS E	-		-		-		-		M8	M10 M12
	-		-		-		-		11x85	15x85
Tension resistance $N_{RK} = N_{RK,p} = N_{RK,b} = N_{RK,p,c} = N_{RK,b,c}$ [kN] depending on the mean compressive strength f_b ; Installation and use condition d/d; (temperature range 24/40°C)										
Mean compressive strength f_b	Effective embedment depth h_{ef} [mm]									
	50	80	50	80	50	80	50	80	85	
36 N/mm ²	2,5	3,0	3,0	3,0	3,0	3,0	3,0	3,0	4,5	2,5
48 N/mm ²	3,0	3,5	3,5	3,5	3,5	3,5	3,5	3,5	5,0	3,0

Table C5.2: Characteristic resistance to local brick failure or brick edge failure of a single anchor under shear loading

Anchor rod	M8		M10		M12		M16		-	-
Internal threaded anchor FIS E	-		-		-		-		M8	M10 M12
	-		-		-		-		11x85	15x85
Tension resistance $N_{RK} = N_{RK,p} = N_{RK,b} = N_{RK,p,c} = N_{RK,b,c}$ [kN] depending on the mean compressive strength f_b ; Installation and use condition d/d; (temperature range 50/80°C and 72/120°C)										
Mean compressive strength f_b	Effective embedment depth h_{ef} [mm]									
	50	80	50	80	50	80	50	80	85	
36 N/mm ²	1,5	2,0	2,0	2,0	2,0	2,0	2,0	2,0	3,5	1,5
48 N/mm ²	1,5	2,5	2,5	2,5	2,5	2,5	2,5	2,5	4,0	1,5

Table C5.2: Characteristic resistance to local brick failure or brick edge failure of a single anchor under shear loading

Anchor rod	M8		M10		M12		M16		-	-
Internal threaded anchor FIS E	-		-		-		-		M8	M10 M12
	-		-		-		-		11x85	15x85
Shear resistance $V_{RK} = V_{RK,b} = V_{RK,c,II} = V_{RK,c,I}$ [kN] depending on the mean compressive strength f_b ; Installation and use condition d/d; (temperature range 24/40°C, 50/80°C and 72/120°C)										
Mean compressive strength f_b	Effective embedment depth h_{ef} [mm]									
	50	80	50	80	50	80	50	80	85	
36 N/mm ²	2,5	4,5	2,5	4,5	2,5	4,5	2,5	4,5	2,5	2,5
48 N/mm ²	3,0	5,0	3,0	5,0	3,0	5,0	3,0	5,0	3,0	3,0

Factor for job site tests see annex C16 and displacements see annex C17

fischer injection system FIS V Zero for masonry

Performances

Solid brick Mz, Characteristic resistance under tension and shear loading

Annex C 5

Appendix 26 / 38

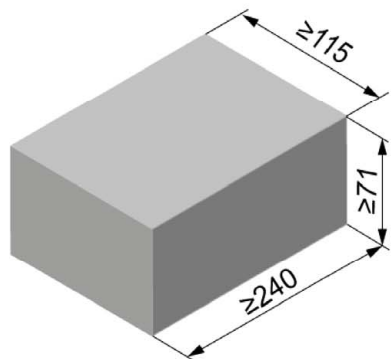
Solid calcium silicate (sand-lime) brick KS, NF, EN 771-2:2015

Solid calcium silicate (sand-lime) brick KS, NF, EN 771-2:2015			
Producer	---		
Nominal dimensions [mm]	length L	width W	height H
	≥ 240	≥ 115	≥ 71
Mean gross dry density [kg/dm ³]	≥ 2,0		
Mean compressive strength [N/mm ²]	12 / 16 / 20		
Standard	EN 771-2:2015		

Table C6.1: Installation parameters

Anchor rod	M8		M10		M12		M16		-		-	
Internal threaded anchor FIS E	-		-		-		-		M8		M10	M12
									11x85		15x85	
Anchor rod and internal threaded anchor FIS E without perforated sleeve												
Effective embedment depth h_{ef} [mm]	50	80	50	80	50	80	50	80	50	80	85	85
Max. installation torque $max T_{inst}$ [Nm]	8				10						8	10
General installation parameters												
Edge distance c_{min}	100											
Spacing	$s_{min II}$	100										
	$s_{cr II}$ [mm]	3 x h_{ef}										
	$s_{min \perp}$	100										
	$s_{cr \perp}$	3 x h_{ef}										
Drilling method												
Hole drilling with rotary drill mode or hammer drilling with hard metal hammer drill												

Table C6.2: Group factors

Anchor rod	M8		M10		M12		M16		-		-	
Internal threaded anchor FIS E	-		-		-		-		M8		M10	M12
									11x85		15x85	
Group factors	$\alpha_{g,N} (s_{min II})$	[-]	1,67									
	$\alpha_{g,V} (s_{min II})$		1,26									
	$\alpha_{g,N} (s_{min \perp})$		1,67									
	$\alpha_{g,V} (s_{min \perp})$		2,0									

fischer injection system FIS V Zero for masonry

Performances

Solid calcium silicate (sand-lime) brick KS, NF, dimensions, installation parameters

Annex C 6

Appendix 27 / 38

Solid calcium silicate (sand-lime) brick KS, NF, EN 771-2:2015

Table C7.1: Characteristic resistance to pull-out failure or brick breakout failure of a single anchor under tension loading

Anchor rod	M8		M10		M12		M16		-		-	
Internal threaded anchor FIS E	-		-		-		-		M8		M10	M12
	-		-		-		-		11x85		15x85	
Tension resistance $N_{RK} = N_{RK,p} = N_{RK,b} = N_{RK,p,c} = N_{RK,b,c}$ [kN] depending on the mean compressive strength f_b ; Installation and use condition d/d (temperature range 24/40°C)												
Mean compressive strength f_b	Effective embedment depth h_{ef} [mm]											
	50	80	50	80	50	80	50	80	85	85		
12 N/mm ²	2,0	2,0	2,5	4,5	2,0	4,5	2,0	2,0	2,0			
16 N/mm ²	2,5	2,5	2,5	5,0	2,5	5,0	2,5	2,5	2,5			
20 N/mm ²	2,5	3,0	3,0	6,0	2,5	6,0	2,5	3,0	2,5			
Tension resistance $N_{RK} = N_{RK,p} = N_{RK,b} = N_{RK,p,c} = N_{RK,b,c}$ [kN] depending on the mean compressive strength f_b ; Installation and use condition d/d (temperature range 50/80°C and 72/120°C)												
Mean compressive strength f_b	Effective embedment depth h_{ef} [mm]											
	50	80	50	80	50	80	50	80	85	85		
12 N/mm ²	1,5	1,5	1,5	3,0	1,5	3,0	1,5	1,5	1,5			
16 N/mm ²	1,5	1,5	2,0	3,5	1,5	3,5	1,5	1,5	1,5			
20 N/mm ²	2,0	2,0	2,0	4,0	2,0	4,0	2,0	2,0	2,0			

Table C7.2: Characteristic resistance to local brick failure or brick edge failure of a single anchor under shear loading

Anchor rod	M8		M10		M12		M16		-		-	
Internal threaded anchor FIS E	-		-		-		-		M8		M10	M12
	-		-		-		-		11x85		15x85	
Shear resistance $V_{RK} = V_{RK,b} = V_{RK,c,II} = V_{RK,c,L}$ [kN] depending on the mean compressive strength f_b ; Installation and use condition d/d (temperature range 24/40°C, 50/80°C and 72/120°C)												
Mean compressive strength f_b	Effective embedment depth h_{ef} [mm]											
	50	80	50	80	50	80	50	80	85	85		
12 N/mm ²	3,5	3,5	4,5	4,5	3,5	4,0	3,5	4,0	3,5	3,5	3,5	
16 N/mm ²	4,0	4,0	5,0	5,0	4,0	4,5	4,0	4,5	4,0	4,0	4,0	
20 N/mm ²	4,5	4,5	6,0	6,0	4,5	5,0	4,5	5,0	4,5	4,5	4,5	

Factor for job site tests see annex C16 and displacements see annex C17

fischer injection system FIS V Zero for masonry

Performances

Solid calcium silicate (sand-lime) brick KS, NF, Characteristic resistance under tension and shear loading

Annex C 7

Appendix 28 / 38

Perforated calcium silicate (sand-lime) brick KSL, 3DF, EN 771-2:2015

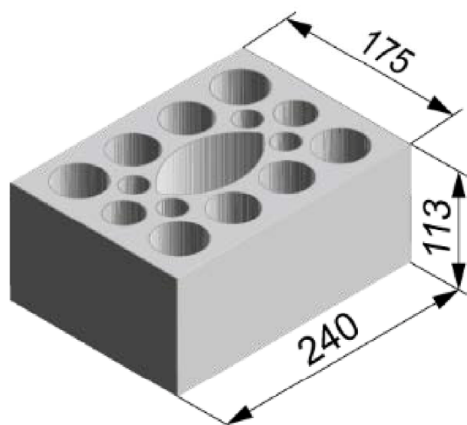

Perforated calcium silicate (sand-lime) brick KSL, 3DF, EN 771-2:2015			
Producer		e.g. KS Wemding	
Nominal dimensions [mm]		length L	width W
		240	175
Mean gross dry density ρ [kg/dm ³]		≥ 1,6	
Mean compressive strength [N/mm ²]		6 / 8 / 10 / 12 / 16	
Standard		EN 771-2:2015	

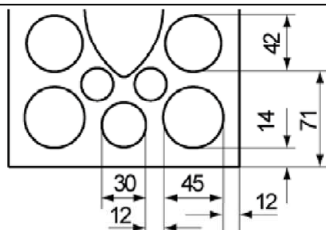

Dimensions see also Annex B 12

Table C8.1: Installation parameters (Pre-positioned installation with perforated sleeve FIS H K)

Anchor rod	M8	M8	-	M8	M10	M8	M10	-	M12	M16	M12	M16	
Internal threaded anchor FIS E	-	-	M8	-	-	M10	M12	-	-	-	-	-	
Perforated sleeve FIS H K	12x50	12x85	16x85		16x130		20x85		20x130				
Anchor rod and internal threaded anchor FIS E with perforated sleeve FIS H K													
Max. installation torque $\max T_{inst}$ [Nm]	8	8	8	8	10	8	10	10					
General installation parameters													
Edge distance C_{min}						100							
Spacing	$S_{min II}$						100						
	$S_{cr II}$ [mm]						240						
	$S_{min \perp}$						100						
	$S_{cr \perp}$						115						
Drilling method													
Hole drilling with rotary drill mode or hammer drilling with hard metal hammer drill													

Table C8.2: Group factors

Anchor rod	M8	M8	-	M8	M10	M8	M10	-	M12	M16	M12	M16	
Internal threaded anchor FIS E	-	-	M8	-	-	M10	M12	-	-	-	-	-	
Perforated sleeve FIS H K	12x50	12x85	16x85		16x130		20x85		20x130				
Group factors	$\alpha_{g,N} (S_{min II})$						1,14						
	$\alpha_{g,V} (S_{min II})$						1,51						
	$\alpha_{g,N} (S_{min \perp})$						1,14						
	$\alpha_{g,V} (S_{min \perp})$						1,54						

fischer injection system FIS V Zero for masonry

Performances

Perforated calcium silicate (sand-lime) brick KSL, 3DF, dimensions, installation parameters

Annex C 8

Appendix 29 / 38

Perforated calcium silicate (sand-lime) brick KSL, 3DF, EN 771-2:2015

Table C9.1: Installation parameters
(Push through installation with perforated sleeve FIS H K)

Anchor rod		M10	M12	M16
Perforated sleeve FIS H K		18x130/200		22x130/200
Anchor rod with perforated sleeve FIS H K				
Max. installation torque	$\max T_{inst}$ [Nm]			10
General installation parameters				
Edge distance	c_{min}			100
Spacing	$s_{min \parallel}$			100
	$s_{cr \parallel}$			240
	$s_{min \perp}$			100
	$s_{cr \perp}$			115
Drilling method				
Hole drilling with rotary drill mode or hammer drilling with hard metal hammer drill				

Table C9.2: Group factors

Anchor rod		M10	M12	M16
Perforated sleeve FIS H K		18x130/200		22x130/200
Group factors	$\alpha_{g,N} (s_{min \parallel})$			1,14
	$\alpha_{g,V} (s_{min \parallel})$			1,51
	$\alpha_{g,N} (s_{min \perp})$			1,14
	$\alpha_{g,V} (s_{min \perp})$			1,54

fischer injection system FIS V Zero for masonry

Performances

Perforated calcium silicate (sand-lime) brick KSL, 3DF, dimensions, installation parameters

Annex C 9

Appendix 30 / 38

Perforated calcium silicate (sand-lime) brick KSL, 3DF, EN 771-2:2015

Table C10.1: Characteristic resistance to pull-out failure or brick breakout failure of a single anchor under tension loading (Pre-positioned installation)

Anchor rod	M8	M8	-	M8	M10	M8	M10	-	M12	M16	M12	M16
Internal threaded anchor FIS E	-	-	M8	-	-	-	M10	M12	-	-	-	-
			11x85				15x85					
Perforated sleeve FIS H K	12x50	12x85	16x85		16x130		20x85			20x130		

Tension resistance $N_{RK} = N_{RK,p} = N_{RK,b} = N_{RK,p,c} = N_{RK,b,c}$ [kN] depending on the mean compressive strength f_b ; Installation and use condition d/d; (temperature range 24/40°C)

Mean compressive strength f_b								
6 N/mm ²	1,2		0,9		2,0		0,9	2,0
8 N/mm ²	1,5		1,2		2,5		1,2	2,5
10 N/mm ²	1,5		1,5		3,0		1,5	3,0
12 N/mm ²	2,0		1,5		3,5		1,5	3,5
16 N/mm ²	2,5		2,0		4,5		2,0	4,5

Tension resistance $N_{RK} = N_{RK,p} = N_{RK,b} = N_{RK,p,c} = N_{RK,b,c}$ [kN] depending on the mean compressive strength f_b ; Installation and use condition d/d; (temperature range 50/80°C and 72/120°C)

Mean compressive strength f_b								
6 N/mm ²	0,6		0,75		1,5		0,75	1,5
8 N/mm ²	0,75		0,9		2,0		0,9	2,0
10 N/mm ²	0,9		0,9		2,5		0,9	2,5
12 N/mm ²	0,9		1,2		2,5		1,2	2,5
16 N/mm ²	1,2		1,5		3,5		1,5	3,5

Table C10.2: Characteristic resistance to pull-out failure or brick breakout failure of a single anchor under tension loading (Push through installation)

Anchor rod	M10	M12	M16
Perforated sleeve FIS H K	18x130/200		22x130/200

Tension resistance $N_{RK} = N_{RK,p} = N_{RK,b} = N_{RK,p,c} = N_{RK,b,c}$ [kN] depending on the mean compressive strength f_b ; Installation and use condition d/d; (temperature range 24/40°C)

Mean compressive strength f_b				
6 N/mm ²			2,0	
8 N/mm ²			2,5	
10 N/mm ²			3,0	
12 N/mm ²			3,5	
16 N/mm ²			4,5	

Tension resistance $N_{RK} = N_{RK,p} = N_{RK,b} = N_{RK,p,c} = N_{RK,b,c}$ [kN] depending on the mean compressive strength f_b ; Installation and use condition d/d; (temperature range 50/80°C and 72/120°C)

Mean compressive strength f_b		
6 N/mm ²		1,5
8 N/mm ²		2,0
10 N/mm ²		2,5
12 N/mm ²		2,5
16 N/mm ²		3,5

Factor for job site tests see annex C16 and displacements see annex C17

fischer injection system FIS V Zero for masonry

Performances

Perforated calcium silicate (sand-lime) brick KSL, 3DF, Characteristic resistance under tension loading

Annex C 10

Appendix 31 / 38

Perforated calcium silicate (sand-lime) brick KSL, 3DF, EN 771-2:2015

Table C11.1: Characteristic resistance to local brick failure or brick edge failure of a single anchor under shear loading (Pre-positioned installation)

Anchor rod	M8	M8	-	M8	M10	M8	M10	-	M12	M16	M12	M16
Internal threaded anchor FIS E	-	-	M8	-	-	-	-	M10	M12	-	-	-
			11x85					15x85				
Perforated sleeve FIS H K	12x50	12x85	16x85		16x130		20x85			20x130		
Shear resistance $V_{Rk} = V_{Rk,b} = V_{Rk,c,II} = V_{Rk,c,I}$ [kN] depending on the mean compressive strength f_b; Installation and use condition d/d; (temperature range 24/40°C, 50/80°C and 72/120°C)												
Mean compressive strength f_b												
6 N/mm ²	1,5		2,0				3,0					
8 N/mm ²	2,0		2,5				3,5					
10 N/mm ²	2,5		3,0				4,5					
12 N/mm ²	2,5		3,5				5,0					
16 N/mm ²	3,5		4,0				6,5					

Table C11.2: Characteristic resistance to local brick failure or brick edge failure of a single anchor under shear loading (Push through installation)

Anchor rod	M10	M12	M16
Perforated sleeve FIS H K	18x130/200		22x130/200
Shear resistance $V_{Rk} = V_{Rk,b} = V_{Rk,c,II} = V_{Rk,c,I}$ [kN] depending on the mean compressive strength f_b; Installation and use condition d/d; (temperature range 24/40°C, 50/80°C and 72/120°C)			
Mean compressive strength f_b			
6 N/mm ²	2,0		3,0
8 N/mm ²	2,5		3,5
10 N/mm ²	3,0		4,5
12 N/mm ²	3,5		5,0
16 N/mm ²	4,0		6,5

Factor for job site tests see annex C16 and displacements see annex C17

fischer injection system FIS V Zero for masonry

Performances

Perforated calcium silicate (sand-lime) brick KSL, 3DF, Characteristic resistance under shear loading

Annex C 11

Appendix 32 / 38

Vertical perforated brick HLz, EN 771-1:2015

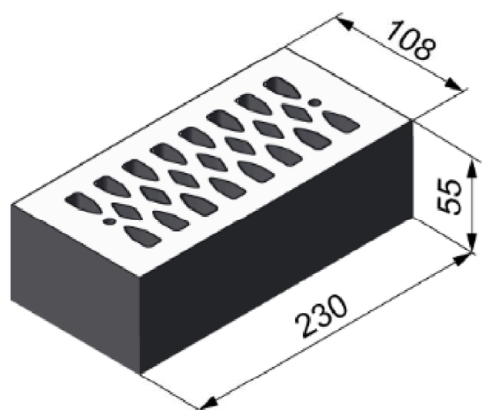

Vertical perforated brick HLz, EN 771-1:2015			
Producer	e.g. Wienerberger.		
Nominal dimensions [mm]	length L	width W	height H
	230	108	55
Mean gross dry density ρ [kg/dm ³]	≥ 1,6		
Mean compressive strength [N/mm ²]	8 / 10 / 12 / 16		
Standard	EN 771-1:2015		

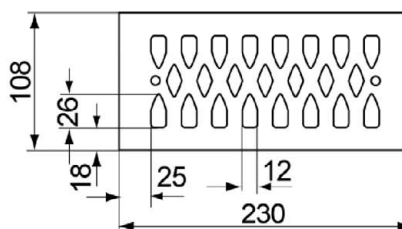

Dimensions see also Annex B 12

Table C12.1: Installation parameters

Anchor rod	M8	M8	-	M8	M10	M8	M10	-	M12	M16	M12	M16
Internal threaded anchor FIS E	-	-	M8	-	-	-	M10	M12	-	-	-	-
			11x85				15x85					
Perforated sleeve FIS H K	12x50	12x85	16x85		16x130		20x85			20x130		
Anchor rod and internal threaded anchor FIS E with perforated sleeve FIS H K												
Max. installation torque $\max T_{inst}$ [Nm]	5											
General installation parameters												
Edge distance c_{min}	100											
Spacing	$s_{min \parallel}$	100										
	$s_{cr \parallel}$	230										
	$s_{min \perp}$	60										
	$s_{cr \perp}$	60										
Drilling method												
Hole drilling with rotary drill mode or hammer drilling with hard metal hammer drill												

Table C12.2: Group factors

Anchor rod	M8	M8	-	M8	M10	M8	M10	-	M12	M16	M12	M16
Internal threaded anchor FIS E	-	-	M8	-	-	-	M10	M12	-	-	-	-
			11x85				15x85					
Perforated sleeve FIS H K	12x50	12x85	16x85		16x130		20x85			20x130		
Group factors	$\alpha_{g,N} (s_{min \parallel})$	1,65										
	$\alpha_{g,V} (s_{min \parallel})$	1,64										
	$\alpha_{g,N} (s_{min \perp})$	1,65										
	$\alpha_{g,V} (s_{min \perp})$	2,00										

fischer injection system FIS V Zero for masonry

Performances

Vertical perforated brick HLz, dimensions, installation parameters

Annex C 12

Appendix 33 / 38

Vertical perforated brick HLz, EN 771-1:2015

Table C13.1: Characteristic resistance to pull-out failure or brick breakout failure of a single anchor under tension loading

Anchor rod	M8	M8	-	M8	M10	M8	M10	-	M12	M16	M12	M16
Internal threaded anchor FIS E	-	-	M8	-	-	-	-	M10	-	-	-	-
			11x85					M12				
Perforated sleeve FIS H K	12x50	12x85	16x85		16x130		20x85			20x130		

Tension resistance $N_{RK} = N_{RK,p} = N_{RK,b} = N_{RK,p,c} = N_{RK,b,c}$ [kN] depending on the mean compressive strength f_b ; Installation and use condition d/d; (temperature range 24/40°C)

Mean compressive strength f_b												
8 N/mm ²	1,2	1,5	1,5		2,5		1,5			2,5		
10 N/mm ²	1,2	2,0	2,0		2,5		2,0			2,5		
12 N/mm ²	1,5	2,0	2,0		3,0		2,0			3,0		
16 N/mm ²	1,5	2,5	2,5		3,5		2,5			3,5		

Tension resistance $N_{RK} = N_{RK,p} = N_{RK,b} = N_{RK,p,c} = N_{RK,b,c}$ [kN] depending on the mean compressive strength f_b ; Installation and use condition d/d; (temperature range 50/80°C and 72/120°C)

Mean compressive strength f_b												
8 N/mm ²	0,6	1,2	1,2		1,5		1,2			1,5		
10 N/mm ²	0,75	1,2	1,2		2,0		1,2			2,0		
12 N/mm ²	0,75	1,5	1,5		2,0		1,5			2,0		
16 N/mm ²	0,9	1,5	1,5		2,5		1,5			2,5		

Table C13.2: Characteristic resistance to local brick failure or brick edge failure of a single anchor under shear loading

Anchor rod	M8	M8	-	M8	M10	M8	M10	-	M12	M16	M12	M16
Internal threaded anchor FIS E	-	-	M8	-	-	-	-	M10	-	-	-	-
			11x85					M12				
Perforated sleeve FIS H K	12x50	12x85	16x85		16x130		20x85			20x130		

Shear resistance $V_{RK} = V_{RK,b} = V_{RK,c,II} = V_{RK,c,L}$ [kN] depending on the mean compressive strength f_b ; Installation and use condition d/d; (temperature range 24/40°C, 50/80°C and 72/120°C)

Mean compressive strength f_b												
8 N/mm ²	2,0	3,5	2,5		3,5		2,5			3,5		
10 N/mm ²	2,0	4,0	3,0		4,0		3,0			4,0		
12 N/mm ²	2,0	4,0	3,0		4,5		3,0			4,5		
16 N/mm ²	2,5	5,0	3,5		5,0		3,5			5,0		

Factor for job site tests see annex C16 and displacements see annex C17

fischer injection system FIS V Zero for masonry

Performances

Vertical perforated brick HLz, Characteristic resistance under tension and shear loading

Annex C 13

Appendix 34 / 38

Lightweight aggregate concrete hollow block Hbl , EN 771-3:2015

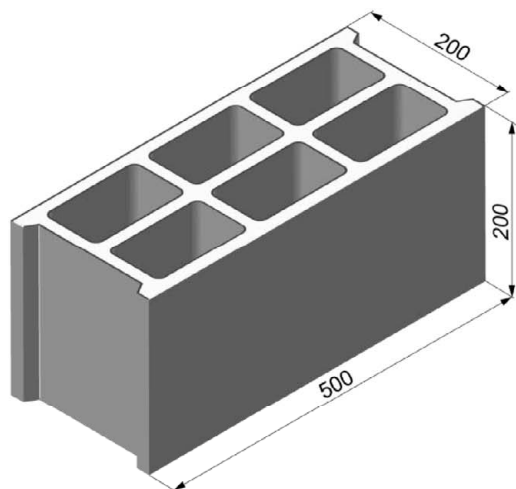

Lightweight aggregate concrete hollow block Hbl, EN 771-3:2015			
Producer		e.g. Sepa	
Nominal dimensions [mm]	length L	width W	height H
	500	200	200
Mean gross dry density ρ [kg/dm ³]	≥ 1,0		
Mean compressive strength [N/mm ²]	2 / 4		
Standard	EN 771-1:2015		

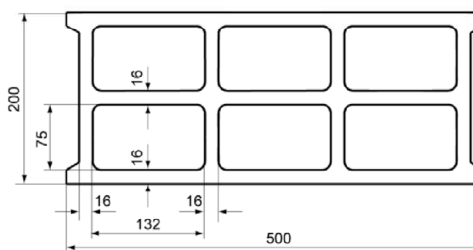

Dimensions see also Annex B 12

Table C14.1: Installation parameters

Anchor rod	-	M8	M10	M8	M10	M10	M12	-	M12	M16	M12	M16
Internal threaded anchor FIS E	M8							M10	M12			
	11x85	-	-	-	-	-	-	15x85	-	-	-	-
Perforated sleeve FIS H K	16x85		16x130		18x130/200		20x85			20x130		
Anchor rod and internal threaded anchor FIS E with perforated sleeve FIS H K												
Max. installation torque max T _{inst} [Nm]	2											
General installation parameters												
Edge distance C _{min}	100											
Spacing	S _{min}	100										
	S _{scr}	500										
	S _{min} ⊥	100										
	S _{scr} ⊥	200										
Drilling method												
Hole drilling with rotary drill mode or hammer drilling with hard metal hammer drill												

Table C14.2: Group factors

Anchor rod	-	M8	M10	M8	M10	M10	M12	-	M12	M16	M12	M16
Internal threaded anchor FIS E	M8							M10	M12			
	11x85	-	-	-	-	-	-	15x85	-	-	-	-
Perforated sleeve FIS H K	16x85		16x130		18x130/200		20x85			20x130		
Group factors	$\alpha_{g,N}$ (S _{min})	2,00										
	$\alpha_{g,V}$ (S _{min})	1,28										
	$\alpha_{g,N}$ (S _{min} ⊥)	1,40										
	$\alpha_{g,V}$ (S _{min} ⊥)	2,00										

fischer injection system FIS V Zero for masonry

Performances

Lightweight aggregate concrete hollow block Hbl, dimensions, installation parameters

Annex C 14

Lightweight aggregate concrete hollow block Hbl, EN 771-3:2015

Table C15.1: Characteristic resistance to pull-out failure or brick breakout failure of a single anchor under tension loading

Anchor rod	-	M8	M10	M8	M10	M10	M12	-	M12	M16	M12	M16
Internal threaded anchor FIS E	M8	-	-	-	-	-	-	M10	M12	-	-	-
	11x85							15x85				
Perforated sleeve FIS H K	16x85			16x130		18x130/200		20x85			20x130	

Tension resistance $N_{RK} = N_{RK,p} = N_{RK,b} = N_{RK,p,c} = N_{RK,b,c}$ [kN] depending on the mean compressive strength f_b ; Installation and use condition d/d; (temperature range 24/40°C)

Mean compressive strength f_b		
2 N/mm ²	0,4	0,6
4 N/mm ²	0,5	0,75

Tension resistance $N_{RK} = N_{RK,p} = N_{RK,b} = N_{RK,p,c} = N_{RK,b,c}$ [kN] depending on the mean compressive strength f_b ; Installation and use condition d/d; (temperature range 50/80°C and 72/120°C)

Mean compressive strength f_b		
2 N/mm ²	0,3	0,5
4 N/mm ²	0,4	0,6

Table C15.2: Characteristic resistance to local brick failure or brick edge failure of a single anchor under shear loading

Anchor rod	-	M8	M10	M8	M10	M10	M12	-	M12	M16	M12	M16
Internal threaded anchor FIS E	M8	-	-	-	-	-	-	M10	M12	-	-	-
	11x85							15x85				
Perforated sleeve FIS H K	16x85			16x130		18x130/200		20x85			20x130	

Shear resistance $V_{RK} = V_{RK,b} = V_{RK,c,||} = V_{RK,c,\perp}$ [kN] depending on the mean compressive strength f_b ; Installation and use condition d/d; (temperature range 24/40°C, 50/80°C and 72/120°C)

Mean compressive strength f_b		
2 N/mm ²	1,5	
4 N/mm ²	2,0	

Factor for job site tests see annex C16 and displacements see annex C17

fischer injection system FIS V Zero for masonry

Performances

Lightweight aggregate concrete hollow block Hbl
Characteristic resistance under tension and shear loading

Annex C 15

Appendix 36 / 38

β-factors for job site tests

Table C16.1: β-factors for job site tests

Installation and use conditions	d/d		
	24/40	50/80	72/120
temperature range [°C]			
M8	0,81	0,47	0,45
M10	0,62	0,49	0,45
M12 / FIS E 11x85	0,62	0,49	0,52
M16 / FIS E 15x85	0,56	0,45	0,59

fischer injection system FIS V Zero for masonry

Performances
β-factors for job site tests

Annex C 16

Appendix 37 / 38

Table C17.1: Displacements

Material	Size	Effective embedment depth [mm]	N [kN]	δN_0 [mm]	δN_∞ [mm]	V [kN]	δV_0 [mm]	δV_∞ [mm]
Solid brick acc. to C4-C5	M8	50	0,57	0,00	0,00	0,71	0,08	0,12
		80	1,00	0,00	0,00	1,71	0,32	0,48
	M10	50	0,57	0,00	0,00	0,71	0,18	0,27
		80	1,00	0,01	0,02	1,71	0,50	0,75
	M12	50	1,29	0,03	0,06	0,71	0,05	0,08
		80	1,00	0,01	0,02	1,71	0,75	1,13
	M16	50	1,29	0,03	0,06	0,71	0,35	0,53
		80	1,71	0,04	0,08	1,71	0,20	0,30
Solid calcium silicate (sand-lime) brick acc. to C6-C7	M8	50	0,86	0,03	0,06	1,43	0,32	0,48
		80	0,86	0,00	0,00	1,43		
	M10	50	0,86	0,00	0,00	1,43	0,34	0,51
		80	1,71	0,02	0,04	1,43		
	M12	50	0,86	0,03	0,06	1,43	0,12	0,18
		80	1,71	0,04	0,08	1,43	0,32	0,48
	M16	50	0,86	0,03	0,06	1,43	0,57	0,86
		80	1,14	0,02	0,04	1,43	0,20	0,03
Perforated calcium silicate (sand-lime) brick acc. to C8-C11	M8	12x50	0,71	0,01	0,02	1,00	0,16	0,24
		12x85						
	M8	16x85	0,57	0,02	0,04	1,14	0,57	0,86
	M10	16x130	1,29	0,06	0,12	1,14	1,03	1,55
	M12	20x85	0,57	0,03	0,06	1,86	1,15	1,73
	M16	20x130	1,29	0,04	0,08	1,86	1,24	1,86
Perforated brick Hz acc. to C12-C13	M8	12x50	0,43	0,00	0,00	0,71	0,25	0,38
		12x85	0,71	0,00	0,00	1,43	0,61	0,92
	M8	16x85	0,71	0,03	0,06	1,00	0,36	0,54
	M10	16x130	1,00	0,02	0,04	1,43	0,30	0,45
	M12	20x85	0,71	0,00	0,00	1,00	0,22	0,33
	M16	20x130	1,00	0,04	0,08	1,43	0,17	0,26
Lightweight aggregate concrete hollow block Hbl acc. to C14-C15	M8	16x85	0,14	0,03	0,06	0,57	1,54	2,31
	M10	16x130	0,14	0,02	0,04	0,57	1,01	1,52
	M12	20x85	0,14	0,06	0,12	0,57	1,31	1,97
	M16	20x130	0,21	0,04	0,08	0,57	0,82	1,23

fischer injection system FIS V Zero for masonry

Performances
displacements**Annex C 17**

Appendix 38 / 38