

TELJESÍTMÉNYNYILATKOZAT

DoP 0269

fischer FDZ plafonszeg-hez (Mechanikus rögzítőelem betonba történő felhasználásra)

HU

1. A terméktípus egyedi azonosító kódja: DoP 0269
2. Felhasználás célja(i): Utólag beépített rögzítőelem redundáns, nem-teherhordó szerkezeti rendszerek betonban történő felhasználásra, ld. a Mellékletet, különösen ezt a mellékleteket B1 - B2.
3. Gyártó: fischerwerke GmbH & Co. KG, Klaus-Fischer-Str. 1, 72178 Waldachtal, Németország
4. A meghatalmazott képviselő: -
5. Az AVCP-rendszer(ek): 2+
6. Az európai értékelési dokumentum: ETAG 001, Part 6, April 2013, EAD használatos
Európai műszaki értékelés: ETA-17/0737; 2018-01-30
A műszaki értékelést végző szerv: DIBt- Deutsches Institut für Bautechnik
Bejelentett szerv(ek): 2873 TU Darmstadt
7. A nyilatkozatban szereplő teljesítmény(ek):
Biztonsági használat (BWR 4)
Karakterisztikus ellenállás húzásra (statikus és kvázi-statisz terhelések):
Ellenállás acél szakadás tönkremenetel esetén: NP
Ellenállás kihúzóadás tönkremenetel esetén: NP
Ellenállás beton szakadóképzés tönkremenetel esetén: NP
Ellenállóképesség: Melléklet C1
Min. perem- és tengelytávolság: Mellékletek B2, C1
Peremtávolság hasadási tönkremenetel megelőzésére: NP
- Karakterisztikus ellenállás nyírásra (statikus és kvázi-statisz terhelések):**
Ellenállás acél szakadás tönkremenetel esetén (nyírás): Melléklet C1 $V_{Rk,s}=NP$; $k_{\gamma}=NP$
Ellenállás pry-out tönkremenetel esetén: NP
Ellenállás beton kitérés tönkremenetel esetén (nyírás): NP
- Karakterisztikus ellenállás minden terhelési irányra és tönkremeneteli módokra az egyszerűbb tervezésért:**
Karakterisztikus ellenállás: Melléklet C1
- Tartósság:**
Tartósság: Melléklet B1
- Biztonság tűz esetén (BWR 2)**
Tűzzel szembeni viselkedés: Osztály (A1)
- Tűzállóság:**
Tűzállóság acél tönkremenetelnél (húzásra) NP
Tűzállóság kihúzóadás tönkremenetel esetén (húzásra) NP
Tűzállóság acél tönkremenetel esetén (nyírásra) NP
Tűzállóság minden terhelési irányra és tönkremeneteli módokra: Melléklet C1
8. Megfelelő műszaki dokumentáció és/vagy egyedi műszaki dokumentáció: -

A fent azonosított termék teljesítménye megfelel a bejelentett teljesítmény(ek)nek. A 305/2011/EU rendeletnek megfelelően e teljesítménynyilatkozat kiadásáért kizárólag a fent meghatározott gyártó a felelős

A gyártó nevében és részéről aláíró személy:



Dr.-Ing. Oliver Geibig, Üzleti egységek és Mémországért felelős vezérigazgató
Tumlingen, 2021-01-11



Jürgen Grün, Vegyi és Minőségért felelős vezérigazgató

Ez a Teljesítmény nyilatkozat különböző nyelveken elkészült. Vítás értelmezés esetén az angol verzió az irányadó.

A melléklet a (nyelvsemleges formában megadott) törvényi előírásokon túl önkéntesen megadott, kiegészítő információkat is tartalmaz angolul.

Specific Part

1 Technical description of the product

The Fischer Ceiling Anchor FDZ is an anchor made of galvanized steel which is placed into a drilled hole and anchored by deformation-controlled expansion.

The product description is given in Annex A.

2 Specification of the intended use in accordance with the applicable European Assessment Document

The performances given in Section 3 are only valid if the anchor is used in compliance with the specifications and conditions given in Annex B.

The verifications and assessment methods on which this European Technical Assessment is based lead to the assumption of a working life of the anchor of at least 50 years. The indications given on the working life cannot be interpreted as a guarantee given by the producer, but are to be regarded only as a means for choosing the right products in relation to the expected economically reasonable working life of the works.

3 Performance of the product and references to the methods used for its assessment

3.1 Mechanical resistance and stability (BWR 1)

The essential characteristics regarding mechanical resistance and stability are included under the Basic Works Requirement Safety in use.

3.2 Safety in case of fire (BWR 2)

| Essential characteristic | Performance |
|--------------------------|---|
| Reaction to fire | Anchorage satisfies requirements for Class A1 |
| Resistance to fire | See Annex C 1 |

3.3 Safety in use (BWR 4)

| Essential characteristic | Performance |
|---------------------------------------|---------------|
| Characteristic resistance in concrete | See Annex C 1 |

4 Assessment and verification of constancy of performance (AVCP) system applied, with reference to its legal base

In accordance with guideline for European technical approval ETAG 001, April 2013 used as European Assessment Document (EAD) according to Article 66 Paragraph 3 of Regulation (EU) No 305/2011 the applicable European legal act is: [97/161/EC].

The system to be applied is: 2+

Product installation conditions, product marking and product dimensions

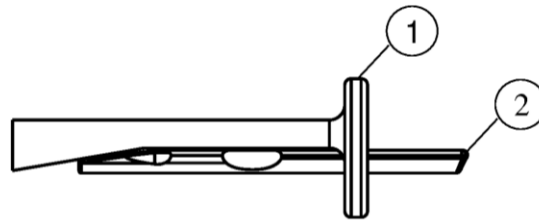

- ① Shaft
- ② Pin

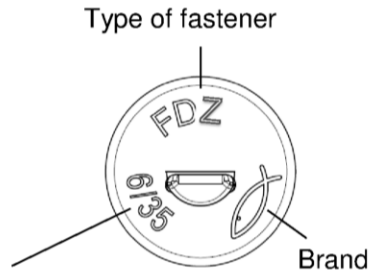
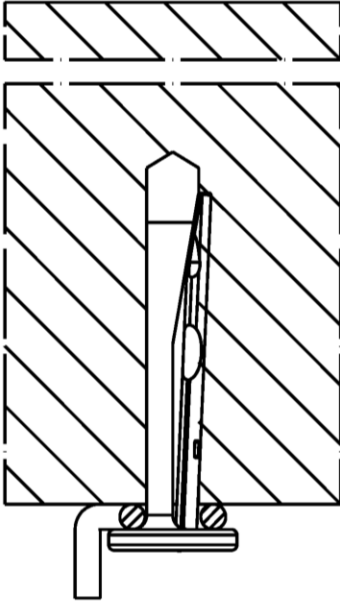

Nominal diameter / max. thickness of the fixture;
Additional marking "K" for $h_{ef} = 25$ mm

Table A1.1: Dimensions

| Size | FDZ | | | |
|---|-------|------|--------|------|
| | 6/5 K | 6/5 | 6/35 K | 6/35 |
| Length of the $\frac{\text{pin}}{\text{shaft}}$ L_1 | 36 | 43 | 66 | 73 |
| L_2 [mm] | 30,5 | 37,5 | 60,5 | 67,5 |
| Diameter of the head $D \geq$ | 13 | | | |

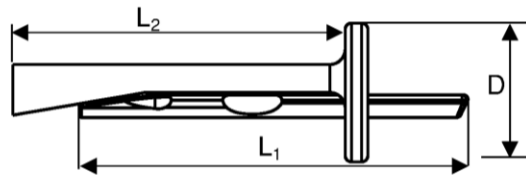

(Fig. not to scale)

fischer Ceiling Anchor FDZ

Product description

Product installation conditions, product marking and product dimensions

Annex A 1

Appendix 2 / 5

Specifications of intended use

Anchorage subject to:

| | |
|---|-------|
| Size | FDZ 6 |
| Static and quasi-static loads | ✓ |
| Use for multiple fixture of non-structural applications according to ETAG 001, Part 6 | |
| Fire exposure | |

Base materials:

- Reinforced and unreinforced normal weight concrete according to EN 206-1:2000
- Strength classes C12/15 to C50/60 according to EN 206-1:2000
- Cracked and non-cracked concrete

Use conditions (Environmental conditions):

- Anchorage subject to dry internal conditions

Design:

- Anchorages are designed under the responsibility of an engineer experienced in anchorages and concrete work
- Verifiable calculation notes and drawings have to be prepared taking account of the loads to be anchored. The position of the anchor is indicated on the design drawings (e.g. position of the anchor relative to reinforcement or to supports, etc.).
- Anchorages under static or quasi-static actions have to be designed for Design Method C in accordance with:
 - ETAG 001, Annex C, Design Method C, Edition August 2010
 - CEN/TS 1992-4:2009
- Anchorages under fire exposure have to be designed in accordance with
 - EOTA Technical Report TR 020, Edition May 2004
 - CEN/TS 1992-4:2009, Annex D (it must be ensured that local spalling of the concrete cover does not occur)

fischer Ceiling Anchor FDZ

Intended use
Specifications

Annex B 1

Appendix 3 / 5

Table B2.1: Installation parameters

| Size | | | FDZ | | | |
|---|-----------------------|--------|-------|-----|--------|------|
| | | | 6/5 K | 6/5 | 6/35 K | 6/35 |
| Thickness of the fixture | t_{fix} | \leq | 5 | | 35 | |
| Nominal drill hole diameter | d_0 | | 6 | | | |
| Diameter of clearance hole in the fixture | d_f | \leq | 7 | | | |
| Maximum bit diameter | $d_{cut,max}$ | | 6,40 | | | |
| Effective embedment depth | h_{ef} | [mm] | 25 | 32 | 25 | 32 |
| Depth of drill hole to deepest point | with hole cleaning | h_1 | 30 | 37 | 30 | 37 |
| | without hole cleaning | | 35 | 42 | 35 | 42 |
| Minimum thickness of concrete member | h_{min} | | 80 | | | |

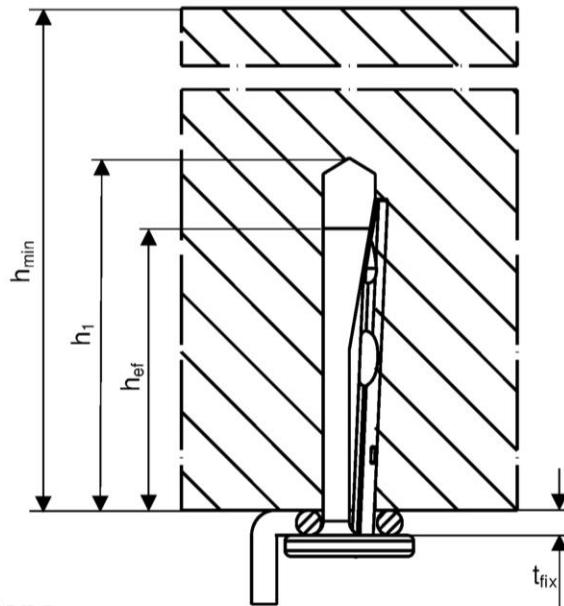

Installation instructions

- Hammer or hollow drilling only
- Anchor installation carried out by appropriately qualified personnel and under the supervision of the person responsible for technical matters of the site
- Positioning of the drill holes without damaging the reinforcement
- In case of aborted hole: New drilling at a minimum distance twice the depth of aborted hole away of or smaller distance if the aborted hole is filled with high strength mortar and if under shear or oblique tension load it is not in the direction of the load application

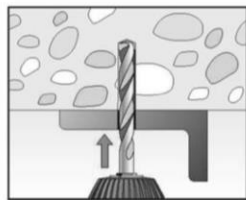

1: Drill the hole

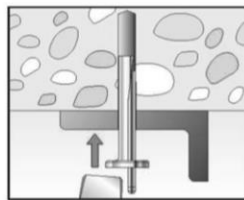

2: Set the fastener

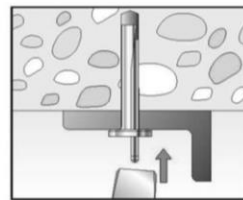

3: Set the pin, until flush to the surface

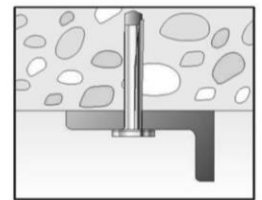

4: Installed fastener

(Fig. not to scale)

fischer Ceiling Anchor FDZ

Intended use

Installation parameters and installation instructions

Annex B 2

Appendix 4 / 5

| Table C1.1: Characteristic resistance | | | |
|---|---------------------------|----------------------|-----|
| Size | | FDZ 6 | |
| For all load directions and for all failures modes | | | |
| Effective embedment depth | h_{ef} [mm] | 25 | 32 |
| Characteristic resistance in cracked and non-cracked concrete | C12/15 | 1,0 | 1,5 |
| | C20/25 to C50/60 | 1,5 | 2,0 |
| Characteristic edge distance | $c_{cr,N} = c_{min}$ [mm] | 70 | 60 |
| | spacing | $s_{cr,N} = s_{min}$ | 60 |
| Partial safety factor | $\gamma_M^{2)}$ [-] | 1,5 | |
| Shear load with lever arm | | | |
| Characteristic bending resistance | $M_{Rk,s}^0$ [Nm] | 4,4 | |
| Partial safety factor for steel failure | $\gamma_{Ms}^1)$ [-] | 1,25 | |
| ¹⁾ In absence of other national regulations ²⁾ The installation safety factor $\gamma_2 = \gamma_{inst} = 1,0$ is included | | | |

Table C1.2: Characteristic resistance under fire exposure for all effective embedment depths

| Size | | FDZ 6 | |
|---|---------------------------|----------------------|------|
| Steel failure for tension and shear load | | | |
| R30 | Characteristic resistance | $F_{Rk,s,fi30}$ | 1,00 |
| R60 | | $F_{Rk,s,fi60}$ | 0,50 |
| R90 | | $F_{Rk,s,fi90}$ [kN] | 0,34 |
| R120 | | $F_{Rk,s,fi120}$ | 0,26 |
| R180 | | $F_{Rk,s,fi180}$ | 0,17 |
| Spacing and edge distance | | | |
| R30 – R120 | | $s_{cr,fi}$ [mm] | 200 |
| | | $c_{cr,fi}$ | 150 |

For fire exposure from more than one side $c_{min} \geq 300$ mm

| | |
|---|------------------|
| fischer Ceiling Anchor FDZ | Annex C 1 |
| Performances | |
| Characteristic resistance and characteristic resistance under fire exposure | Appendix 5 / 5 |