

## DÉCLARATION DES PERFORMANCES

### DoP 0328

pour cheville à frapper fischer Zykon FZEA II (fixation mécanique pour utilisation dans le béton)

FR

1. Code d'identification unique du type de produit: **DoP 0328**
2. Usage(s) prévu(s): **Fixation dans du béton fissuré ou non fissuré, voir annexes, en particulier les annexes B1 - B3.**
3. Fabricant: **fischerwerke GmbH & Co. KG, Klaus-Fischer-Str. 1, 72178 Waldachtal, Allemagne**
4. Mandataire: **-**
5. Système(s) d'évaluation et de vérification de la constance des performances: **1**
6. Document d'évaluation européen: **EAD 330232-01-0601, Edition 05/2021**  
Evaluation Technique Européenne: **ETA-06/0271; 2023-03-23**  
Organisme d'évaluation technique: **DIBt- Deutsches Institut für Bautechnik**  
Organisme(s) notifié(s): **2873 TU Darmstadt**

### 7. Performance(s) déclarée(s):

#### **Résistance mécanique et stabilité (BWR 1)**

##### **Résistance caractéristique à la charge de traction (charge statique et quasi-statique) Méthode A:**

Résistance à la rupture de l'acier: Annexe C1

Résistance à l'extraction glissement: Annexe C1

Résistance à la rupture du cône béton: Annexe C1

Robustesse: Annexes C1, C2

Distance au bord et entraxe mini.: Annexes B2, C1

Distance au bord pour éviter la rupture par fendage sous charge: Annexe C1

##### **Résistance caractéristique à la charge de cisaillement (charge statique et quasi-statique), Méthode A:**

Résistance à la rupture de l'acier (charge de cisaillement) : Annexe C2

Résistance à la rupture par effet de levier : Annexe C2

##### **Résistance caractéristique pour un dimensionnement simplifié:**

Méthode B: NPD

Méthode C: NPD

##### **Déplacements:**

Déplacements sous charge statique et quasi-statique: Annexe C4

##### **Résistance caractéristique et déplacements pour les catégories de performance sismique C1 et C2:**

Résistance à la charge de traction, déplacements, catégorie C1: NPD

Résistance à la charge de traction, déplacements, catégorie C2: NPD

Résistance à la charge de cisaillement, déplacements, catégorie C1: NPD

Résistance à la charge de cisaillement, déplacements, catégorie C2: NPD

Facteur espace annulaire : NPD

#### **Sécurité en cas d'incendie (BWR 2)**

Réaction au feu: Classe (A1)

##### **Résistance au feu:**

Résistance en cas d'incendie, rupture de l'acier (charge de traction) : Annexe C3

Résistance en cas d'incendie, extraction glissement (charge de traction) : Annexe C3

Résistance en cas d'incendie, rupture de l'acier (charge de cisaillement) : Annexe C3

#### **Durabilité:**

Durabilité: Annexes A2, B1

8. Documentation technique appropriée et/ou documentation technique spécifique: **-**



Les performances du produit identifié ci-dessus sont conformes aux performances déclarées. Conformément au règlement (UE) no 305/2011, la présente déclaration des performances est établie sous la seule responsabilité du fabricant mentionné ci-dessus.

Signé pour le fabricant et en son nom par:

Dr.-Ing. Oliver Geibig, Directeur Général Business Units & Ingénierie  
Tumlingen, 2023-03-31

Jürgen Grün, Directeur Général Chimie & Qualité

Cette DoP a été préparée en plusieurs langues. En cas de différend relatif à l'interprétation, la version anglaise prévaudra.

L'annexe comprend des informations volontaires et complémentaires en langue anglaise dépassant les exigences légales (spécifiées de manière neutre).

## Specific Part

### 1 Technical description of the product

The fischer Zykon-Hammerset anchor FZEA II is an anchor made of galvanised or stainless or high corrosion resistant steel which is placed in an undercut hole and anchored by mechanical interlock with displacement-controlled installation.

The product description is given in Annex A.

### 2 Specification of the intended use in accordance with the applicable European Assessment Document

The performances given in Section 3 are only valid if the fastener is used in compliance with the specifications and conditions given in Annex B.

The verifications and assessment methods on which this European Technical Assessment is based lead to the assumption of a working life of the fastener of at least 50 years. The indications given on the working life cannot be interpreted as a guarantee given by the producer, but are to be regarded only as a means for choosing the right products in relation to the expected economically reasonable working life of the works.

### 3 Performance of the product and references to the methods used for its assessment

#### 3.1 Mechanical resistance and stability (BWR 1)

Essential characteristic	Performance
Characteristic resistance to tension load (static and quasi static loading) Method A	See Annex B2 and C1
Characteristic resistance to shear load (static and quasi static loading)	See Annex C2
Displacements	See Annex C4
Characteristic resistance and displacements for seismic performance categories C1 and C2	No performance assessed

#### 3.2 Safety in case of fire (BWR 2)

Essential characteristic	Performance
Reaction to fire	Class A1
Resistance to fire	See Annex C3

#### 3.3 Aspects of durability

Essential characteristic	Performance
Durability	See Annex B1

**4 Assessment and verification of constancy of performance (AVCP) system applied, with reference to its legal base**

In accordance with the European Assessment Document EAD 330232-01-0601 the applicable European legal act is: [96/582/EC].

The system to be applied is: 1

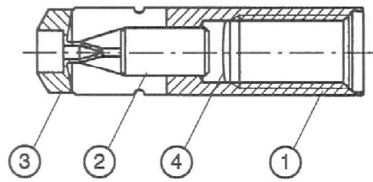

- ① Expansion sleeve
- ② Expansion pin
- ③ Plastic cap
- ④ Safety disk

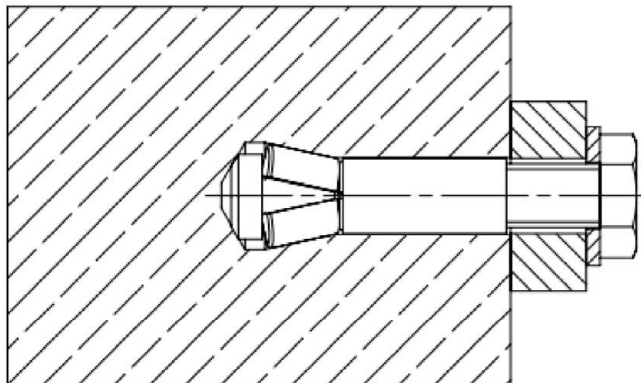

*(Fig. not to scale)*

**fischer Zykon-Hammerset anchor FZEA II**

**Product description**  
Installed condition

**Annex A 1**

Appendix 3 / 11

Marking e.g.:



FZEA II 12x40 (galvanised steel)  
 FZEA II 12x40 R (stainless steel)  
 FZEA II 12x40 HCR (high corrosion resistant steel)

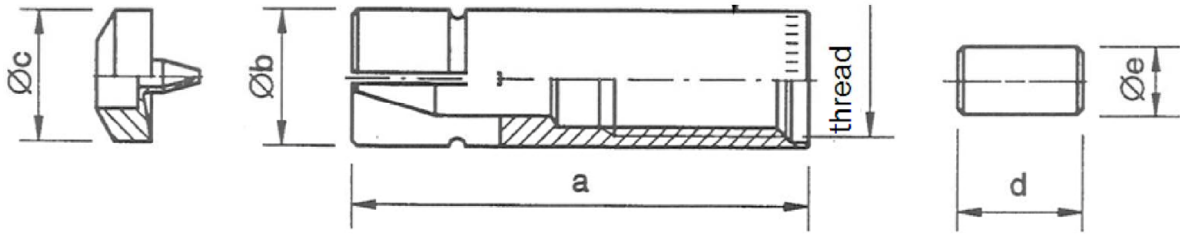

**Table A2.1: Dimensions [mm]**

Anchor type	thread	a [mm]	Øb [mm]	Øc [mm]	d [mm]	Øe [mm]
FZEA II 10 x 40 M8	M8	39	10	9,5	11	6,5
FZEA II 12 x 40 M10	M10		12	11,5		6,5
FZEA II 14 x 40 M12	M12		14	13,5		9,5

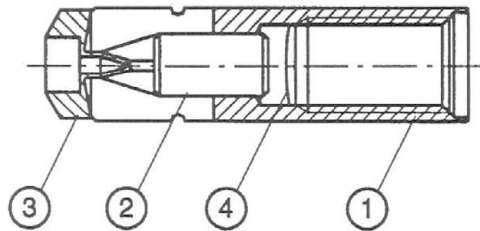

**Table A2.2: Materials**

Part	Designation	Material	Material	
		FZEA II	Corrosion resistance class acc. to EN 1993-1-4:2006+A1:2015 CRC III FZEA II R	CRC V FZEA II HCR
1	Expansion sleeve	Steel, EN 10277:2018 EN ISO 4042:2022 $\geq 5 \mu\text{m}$	Stainless steel, EN 10088:2014	High corrosion resistant steel EN 10088:2014
2	Expansion pin	Steel, EN 10277:2018 or EN 10263-1:2017 EN ISO 4042:2022 $\geq 5 \mu\text{m}$	Stainless steel, EN 10088:2014	High corrosion resistant steel EN 10088:2014
3	Plastic cap	Plastic		
4	Safety disk	Foil		
Requirements for the fastening screw / threaded rod <sup>1)</sup>		Steel, EN ISO 898-1:2013 EN ISO 4042:2022 $\geq 5 \mu\text{m}$  strength class $\geq 5.8$	Stainless steel EN ISO 3506-1:2010 1.4401, 1.4404, 1.4578, 1.4571, 1.4439, 1.4362 strength class $\geq 50$	High corrosion resistant steel EN ISO 3506-1:2020 1.4529, 1.4565  strength class $\geq 50$

<sup>1)</sup> The length of the fastening screw shall be determined depending on the thickness of the fixture  $t_{\text{fix}}$ , admissible tolerances, existing thread length (= maximum screwing depth) and minimum screwing depth (according to Table B2). Washers and screws or threaded rods with hexagon nuts are not included in the scope of delivery

(Fig. not to scale)

**fischer Zykon-Hammerset anchor FZEA II**

**Product description**  
 Anchor types and dimensions  
 Materials

**Annex A 2**

Appendix 4 / 11

## Specifications of intended use

### Anchorage subject to:

- Static and quasi-static loads
- Fire exposure

### Base materials:

- Compacted reinforced or unreinforced normal weight concrete without fibres (cracked and uncracked) of strength classes C20/25 to C50/60 according to EN 206:2013+A2:2021

### Use conditions (Environmental conditions):

- Structures subject to dry internal conditions: **FZEA II**
- For all other conditions according to EN 1993-1-4:2006+A1:2015 corresponding to corrosion resistance class:
  - **CRC III**            **FZEA II R**
  - **CRC V**              **FZEA II HCR**

### Design:

- Anchorages are designed under the responsibility of an engineer experienced in anchorages and concrete work.
- Verifiable calculation notes and drawings are prepared taking account of the loads to be anchored. The position of the anchor is indicated on the design drawings (e.g. position of the anchor relative to reinforcement or to supports, etc.)
- Design of fastenings according to EN 1992-4:2018 and EOTA Technical Report TR 055, Edition February 2018

### Installation:

- Anchor installation carried out by appropriately qualified personnel and under the supervision of the person responsible for technical matters of the site
- Correct installation is ensured when front face of sleeve is approximately 1 mm below the concrete surface and the control mark on the sleeve is visible as illustrated in Annex B2

**fischer Zykon-Hammerset anchor FZEA II**

**Intended Use**  
Specifications

**Annex B 1**

Appendix 5 / 11

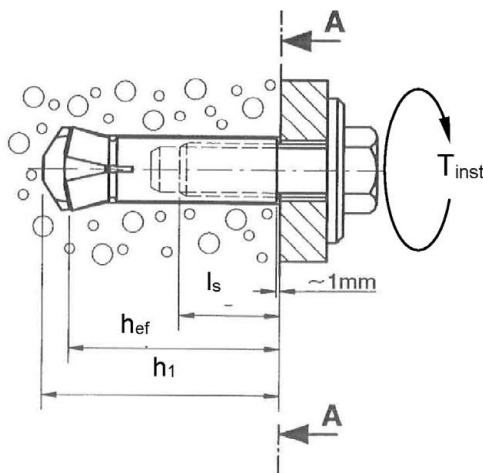
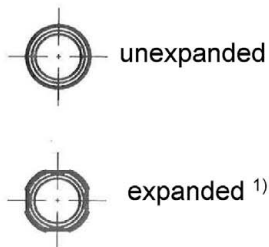

Description installation control  
plan view A-A



$h_{ef}$  = Effective anchorage depth  
 $l_s$  = Screw-in depth  
 $h_1$  = Drill hole depth  
 $T_{inst}$  = Max. installation torque

1) By setting the anchor with the machine setting tool stop the rotation, otherwise a round flange is formed instead of the notch

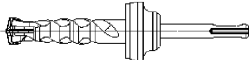
**Table B2.1: Installation tools**

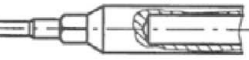
Anchor type	FZEA II 10x40 M8	FZEA II 12x40 M10	FZEA II 14x40 M12
Zykon-Universal drill 	FZUB 10x40	FZUB 12x40	FZUB 14x40
Zykon Impact thorn 	FZED 10 plus	FZED 12 plus	FZED 14 plus
Machine setting tool 	FZEM 10x40	FZEM 12x40	FZEM 14x40

**Table B2.2: Installation parameters**

Anchor type	Drill hole depth $h_1$ [mm]	Anchorage depth $h_{ef}$ [mm]	Fastening screw or threaded rod			
			Max. installation torque $T_{inst}$ [Nm]		Screw-in depth $l_s$ [mm]	
			FZEA II	FZEA II R FZEA II HCR	max	min
FZEA II 10 x 40 M8	43	40	≤ 10	≤ 15	17	11
FZEA II 12 x 40 M10	43	40	≤ 15	≤ 20	19	13
FZEA II 14 x 40 M12	43	40	≤ 20	≤ 40	21	15

**Table B2.3: Minimum thickness of concrete members, minimum spacing and minimum edge distance**

Anchor type and size		FZEA II 10x40 M8	FZEA II 12x40 M10	FZEA II 14x40 M12
Minimum thickness of concrete member	$h_{min}$	80	80	80
Minimum spacing	$s_{min}$	40	45	50
Minimum edge distance	$c_{min}$	40	45	50

(Fig. not to scale)

fischer Zykon-Hammerset anchor FZEA II

**Intended Use**

Installation tools, Installation and anchor parameters  
 Minimum thickness of concrete members, minimum spacing and minimum edge distance

**Annex B 2**

Appendix 6 / 11



## Installation instructions

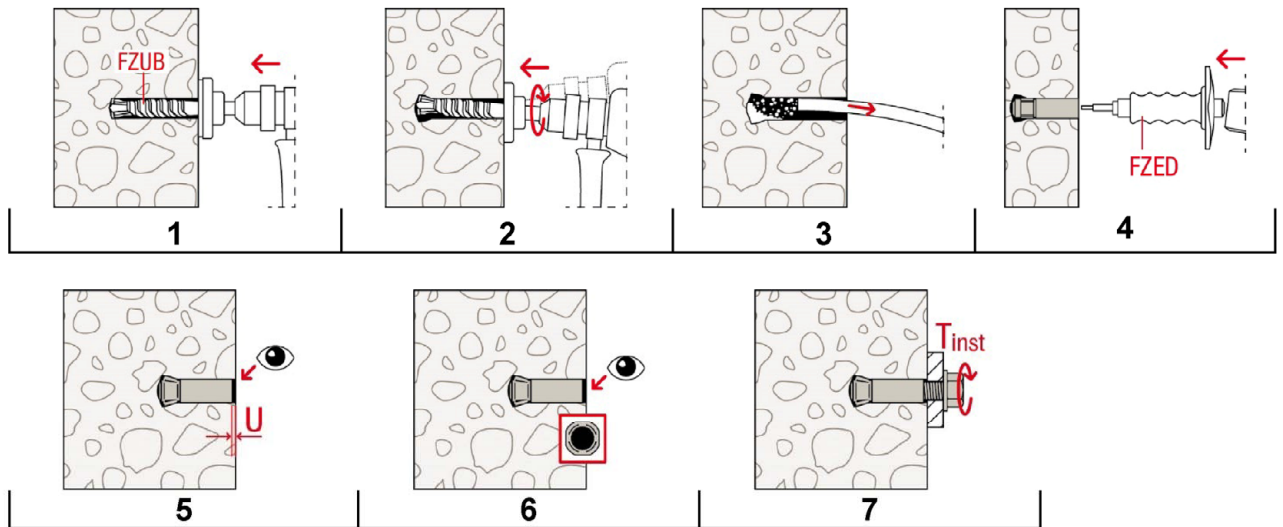

No.	Description
1	Drill a hole perpendicular ( $\pm 5^\circ$ ) to the surface of the anchor base with a hammer drill, using the corresponding Zykon universal drill bit FZUB. The required drill depth is reached once the FZUB depth stop meets the concrete.
2	Once the FZUB depth stop meets the concrete, create the drill hole undercut by making circular swiveling movements with the hammer drill while the hammer mechanism is engaged. Press the hammer drill firmly against the anchor base: 2-3 swiveling movements are sufficient
3	Clean bore hole
4	Drive in the pin with the setting tool FZED
5	Check if the sleeve is under the concrete surface ( $U \approx 1\text{mm}$ )
6	Check of the setting notch for correct installation
7	Apply $T_{\text{inst}}$

fischer Zykon-Hammerset anchor FZEA II

**Intended Use**  
Installation instructions

**Annex B 3**

Appendix 7 / 11

**Table C1.1:** Characteristic values of **tension** resistance under static and quasi-static action

Type of anchor			FZEA II 10x40 M8	FZEA II 12x40 M10	FZEA II 14x40 M12
<b>Steel failure – decisive values of sleeve and screw / threaded rod</b>					
Characteristic resistance <b>FZEA II</b> Strength class $\geq 5.8$ <sup>1)</sup>	$N_{Rk,s}$	[kN]	9,6	17,0	19,7
Partial factor	$\gamma_{Ms}$	[-]	1,5		
Characteristic resistance <b>FZEA II R, FZEA II HCR</b> Strength class 50 <sup>1)</sup>	$N_{Rk,s}$	[kN]	18,3	29,0	42,2
Partial factor	$\gamma_{Ms}$	[-]	2,86		
Characteristic resistance <b>FZEA II R, FZEA II HCR</b> Strength class $\geq 70$ <sup>1)</sup>	$N_{Rk,s}$	[kN]	12,2	21,6	25,0
Partial factor	$\gamma_{Ms}$	[-]	1,5		
<b>Pullout failure</b>					
Characteristic resistance in cracked concrete C20/25	$N_{Rk,p}$	[kN]	4,0	7,5	9,0
Characteristic resistance in uncracked concrete C20/25	$N_{Rk,p}$		9,0	9,0	9,0
Increasing factors for $N_{Rk,p}$ $N_{Rk,p} = \psi_c \cdot N_{Rk,p} (C20/25)$	$\psi_c$ [-]	C25/30	1,12		
		C30/37	1,22		
		C35/45	1,32		
		C40/50	1,41		
		C45/55	1,50		
		C50/60	1,58		
Installation safety factor	$\gamma_{inst}$	[-]	1,2		
<b>Concrete cone failure</b>					
Effective anchorage depth	$h_{ef}$	[mm]	40	40	40
Factor for uncracked concrete	$k_{ucr}$	[-]	11,0		
Factor for cracked concrete	$k_{cr}$		7,7		
Minimal member thickness	$h_{min}$	[mm]	80	80	80
Spacing	$s_{cr,N}$		120	120	120
Edge distance	$c_{cr,N}$		60	60	60
Spacing (splitting)	$s_{cr,sp}$		170	170	170
Edge distance (splitting)	$c_{cr,sp}$		85	85	85
Characteristic resistance to splitting	$N^0_{Rk,sp}$		[kN]	$\min \{N^0_{Rk,c}; N_{Rk,p}\}$ <sup>2)</sup>	

<sup>1)</sup> Strength class of the screw / threaded rod

<sup>2)</sup>  $N^0_{Rk,c}$  acc. to EN 1992-4:2018

**fischer Zykon-Hammerset anchor FZEA II**

**Performances**

Characteristic values of tension resistance

**Annex C 1**

Appendix 8 / 11

**Table C2.1:** Characteristic values of **shear** resistance under static and quasi-static action

Type of anchor		FZEA II 10x40 M8	FZEA II 12x40 M10	FZEA II 14x40 M12
<b>Steel failure without lever arm - decisive values of sleeve and screw / threaded rod</b>				
Characteristic resistance <b>FZEA II</b> Strength class $\geq 5.8$ <sup>1)</sup>	$V_{Rk,s}^0$ [kN]	8,3	13,6	19,1
Partial factor	$\gamma_{Ms}$ [-]	1,25		
Characteristic resistance <b>FZEA II R, FZEA II HCR</b> Strength class 50 <sup>1)</sup>	$V_{Rk,s}^0$ [kN]	9,2	14,5	21,1
Partial factor	$\gamma_{Ms}$ [-]	2,38		
Characteristic resistance <b>FZEA II R, FZEA II HCR</b> Strength class $\geq 70$ <sup>1)</sup>	$V_{Rk,s}^0$ [kN]	10,0	15,0	20,6
Partial factor	$\gamma_{Ms}$ [-]	1,25		
Factor for ductility	$k_7$ [-]	1,0		
<b>Steel failure with lever arm - decisive values of sleeve and screw / threaded rod</b>				
Characteristic resistance <b>FZEA II</b> Strength class $\geq 5.8$ <sup>1)</sup>	$M_{Rk,s}^0$ [Nm]	15,0	23,0	31,0
Partial factor	$\gamma_{Ms}$ [-]	1,25		
Characteristic resistance <b>FZEA II C, FZEA II HCR</b> <sup>1)</sup> Strength class 50 <sup>1)</sup>	$M_{Rk,s}^0$ [Nm]	18,7	37,4	65,5
Partial factor	$\gamma_{Ms}$ [-]	2,38		
Characteristic resistance <b>FZEA II C, FZEA II HCR</b> Strength class $\geq 70$ <sup>1)</sup>	$M_{Rk,s}^0$ [Nm]	19,0	29,0	39,0
Partial factor	$\gamma_{Ms}$ [-]	1,25		
Factor for ductility	$k_7$ [-]	1,0		
<b>Concrete pryout failure</b>				
Factor for pryout failure	$k_8$ [-]	1,3		
<b>Concrete edge failure</b>				
Effective length of anchor for shear loading	$l_f$ [mm]	40	40	40
Effective diameter of anchor	$d_{nom}$	10	12	14
Installation safety factor	$\gamma_{inst}$ [-]	1,0		

<sup>1)</sup> Strength class of the screw / threaded rod

fischer Zykon-Hammerset anchor FZEA II

**Performances**

Characteristic values of resistance under shear loads

**Annex C 2**

Appendix 9 / 11

**Table C3.1: Characteristic values of tension resistance under fire exposure**

	R30 Fire resistance 30 minutes			R60 Fire resistance 60 minutes		
	$N_{Rk,s,fi,30}$ [kN]	$N_{Rk,p,fi,30}$ [kN]	$N^0_{Rk,c,fi,30}$ [kN]	$N_{Rk,s,fi,60}$ [kN]	$N_{Rk,p,fi,60}$ [kN]	$N^0_{Rk,c,fi,60}$ [kN]
FZEA II 10x40 M8, R, HCR	1,1	1,0	1,8	0,9	1,0	1,8
FZEA II 12x40 M10, R, HCR	3,2	1,9	1,8	2,4	1,9	1,8
FZEA II 14x40 M12, R, HCR	4,7	2,3	1,8	3,5	2,3	1,8

	R90 Fire resistance 90 minutes			R120 Fire resistance 120 minutes		
	$N_{Rk,s,fi,90}$ [kN]	$N_{Rk,p,fi,90}$ [kN]	$N^0_{Rk,c,fi,90}$ [kN]	$N_{Rk,s,fi,120}$ [kN]	$N_{Rk,p,fi,120}$ [kN]	$N^0_{Rk,c,fi,120}$ [kN]
FZEA II 10x40 M8, R, HCR	0,8	1,0	1,8	0,7	0,8	1,5
FZEA II 12x40 M10, R, HCR	1,6	1,9	1,8	1,2	1,5	1,5
FZEA II 14x40 M12, R, HCR	2,3	2,3	1,8	1,8	1,8	1,5

**Table C3.2: Characteristic values of shear resistance under fire exposure**

	R30 Fire resistance 30 minutes		R60 Fire resistance 60 minutes	
	$V_{Rk,s,fi,30}$ [kN]	$M^0_{Rk,s,fi,30}$ [Nm]	$V_{Rk,s,fi,60}$ [kN]	$M^0_{Rk,s,fi,60}$ [Nm]
FZEA II 10x40 M8, R, HCR	0,9	1,1	0,8	0,9
FZEA II 12x40 M10, R, HCR	2,3	4,1	1,7	3,1
FZEA II 14x40 M12, R, HCR	2,8	7,3	2,1	5,4

	R90 Fire resistance 90 minutes		R120 Fire resistance 120 minutes	
	$V_{Rk,s,fi,90}$ [kN]	$M^0_{Rk,s,fi,90}$ [Nm]	$V_{Rk,s,fi,120}$ [kN]	$M^0_{Rk,s,fi,120}$ [Nm]
FZEA II 10x40 M8, R, HCR	0,7	0,8	0,6	0,7
FZEA II 12x40 M10, R, HCR	1,1	2,1	0,9	1,5
FZEA II 14x40 M12, R, HCR	1,4	3,6	1,0	2,7

Concrete pryout failure according to EN 1992-4:2018

**Table C3.3: Minimum spacings and minimum edge distances under fire exposure**

Type of anchor	FZEA II 10x40 M8	FZEA II 12x40 M10	FZEA II 14x40 M12
Edge distance <sup>1)</sup> $c_{cr,fi}$ [mm]	2 $h_{ef}$		
$c_{min,fi}$	40	45	50
Spacing $s_{cr,fi}$	2 $c_{cr,fi}$		
$s_{min,fi}$	40	45	50

<sup>1)</sup> For fire exposure from more than one side  $c_{min} \geq 300$  mm

fischer Zykon-Hammerset anchor FZEA II

**Performances**

Characteristic values of resistance under tension and shear loads under fire exposure

**Annex C 3**

Appendix 10 / 11

**Table C4.1: Displacements under tension load**

Type of anchor		FZEA II 10x40 M8	FZEA II 12x40 M10	FZEA II 14x40 M12
Tension load in cracked concrete	N [kN]	1,56	2,93	3,50
Displacement	$\frac{\delta_{N0}}{\delta_{N\infty}}$ [mm]	1,3		
		1,4		
Tension load in uncracked concrete	N [kN]	3,52		
Displacement	$\frac{\delta_{N0}}{\delta_{N\infty}}$ [mm]	1,3		
		1,4		

**Table C4.2: Displacements under shear load**

Type of anchor		FZEA II 10x40 M8	FZEA II 12x40 M10	FZEA II 14x40 M12
Shear load in cracked an uncracked concrete, <b>FZEA II</b>	V [kN]	4,7	7,6	10,7
Displacement	$\frac{\delta_{V0}}{\delta_{V\infty}}$ [mm]	1,3	1,8	2,0
		1,9	2,6	3,0
Shear load in cracked an uncracked concrete, <b>FZEA II R, FZEA II HCR</b>	V [kN]	5,6	8,4	11,6
Displacement	$\frac{\delta_{V0}}{\delta_{V\infty}}$ [mm]	1,8	2,0	2,0
		2,7	3,0	3,0

fischer Zykon-Hammerset anchor FZEA II

**Performances**

Displacements under tension and shear loads

**Annex C 4**

Appendix 11 / 11