

DÉCLARATION DES PERFORMANCES

DoP 0270

pour ancrage pour béton cellulaire fischer FPX-I (cheville métallique à expansion pour utilisation dans le béton cellulaire autoclavé)

FR

1. Code d'identification unique du type de produit: **DoP 0270**
2. Usage(s) prévu(s): **Fixation pour utilisation dans les dalles armées fissurées ou non fissurées ou dans les éléments de maçonnerie en béton cellulaire autoclavé, voir annexes, en particulier les annexes B1 - B5.**
3. Fabricant: **fischerwerke GmbH & Co. KG, Klaus-Fischer-Str. 1, 72178 Waldachtal, Allemagne**
4. Mandataire: **-**
5. Système(s) d'évaluation et de vérification de la constance des performances: **1**
6. Document d'évaluation européen: **EAD 330014-00-0601**
Evaluation Technique Européenne: **ETA-12/0456; 2019-07-19**
Organisme d'évaluation technique: **DIBt- Deutsches Institut für Bautechnik**
Organisme(s) notifié(s): **2873 TU Darmstadt**
7. Performance(s) déclarée(s):
Résistance mécanique et stabilité (BWR 1)
Résistance pour toutes les directions de charge sans bras de levier: Annexe C1
Résistance sous charge de cisaillement avec bras de levier: Annexe C1
Entraxe, distance au bord et épaisseur du support: Annexes B3, B4, C1
Déplacements: Annexe C2
Durabilité: Annexe B1

Sécurité en cas d'incendie (BWR 2)
Réaction au feu: Classe A1
Résistance au feu pour toutes les directions de charge sans bras de levier: Annexe C2
Résistance au feu sous charge de cisaillement avec bras de levier: NPD
Entraxe et distance au bord pour résistance au feu: Annexe C2
8. Documentation technique appropriée et/ou documentation technique spécifique: **-**

Les performances du produit identifié ci-dessus sont conformes aux performances déclarées. Conformément au règlement (UE) no 305/2011, la présente déclaration des performances est établie sous la seule responsabilité du fabricant mentionné ci-dessus.

Signé pour le fabricant et en son nom par:



Dr.-Ing. Oliver Geibig, Directeur Général Business Units & Ingénierie
Tumlingen, 2021-01-15



Jürgen Grün, Directeur Général Chimie & Qualité

Cette DoP a été préparée en plusieurs langues. En cas de différend relatif à l'interprétation, la version anglaise prévaudra.

L'annexe comprend des informations volontaires et complémentaires en langue anglaise dépassant les exigences légales (spécifiées de manière neutre).

Specific Part

1 Technical description of the product

The fischer aircrete anchor FPX-I is a deformation controlled expansion anchor made of galvanised steel. The anchor consists of an internal threaded socket, a cone bolt and an expansion sleeve. The anchor transfers loads into autoclaved aerated concrete via mechanical interlock.

The anchor is set into a predrilled bore hole and anchored with a hexagon installation tool until the installation tool is pushed out of the internal hexagon socket. The fixture is installed with a screw-in part (threaded rods or screw).

The product description is given in Annex A.

2 Specification of the intended use in accordance with the applicable European assessment Document

The performances given in Section 3 are only valid if the anchor is used in compliance with the specifications and conditions given in Annex B.

The verifications and assessment methods on which this European Technical Assessment is based lead to the assumption of a working life of the anchor of at least 50 years. The indications given on the working life cannot be interpreted as a guarantee given by the producer, but are to be regarded only as a means for choosing the right products in relation to the expected economically reasonable working life of the works.

3 Performance of the product and references to the methods used for its assessment

3.1 Mechanical resistance and stability (BWR 1)

Essential characteristic	Performance
Resistance in any load direction without lever arm	See Annex C 1
Resistance in any load direction with lever arm	See Annex C 1
Spacing, edge distance, member thickness	See Annex B 3 and B 4
Displacements	See Annex C 2
Durability	Durability is ensured if the specifications of intended use according to Annex B are taken into account.

3.2 Safety in case of fire (BWR 2)

Essential characteristic	Performance
Reaction to fire	Class A1
Resistance to fire	See Annex C 2

4 Assessment and verification of constancy of performance (AVCP) system applied, with reference to its legal base

In accordance with European Assessment Document EAD No. 330014-00-0601, the applicable European legal act is: [96/582/EC].

The system(s) to be applied is (are): 1

Product description

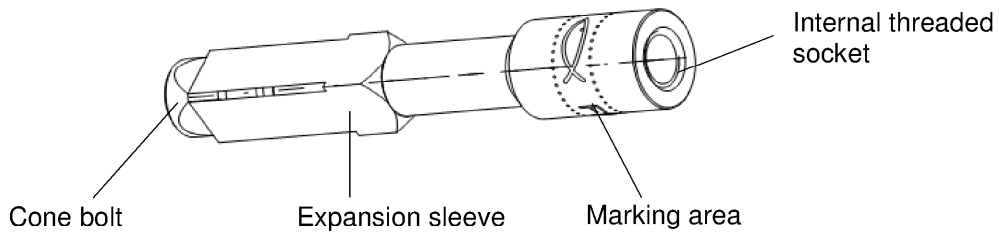

Product installed

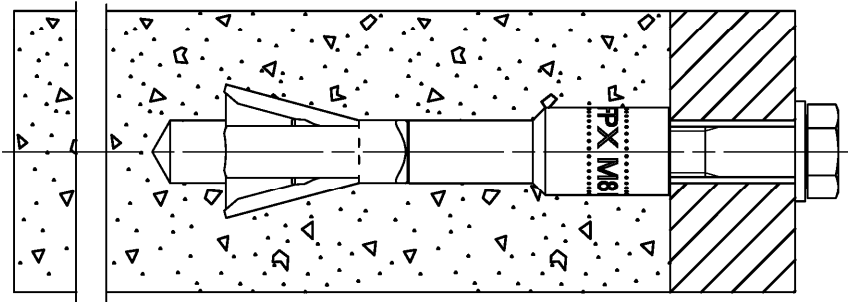

Product label

Product label, example:

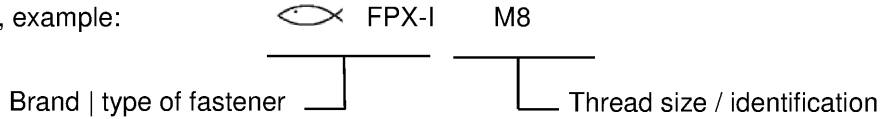

Product dimensions

Table A1.1: Dimension [mm]

Anchor type		FPX-I			
		M6	M8	M10	M12
Internal thread					
Anchor length	L =	75			
Diameter head internal threaded socket	$\varnothing D$ =	14		16	
Diameter cone bolt	$\varnothing d_c$ =	11			

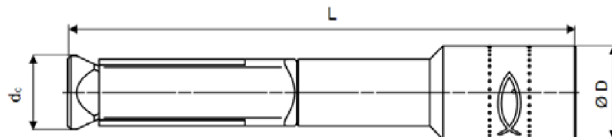

fischer aircrete anchor FPX-I

Product description

Description, label and dimension

Annex A 1

Appendix 3 / 10

Specifications of intended use

fischer aircrete anchor FPX-I	M6	M8	M10	M12
Galvanized steel				
Static and quasi-static loads				
Cracked and uncracked Autoclaved Aerated Concrete (AAC)				
Fire exposure in reinforced slabs according to EN 12602:2016 of strength class $f_{AAC} \geq 3,3 \text{ N/mm}^2$ with dry density $\rho_m \geq 0,50 \text{ kg/dm}^3$ and strength class $f_{AAC} \geq 4,4 \text{ N/mm}^2$ with dry density $\rho_m \geq 0,55 \text{ kg/dm}^3$			✓	

Base material:

- Cracked reinforced slabs (uncracked slabs are included) according to EN 12602:2016 of strength class $f_{AAC} \geq 3,3 \text{ N/mm}^2$ with dry density $\rho_m \geq 0,50 \text{ kg/dm}^3$ and strength class $f_{AAC} \geq 4,4 \text{ N/mm}^2$ with dry density $\rho_m \geq 0,55 \text{ kg/dm}^3$
- Uncracked reinforced slabs according to EN 12602:2016 of strength class $f_{AAC} \geq 1,6 \text{ N/mm}^2$ with dry density $\rho_m \geq 0,25 \text{ kg/dm}^3$ and strength class $f_{AAC} \geq 6,0 \text{ N/mm}^2$ with dry density $\rho_m \geq 0,65 \text{ kg/dm}^3$
- Masonry units according to EN 771-4:2011+A1:2015 of strength class $f_{AAC} \geq 1,6 \text{ N/mm}^2$ with dry density $\rho_m \geq 0,25 \text{ kg/dm}^3$ and strength class $f_{AAC} \geq 6,0 \text{ N/mm}^2$ with dry density $\rho_m \geq 0,65 \text{ kg/dm}^3$
- The mortar strength class of the masonry has to be M 2,5 according to EN 998-2:2017 at minimum

Use conditions (Environmental conditions):

- Structures subject to dry internal conditions (FPX-I)

Design:

- Anchorages are to be designed under the responsibility of an engineer experienced in anchorages and concrete and masonry work
- Verifiable calculation notes and drawings are to be prepared taking account in the loads to be anchored. The position of the anchor is to be indicated on the design drawings
- Design of fastenings according to TR 054, Design Method B.

Table B1.1: Material

Designation	FPX-I
Cone bolt ¹⁾	Steel EN 10263:2018
Expansion sleeve ¹⁾	Steel EN 10277:2018
Internal threaded bolt ¹⁾	Steel EN 10277:2018
Screw-in-parts ^{1, 2)}	Minimum steel strength class 4.8, DIN EN ISO 898-1:2013

¹⁾ Galvanized according to EN ISO 4042:2018, $\geq 5 \mu\text{m}$

²⁾ Screw-in parts (screws and threaded rods including nuts and washer) must comply with the specification in Annex C1.

fischer aircrete anchor FPX-I

Intended use
Specifications

Annex B 1

Appendix 4 / 10

Table B2.1: Installation parameters

Size	FPX-I			
	M6	M8	M10	M12
Nominal drill hole diameter	10			
Maximum drill bit diameter	10,45			
Depth of drill hole to deepest point	80			
	95			
Diameter of clearance hole in the fixture	7	9	12	14
Effective embedment depth	70			
Maximum fastening torque ²⁾	3			
Screw-in depth internal thread	6	8	10	12
	15			

¹⁾ For member thickness $h < 120$ mm the drill hole shall be cleaned and the depth of the drill hole shall be reduced to 80 mm in order to avoid damage on the opposite side of the wall

²⁾ If the anchor cannot retain against the fixture no installation torque may be applied ($T_{max} = 0$ Nm)

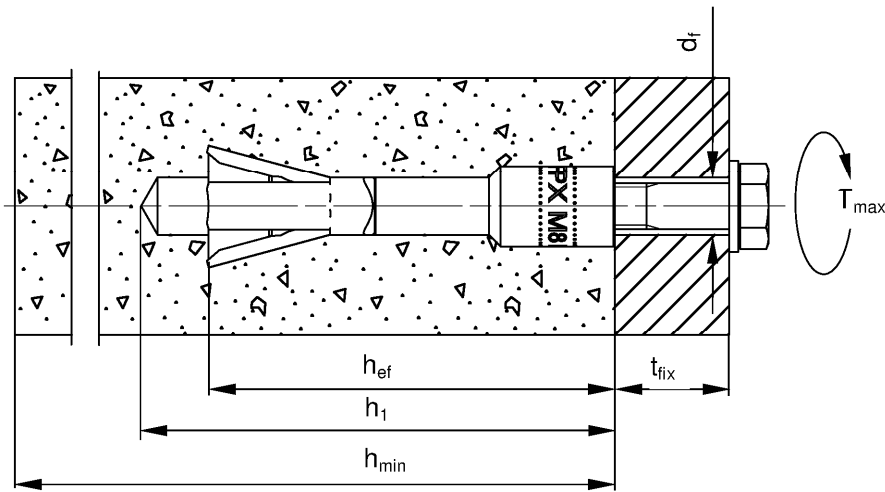

- h_{ef} = Effective embedment depth
- t_{fix} = Thickness of fixture
- h_1 = Depth of drill hole to deepest point
- h_{min} = Minimum thickness of AAC member
- T_{max} = Maximum setting torque
- d_f = Diameter of clearance hole in the fixture

fischer aircrete anchor FPX-I

Intended use
Installation parameters

Annex B 2

Appendix 5 / 10

Table B3.1: Minimum member thickness, minimum spacing and edge distance in AAC - slabs

Size	FPX-I			
	M6	M8	M10	M12
Minimum thickness of AAC - slab	with cleaning ¹⁾		100	
	without cleaning		120	
Minimum spacing	s_{min}		100	
Minimum edge distance	single anchor ²⁾		125 ⁵⁾	
	anchor groups ³⁾		250	
Minimum edge distance, orthogonal to c_1	c_2		1,5 x c_1	
Minimum spacing between	single anchors		600	
	anchors groups ^{3) 4)}		750	

- ¹⁾ For member thickness $h < 120$ mm the drill dust has to be cleaned out of the hole and the depth of the drill hole has to be reduced to 80 mm in order to avoid damage on the opposite side of the slab
- ²⁾ Maximum 2 single anchors in the same formation as anchor groups. For 2 single anchors with spacing smaller than 600 mm ($s_{min} \geq 100$ mm) the same spacing in between and edge distances (a ; c_1) like for the anchor group are valid
- ³⁾ For exclusive tension loads the spacing and edge distances for groups can be reduced to the spacing and edge distances of single anchors
- ⁴⁾ If there is no (free) edge, or the edge distance is $\geq a$, the spacing between anchor groups can be reduced to the spacing between single anchors
- ⁵⁾ The edge distance of reinforced slabs with a width ≤ 700 mm has to be ≥ 150 mm

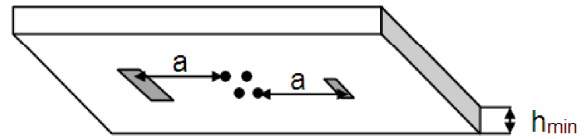
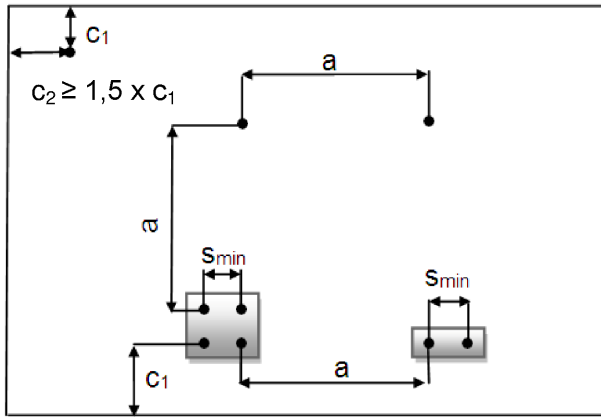

fischer aircrete anchor FPX-I

Intended use

Minimum member thickness, minimum spacing and edge distance in AAC slabs

Annex B 3

Appendix 6 / 10

Table B4.1: Minimum member thickness, minimum spacing and edge distance in AAC - masonry

Size	FPX-I			
	M6	M8	M10	M12
Minimum thickness of AAC - masonry	with cleaning ¹⁾		100	
	without cleaning		120	
Minimum spacing	S_{min}		100	
Minimum distance to non-filled joints, single anchor	C_F		0 ⁵⁾ / 75 ⁶⁾ / 125 ⁷⁾	
Minimum edge distance	single anchor ²⁾		125	
	anchor groups ³⁾		250	
Minimum edge distance, orthogonal to c_1	C_2		$1,5 \times c_1$	
Minimum spacing between	single anchors ²⁾		375	
	anchors groups ^{3) 4)}		750	

- 1) For member thickness $h < 120$ mm, the drill hole shall be cleaned and the depth of the drill hole shall be reduced to 80 mm in order to avoid damage on the opposite side of the wall
- 2) Maximum 2 single anchors in the same formation as the anchor groups. For 2 single anchors with spacing smaller than 375 mm ($S_{min} \geq 100$ mm) the same spacing in between and edge distances (a ; c_1) like for the anchor group are valid
- 3) For exclusive tension loads the spacing and edge distances of anchor groups can be reduced to the spacing and edge distances of single anchors
- 4) If there is no edge, or the edge distance is $\geq a$, the spacing between anchor groups can be reduced to the spacing between single anchors
- 5) For joints completely filled with mortar and a joint width ≤ 12 mm and a compressive strength according to EN 998-2 $\geq f_{AAC}$ AAC no distances to joints are required
- 6) C_F for only tension and /or shear loads parallel to the joints which are not filled with mortar and a joint width ≤ 2 mm
- 7) $C_F = C_1$ for shear load or with a part of the load orthogonal to the joint which are not filled with mortar and a joint width ≥ 0 mm

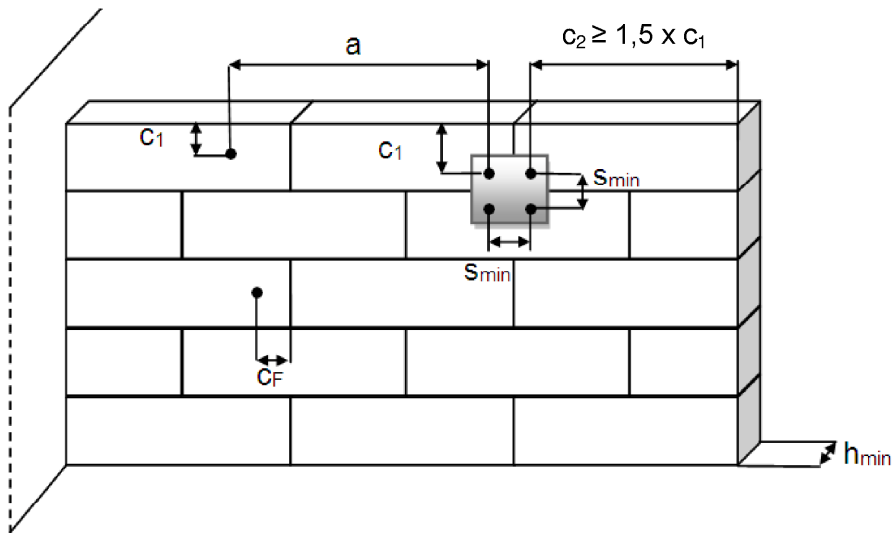

fischer aircrete anchor FPX-I

Intended use

Minimum member thickness, minimum spacing and edge distance in AAC masonry

Annex B 4

Appendix 7 / 10

Installation instruction

- Anchor installation carried out by appropriately qualified personnel and under the supervision of the person responsible for technical matters of the site
- Use of the anchor only as supplied by the manufacturer without exchanging the components of the anchor
- Checking before placing the anchor to ensure that the strength class of the aircrete in which the anchor is to be placed is in the range given and is not lower than that of the aircrete to which the characteristic loads apply
- Drill hole created perpendicular $\pm 5^\circ$ to AAC surface, positioning without damaging the reinforcement
- In case of aborted hole: New drilling at a minimum distance away of twice the depth of the aborted hole or smaller distance if the aborted hole is filled with non-shrinkage, high strength mortar (pressure strength $\geq 30 \text{ N/mm}^2$) and if under shear or oblique tension load it is not the direction of the load application

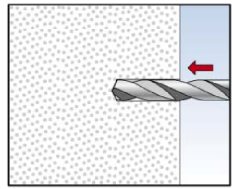

1: Drill the hole. Other methods like punching, to make the hole, are allowed. When the AAC is covered with a hard layer like tiles, the tile has to be drilled with minimum diameter of the head of the internal threaded bolt $\varnothing D$

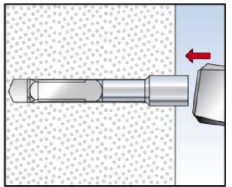

2: Set the fastener until it is flush with the surface of the AAC

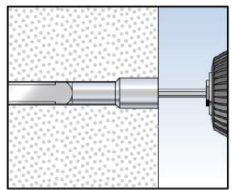

3: Turning the internal thread bolt with the hexagon (approximately 15 turnings are required)

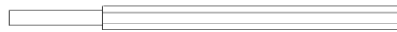

Setting tool for FPX-I M6



Setting tool for FPX-I M8 – M12

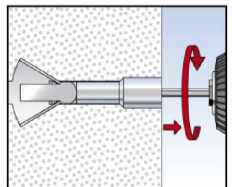

4: By turning the internal thread bolt, the cone is driven into the expansion sleeve. When the optimal expansion is reached, the hexagon is thrown out of the socket. **The turning of the internal thread bolt until the hexagon is thrown out of the socket is compulsory** if tightening is impossible the anchor cannot be loaded

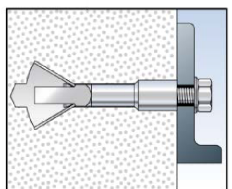

5a: Optional tightening the fastener with a torque $T_{\max} \leq 3 \text{ Nm}$. The anchor could be pulled against the fixture depending on the compressive strength of the AAC.

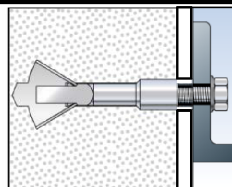

5b: If the anchor cannot support against the fixture (with cover layer) no installation torque may be applied ($T_{\max} = 0$)

fischer aircrete anchor FPX-I

Intended use
Installation instructions

Annex B 5

Appendix 8 / 10

Table C1.1: Characteristic resistance for all load directions

Size	FPX-I						
	M6	M8	M10	M12			
Single anchor in AAC - slabs ¹⁾							
Characteristic resistance in cracked AAC - slabs	F_{Rk} [kN]	$f_{AAC} \geq 3,3, \rho_m \geq 0,50$	1,5				
		$f_{AAC} \geq 4,4, \rho_m \geq 0,55$	2,0				
Characteristic resistance in uncracked AAC - slabs	F_{Rk} [kN]	$f_{AAC} \geq 3,3, \rho_m \geq 0,50$	2,0				
		$f_{AAC} \geq 4,4, \rho_m \geq 0,55$	3,0				
Partial safety factor for AAC - slabs		$\gamma_{MAAC}^{2)}$	1,73				
Single anchor in AAC - masonry ¹⁾							
Characteristic resistance in AAC - masonry ³⁾	F_{Rk} [kN]	$f_{AAC} \geq 1,6, \rho_m \geq 0,25$	0,9				
		$f_{AAC} \geq 2,0, \rho_m \geq 0,35$	1,2				
Intermediate values by linear interpolation	F_{Rk} [kN]	$f_{AAC} \geq 4,0, \rho_m \geq 0,50$	2,5				
		$f_{AAC} \geq 6,0, \rho_m \geq 0,65$	4,0				
Partial safety factor for AAC - masonry		$\gamma_{MAAC}^{2)}$	2,0				
Single anchor in AAC - slabs and AAC - masonry ¹⁾							
Characteristic bending resistance ¹⁾ with lever arm in combination with screw / threaded rod complying with:	ISO 898-1: 2013	$M_{Rk,s}$ [Nm]	4.8	6	15	30	52
			5.8	8	19	37	65
			6.8	9	23	44	78
			8.8	12	30	60	105
Partial safety factor for steel failure		γ_{Ms}	1,25				
Anchor groups in cracked and uncracked AAC - slabs and AAC - masonry with n = 2 to n = 4 anchors ³⁾							
Characteristic resistance for n = 2, n = 4 ⁴⁾ $s_{min} \geq 100$ mm, $c_1 \geq 250$ mm ⁵⁾		$F_{Rk,n}$ [kN]	2 x F_{Rk}				
Characteristic resistance for n ≥ 3 $s_{min} \geq 140$ mm, $c_{min, anchor group} \geq 700$ mm ⁵⁾			n x F_{Rk}				
Characteristic resistance redundancy when the joints are not visible ⁵⁾			0,5 x $F_{Rk,n}$				
Partial safety factor for AAC - slabs		$\gamma_{MAAC}^{2)}$	1,73				
Partial safety factor for AAC - masonry		$\gamma_{MAAC}^{2)}$	2,0				

¹⁾ Maximum 2 single anchors in the same formation as the anchor groups. For 2 single anchors with spacing smaller than a ($s_{min} \geq 100$ mm) the characteristic resistance of the anchor group is decisive

²⁾ The installation safety factor $\gamma_2 = 1,0$ is included

³⁾ The evaluation of $N_{Rk,pb}$ according to TR 054, Section 4.2.1.5 is necessary. The smaller value of $N_{Rk,pb}$ and F_{Rk} is decisive

⁴⁾ Rectangular arrangement according to drawing Annex B3 and B4

⁵⁾ Only for multiple use according to EAD 330747-00-0601

The characteristic strength class f_{AAC} [N/mm²] and the characteristic dry density ρ_m [kg/dm³] have to comply with EN 771-4:2011+A1:2015 for AAC - masonry and EN 12602:2016 for AAC - slabs

Table C2.1: Characteristic resistance for each anchor under fire exposure for all load directions

Size	FPX-I				
	M6	M8	M10	M12	
Characteristic resistance for cracked slabs of strength class $f_{AAC} \geq 3,3$, $\rho_m \geq 0,50$	$F_{Rk,fi}$ [kN]	R30	0,4		
		R60	0,4		
		R90	0,3	0,4	
		R120	0,3		
Characteristic resistance for cracked slabs of strength class $f_{AAC} \geq 4,4$, $\rho_m \geq 0,55$	$F_{Rk,fi}$ [kN]	R30	0,5		
		R60	0,4	0,5	
		R90	0,3	0,5	
		R120	0,3	0,4	
Minimum spacing	$s_{min,fi}$ [mm]	100			
Minimum edge distance	$c_{min,fi}$ [mm]	$c_{min,fi} = 140$ for fire exposure from more than one side $c_{min,fi} \geq 300$ mm			

It must be ensured that local spalling of the autoclaved aerated concrete cover does not occur.

Table C2.2: Displacement under tension loads, shear loads and oblique loads in AAC ¹⁾

Size	FPX-I			
	M6	M8	M10	M12
Displacement tension load in cracked AAC for all AAC strength classes	δ_{N0}	1,0		
	$\delta_{N\infty}$	2,0		
Displacement tension load in uncracked AAC for all AAC strength classes	δ_{N0}	1,0		
	$\delta_{N\infty}$	1,0		
Displacement shear load in cracked and uncracked AAC $f_{AAC} = 1,6 - \rho_m \geq 0,25$ ²⁾	δ_{V0}	2,5		
	$\delta_{V\infty}$	3,7		
Displacement shear load in cracked and uncracked AAC $f_{AAC} \geq 6,0 - \rho_m \geq 0,65$ ²⁾	δ_{V0}	5,0		
	$\delta_{V\infty}$	7,3		

¹⁾ Displacement at service load level $F_{Rk} / (\gamma_{MAAC} \times 1,4)$

²⁾ Intermediate values by linear interpolation, taking in account the AAC strength

fischer aircrete anchor FPX-I

Performances

Characteristic resistance of a fixing point under fire exposure for all load directions
Displacements under tension, shear loads and oblique loads

Annex C 2

Appendix 10 / 10