



DÉCLARATION DES PERFORMANCES

DoP 0397

pour le système d'injection fischer FIS EM Plus (résine pour les scellements d'armatures rapportées)

FR

1. Code d'identification unique du type de produit: **DoP 0397**
2. Usage(s) prévu(s): **Système pour scellement d'armatures rapportées avec taux d'adhérence et résistance à la rupture par fendage améliorés voir annexes, en particulier les annexes B1-B9.**
3. Fabricant: **fischerwerke GmbH & Co. KG, Otto-Hahn-Straße 15, 79211 Denzlingen, Allemagne**
4. Mandataire: **-**
5. Système(s) d'évaluation et de vérification de la constance des performances: **1**
6. Document d'évaluation européen: **EAD 332402-00-0601**
Evaluation Technique Européenne: **ETA-22/0001; 2025-12-16**
Organisme d'évaluation technique: **DIBt- Deutsches Institut für Bautechnik**
Organisme(s) notifié(s): **2873 TU Darmstadt**
7. Performance(s) déclarée(s):
Résistance mécanique et stabilité (BWR 1)
Résistance caractéristique à la charge de traction (charge statique et quasi-statique):
Résistance à la rupture combinée par extraction glissement et par cône de béton dans le béton non fissuré: Annexes C1-C3
Résistance à la rupture du cône béton: Annexe C1
Robustesse: Annexes C1-C3
Résistance à la rupture par fendage: Annexe C1
Influence du béton fissuré sur la résistance à la rupture combinée par extraction glissement et par cône de béton: Annexes C2, C3
8. Documentation technique appropriée et/ou documentation technique spécifique: **-**

Les performances du produit identifié ci-dessus sont conformes aux performances déclarées. Conformément au règlement (UE) no 305/2011, la présente déclaration des performances est établie sous la seule responsabilité du fabricant mentionné ci-dessus.

Signé pour le fabricant et en son nom par:

Alexander Zanocco, Directeur Général des Ventes et Directeur Général de la Recherche & Développement Dieter Pfaff, Chef de la Fédération Internationale de Production et Gestion de la Qualité
Tumlingen, 2026-04-14

Cette DoP a été préparée en plusieurs langues. En cas de différend relatif à l'interprétation, la version anglaise prévaudra.

L'annexe comprend des informations volontaires et complémentaires en langue anglaise dépassant les exigences légales (spécifiées de manière neutre).

Specific Part

1 Technical description of the product

The subject of this European Technical Assessment is the post-installed connection, by anchoring or overlap connection joint, of reinforcing bars (rebars) in existing structures made of normal weight concrete, using the fischer injection system FIS EM Plus in accordance with the regulations for reinforced concrete construction.

Reinforcing bars with a diameter ϕ from 8 to 40 mm according to Annex A and the injection mortar FIS EM Plus are used for the post-installed rebar connection. The rebar is placed into a drilled hole filled with injection mortar and is anchored via the bond between embedded reinforcing bar, injection mortar and concrete.

The product description is given in Annex A.

2 Specification of the intended use in accordance with the applicable European assessment Document

The performances given in Section 3 are only valid if the rebar connection is used in compliance with the specifications and conditions given in Annex B.

The verifications and assessment methods on which this European Technical Assessment is based lead to the assumption of a working life of the rebar connections of at least 50 and/or 100 years. The indications given on the working life cannot be interpreted as a guarantee given by the producer, but are to be regarded only as a means for choosing the right products in relation to the expected economically reasonable working life of the works.

3 Performance of the product and references to the methods used for its assessment

3.1 Mechanical resistance and stability (BWR 1)

| Essential characteristic | Performance |
|---|----------------------|
| Characteristic resistance to tension load (static and quasi-static loading) | See Annexes C1 to C3 |
| Characteristic resistance to tension load (seismic loading) | See Annex C4 |

3.2 Safety in case of fire (BWR 2)

| Essential characteristic | Performance |
|--------------------------|-------------|
| Reaction to fire | Class A1 |

4 Assessment and verification of constancy of performance (AVCP) system applied, with reference to its legal base

In accordance with European Assessment Document EAD No. 332402-00-0601, the applicable European legal act is: [96/582/EC].

The system to be applied is: 1

Installation conditions and application examples reinforcing bars

Figure A1.1:

Column / wall to foundation / slab

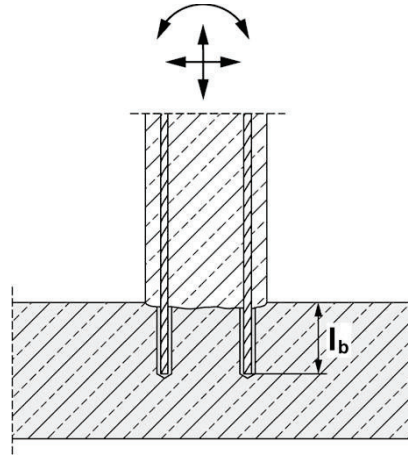
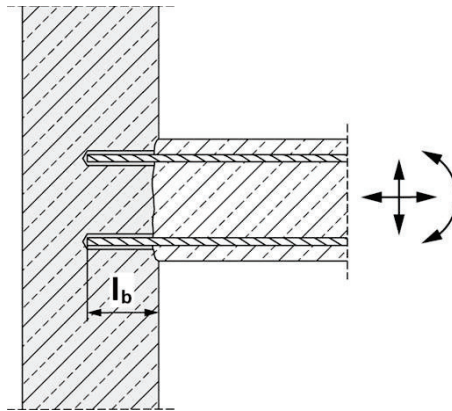

Figure A1.2:

Slab / beam to wall or beam to column



Figures not to scale

fischer injection system FIS EM Plus

Product description
Installation conditions and application examples reinforcing bars

Annex A1
Appendix 2 / 17

Overview system components

Injection cartridge (shuttle cartridge) FIS EM Plus with sealing cap

Sizes: 390 ml, 585 ml, 1500 ml (the 390 ml hard cartridge is shown as an example)

Size foil bag: 500 ml

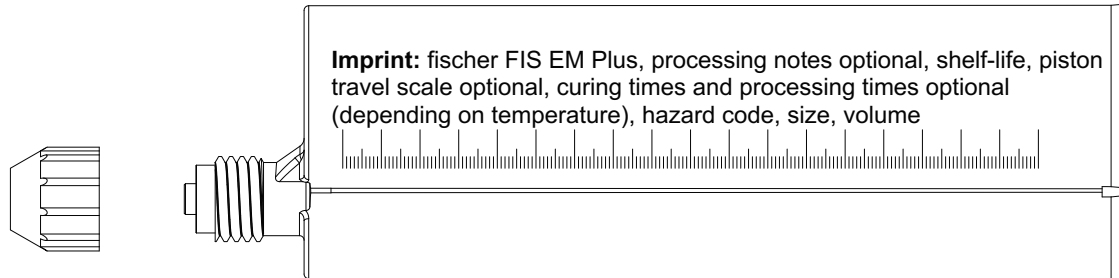

Injection cartridge (coaxial cartridge) FIS EM Plus with sealing cap

Sizes: 300 ml

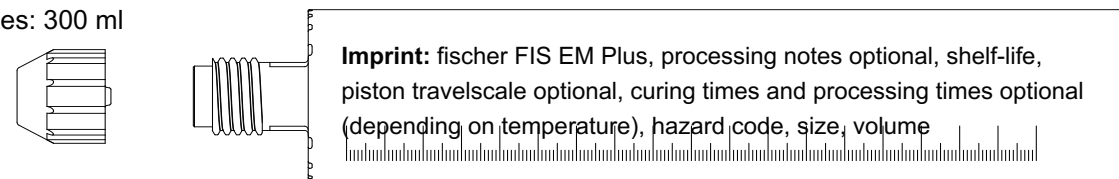

Static mixer FIS MR Plus for injection cartridges ≤ 500 ml

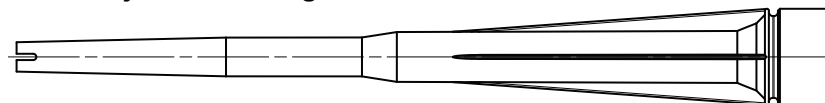

Static mixer FIS UMR for injection cartridges ≥ 500 ml

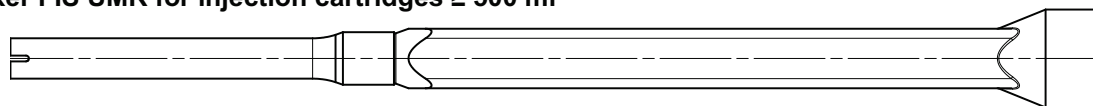

Injection adapter and extension tube $\varnothing 9$ for static mixer FIS MR Plus; Injection adapter and extension tube $\varnothing 9$ or $\varnothing 15$ for static mixer FIS UMR

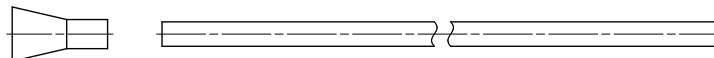

Reinforcing bar (rebar) Sizes: $\varnothing 8$, $\varnothing 10$, $\varnothing 12$, $\varnothing 14$, $\varnothing 16$, $\varnothing 20$, $\varnothing 22$, $\varnothing 24$, $\varnothing 25$, $\varnothing 26$, $\varnothing 28$, $\varnothing 30$, $\varnothing 32$, $\varnothing 34$, $\varnothing 36$, $\varnothing 40$



fischer cleaning brush



Compressed-air cleaning tool with fischer compressed-air nozzle



Figures not to scale

fischer injection system FIS EM Plus

Product description

Overview system components: injection mortar, static mixer, injection adapter, reinforcing bar, cleaning tools

Annex A2

Appendix 3 / 17

Properties of reinforcing bars (rebar)

Figure A3.1:



- The minimum value of related rib area $f_{R,min}$ according to EN 1992-1-1:2011
- The maximum outer rebar diameter over the ribs shall be:
 - The nominal diameter of the bar with rib $\phi + 2 \cdot h_{rib}$ ($h_{rib} \leq 0,07 \cdot \phi$)
 - (ϕ : Nominal diameter of the bar; h_{rib} = rib height of the bar)

Table A3.1: Installation conditions for rebars

| Nominal diameter of the bar | | ϕ | 8 ¹⁾ | | 10 ¹⁾ | | 12 ¹⁾ | | 14 | 16 | 20 | 22 | 24 |
|--------------------------------------|-------------|--------|------------------------------|----|------------------|----|------------------|--------------|----|----|----|----|----|
| Nominal drill hole diameter | d_0 | [mm] | 10 | 12 | 12 | 14 | 14 | 16 | 18 | 20 | 25 | 30 | 30 |
| Drill hole depth | h_0 | | $h_0 \geq l_b$ | | | | | | | | | | |
| Effective embedment depth | $l_b = l_v$ | | acc. to static calculation | | | | | | | | | | |
| Minimum thickness of concrete member | h_{min} | | $l_b + 30$ (≥ 100) | | | | | $l_b + 2d_0$ | | | | | |

| Nominal diameter of the bar | | ϕ | 25 ¹⁾ | | 26 | 28 | 30 | 32 | 34 | 36 | 40 | |
|--------------------------------------|-------------|--------|----------------------------|----|----|----|----|----|----|----|----|--|
| Nominal drill hole diameter | d_0 | [mm] | 30 | 35 | 35 | 35 | 40 | 40 | 40 | 45 | 55 | |
| Drill hole depth | h_0 | | $h_0 \geq l_b$ | | | | | | | | | |
| Effective embedment depth | $l_b = l_v$ | | acc. to static calculation | | | | | | | | | |
| Minimum thickness of concrete member | h_{min} | | $l_b + 2d_0$ | | | | | | | | | |

¹⁾ Both drill hole diameters can be used

Table A3.2: Materials of rebars

| Designation | Reinforcing bar (rebar) |
|--|---|
| Reinforcing bar EN 1992-1-1:2011, Annex C | Bars and de-coiled rods class B or C with f_{yk} and k according to NDP or NCI of EN 1992-1-1/NA $f_{uk} = f_{tk} = k \cdot f_{yk}$ |



fischer injection system FIS EM Plus

Product description
Properties and materials of reinforcing bars (rebar)

Annex A3
Appendix 4 / 17

Specifications of intended use part 1

Table B1.1: Overview use and performance categories

| | | | |
|--|------------------------|---|--|
| Fastenings subject to | | FIS EM Plus with ... | |
| | | Reinforcing bar  | |
| Hammer drilling with standard drill bit  | | all sizes | |
| Hammer drilling with hollow drill bit (fischer "FHD", Heller "Duster Expert"; Bosch „Speed Clean“; Hilti "TE-CD, TE-YD", DreBo „D-Plus“, DreBo „D-Max“)  | | Nominal drill bit diameter (d_0) 12 mm to 35 mm | |
| Use category | I1 dry or wet concrete | all sizes | |
| | I2 water filled hole | all sizes | |
| Characteristic resistance under static and quasi-static loading | in uncracked concrete | all sizes | Tables: C1.1 C1.2 C2.1 C3.1 |
| | in cracked concrete | all sizes | |
| Seismic performance | | all sizes | Table: C4.1 |
| Installation direction | | D3 (downward and horizontal and upwards (e.g. overhead)) | |
| Installation temperature | | $T_{i,min} = -5\text{ °C}$ to $T_{i,max} = +40\text{ °C}$ for the standard variation of temperature after installation | |
| In-service temperature | Temperature range I | -40 °C to +40 °C | (max. short term temperature +40 °C; max. long term temperature +24 °C) |
| | Temperature range II | -40 °C to +60 °C | (max. short term temperature +60 °C; max. long term temperature +35 °C) |
| | Temperature range III | -40 °C to +72 °C | (max. short term temperature +72 °C; max. long term temperature +50 °C) |

fischer injection system FIS EM Plus

Intended use
Specifications part 1

Annex B1
Appendix 5 / 17

Specifications of intended use part 2

Anchorage subject to:

- Static and quasi-static loading: reinforcing bar (rebar) size 8 mm to 40 mm
- Seismic action: reinforcing bar (rebar) size 8 mm to 40 mm

Base materials:

- Compacted reinforced or unreinforced normal weight concrete without fibres according to EN 206:2013+A2:2021.
- Strength classes C20/25 to C50/60 according to EN 206:2013+A2:2021
- Maximum chloride content of 0,40 % (CL 0.40) related to the cement content according to EN 206:2013+A2:2021
- Non-carbonated concrete

Note: In case of a carbonated surface of the existing concrete structure, the carbonated layer shall be removed in the area of the post-installed rebar connection with a diameter of $\phi + 60$ mm prior to the installation of the new rebar. The depth of concrete to be removed shall correspond to at least the minimum concrete cover in accordance with EN 1992-1-1:2011. The foregoing may be neglected if building components are new and not carbonated and if building components are in dry conditions.

Design:

- The structural design according to EN 1992-1-1:2011, EN 1992-1-2:2011 and Annex B3 and B4 are conducted under responsibility of a designer experienced in the field of anchorages and concrete works.
- Verifiable calculation notes and drawings are prepared taking account of the forces to be transmitted.
- Design under static and quasi-static loading and for seismic actions in accordance with EOTA Technical Report TR 069 June 2021.
- The actual position of the reinforcement in the existing structure shall be determined on the basis of the construction documentation and taken into account when designing.
- The shear force must be transferred via the rough joint; the subsequent reinforcement must not be applied for shear force transfer.

Installation:

- Rebar installation carried out by appropriately qualified personnel and under the supervision of the person responsible for technical matters of the site.
- Check the position of the existing rebars (if the position of existing rebars is not known, it shall be determined using a rebar detector suitable for this purpose as well as on the basis of the construction documentation and then marked on the building component for the overlap joint).
- Rebars in overhead installation have to be fixed in their position until the injection mortar is cured.

fischer injection system FIS EM Plus

Intended use
Specifications part 2

Annex B2
Appendix 6 / 17

Table B3.1: Minimum concrete cover c_{min} ¹⁾ depending on the drilling method and the drilling tolerance ²⁾

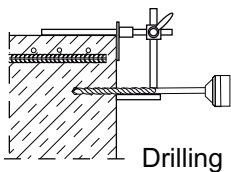
| Drilling method | nominal diameter of reinforcing bar ϕ [mm] | Minimum concrete cover c_{min} | |  |
|--|---|----------------------------------|--------------------------------|---|
| | | Without drilling aid [mm] | With drilling aid [mm] | |
| Hammer drilling with standard drill bit | < 25 | 30 mm + 0,06 $l_b \geq 2 \phi$ | 30 mm + 0,02 $l_b \geq 2 \phi$ | |
| | ≥ 25 | 40 mm + 0,06 $l_b \geq 2 \phi$ | 40 mm + 0,02 $l_b \geq 2 \phi$ | |
| Hammer drilling with hollow drill bit (fischer "FHD", Heller "Duster Expert"; Bosch "Speed Clean"; Hilti "TE-CD, TE-YD") | < 25 | 30 mm + 0,06 $l_b \geq 2 \phi$ | 30 mm + 0,02 $l_b \geq 2 \phi$ | |
| | ≥ 25 | 40 mm + 0,06 $l_b \geq 2 \phi$ | 40 mm + 0,02 $l_b \geq 2 \phi$ | |

¹⁾ Note: The minimum concrete cover as specified in EN 1992-1-1:2011 must be observed.

²⁾ Minimum clear spacing is $a = \max(40 \text{ mm}; 4 \cdot \phi)$

Table B3.2: Dispensers and cartridge sizes corresponding to maximum embedment depth $l_{b,max}$

| reinforcing bars (rebar) | Manual dispenser | Pneumatic or cordless dispenser (small) | Pneumatic or cordless dispenser (large) |
|--------------------------|---|---|---|
| | Cartridge size 300 ml, 390 ml, 500 ml, 585 ml | Cartridge size 300 ml, 390 ml, 500 ml, 585 ml | Cartridge size 1500 ml |
| ϕ [mm] | $l_{b,max}$ [mm] | $l_{b,max}$ [mm] | $l_{b,max}$ [mm] |
| 8 | 1000 | 1000 | 1800 |
| 10 | | | |
| 12 | | | |
| 14 | | 1500 | |
| 16 | | | |
| 20 | 700 | 1300 ¹⁾ | 2000 |
| 22 / 24 / 25 | | 1000 ¹⁾ | |
| 26 / 28 | 500 | 700 ¹⁾ | |
| 30 / 32 / 34 | no performance assessed | 500 ¹⁾ | |
| 36 / 40 | | | |

¹⁾ Not possible with the 300 ml cartridge.

Figures not to scale

fischer injection system FIS EM Plus

Intended use

Minimum concrete cover;
dispenser and cartridge sizes corresponding to maximum embedment depth

Annex B3

Appendix 7 / 17

Table B4.1: Conditions for use static mixer without an extension tube

| | | | | | | | | | | | | | | | |
|---------------------------------|-------------|------|-----------|----|------------|------------|------------|------------|------------|------------|------------|----|----|----|--|
| Nominal drill hole diameter | d_0 | [mm] | 10 | 12 | 14 | 16 | 18 | 20 | 24 | 25 | 28 | 30 | 35 | 40 | |
| Drill hole depth h_0 by using | FIS MR Plus | | ≤ 90 | | ≤ 120 | ≤ 140 | ≤ 150 | ≤ 160 | ≤ 190 | ≤ 210 | | | | | |
| | FIS UMR | | - | - | ≤ 90 | ≤ 160 | ≤ 180 | ≤ 190 | ≤ 220 | | ≤ 250 | | | | |

Table B4.2: Working times t_{work} and curing times t_{cure}

| Temperature at anchoring base [°C] | Maximum processing time ¹⁾ t_{work} | Minimum curing time ²⁾ t_{cure} |
|------------------------------------|---|---|
| -5 to 0 | 240 min ³⁾ | 200 h |
| >0 to 5 | 150 min ³⁾ | 90 h |
| >5 to 10 | 120 min ³⁾ | 40 h |
| >10 to 20 | 30 min | 18 h |
| >20 to 30 | 14 min | 10 h |
| >30 to 40 | 7 min ⁴⁾ | 5 h |

¹⁾ Maximum time from the beginning of the injection to the setting and the final positioning of the rebar

²⁾ For wet concrete the curing time must be doubled

³⁾ If the temperature in the concrete falls below 10 °C the cartridge must be warmed up to +15 °C.

⁴⁾ If the temperature in the concrete exceeds 30 °C the cartridge must be cooled down to +15 °C up to 20 °C

Table B4.3: Installation tools for drilling and cleaning the bore hole and injection of the mortar

| reinforcing bars (rebar) ϕ [mm] | Drilling and cleaning | | | | Injection | |
|---|--|--|------------------------------------|---|------------------------------------|-------------------------------|
| | Nominal drill bit diameter d_0 [mm] | Diameter of cutting edge d_{cut} [mm] | Steel brush diameter d_b [mm] | Diameter of cleaning nozzle ³⁾ [mm] | Diameter of extension tube [mm] | Injection adapter [colour] |
| 8 ¹⁾ | 10 ²⁾ | $\leq 10,50$ | 11 | --- | 9 | --- |
| 10 ¹⁾ | 12 | $\leq 12,50$ | 14 | 11 | | nature |
| | 14 | $\leq 14,50$ | 16 | | | blue |
| 12 ¹⁾ | 16 | $\leq 16,50$ | 20 | 15 | red | |
| | 18 | $\leq 18,50$ | 20 | | yellow | |
| 14 | 20 | $\leq 20,55$ | 25 | 19 | green | |
| 16 | 25 | $\leq 25,55$ | 27 | | black | |
| 20 | 30 | $\leq 30,55$ | 32 | | 28 | grey |
| 22 / 24 | 30 | $\leq 30,55$ | 32 | 9 or 15 | | grey |
| 25 ¹⁾ | 35 | $\leq 35,70$ | 37 | | | brown |
| | 35 | $\leq 35,70$ | 37 | brown | | |
| 26 / 28 | 40 ²⁾ | $\leq 40,70$ | 42 | 38 | | red |
| 30 / 32 / 34 | 45 ²⁾ | $\leq 45,70$ | 47 | | yellow | |
| 36 | 55 ²⁾ | $\leq 55,70$ | 58 | | nature | |

¹⁾ Both drill bit diameters can be used

²⁾ Only hammer drilling with standard drill bit

³⁾ Cleaning nozzle and extension is only necessary if bore hole depth is greater than the length of compressed-air cleaning tool

fischer injection system FIS EM Plus

Intended use

Conditions for use static mixer without an extension tube; Working times and curing times; Installation tools for drilling and cleaning the bore hole and injection of the mortar

Annex B4

Appendix 8 / 17

Safety regulations



Review the Safety Data Sheet (SDS) before use for proper and safe handling!
 Wear well-fitting protective goggles and protective gloves when working with mortar FIS EM Plus.
 Important: Observe the instructions for use provided with each cartridge.

Installation instruction part 1

Hole drilling

Note: Before drilling, remove carbonated concrete; clean contact areas (see Annex B2)
 In case of aborted drill holes the drill hole shall be filled with mortar.

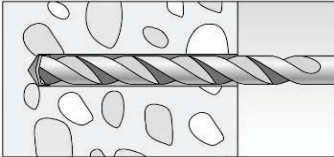
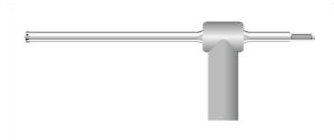
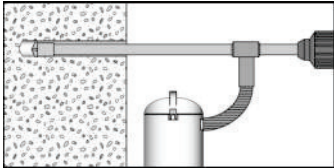
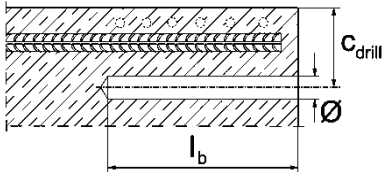
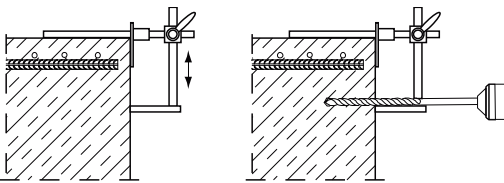
| | | |
|----|---|---|
| 1a | <p>Hammer drilling with standard drill bit</p>  | <p>Drill the hole to the required embedment depth using a hammer drill with carbide drill bit set in rotation hammer mode. Nominal drill hole diameter d_0 (see Table B4.3) and drill hole depth h_0 (see Table A3.1).</p> |
| 1b | <p>Hammer drilling with hollow drill bit</p>  | <p>Check a suitable hollow drill (see Table B1.1) for correct operation of the dust extraction.</p> |
| |  | <p>Drill the hole to the required embedment depth using a hammer drill with hollow drill bit in rotation hammer mode. Dust extraction conditions see drill hole cleaning Annex B6. Nominal drill hole diameter d_0 (see Table B4.3) and drill hole depth h_0 (see Table A3.1).</p> |
| 2 |  | <p>Measure and control concrete cover c $(c_{drill} = c + \varnothing / 2)$ Drill parallel to surface edge and to existing rebar. Where applicable use fischer drilling aid.</p> |
| |  | <p>For holes $l_b > 20$ cm use drilling aid. Three different options can be considered: A) fischer drilling aid B) Slat or spirit level C) Visual check</p> <p>Minimum concrete cover c_{min} see Table B3.1.</p> |

fischer injection system FIS EM Plus

Intended use

Safety regulations; Installation instruction part 1, hole drilling

Annex B5

Appendix 9 / 17

Installation instruction part 2

Drill hole cleaning (hammer drilling with standard drill bit)

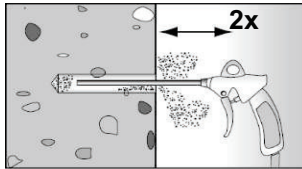

Cleaning the drill hole.
Blow out the drill hole twice, with oil free compressed air ($p \geq 6$ bar).
If the drill hole depth is greater than the length of the compressed-air cleaning tool, an extension and appropriate fischer cleaning nozzle must be used.
Corresponding diameters see **Table B4.3**.



3a

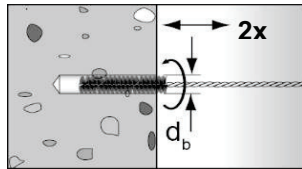

Brush the drill hole twice. For drill hole diameter ≥ 30 mm use a power drill.
For deep holes use an extension. Corresponding brushes see **table B4.3**.

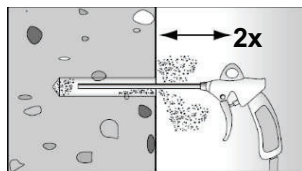

Cleaning the drill hole:
Blow out the drill hole twice, with oil free compressed air ($p \geq 6$ bar).
If the drill hole depth is greater than the length of the compressed-air cleaning tool, an extension and appropriate fischer cleaning nozzle must be used.
Corresponding diameters see **Table B4.3**.



Go to step 4

Drill hole cleaning (hammer drilling with hollow drill bit)

3b

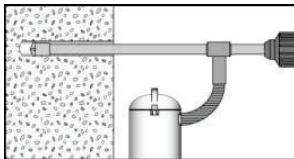

Use a suitable dust extraction system, e. g. fischer FVC 35 M or a comparable dust extraction system with equivalent performance data.

Drill the hole with hollow drill bit. The dust extraction system has to extract the drill dust nonstop during the drilling process and must be adjusted to maximum power. Check the hollow drill for correct operation of the dust extraction.
No further cleaning steps necessary.

Go to step 4

fischer injection system FIS EM Plus



Intended use
Installation instruction part 2, drill hole cleaning

Annex B6

Appendix 10 / 17

Installation instruction part 3

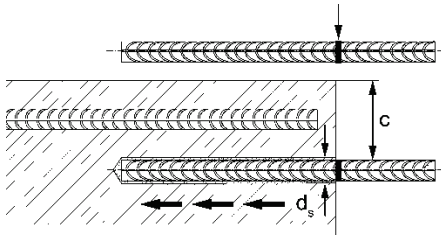
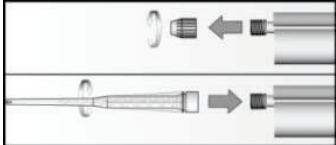
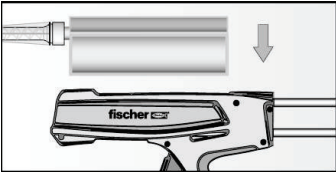
Reinforcing bars (rebar) and cartridge preparation

| | | |
|---|---|---|
| 4 |  | <p>Before use, make asure that the rebar is dry and free of oil or other residue. Mark the embedment depth l_b (e.g. with tape) Insert rebar in borehole, to verify drill hole depth and setting depth l_b.</p> |
| 5 |  | <p>Twist off the sealing cap Twist on the static mixer (the spiral in the static mixer must be clearly visible).</p> |
| 6 |  | <p>Place the cartridge into a suitable dispenser. When using the foilbag, the foil container holder must be used.</p> |
| 7 |  | <p>Press out approximately 10 cm of mortar until the resin is permanently grey in colour. Mortar which is not grey in colour will not cure and must be disposed.</p> |

Go to step 8

fischer injection system FIS EM Plus

Intended use

Installation instruction part 3,
 reinforcing bars (rebar) and cartridge preparation

Annex B7

Appendix 11 / 17

Installation instruction part 4; Installation with FIS EM Plus

Injection of the mortar without extension tube

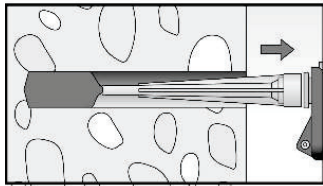
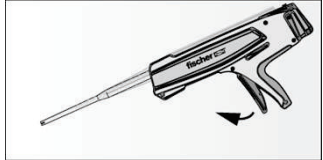
| | | |
|----|---|---|
| 8a |  | <p>Inject the mortar from the back of the hole towards the front and slowly withdraw the static mixer step by step with each trigger pull. Avoid bubbles.</p> <p>Fill holes approximately 2/3 (for $h_0 = l_b$) full, to ensure that the annular gap between the rebar and the concrete will be completely filled with adhesive over the entire embedment length. For $h_0 > l_b$ more mortar is needed.</p> <p>The conditions for mortar injection without extension tube can be found in Table B4.1</p> |
| |  | <p>After injecting, release the dispenser. This will prevent further mortar discharge from the static mixer.</p> |

Injection of the mortar with extension tube

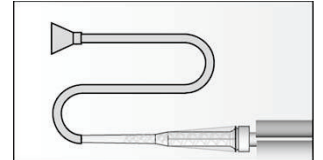
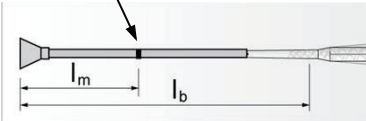
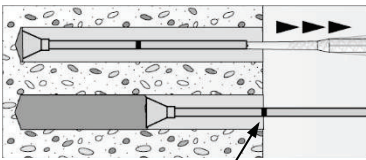
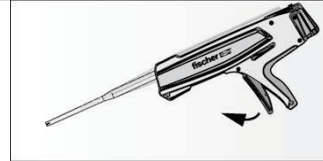
| | | |
|----|--|--|
| |  | <p>Assemble mixing nozzle FIS MR Plus or FIS UMR, extension tube and appropriate injection adapter (see Table B4.3).</p> |
| 8b | <p>Mortar level mark</p>  | <p>Mark the required mortar level l_m and embedment depth l_b with tape or marker on the injection extension tube.</p> <p>a) Estimation:</p> $l_m = \frac{1}{3} \cdot l_b \text{ [mm]}$ <p>b) Precise equation for optimum mortar volume:</p> $l_m = l_b \cdot \left(\left(1,2 \cdot \frac{d_s^2}{d_b^2} - 0,2 \right) \right) \text{ [mm]}$ |
| |  <p>Mortar level mark</p> | <p>Insert injection adapter to back of the hole. Begin injection allowing the pressure of the injected adhesive mortar to push the injection adapter towards the front of the hole. Do not actively pull out!</p> <p>Fill holes approximately 2/3 (for $h_0 = l_b$) full, to ensure that the annular gap between the rebar and the concrete will be completely filled with adhesive over the embedment length. For $h_0 > l_b$ more mortar is needed. When using an injection adapter continue injection until the mortar level mark l_m becomes visible.</p> <p>Maximum embedment depth, see Table B3.2.</p> |
| |  | <p>After injecting, release the dispenser. This will prevent further mortar discharge from the static mixer.</p> |

Go to step 9

fischer injection system FIS EM Plus

Intended use





Installation instruction part 4, mortar injection

Annex B8

Appendix 12 / 17

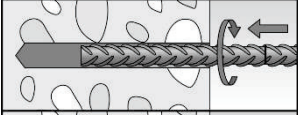
Installation instruction part 5; Installation with FIS EM Plus

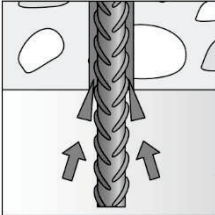
Insert rebar

| | | |
|----|--|--|
| 9 |  | <p>Insert the rebar slowly twisted into the borehole until the embedment mark is reached. Recommendation: Rotation back and forth of the reinforcement bar makes pushing easy</p> |
| 10 |  | <p>After installing the rebar the annular gap must be completely filled with mortar.</p> <p>Proper installation</p> <ul style="list-style-type: none">• Desired embedment depth is reached l_b: embedment mark at concrete surface• Excess mortar flows out of the borehole after the rebar have been fully inserted up to the embedment mark. |
| 11 |  | <p>For overhead installation, support the rebar and secure it from falling till mortar started to harden, e.g. using wedges.</p> |
| 12 |  | <p>Observe the working time "t_{work}" (see Table B4.2), which varies according to temperature of base material. Minor adjustments to the rebar position may be performed during the working time</p> <p>Full load may be applied only after the curing time "t_{cure}" has elapsed (see Table B4.2)</p> |

fischer injection system FIS EM Plus

Intended use
Installation instruction part 5, insert rebar

Annex B9
Appendix 13 / 17

Table C1.1: Characteristic resistance under tension loading for reinforcing bars

| Size | | All sizes | | | |
|--|--------------------|-----------|--------------------|---------------|---------------|
| Characteristic resistance under tension loading | | | | | |
| Installation factor | γ_{inst} | [-] | See Annex C2 to C3 | | |
| Factors for the compressive strength of concrete > C20/25 | | | | | |
| Increasing factor ψ_c for cracked or uncracked concrete $\tau_{Rk,C(X/Y)} = \psi_c \cdot \tau_{Rk,C(20/25)}$ | C25/30 | [-] | 1,02 | | |
| | C30/37 | | 1,04 | | |
| | C35/45 | | 1,06 | | |
| | C40/50 | | 1,07 | | |
| | C45/55 | | 1,08 | | |
| | C50/60 | | 1,09 | | |
| Concrete cone failure | | | | | |
| Uncracked concrete | $k_{ucr,N}$ | [-] | 11,0 | | |
| Cracked concrete | $k_{cr,N}$ | | 7,7 | | |
| Edge distance | $c_{cr,N}$ | [mm] | $1,5 \cdot l_b$ | | |
| Spacing | $s_{cr,N}$ | | $3 \cdot l_b$ | | |
| Factors for sustained tension loading | | | | | |
| Temperature range | | | 24 °C / 40 °C | 35 °C / 60 °C | 50 °C / 72 °C |
| Factor | ψ_{sus}^0 | [-] | 0,77 | 0,60 | 0,48 |
| Factor | $\psi_{sus,100}^0$ | | 0,77 | 0,60 | 0,71 |

Table C1.2: Essential characteristics under tension loading for reinforcing bars in hammer drilled holes; uncracked or cracked concrete; working life 50 and 100 years

| Nominal diameter of the bar | | ϕ | 8 | 10 | 12 | 14 | 16 | 18 | 20 | 22 | 24 | 25 | 26 | 28 | 30 | 32 | 34 | 36 | 40 |
|--|-------|--------|------|----|----|----|----|----|----|----|----|----|----|----|----|----|----|----|----|
| Bond-splitting failure for working life of 50 and 100 years | | | | | | | | | | | | | | | | | | | |
| Calculation diameter | d | [mm] | 8 | 10 | 12 | 14 | 16 | 18 | 20 | 22 | 24 | 25 | 26 | 28 | 30 | 32 | 34 | 36 | 40 |
| Hammer-drilling with standard drill bit or hollow drill bit for 50 and 100 years | | | | | | | | | | | | | | | | | | | |
| Product basic factor | A_k | [-] | 4,4 | | | | | | | | | | | | | | | | |
| Exponent for influence of concrete compressive strength | sp1 | | 0,33 | | | | | | | | | | | | | | | | |
| Exponent for influence of rebar diameter ϕ | sp2 | | 0,34 | | | | | | | | | | | | | | | | |
| Exponent for influence of concrete cover c_d | sp3 | | 0,62 | | | | | | | | | | | | | | | | |
| Exponent for influence of side concrete cover (c_{max} / c_d) | sp4 | | 0,33 | | | | | | | | | | | | | | | | |
| Exponent for influence of anchorage length l_b | lb1 | | 0,68 | | | | | | | | | | | | | | | | |

| | |
|---|-------------------------------------|
| fischer injection system FIS EM Plus | Annex C1 Appendix 14 / 17 |
| Performances Characteristic resistance under tension loading for reinforcing bars; uncracked or cracked concrete; working life 50 and 100 years | |

Table C2.1: Characteristic resistance under tension loading for reinforcing bars in hammer drilled holes; uncracked or cracked concrete; working life 50 years

| Nominal diameter of the bar | | ϕ | 8 | 10 | 12 | 14 | 16 | 18 | 20 | 22 | 24 | | |
|--|--------------------|--------------------|----------------------|------|------|------|------|------|------|------|------|------|------|
| Combined pullout and concrete cone failure | | | | | | | | | | | | | |
| Calculation diameter | d | [mm] | 8 | 10 | 12 | 14 | 16 | 18 | 20 | 22 | 24 | | |
| Uncracked concrete | | | | | | | | | | | | | |
| Characteristic bond resistance in uncracked concrete C20/25 | | | | | | | | | | | | | |
| Hammer-drilling with standard drill bit or hollow drill bit (dry or wet concrete) | | | | | | | | | | | | | |
| Tem- perature range | I: 24 °C / 40 °C | $\tau_{Rk,ucr,50}$ | [N/mm ²] | 16,0 | 16,8 | 16,1 | 15,5 | 15,0 | 14,6 | 14,2 | 14,0 | 13,6 | |
| | II: 35 °C / 60 °C | | | 16,0 | 15,0 | 15,0 | 14,0 | 14,0 | 13,0 | 13,0 | 13,0 | 13,0 | 12,0 |
| | III: 50 °C / 72 °C | | | 15,0 | 14,0 | 14,0 | 13,0 | 13,0 | 12,0 | 12,0 | 12,0 | 12,0 | 12,0 |
| Hammer-drilling with standard drill bit or hollow drill bit (water filled hole) | | | | | | | | | | | | | |
| Tem- perature range | I: 24 °C / 40 °C | $\tau_{Rk,ucr,50}$ | [N/mm ²] | 16,0 | 16,8 | 16,1 | 14,9 | 14,4 | 13,4 | 13,0 | 12,1 | 11,8 | |
| | II: 35 °C / 60 °C | | | 16,0 | 16,0 | 14,0 | 13,0 | 12,0 | 12,0 | 11,0 | 11,0 | 10,0 | |
| | III: 50 °C / 72 °C | | | 15,0 | 14,0 | 13,0 | 12,0 | 12,0 | 11,0 | 11,0 | 10,0 | 10,0 | |
| Installation factors | | | | | | | | | | | | | |
| Dry or wet concrete | γ_{inst} | [-] | 1,0 | | | | | | | | | | |
| Water filled hole | | | 1,4 | | | | | | | | | | |
| Influence of cracked concrete on combined pullout and concrete cone failure | | | | | | | | | | | | | |
| Hammer-drilling with standard drill bit or hollow drill bit (dry or wet concrete / water filled holes) | | | | | | | | | | | | | |
| Factor for cracked concrete | $\Omega_{cr,03}$ | [-] | 0,91 | 0,91 | 0,91 | 0,91 | 0,91 | 0,91 | 0,92 | 0,92 | 0,92 | | |

| Nominal diameter of the bar | | ϕ | 25 | 26 | 28 | 30 | 32 | 34 | 36 | 40 | |
|--|--------------------|--------------------|----------------------|------|------|------|------|------|------|------|------|
| Combined pullout and concrete cone failure | | | | | | | | | | | |
| Calculation diameter | d | [mm] | 25 | 26 | 28 | 30 | 32 | 34 | 36 | 40 | |
| Uncracked concrete | | | | | | | | | | | |
| Characteristic bond resistance in uncracked concrete C20/25 | | | | | | | | | | | |
| Hammer-drilling with standard drill bit or hollow drill bit (dry or wet concrete) | | | | | | | | | | | |
| Tem- perature range | I: 24 °C / 40 °C | $\tau_{Rk,ucr,50}$ | [N/mm ²] | 13,5 | 13,3 | 13,1 | 12,9 | 12,7 | 12,5 | 12,4 | 12,1 |
| | II: 35 °C / 60 °C | | | 12,0 | 12,0 | 12,0 | 12,0 | 12,0 | 11,0 | 11,0 | 11,0 |
| | III: 50 °C / 72 °C | | | 11,0 | 11,0 | 11,0 | 11,0 | 11,0 | 11,0 | 10,0 | 10,0 |
| Hammer-drilling with standard drill bit or hollow drill bit (water filled hole) | | | | | | | | | | | |
| Tem- perature range | I: 24 °C / 40 °C | $\tau_{Rk,ucr,50}$ | [N/mm ²] | 11,5 | 11,4 | 10,6 | 10,5 | 10,3 | 9,0 | 8,0 | 8,0 |
| | II: 35 °C / 60 °C | | | 10,0 | 10,0 | 10,0 | 9,0 | 9,0 | 9,0 | 8,0 | 8,0 |
| | III: 50 °C / 72 °C | | | 9,0 | 9,0 | 9,0 | 9,0 | 8,0 | 8,0 | 8,0 | 8,0 |
| Installation factors | | | | | | | | | | | |
| Dry or wet concrete | γ_{inst} | [-] | 1,0 | | | | | | | | |
| Water filled hole | | | 1,4 | | | | | | | | |
| Influence of cracked concrete on combined pullout and concrete cone failure | | | | | | | | | | | |
| Hammer-drilling with standard drill bit or hollow drill bit (dry or wet concrete / water filled holes) | | | | | | | | | | | |
| Factor for cracked concrete | $\Omega_{cr,03}$ | [-] | 0,92 | 0,92 | 0,92 | 0,92 | 0,93 | 0,93 | 0,93 | 0,93 | |

fischer injection system FIS EM Plus

Performances

Characteristic resistance under tension loading for reinforcing bars; uncracked or cracked concrete; working life 50 years

Annex C2

Appendix 15 / 17

Table C3.1: Characteristic resistance under tension loading for reinforcing bars in hammer drilled holes; uncracked or cracked concrete; working life 100 years

| Nominal diameter of the bar | | ϕ | 8 | 10 | 12 | 14 | 16 | 18 | 20 | 22 | 24 | | |
|--|--------------------|---------------------|----------------------|------|------|------|------|------|------|------|------|------|-----|
| Combined pullout and concrete cone failure | | | | | | | | | | | | | |
| Calculation diameter | d | [mm] | 8 | 10 | 12 | 14 | 16 | 18 | 20 | 22 | 24 | | |
| Uncracked concrete | | | | | | | | | | | | | |
| Characteristic bond resistance in uncracked concrete C20/25 | | | | | | | | | | | | | |
| Hammer-drilling with standard drill bit or hollow drill bit (dry or wet concrete) | | | | | | | | | | | | | |
| Tem- perature range | I: 24 °C / 40 °C | $\tau_{Rk,ucr,100}$ | [N/mm ²] | 12,0 | 13,8 | 13,2 | 12,7 | 12,3 | 12,0 | 11,6 | 11,5 | 11,2 | |
| | II: 35 °C / 60 °C | | | 12,0 | 11,3 | 11,3 | 10,5 | 10,5 | 9,8 | 9,8 | 9,8 | 9,8 | 9,0 |
| | III: 50 °C / 72 °C | | | 8,3 | 8,4 | 8,4 | 8,5 | 8,5 | 7,8 | 7,8 | 7,8 | 7,8 | 7,8 |
| Hammer-drilling with standard drill bit or hollow drill bit (water filled hole) | | | | | | | | | | | | | |
| Tem- perature range | I: 24 °C / 40 °C | $\tau_{Rk,ucr,100}$ | [N/mm ²] | 12,0 | 13,8 | 13,2 | 12,2 | 11,8 | 11,0 | 10,7 | 9,9 | 9,7 | |
| | II: 35 °C / 60 °C | | | 12,0 | 12,0 | 10,5 | 9,8 | 9,0 | 9,0 | 8,3 | 8,3 | 7,5 | |
| | III: 50 °C / 72 °C | | | 8,3 | 8,4 | 7,8 | 7,8 | 7,8 | 7,2 | 7,2 | 6,5 | 6,5 | |
| Installation factors | | | | | | | | | | | | | |
| Dry or wet concrete | γ_{inst} | [-] | 1,0 | | | | | | | | | | |
| Water filled hole | | | 1,4 | | | | | | | | | | |
| Influence of cracked concrete on combined pullout and concrete cone failure | | | | | | | | | | | | | |
| Hammer-drilling with standard drill bit or hollow drill bit (dry or wet concrete / water filled holes) | | | | | | | | | | | | | |
| Factor for cracked concrete | $\Omega_{cr,03}$ | [-] | 0,91 | 0,91 | 0,91 | 0,91 | 0,91 | 0,91 | 0,92 | 0,92 | 0,92 | | |

| Nominal diameter of the bar | | ϕ | 25 | 26 | 28 | 30 | 32 | 34 | 36 | 40 | |
|--|--------------------|---------------------|----------------------|------|------|------|------|------|------|------|-----|
| Combined pullout and concrete cone failure | | | | | | | | | | | |
| Calculation diameter | d | [mm] | 25 | 26 | 28 | 30 | 32 | 34 | 36 | 40 | |
| Uncracked concrete | | | | | | | | | | | |
| Characteristic bond resistance in uncracked concrete C20/25 | | | | | | | | | | | |
| Hammer-drilling with standard drill bit or hollow drill bit (dry or wet concrete) | | | | | | | | | | | |
| Tem- perature range | I: 24 °C / 40 °C | $\tau_{Rk,ucr,100}$ | [N/mm ²] | 11,1 | 10,9 | 10,8 | 10,6 | 10,5 | 10,3 | 10,1 | 9,9 |
| | II: 35 °C / 60 °C | | | 9,0 | 9,0 | 9,0 | 9,0 | 9,0 | 8,3 | 8,3 | 8,3 |
| | III: 50 °C / 72 °C | | | 7,2 | 7,2 | 7,2 | 7,2 | 7,2 | 7,2 | 6,5 | 6,5 |
| Hammer-drilling with standard drill bit or hollow drill bit (water filled hole) | | | | | | | | | | | |
| Tem- perature range | I: 24 °C / 40 °C | $\tau_{Rk,ucr,100}$ | [N/mm ²] | 9,4 | 9,3 | 8,7 | 8,6 | 8,5 | 6,8 | 6,0 | 6,0 |
| | II: 35 °C / 60 °C | | | 7,5 | 7,5 | 7,5 | 6,8 | 6,8 | 6,8 | 6,0 | 6,0 |
| | III: 50 °C / 72 °C | | | 5,9 | 5,9 | 5,9 | 5,2 | 5,2 | 5,2 | 5,2 | 5,2 |
| Installation factors | | | | | | | | | | | |
| Dry or wet concrete | γ_{inst} | [-] | 1,0 | | | | | | | | |
| Water filled hole | | | 1,4 | | | | | | | | |
| Influence of cracked concrete on combined pullout and concrete cone failure | | | | | | | | | | | |
| Hammer-drilling with standard drill bit or hollow drill bit (dry or wet concrete / water filled holes) | | | | | | | | | | | |
| Factor for cracked concrete | $\Omega_{cr,03}$ | [-] | 0,92 | 0,92 | 0,92 | 0,92 | 0,93 | 0,93 | 0,93 | 0,93 | |

fischer injection system FIS EM Plus

Performances

Characteristic resistance under tension loading for reinforcing bars; uncracked or cracked concrete; working life 100 years

Annex C3

Appendix 16 / 17

Table C4.1: Characteristic resistance under tension loading for reinforcing bars (rebars) in concrete under seismic action; working life of 50 and 100 years

| Nominal diameter of the bar | | ϕ | 8 | 10 | 12 | 14 | 16 | 18 | 20 | 22 | 24 | 25 | 26 | 28 | 30 | 32 | 34 | 36 | 40 | |
|---|-----------------------|----------------------|------|------|------|------|------|------|------|------|------|------|------|------|------|------|------|------|------|------|
| Resistance to pull-out failure in uncracked concrete under cyclic loading for working life of 50 and 100 years | | | | | | | | | | | | | | | | | | | | |
| Hammer-drilling with standard drill bit or hollow drill bit (dry or wet concrete) | | | | | | | | | | | | | | | | | | | | |
| Reduction factor for pull-out Resistance under seismic action | $\alpha_{eq,p}$ | [N/mm ²] | 0,76 | | | | | | | | | | | | 1,0 | | | | | |
| Influence of increased crack width on resistance to pull-out failure for working life of 50 and 100 years | | | | | | | | | | | | | | | | | | | | |
| Hammer-drilling with standard drill bit or hollow drill bit (dry or wet concrete) | | | | | | | | | | | | | | | | | | | | |
| Factor for influence of cracked concrete | $\Omega_{cr,05}^{1)}$ | [-] | 0,86 | 0,86 | 0,86 | 0,86 | 0,86 | 0,86 | 0,86 | 0,86 | 0,86 | 0,86 | 0,86 | 0,86 | 0,87 | 0,87 | 0,87 | 0,87 | 0,87 | |
| | $\Omega_{cr,08}^{1)}$ | | 0,76 | 0,76 | 0,76 | 0,76 | 0,76 | 0,76 | 0,76 | 0,76 | 0,76 | 0,76 | 0,76 | 0,76 | 0,76 | 0,76 | 0,76 | 0,73 | 0,70 | 0,63 |
| Resistance to bond-splitting failure under cyclic loading for working life of 50 and 100 years | | | | | | | | | | | | | | | | | | | | |
| Hammer-drilling with standard drill bit or hollow drill bit (dry or wet concrete) | | | | | | | | | | | | | | | | | | | | |
| Reduction factor for bond-splitting resistance under seismic action | $\alpha_{eq,sp}$ | [-] | 0,94 | | | | | | | | | | | | | | | | | |

1) Assumed crack width in accordance with EOTA Technical Report TR 069 June 2021; Section 3.6.

fischer injection system FIS EM Plus

Performances

Characteristic resistance under tension loading for reinforcing bars (rebars) in concrete under seismic action working life of 50 and 100 years

Annex C4

Appendix 17 / 17