



## DÉCLARATION DES PERFORMANCES

### DoP 0303

pour ETE cheville universelle fischer DuoPower (Cheville plastique pour l'utilisation dans le béton et la maçonnerie)

FR

1. Code d'identification unique du type de produit: DoP 0303
2. Usage(s) prévu(s): Cheville plastique pour usage multiple dans le béton et la maçonnerie pour applications non structurelles (catégorie d'utilisation a, b);, voir annexes, en particulier les annexes B1 - B4.
3. Fabricant: fischerwerke GmbH & Co. KG, Klaus-Fischer-Str. 1, 72178 Waldachtal, Allemagne
4. Mandataire: -
5. Système(s) d'évaluation et de vérification de la constance des performances: 2+
6. Document d'évaluation européen: EAD 330284-00-0604 (June 2018)  
Evaluation Technique Européenne: ETA-22/0512; 2022-08-01  
Organisme d'évaluation technique: Kiwa Nederland B.V.  
Organisme(s) notifié(s): 2873 TU Darmstadt
7. Performance(s) déclarée(s):  
**Résistance mécanique et stabilité (BWR 4)**  
Résistance à la rupture de l'acier sous charge de traction: Annexe C1  
Résistance à la rupture de l'acier ou du polymère sous charge de cisaillement: Annexe C1  
Résistance à l'extraction glissement ou à la rupture du béton ou à la rupture du polymère sous charge de traction (groupe du matériau support a): Annexe C2  
Résistance dans toutes les directions de charge sans bras de levier (groupes du matériau support b): Annexe C3  
Distance au bord et entraxe (groupe du matériau support a): Annexe B2  
Distance au bord et entraxe (groupes du matériau support b): Annexe B3  
Déplacements sous charge à court et long terme : Annexe C2  
  
Durabilité: Annexes A4, B1  
  
**Sécurité en cas d'incendie (BWR 2)**  
Réaction au feu: Classe A1  
Résistance au feu: NPD
8. Documentation technique appropriée et/ou documentation technique spécifique: -

Les performances du produit identifié ci-dessus sont conformes aux performances déclarées. Conformément au règlement (UE) no 305/2011, la présente déclaration des performances est établie sous la seule responsabilité du fabricant mentionné ci-dessus.

Signé pour le fabricant et en son nom par:

Dr.-Ing. Oliver Geibig, Directeur Général Business Units & Ingénierie  
Tumlingen, 2022-08-15

Jürgen Grün, Directeur Général Chimie & Qualité

Cette DoP a été préparée en plusieurs langues. En cas de différend relatif à l'interprétation, la version anglaise prévaudra.

L'annexe comprend des informations volontaires et complémentaires en langue anglaise dépassant les exigences légales (spécifiées de manière neutre).

# Specific parts

## 1 Technical description of the product

The plastic anchor “fischer universal plug DuoPower ETA” is a plastic anchor consisting of a sleeve and a screw. The plastic sleeve is expanded by screwing in the screw which presses the sleeve against the wall of the drilled hole.

Polyamide PA6 of grey colour and polypropylene PP of red colour is used as material for the sleeve. The screws are made of galvanised steel, galvanised steel with additional organic layer or stainless steel of corrosion resistance class II or III. There are three variants of the fischer PowerFast II: a countersunk screw, a raised countersunk head screw, a pan head screw. There are also three variants of the special screw: a countersunk screw, a hexagonal screw and a hexagonal screw with washer. Specific dimensions, drawings and material parameters are shown in Annex A.

## 2 Specification of the intended use(s) in accordance with the applicable European Assessment Document (hereinafter EAD)

The performances given in section 3 are only valid if the anchor is used in compliance with the specifications and conditions given in Annex B.

The plastic anchor “fischer universal plug DuoPower ETA” is intended for anchorages subject to static and quasi-static loading. The applicable base material groups are “a” and “b”.

The verifications and assessment methods on which this European Technical Assessment is based on lead to the assumption of a working life of the plastic anchor “fischer universal plug DuoPower ETA” for the intended use of 50 years when installed in the works provided that the plastic anchor is subject to appropriate installation.

The indications given on the working life cannot be interpreted as a guarantee given by the producer, but are to be regarded only as a means for choosing the right products in relation to the expected economically reasonable working life of the works.

### 3 Performance of the product and references to the methods used for its assessment

#### 3.1 Basic Works Requirements 2: Safety in case of fire

Table 3.1 Basic Works Requirements 2: Safety in case of fire

Essential characteristic	Performance
Reaction to fire	Class A 1
Resistance to fire	no performance assessed

#### 3.2 Basic Works Requirements 4: Mechanical resistance and stability

Table 3.2 Basic Works Requirements 4: Mechanical resistance and stability

Essential characteristic	Performance
Resistance to steel failure under tension loading	see Annex C 1
Resistance to steel or polymer failure under shear loading	see Annex C 1
Resistance to pull-out or concrete failure or polymer failure under tension loading (only base material group "a")	see Annex C 2
Resistance in any load direction without lever arm (only base material group "b")	see Annex C 3
Edge distance and spacing	see Annex B 2 and B 3
Displacements under short-term and long-term loading	see Annex C 2

#### 3.3 Other essential characteristics

Table 3.3 Other essential characteristics

Essential characteristic	Performance	
Durability	Corrosion of Metal parts	for screws see Annex A 4 and Annex B 1
	High alkalinity of plastic sleeve	no negative effects

### **3.4 Reference documents**

Following standards or EADs will be referred to in this European Technical Assessment. All undated references are to be understood as references to the dated versions listed below.

- EOTA European Assessment Document EAD 330284-00-0604 June 2018 Plastic anchors for redundant non-structural systems in concrete and masonry
- EOTA Technical Report TR 051 Edition April 2018 Job site tests of plastic anchors and screws
- EOTA Technical Report TR 064 Edition May 2018 Design of plastic anchors in concrete and masonry
- EN 206:2013+A2:2021 Concrete – Specification, performance, production and conformity
- EN 771-1:2011+A1:2015 Specification for masonry units – Part 1: Clay masonry units
- EN 771-2:2011+A1:2015 Specification for masonry units – Part 2: Calcium silicate
- EN 998-2:2017 Specification for mortar for masonry - Part 2: Masonry mortar
- EN 1993-1-4:2006 + A1:2015 Eurocode 3: Design of steel structures - Part 1-4: General rules - Supplementary rules for stainless steels
- EN ISO 4042:2018 Fasteners – Electroplated coating systems

### **4 Assessment and verification of constancy of performance (hereinafter AVCP) system applied, with reference to its legal base**

In accordance with European Assessment Document EAD 330284-00-0604 the applicable European legal act is: 97/463/EC.

The System to be applied is: 2+

Installed anchor DuoPower ETA, e.g. with special screw

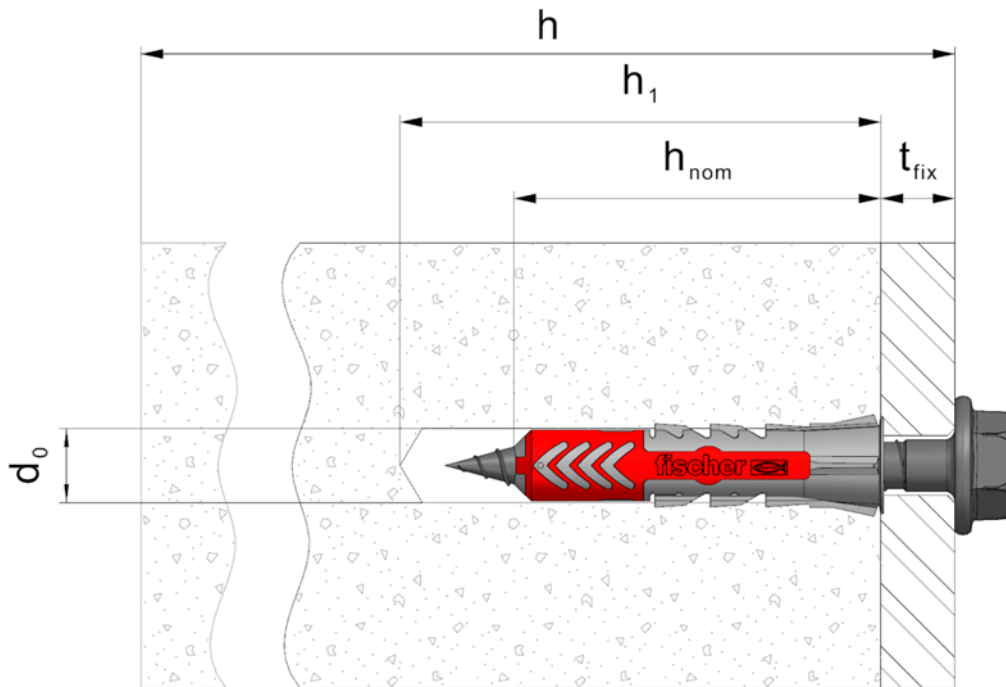

**Legend**

- $d_0$  = Nominal drill hole diameter
- $h_{nom}$  = Overall plastic anchor embedment depth in the base material
- $h_1$  = Depth of drill hole to deepest point
- $h$  = Thickness of member (wall)
- $t_{fix}$  = Thickness of fixture including non-load-bearing layer

Figure not to scale

**fischer universal plug DuoPower ETA**

**Product description**  
Installed anchor

**Annex A 1**

Annex 4 / 14

# Anchor sleeve DuoPower ETA 8 und 10

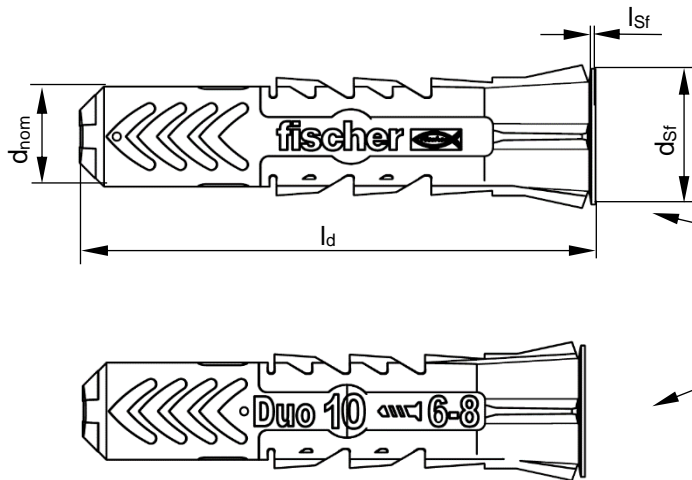

Marking:

Brand

Anchor type

Size

Screw diameter

e.g. fischer  Duo 10  6-8

e.g. fischer  Duo 8  4,5-6

Figure not to scale

**fischer universal plug DuoPower ETA**

**Product description**

Anchor sleeve types  
Marking and dimensions

**Annex A 2**

Annex 5 / 14

## fischer PowerFast II

### Countersunk screw

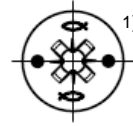
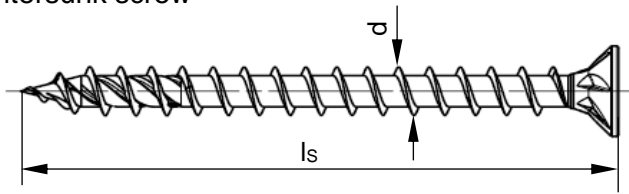

### Raised countersunk head screw

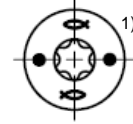
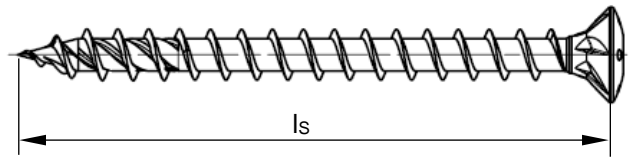

### Pan head screw

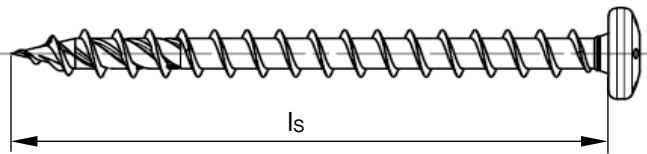

1) Internal driving feature for Torx bit or cross recess bit for all head shapes.

## Special screws

### Countersunk screw

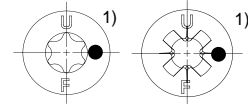
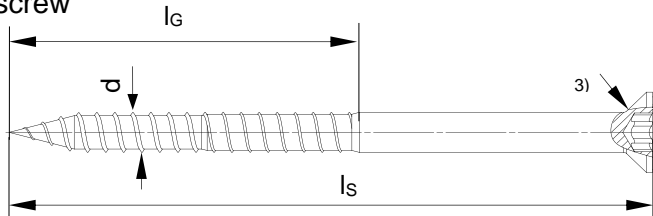

### Hexagonal screw with washer

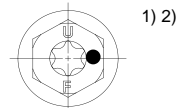
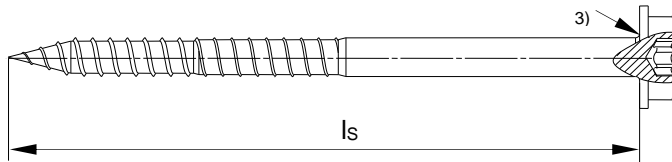

### Hexagonal screw

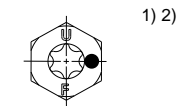
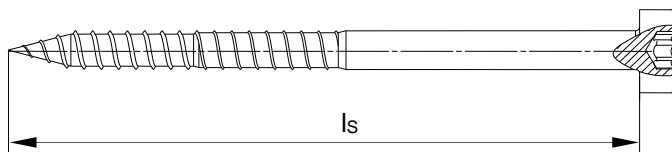

- 1) Additional marking for the special screw, stainless steel version: e.g. "A4" or "R" or "A2".
- 2) Internal driving feature for Torx bit is optional for hexagonal head.
- 3) Optional additional version with underhead ribs.

Figure not to scale

## fischer universal plug DuoPower ETA

### Product description

fischer PowerFast II and special screws  
Marking and dimensions

## Annex A 3

Annex 6 / 14

**Table A4.1: Dimensions of the anchor type with fischer PowerFast II**

Anchor type	Anchor sleeve						fischer PowerFast II	
	$h_{nom}$ [mm]	$d_{nom}$ [mm]	$t_{fix}$ [mm]	$l_d$ [mm]	$l_{sf}$ [mm]	$d_{sf}$ [mm]	$d$ [mm]	$l_s$ [mm]
DuoPower ETA 8x40	40	8	$\geq 1$	40	0,4	11,0	6,0	$\geq l_d + t_{fix} + 6$

**Table A4.2: Dimensions of the anchor type with special screw**

Anchor type	Anchor sleeve						special screw	
	$h_{nom}$ [mm]	$d_{nom}$ [mm]	$t_{fix}$ [mm]	$l_d$ [mm]	$l_{sf}$ [mm]	$d_{sf}$ [mm]	$d$ [mm]	$l_s$ [mm]
DuoPower ETA 8x40	40	8	$\geq 1$	40	0,4	11,0	6,0	$\geq l_d + t_{fix} + 6$
DuoPower ETA 10x50	50	10	$\geq 1$	50	0,4	13,0	7,0	$\geq l_d + t_{fix} + 7$

**Table A4.3: Materials**

Name	Material
Anchor sleeve	Polyamide, PA6, colour grey Polypropylene PP, colour red
fischer PowerFast II	- Galvanised steel gvz with Zn5/Ag or Zn5/An in accordance with EN ISO 4042 <u>or</u> - Galvanised steel gvz with Zn5/Ag or Zn5/An in accordance with EN ISO 4042 with additional organic layer (Zn5/Ag/T7 or Zn5/An/T7, resp.) in three layers (total layer thickness $\geq 6 \mu\text{m}$ )
Screw	- Galvanised steel gvz with Zn5/Ag or Zn5/An in accordance with EN ISO 4042 <u>or</u> - Galvanised steel gvz with Zn5/Ag or Zn5/An in accordance with EN ISO 4042 with additional organic layer (Zn5/Ag/T7 or Zn5/An/T7, resp.) in three layers (total layer thickness $\geq 6 \mu\text{m}$ ) <u>or</u> - Stainless steel "A2" of corrosion resistance class CRC II in accordance with EN 1993-1-4 <u>or</u> - Stainless steel "A4" or "R" of corrosion resistance class CRC III in accordance with EN 1993-1-4

**fischer universal plug DuoPower ETA**

**Product description**  
Dimensions and materials

**Annex A 4**

Annex 7 / 14



## Specifications of intended use

### Anchorage subject to:

- Static and quasi-static loads.
- Multiple fastening of non-structural systems.

### Base materials:

- Reinforced or unreinforced compacted normal weight concrete without fibres, strength classes  $\geq$  C12/15, base material group "a", in accordance with EN 206, see Annex C 2.
- Solid brick masonry, base material group "b", as per EN 771-1 or EN 771-2, see Annex C 3.  
Note: The characteristic resistance is also valid for larger brick sizes and higher compressive strength of the masonry unit.
- Mortar strength class of masonry  $\geq$  M2,5 in accordance with EN 998-2.
- For other comparable base materials of the base material group "a" or "b", the characteristic resistance of the anchor may be determined by job site tests in accordance with TR 051.

### Temperature Range:

- a: - 20 °C to 40 °C (max. short term temperature + 40 °C and max. long term temperature + 24 °C).

### Use conditions (Environmental conditions):

- Structures subject to dry internal conditions: fischer PowerFast II of zinc coated steel or special screw made of zinc coated steel or stainless steel.
- Structures subject to external atmospheric exposure (including industrial and marine environment) and to permanently damp internal condition, if no particular aggressive conditions exist: Special screw made of stainless steel of corrosion resistance class CRC III.
- Note: Particular aggressive conditions are e.g. permanent, alternating immersion in seawater or the splash zone of seawater, chloride atmosphere of indoor swimming pools or atmosphere with extreme chemical pollution (e.g. in desulphurization plants or road tunnels where de-icing materials are used).

### Design:

- The anchorages are designed in accordance with TR 064 under the responsibility of an engineer experienced in anchorages and masonry work.
- Verifiable calculation notes and drawings shall be prepared taking account of the loads to be anchored, the nature and strength of the base materials and the dimensions of the anchorage members as well as of the relevant tolerances. The position of the anchor is indicated on the design drawings.
- Fasteners are only to be used for multiple use for non-structural application in accordance with TR 064.

### Installation:

- Hole drilling by the drilling method according to Annex C 2 and C 3 for base material group "a" und "b".
- Anchor installation carried out by appropriately qualified personnel and under the supervision of the person responsible for technical matters of the site.
- Installation temperature from -5 °C to +40 °C.
- Exposure to UV due to solar radiation of the anchor not protected  $\leq$  6 weeks.
- No ingress of water in the borehole at temperatures  $<$  0 °C.

**fischer universal plug DuoPower ETA**

**Intended use**  
Specifications

**Annex B 1**

Annex 8 / 14

**Table B2.1: Installation parameters**

Anchor type		DuoPower ETA 8x40	DuoPower ETA 10x50
Drill hole diameter	$d_0 =$ [mm]	8	10
Cutting diameter of drill bit	$d_{cut} \leq$ [mm]	8,45	10,45
Overall plastic anchor embedment depth in the base material <sup>1)</sup>	$h_{nom} \geq$ [mm]	40	50
Depth of drill hole to deepest point <sup>1)</sup>	$h_1 \geq$ [mm]	$l_s - t_{fix} + 10$	$l_s - t_{fix} + 10$
Diameter of clearance hole in the fixture	$d_f \leq$ [mm]	6,5	7,5

<sup>1)</sup> See Annex A 1.

**Table B2.2: Minimum thickness of member, edge distances and spacings in concrete, base material group “a”**

Anchor type	Embedment depth $h_{nom}$ [mm]	Concrete strength class [-]	Min. thickness of member $h_{min}$ [mm]	Characteristic edge distance $c_{cr,N}$ [mm]	Characteristic spacing $s_{cr,N}$ [mm]	Min. spacing and edge distances <sup>1)</sup> $c_{min}, s_{min}$ [mm]
DuoPower ETA 8x40 with fischer PowerFast II	40	C12/15	150	80	25	$s_{min}=70$ für $c \geq 140$ $c_{min}=70$ für $s \geq 140$
		$\geq C16/20$		55	15	$s_{min}=50$ für $c \geq 100$ $c_{min}=50$ für $s \geq 100$
DuoPower ETA 8x40 with special screw	40	C12/15	150	130	70	$s_{min}=70$ für $c \geq 140$ $c_{min}=115$ für $s \geq 230$
		$\geq C16/20$		90	50	$s_{min}=50$ für $c \geq 100$ $c_{min}=80$ für $s \geq 160$
DuoPower ETA 10x50 with special screw	50	C12/15	150	115	70	$s_{min}=70$ für $c \geq 140$ $c_{min}=115$ für $s \geq 230$
		$\geq C16/20$		80	50	$s_{min}=50$ für $c \geq 100$ $c_{min}=80$ für $s \geq 160$

<sup>1)</sup> Intermediate values by linear interpolation.

Fixing points with a spacing  $a \leq s_{cr}$  are considered as a group with a max. characteristic resistance  $N_{RK,p}$  acc. to Table C 2.1. For a spacing  $a > s_{cr}$  the anchors are considered as single anchors, each with a characteristic resistance  $N_{RK,p}$  acc. to Table C 2.1.

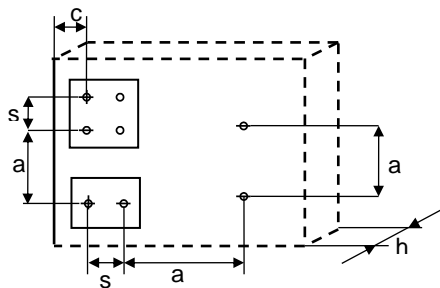

**Scheme of distances and spacings in concrete, base material group “a”**

Figure not to scale

**fischer universal plug DuoPower ETA**

**Intended use**

Installation parameters  
Minimum thickness of member, edge distances and spacings for use in concrete

**Annex B 2**

Annex 9 / 14

**Table B3.1: Minimum thickness of member, edge distance and spacing in solid masonry, base material group “b”**

Anchor type			DuoPower ETA 10x50
Screw type		[-]	special screw
Minimum thickness of member <sup>1)</sup>	$h_{min}$	[mm]	115
Minimum spacing between anchor groups and / or single anchors	$a_{min}$	[mm]	250
<b>Single anchor</b>			
Minimum edge distance	$c_{min}$	[mm]	80
<b>Anchor group</b>			
Minimum spacing perpendicular to free edge	$s_{1,min}$	[mm]	50
Minimum spacing parallel to free edge	$s_{2,min}$	[mm]	50
Minimum edge distance	$c_{min}$	[mm]	80

<sup>1)</sup> Member thickness in accordance to Annex C 3.

**Scheme of distances and spacings in solid masonry, base material group “b”**

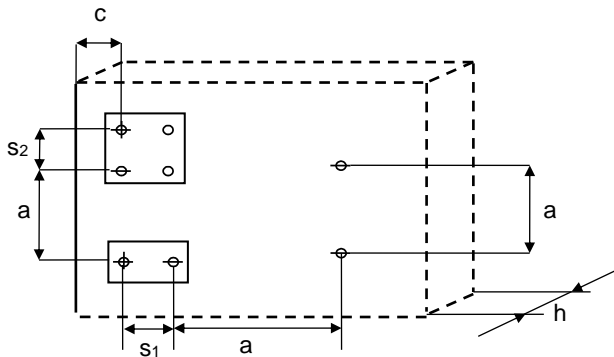

Figure not to scale

**fischer universal plug DuoPower ETA**

**Intended use**

Minimum thickness of member, edge distances and spacings for use in solid masonry

**Annex B 3**

Annex 10 / 14

## Installation instructions

The following pictures show a fastening by a timber fixture part, exemplarily on the substrate concrete for solid masonry – summary of all kind of masonry bricks see Annex C 3.

### Concrete and solid bricks

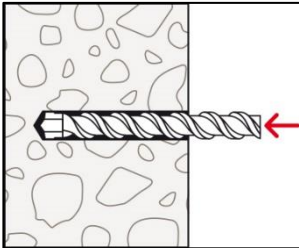

1. Drill the bore hole acc. to Table B 2.1 using the drilling method hammer drilling.

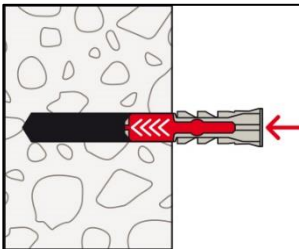

2. Insert anchor by using a hammer until the collar of the plastic sleeve is flush with the surface of the anchorage ground.

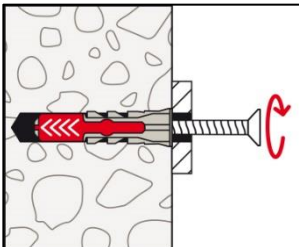

3. Attach fixture part and screw in the screw.  
The anchor is correctly mounted, when the head of the screw fits tight on the surface and cannot be screwed-in easily any further.

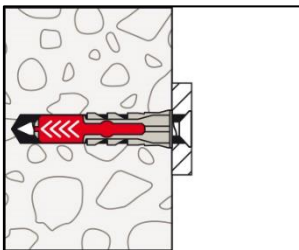

4. Correctly installed anchor.

fischer universal plug DuoPower ETA

Intended use  
Installation instructions

Annex B 4

Annex 11 / 14

**Table C1.1: Characteristic resistance of the screw fischer PowerFast II**

Failure of expansion element (fischer PowerFast II)	DuoPower ETA 8x40	
	galvanised steel	
Characteristic tension resistance $N_{Rk,s}$ [kN]	13,10 <sup>1)</sup>	
Partial safety factor $\gamma_{Ms}^{2)}$ [-]	1,40	
Characteristic shear resistance $V_{Rk,s}$ [kN]	6,50	
Partial safety factor $\gamma_{Ms}^{2)}$ [-]	1,50	
Characteristic bending resistance of the screw		
Characteristic bending resistance $M_{Rk,s}$ [Nm]	8,20	
Partial safety factor $\gamma_{Ms}^{2)}$ [-]	1,50	

<sup>1)</sup> Value based on ETA-19/0175.

<sup>2)</sup> In absence of other national regulations.

**Table C1.2: Characteristic resistance of the special screw**

Failure of expansion element (special screw)	DuoPower ETA 8x40		DuoPower ETA 10x50	
	galvanised steel	stainless steel	galvanised steel	stainless steel
Characteristic tension resistance $N_{Rk,s}$ [kN]	14,80	14,30	21,70	21,70
Partial safety factor $\gamma_{Ms}^{1)}$ [-]	1,50	1,55	1,55	1,55
Characteristic shear resistance $V_{Rk,s}$ [kN]	7,40	7,10	10,80	10,80
Partial safety factor $\gamma_{Ms}^{1)}$ [-]	1,25	1,29	1,29	1,29
Characteristic bending resistance of the screw				
Characteristic bending resistance $M_{Rk,s}$ [Nm]	12,40	12,00	20,60	20,60
Partial safety factor $\gamma_{Ms}^{1)}$ [-]	1,25	1,29	1,29	1,29

<sup>1)</sup> In absence of other national regulations.

**fischer universal plug DuoPower ETA**

**Performances**

Characteristic resistance and characteristic bending resistance of the fischer PowerFast II and the special screw

**Annex C 1**

Annex 12 / 14

**Table C2.1: Characteristic resistance due to pull-out failure for use in concrete, base material group "a"<sup>1)</sup>**

Pull-out failure (plastic sleeve)		DuoPower ETA 8x40		DuoPower ETA 10x50
Screw type		fischer PowerFast II	special screw	special screw
Embedment depth $h_{nom}$ [mm]		40	40	50
<b>Concrete C12/15</b>				
Characteristic tension resistance 24/40 °C	$N_{Rk,p}$ [kN]	0,21	1,40	1,40
<b>Concrete <math>\geq</math> C16/20</b>				
Characteristic tension resistance 24/40 °C	$N_{Rk,p}$ [kN]	0,30	2,00	2,00
Partial safety factor	$\gamma_{Mc}^{2)}$ [-]	1,8		

<sup>1)</sup> Drilling method: hammer drilling.

<sup>2)</sup> In absence of other national regulations.

**Table C2.2: Displacements under tension and shear loading in concrete**

Displacements under			Tension load <sup>1)</sup>		Shear load <sup>1)</sup>	
Anchor type	$h_{nom}$ [mm]	F [kN]	$\delta_{N0}$ [mm]	$\delta_{N\infty}$ [mm]	$\delta_{v0}$ [mm]	$\delta_{v\infty}$ [mm]
DuoPower ETA 8x40 with fischer PowerFast II	40	0,08	0,01	0,02	0,07	0,10
		0,12	0,01	0,02	0,10	0,15
DuoPower ETA 8x40 with special screw	40	0,56	0,09	0,15	0,47	0,70
		0,79	0,13	0,15	0,66	0,99
DuoPower ETA 10x50 with special screw	50	0,56	0,07	0,21	0,32	0,48
		0,79	0,10	0,21	0,45	0,68

<sup>1)</sup> Intermediate values by linear interpolation.

**Table C2.3: Displacements under tension and shear loading in solid bricks**

Displacements under				Tension load <sup>1)</sup>		Shear load <sup>1)</sup>	
Anchor type	$h_{nom}$ [mm]	Base material	F [kN]	$\delta_{N0}$ [mm]	$\delta_{N\infty}$ [mm]	$\delta_{v0}$ [mm]	$\delta_{v\infty}$ [mm]
DuoPower ETA 10x50 with special screw	50	Clay brick Mz; $\rho \geq 2,0$ as per EN 771-1	0,40	0,05	0,21	0,23	0,34
			0,71	0,09	0,21	0,41	0,61
		Calcium silicate solid brick KS; $\rho \geq 2,0$ as per EN 771-2	0,60	0,07	0,21	0,34	0,52
			0,86	0,10	0,21	0,49	0,74

<sup>1)</sup> Intermediate values by linear interpolation.

**fischer universal plug DuoPower ETA**

**Performances**

Characteristic resistance for use in concrete

Displacements under tension and shear loading in concrete and masonry

**Annex C 2**

Annex 13 / 14

**Table C3.1: Characteristic resistance  $F_{Rk}$  in [kN] for use in solid bricks, base material group „b“<sup>(1)</sup>**

<b>Base material</b> by specifying the bulk density [kg/dm <sup>3</sup> ] <i>[Supplier Title, country]</i> Geometry, DF or nominal. size L x B x H [mm] and drilling method	Mean compressive strength / Min. compressive strength single brick as per EN 771 [N/mm <sup>2</sup> ]	Characteristic resistance $F_{Rk}$ [kN] Temperature range 24/40 °C
		DuoPower ETA 10x50 with special screw
		$h_{nom}$ [mm] = 50
<b>Clay brick Mz; <math>\rho \geq 2,0</math></b> as per EN 771-1 <i>e.g. Helfer, DE</i> <b>NF 240x115x71</b> Hammer drilling	12,5/10	<b>1,40</b>
	15/12	<b>1,40</b>
	20/16	<b>2,00</b>
	25/20	<b>2,50</b>
	25,32/-	<b>2,50</b>
<b>Calcium silicate solid brick KS; <math>\rho \geq 2,0</math></b> as per EN 771-2 <i>e.g. Bayer, DE</i> <b>2 DF 240x115x113</b> Hammer drilling	10/8	<b>2,10 / 2,45<sup>3)</sup></b>
	12,5/10	<b>2,10 / 2,45<sup>3)</sup></b>
	15/12	<b>2,10 / 2,45<sup>3)</sup></b>
	16,7/-	<b>3,00 / 3,50<sup>3)</sup></b>
Partial safety factor	$\gamma_{Mm}$ <sup>2)</sup> [-]	<b>2,5</b>

- 1) Vertically perforation  $\leq 15\%$ ; cross section reduced by perforation vertically to the resting area.  
 2) In absence of other national regulations.  
 3) Only valid for  $c_{1min}$  110 mm and  $c_{2min}$  165 mm.

**fischer universal plug DuoPower ETA**

**Performances**

Characteristic resistance for use in solid bricks

**Annex C 3**