

SUORITUSTASOILMOITUS

DoP 0324

fischer termoz SV II ecotwist eristeikiinnike (Muoviankkurit käytettäväksi betonissa ja muuratuissa rakenteissa)

FI

- | | | |
|---|--|---|
| 1. <u>Tuotetyypin yksilöllinen tunnistus:</u> | DoP 0324 | |
| 2. <u>Aiottu käyttötarkoitus (aiotut käyttötarkoitukset):</u> | Ruuvattava nailonankkuri ulkoisten lämmöneristyskomposiittijärjestelmien (ETICS) kiinnittämiseen betoniin ja muurattuun rakenteeseen., katso lisäys, erityisesti liitteet B1 - B3. | |
| 3. <u>Valmistaja:</u> | fischerwerke GmbH & Co. KG, Klaus-Fischer-Str. 1, 72178 Waldachtal, Saksa | |
| 4. <u>Valtuutettu edustaja:</u> | - | |
| 5. <u>Suoritustason pysyvyyden arvioinnissa ja varmentamisessa käytetty järjestelmä/käytetyt järjestelmät:</u> | 2+ | |
| 6. <u>Eurooppalainen arviointiasiakirja:</u>
Eurooppalainen tekninen arviointi:
Teknisestä arvioinnista vastaava laitos:
Ilmoitettu laitos/ilmoitetut laitokset: | EAD 330196-01-0604, Edition 10/2017
ETA-12/0208; 2022-10-18
DIBt- Deutsches Institut für Bautechnik
2873 TU Darmstadt | |
| 7. <u>Ilmoitettu suoritustaso/ilmoitetut suoritustasot:</u>
Käyttöturvallisuus (BWR 4)
Tyypillinen kantavuus: | Tyypillinen vastus vetokuormituksessa:
Pienin reunaetäisyys:
Pienin keskinäinen etäisyys: | Liite C1
Liite B2
Liite B2 |
| Siirtymät: | Vetokuorma osittaisella kertoimella:
Siirtymät: | Liite C2
Liite C2 |
| Levyn jäykkyys: | Ankkurilevyn halkaisija:
Ankkurilevyn kuormituskestävyys:
Levyn jäykkyys: | NPD
NPD
NPD |
| Energialoudellisuus ja lämmönkesto (BWR 6)
Lämmönläpäisykyky: | Pistekohtainen lämmönläpäisykerroin:
ETICS:n eristyskerroksen paksuus: | Liite C2
Liite C2 |
| 8. <u>Asianmukainen tekninen asiakirja ja/tai tekninen erityisasiakirja:</u> | - | |

Edellä yksilöidyn tuotteen suoritustaso on ilmoitettujen suoritustasojen joukon mukainen. Tämä suoritustasoilmoitus on asetuksen (EU) N:o 305/2011 mukaisesti annettu edellä ilmoitetun valmistajan yksinomaisella vastuulla.

Valmistajan puolesta allekirjoittanut:



Dr.-Ing. Oliver Geibig, Toimitusjohtaja Liiketoimintayksikkö & Suunnittelu
Tumlingen, 2022-10-31



Jürgen Grün, Toimitusjohtaja Kemia & Laatu

Tämä suoritustasoilmoitus on laadittu useilla kielillä. Jos tulkinnasta syntyy erimielisyyttä, englanninkielinen versio on aina katsottava ensisijaiseksi.

Lisäys sisältää vapaaehtoisesti ilmoitettua ja täydentävää englanninkielistä tietoa, joka ylittää (kielestä riippumatta määritellyt) lakisäätöiset vaatimukset.

Specific part

1 Technical description of the product

The fischer TermoZ SV II Ecotwist screwed-in anchor consist of an anchor sleeve and a screw plate in different colours, both made of polyamide (virgin material) and an accompanying specific screw of galvanised steel.

The product description is given in Annex A.

2 Specification of the intended use in accordance with the applicable European Assessment Document

The performances given in Section 3 are only valid if the anchor is used in compliance with the specifications and conditions given in Annex B.

The verification and assessment methods on which this European Technical Assessment is based lead to the assumption of a working life of the anchor of at least 25 years. The indications given on the working life cannot be interpreted as a guarantee given by the producer, but are to be regarded only as a means for choosing the right products in relation to the expected economically reasonable working life of the works.

3 Performance of the product and references to the methods used for its assessment

3.1 Safety and accessibility in use (BWR 4)

Essential characteristic	Performance
Characteristic load bearing capacity <ul style="list-style-type: none">- Characteristic resistance under tension load- Minimum edge distance and spacing	See Annex C 1 See Annex B 2
Displacements	See Annex C 2
Plate stiffness	No performance assessed

3.2 Energy economy and heat retention (BWR 6)

Essential characteristic	Performance
Point thermal transmittance	See Annex C 2

4 Assessment and verification of constancy of performance (AVCP) system applied, with reference to its legal base

In accordance with EAD No. 330196-01-0604, the applicable European legal act is: [97/463/EC].

The system to be applied is: 2+

TermoZ SV II Ecotwist

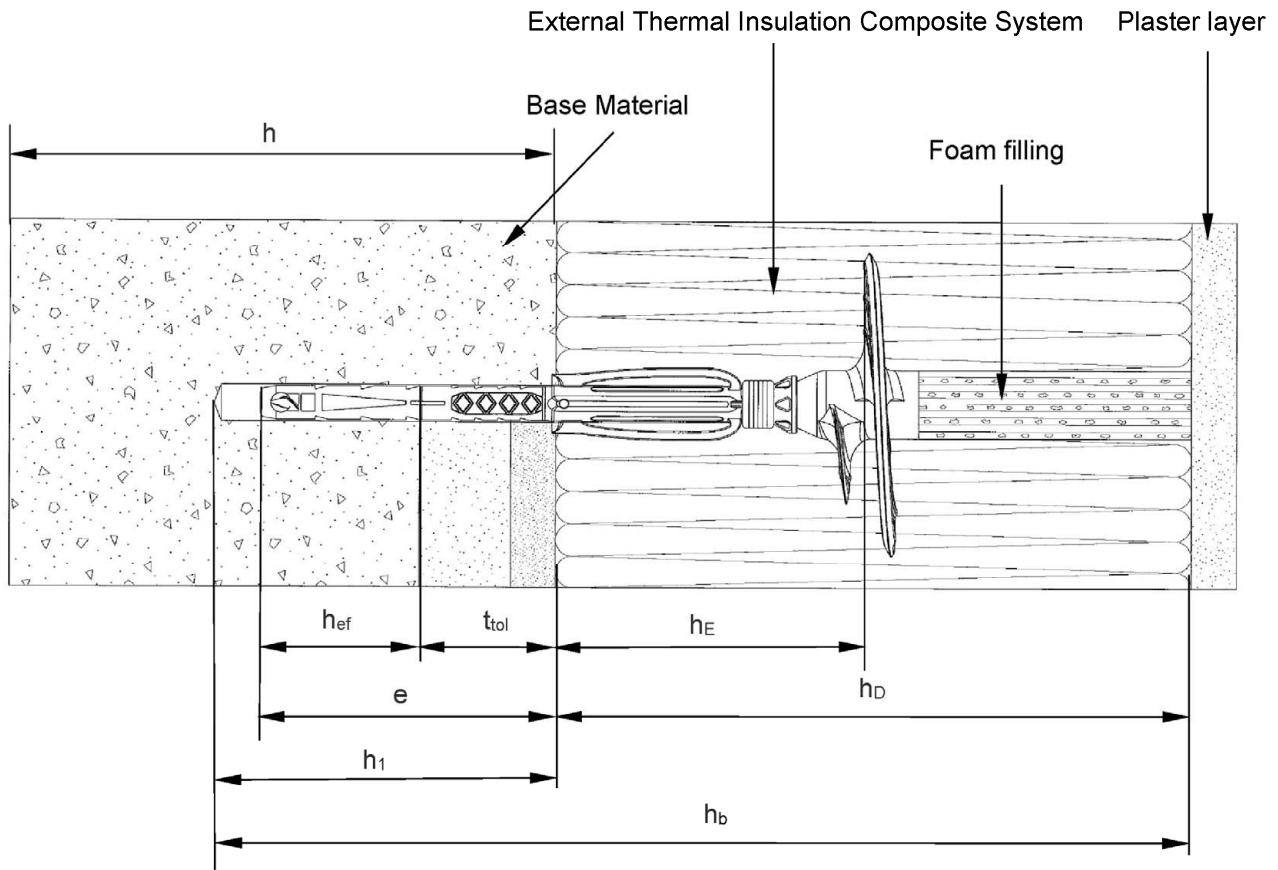

Legend

- h_1 = Depth of drilled hole to deepest point in the base material
- h = Thickness of base material (wall)
- h_D = Thickness of insulation material
- t_{tol} = Thickness of equalising layer and / or non-load bearing coating
- h_E = Embedment depth
- h_b = Total bore hole depth
- h_{ef} = Effective anchor embedment depth in the base material
- e = Effective anchor embedment depth in the base material including thickness of equalising layer and / or non-load bearing coating

Figure not to scale

fischer TermoZ SV II Ecotwist

Product description
Installed anchor

Annex A 1

Appendix 2 / 9

TermoZ SV II Ecotwist

Anchor sleeve

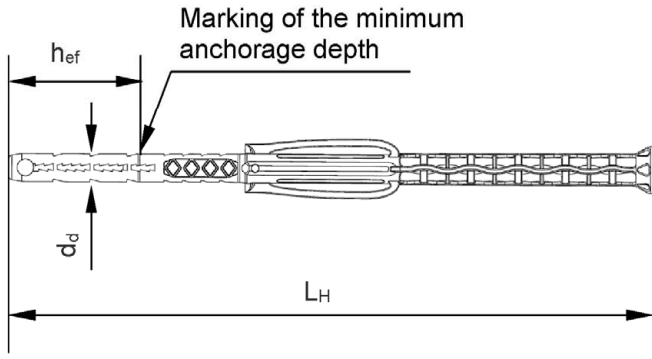

Screw plate

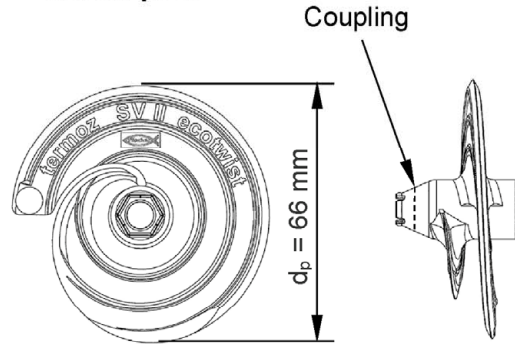

Special screw

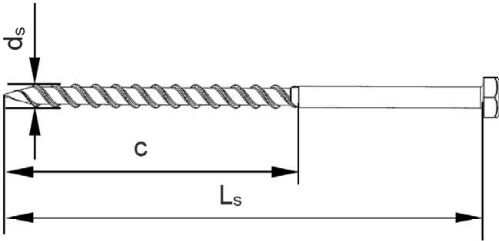

Adjustment of the ring depends on the insulation material thickness, e.g. $h_D = 180 \text{ mm}$
 → adjust value 180 at the setting tool

Setting tool

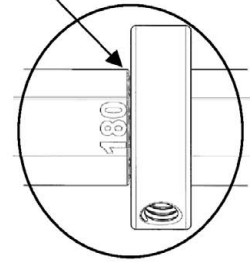
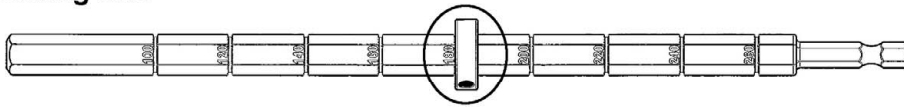

Complete Anchor

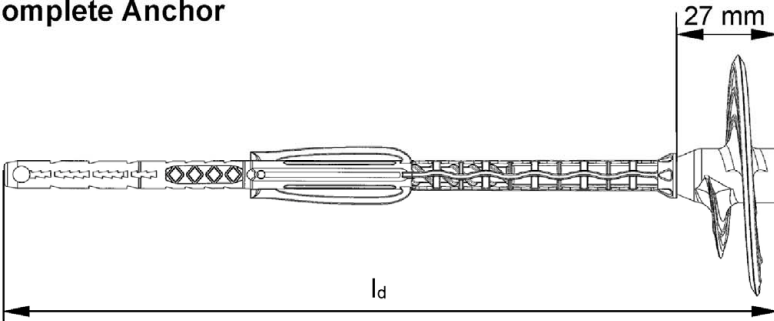

Figures not to scale

fischer TermoZ SV II Ecotwist

Product description
 Anchor type and single parts

Annex A 2

Appendix 3 / 9

Table A3.1: Dimensions

Anchor type	Anchor sleeve					Special screw		
	d_d	$h_{er}^{(1)}$	$h_E^{(1)}$	l_d	L_H	d_s	L_s	c
TermoZ SV II Ecotwist	[mm]							
	8	35	70	162	135	6	100	74
				202	175		120	
				232	205		150	

¹⁾ see Annex A 1.

Table A3.2: Marking on the screw plate

Anchor type	Marking
Name	termoz SV II ecotwist
Works symbol	

Table A3.2: Marking on the anchor sleeve

Anchor type	Marking
TermoZ SV II Ecotwist t_{tol} 0-10 mm	t_{tol} 0 - 10
TermoZ SV II Ecotwist t_{tol} 0-30 mm	t_{tol} 0 - 30
TermoZ SV II Ecotwist t_{tol} 30-60 mm	t_{tol} 30 - 60

Table A3.2: Material

Designation	Material
Anchor sleeve	PA6, colour: grey
Screw plate	PA6 GF, colour: grey, yellow, red, orange, green, blue, mocca-latte, black
Special screw	Galvanised steel gvz with Zn5/Ag or Zn5/An in accordance with EN ISO 4042
Insulation plug	Polystyrene, mineral wool

fischer TermoZ SV II Ecotwist

Product description

Dimensions anchor types, marking on the screw plate/anchor sleeve
Material

Annex A 3

Appendix 4 / 9

Specifications of intended use

Anchorage subject to:

- The anchor may only be used for transmission of wind suction loads and shall not be used for the transmission of dead loads of the external thermal insulation composite system.

Base materials:

- Normal weight concrete without fibres \geq C12/15 (base material group "A") as per EN 206, see Annex C 1.
- Solid masonry (base material group "B") as per EN 771-1, EN 771-2 or EN 771-3, see Annex C 1.
- Hollow or perforated masonry (base material group "C") as per EN 771-1, EN 771-2 or EN 771-3, see Annex C 1.
- Lightweight aggregate concrete (base material group "D") as per EN 1520, see Annex C 1.
- Autoclaved aerated concrete (base material group "E") as per EN 771-4, see Annex C 1.
- For other base materials of the base material groups "A", "B", "C", "D" and "E" the characteristic resistance of the anchor may be determined by job site tests in accordance with EOTA Technical Report TR 051.

Temperature Range:

- 0 °C to + 40 °C (max. short term temperature + 40 °C and max. long term temperature + 24 °C) of the base material.

Design:

- The anchorages are designed under the responsibility of an engineer experienced in anchorages and masonry work with the partial safety factors for material related resistances $\gamma_M = 2,0$ and for action loads $\gamma_F = 1,5$ in absence of other national regulations.
- Verifiable calculation notes and drawings are prepared taking account of the loads to be anchored. The position of the anchors is indicated on the design drawings.
- Fasteners are only to be used for multiple fixings of external thermal insulation composite systems.

Installation:

- Drilling method according to Annex C 1.
- Anchor installation carried out by appropriately qualified personnel and under the supervision of the person responsible for technical matters on the site.
- Installation temperature from 0 °C to + 40 °C.
- Exposure to UV due to solar radiation of the anchor not protected by rendering \leq 6 weeks.

fischer TermoZ SV II Ecotwist

Intended use
Specifications

Annex B 1

Appendix 5 / 9

Table B2.1: Installation parameters in all regulated base material groups

Anchor type		TermoZ SV II Ecotwist
Drill hole diameter	$d_0 = [\text{mm}]$	8
Cutting diameter of drill bit	$d_{\text{cut}} \leq [\text{mm}]$	8,45
Depth of drill hole to deepest point		
TermoZ SV II Ecotwist t_{tol} 0-10 mm	$h_1 \geq [\text{mm}]$	55
TermoZ SV II Ecotwist t_{tol} 0-30 mm	$h_1 \geq [\text{mm}]$	75
TermoZ SV II Ecotwist t_{tol} 30-60 mm	$h_1 \geq [\text{mm}]$	105
Total bore hole depth at		
TermoZ SV II Ecotwist t_{tol} 0-10 mm	$h_b \geq [\text{mm}]$	$h_D + 55$
TermoZ SV II Ecotwist t_{tol} 0-30 mm	$h_b \geq [\text{mm}]$	$h_D + 75$
TermoZ SV II Ecotwist t_{tol} 30-60 mm	$h_b \geq [\text{mm}]$	$h_D + 105$
Overall plastic anchor embedment depth in the base material including equalising layers / coatings ($h_{\text{ef}} + t_{\text{tol,max}}$) ¹⁾		
TermoZ SV II Ecotwist t_{tol} 0-10 mm	$e = [\text{mm}]$	45
TermoZ SV II Ecotwist t_{tol} 0-30 mm	$e = [\text{mm}]$	65
TermoZ SV II Ecotwist t_{tol} 30-60 mm	$e = [\text{mm}]$	95

¹⁾ see Annex A 1.

Table B2.2: Minimum thickness of member, edge distances and spacing in all regulated base material groups

Anchor type		TermoZ SV II Ecotwist
Minimum thickness of member	$h_{\text{min}} = [\text{mm}]$	100 ¹⁾
Minimum spacing	$s_{\text{min}} = [\text{mm}]$	100
Minimum edge distance	$c_{\text{min}} = [\text{mm}]$	100

¹⁾ For weather resistant external wall panels: $h_{\text{min}}=40$ mm.

Scheme of edge distances and spacing
for base material group “A”, concrete,
group “B” solid bricks, group “C” hollow or
perforated masonry, group “d” lightweight
aggregate concrete, group “E” autoclaved
aerated concrete

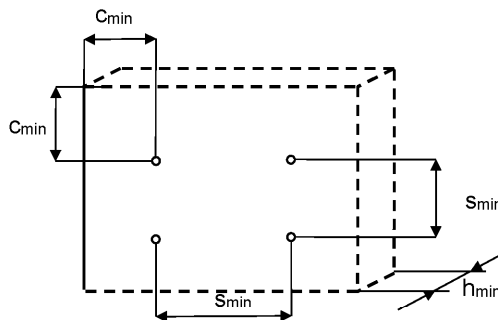

Figure not to scale

fischer TermoZ SV II Ecotwist

Intended use
Installation Parameters
Minimum thickness of member, edge distances and spacing

Annex B 2

Appendix 6 / 9

Installation instructions

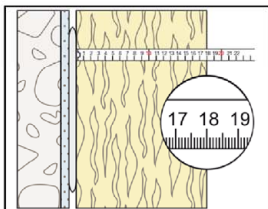

1. Measure insulation thickness h_D (example: 18 cm = 180 mm).

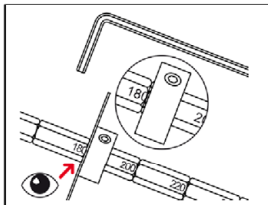

2. Adjust the setting tool ring corresponding to the insulation material thickness h_D in mm. Number is legible. Additionally to the setting tool ring, a thin plastic plate (maximum 1 mm thickness) can be used as a stop unit for easier mounting.

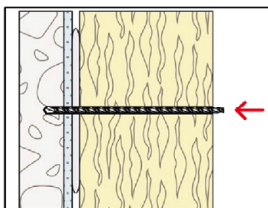

3. Drill bore hole. Total drill hole depth must be at
 $t_{tol} 0-10 \text{ mm} \rightarrow h_D + 55 \text{ mm}$
 $t_{tol} 0-30 \text{ mm} \rightarrow h_D + 75 \text{ mm}$
 $t_{tol} 30-60 \text{ mm} \rightarrow h_D + 105 \text{ mm}.$
Note: bore holes in Hlz and autoclaved aerated concrete only by rotary drilling.

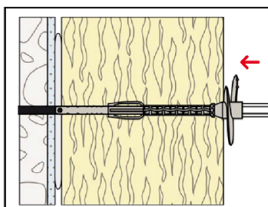

4. Press the anchor with the screw plate tight against the surface of the insulation material, then start screwing-in the anchor. Setting is finished when the surface of the ring is flush with the surface of the insulation material.

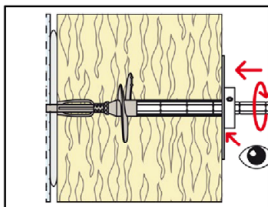

5. After reaching the setting depth, press the adjustment tool tight against the installed anchor. If there is no axial movement of the anchor, remove the setting tool. The setting process is finished.

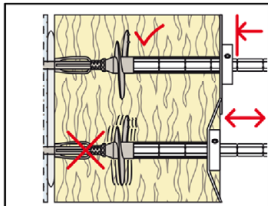

6. In case of axial movement, a new anchor has to be set in a new drill hole.

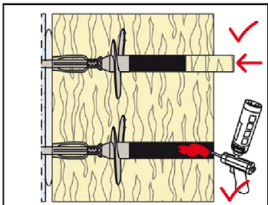

7. The hole in the insulation material must be filled with a suitable foam (illustrated in Annex A 1) or must be closed with an appropriate insulation plug.

fischer TermoZ SV II Ecotwist

Intended use
Installation instructions

Annex B 3

Appendix 7 / 9

Table C1.1: Characteristic resistance to tension load N_{Rk} for a single anchor TermoZ SV II Ecotwist

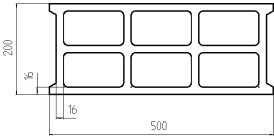
Base material	Group	Bulk density ρ [kg/dm ³]	Mean compressive strength / minimum compressive strength single brick as per EN 771 ⁴⁾ [N/mm ²]	Remarks	Drilling method ¹⁾	Characteristic resistance to tension load N_{Rk} [kN]
Weather resistant skin of external wall panels, concrete C20/25 - C50/60 as per EN 206	A	-	-	Thickness of concrete panels 40 mm ≤ h < 100 mm.	H	0,90
					R	1,50
Concrete C12/15 - C50/60 as per EN 206	A	-	-	-	H	1,50
Solid clay bricks, Mz as per EN 771-1	B ²⁾	≥ 1,8	15/12	-	H	1,20
Sand-lime solid bricks, KS as per EN 771-2	B ²⁾	≥ 2,0	15/12	-	H	1,20
			25/20			1,50
Solid concrete block, Vbn as per EN 771-3	B ²⁾	≥ 2,0	15/12	-	H	1,20
			25/20			1,50
Lightweight concrete solid blocks, Vbl as per EN 771-3	B ²⁾	≥ 1,4	10/8	-	H	0,60
Vertically perforated clay bricks, Hlz as per EN 771-1	C ³⁾	≥ 1,0	15/12	Exterior web thickness ≥ 12 mm.	R	0,75
Vertically perforated sand-lime bricks, KSL as per EN 771-2	C ³⁾	≥ 1,4	15/12	Exterior web thickness ≥ 23 mm.	H	0,75
			25/20			1,20
Lightweight concrete hollow blocks, Hbl as per EN 771-3	C ³⁾	≥ 1,2	5/4	Exterior web thickness ≥ 38 mm.	H	0,60
			7,5/6			0,75
			10/8			0,90
			12,5/10			1,20
French lightweight concrete hollow block, Hbl as per EN 771-3 "Sepa Parpaing" 500 x 200 x 190 mm	C ³⁾	≥ 0,9	5/4	 <p>Web thickness ≥ 16 mm.</p>	H	0,50
Lightweight aggregate concrete, LAC as per EN 1520	D ³⁾	≥ 0,9	7,5/6	Minimum thickness of solid brick h = 100 mm or exterior web thickness ≥ 50 mm.	H	0,75
Autoclaved aerated concrete, AAC as per EN 771-4	E	≥ 0,5	5/4	-	R	0,40

¹⁾ H = Hammer drilling, R = Rotary drilling.

²⁾ Vertically perforation ≤ 15%; cross section reduced by perforation vertically to the resting area.

³⁾ Vertically perforation > 15 % and ≤ 50 %, cross section reduced by perforation vertically to the resting area.

⁴⁾ The compressive strength of the single brick must not be less than 80% of the mean compressive strength.

fischer TermoZ SV II Ecotwist

Performances

Characteristic resistance to tension load for single anchor

Annex C 1

Appendix 8 / 9

Table C2.1: Point thermal transmittance according to EOTA Technical Report TR 025

Anchor type	Thickness of insulation material h_D [mm]	Point thermal transmittance χ [W/K]
TermoZ SV II Ecotwist EPS-plug and air void $t_{tol} = 0-10$ mm	100 - 240	0,001
	> 240	0
TermoZ SV II Ecotwist PU-foam filled hole $t_{tol} = 0-10$ mm	100 - 150	0,001
	> 150	0
TermoZ SV II Ecotwist EPS-plug and air void $t_{tol} = 0-30$ mm	100 - 240	0,001
	> 240	0
TermoZ SV II Ecotwist PU-foam filled hole $t_{tol} = 0-30$ mm	100 - 150	0,001
	> 150	0
TermoZ SV II Ecotwist EPS-plug and air void $t_{tol} = 30-60$ mm	100	0,002
	120 - 240	0,001
	> 240	0
TermoZ SV II Ecotwist PU-foam filled hole $t_{tol} = 30-60$ mm	100	0,002
	120 - 150	0,001
	> 150	0

Table C2.2: Displacements for TermoZ SV II Ecotwist

Base material		Mean compressive strength / minimum compressive strength single brick as per EN 771 ¹⁾ [N/mm ²]	Tension load N [kN]	Displacements $\Delta\delta_N$ [mm]
Concrete, thin members C20/25 - C50/60 as per EN 206	Hammer drilling	-	0,30	< 0,30
	Rotary drilling	-	0,50	< 0,30
Concrete, C16/20 - C50/60 as per EN 206		-	0,50	< 0,30
Clay bricks, Mz as per EN 771-1		15/12	0,40	< 0,30
Sand-lime solid bricks, KS as per EN 771-2		15/12	0,40	< 0,30
		25/20	0,50	
Solid concrete block, Vbn as per EN 771-3		15/12	0,40	< 0,30
		25/20	0,50	
Lightweight concrete solid blocks, Vbl as per EN 771-3		10/8	0,20	< 0,20
Vertically perforated clay bricks, Hlz as per EN 771-1		15/12	0,25	< 0,30
Vertically perforated sand-lime bricks, KSL as per EN 771-2		15/12	0,25	< 0,20
		25/20	0,40	
Lightweight concrete hollow blocks, Hbl as per EN 771-3		5/4	0,20	< 0,30
		7,5/6	0,25	
		10/8	0,30	
		12/10	0,40	
Lightweight concrete hollow blocks, Hbl as per EN 771-3		5/4	0,15	< 0,40
Lightweight aggregate concrete, LAC as per EN 1520		7,5/6	0,25	< 0,20
Autoclaved aerated concrete blocks, AAC as per EN 771-4		5/4	0,15	< 0,10

¹⁾ The compressive strength of the single brick must not be less than 80% of the mean compressive strength.

fischer TermoZ SV II Ecotwist

Performances

Point thermal transmittance

Displacements

Annex C 2

Appendix 9 / 9