

SUORITUSTASOILMOITUS

DoP 0364

fischer Zykon-paneeliankkurille ZYKON FZP II T D40 PA (for Atlas)

FI

- Tuotetyypin yksilöllinen tunniste:** DoP 0364
- Aiottu käyttötarkoitus (aiotut käyttötarkoitukset):** Kiinnikeankkurit keraamisten "Atlas" julkisivupaneelien takakiinnitykseen, katso lisäys, erityisesti liitteet B1 - B6.
- Valmistaja:** fischerwerke GmbH & Co. KG, Klaus-Fischer-Str. 1, 72178 Waldachtal, Saksa
- Valtuutettu edustaja:** -
- Suoritusasteen pysyvyyden arvioinnissa ja varmentamisessa käytetty järjestelmä/käytetyt järjestelmät:** 2+
- Eurooppalainen arviointiasiakirja:** EAD 330030-00-0601
Eurooppalainen tekninen arviointi: ETA-23/0035; 2023-01-24
Teknisestä arvioinnista vastaava laitos: ETA-DANMARK A/S
Ilmoitettu laitos/ilmoitetut laitokset: 2873 TU Darmstadt
- Ilmoitettu suoritusaste/ilmoitetut suoritusastot:**
Mekaaninen kestävyys ja vakaus (BWR 1)
Ominainen vastustus vetokuorman johdosta aiheutuvaan rikkoutumiseen tai irtoamiseen: Liite C1
Ominainen vastustus leikkauskuorman johdosta aiheutuvaan rikkoutumiseen tai irtoamiseen: Liite C1
Ominainen vastustus yhdistetyn veto- ja leikkauskuorman johdosta aiheutuvaan rikkoutumiseen tai irtoamiseen: Liite C1 Y=NPD; F_{Rk}=NPD

Reuna- ja väljetäisyys: Liitteet B3, C1
Kestävyys: Liite A3, B1
Ominainen vastustus veto- ja leikkauskuorman johdosta aiheutuviin metallivaurioihin: NPD

Paloturvallisuus (BWR 2)
Reagointi tuleen: Class (A1)
- Asianmukainen tekninen asiakirja ja/tai tekninen erityisasiakirja:** -

Edellä yksilöidyn tuotteen suoritusaste on ilmoitettujen suoritusasteiden joukon mukainen. Tämä suoritusasteilmoitus on asetuksen (EU) N:o 305/2011 mukaisesti annettu edellä ilmoitetun valmistajan yksinomisella vastuulla.

Valmistajan puolesta allekirjoittanut:



Dr.-Ing. Oliver Geibig, Toimitusjohtaja Liiketoimintayksikkö & Suunnittelu
Tumlingen, 2024-06-03



Jürgen Grün, Toimitusjohtaja Kemia & Laatu

Tämä suoritusasteilmoitus on laadittu useilla kielillä. Jos tulkinnasta syntyy erimielisyyttä, englanninkielinen versio on aina katsottava ensisijaiseksi.

Lisäys sisältää vapaaehtoisesti ilmoitettua ja täydentävää englanninkielistä tietoa, joka ylittää (kielestä riippumatta määritellyt) lakisäätöiset vaatimukset.

II SPECIFIC PART OF THE EUROPEAN TECHNICAL ASSESSMENT

1 Technical description of product

The fischer ZYKON FZP II T D40 PA for fixing Atlas Concorde facade panels is a special anchor made of stainless steel, consisting of an anchor with M6 external thread, an expansion part, a shim washer and a hexagonal nut. The anchor is put into an undercut drill hole and by pressing down the shim washer, the expansion ring is deformed by the cone bolt. Due to this process, a stress-free fixing is created, caused by the geometrical interlocking of the undercut anchor and undercut drill hole..

The Atlas Concorde facade panels are made from ceramic tiles in accordance with EN 14411 and have the following characteristics:

	Values
E-Module [N/mm ²], mean	30000
Thermal Expansion (µm/mK)	6,6 µm/mK
5% Fractile bending resistance, characteristic	45 N/mm ²
Density [g/cm ³], nominal	2,55
Frost resistance	Yes

For the installed anchor see figure in Annex A1.

2 Specification of the intended use in accordance with the applicable European Assessment Document (hereinafter EAD)

The fischer ZYKON FZP II T D40 PA are intended for fixing Atlas Concorde facade panels for which requirements for mechanical resistance and stability in the sense of the Basic Works Requirements 1 of Regulation 305/2011 shall be fulfilled. The façade panels shall correspond to the drawings and specifications of this European Technical Assessment. The intended use specifications of the product are detailed in the Annex B1.

The façade panels with rear fixing by the anchor may only be used for rear ventilated front curtain walls. Each façade panel shall be fixed technically strain-free with at least four anchors in a rectangular arrangement via single agraffes on a capable substructure (for small panels or small fitted pieces, differential or fill- in pieces the number and position of the anchors shall be chosen constructively).

The anchor may be used in structures subject to dry internal conditions and also in structures subject to external atmospheric exposure (including industrial and marine environment), if no particular aggressive conditions exist. Such particular aggressive conditions are e.g. permanent, alternating immersion in seawater or the splash zone of seawater, chloride atmosphere of indoor swimming pools or atmosphere with extreme chemical pollution (e.g. in desulphurisation plants or road tunnels where de-icing materials are used).

The provisions made in this European Technical Assessment are based on an assumed working life of the anchor of 50 years.

The indications given on the working life cannot be interpreted as a guarantee given by the producer or Assessment Body, but are to be regarded only as a means for choosing the right products in relation to the expected economically reasonable working life of the works.

3 Performance of the product and references to the methods used for its assessment

Characteristic	Assessment of characteristic
3.1 Mechanical resistance and stability (BWR1)	
Characteristic load bearing capacity and displacements	The anchor corresponds to the drawings and specifications given in Annex A2-A3. The characteristic material values, dimensions and tolerances of the anchor not indicated in Annex A2-A3 shall correspond to the respective values laid down in the technical documentation of this European Technical Assessment.
<ul style="list-style-type: none">• Characteristic resistance to breakout or pull-out failure under tension load• Characteristic resistance to breakout or pull-out failure under shear load• Edge distance and spacing• Characteristic resistance to steel failure under tension and shear load	The characteristic values for the design of the façade panels with rear fixing by the anchor are given in Annex C1.
Characteristic resistance to breakout or pull-out failure under combined tension and shear load	No performance assessed
Durability	The anchors are made from stainless steel (material no. 1.4401, 1.4571 or 1.4404) corresponding to corrosion resistance class (CRC) III in EN 1993-1-4 table A.3.
3.2 Safety in case of fire (BWR2)	
Reaction to fire	The anchors are made from steel classified as Euroclass A1 in accordance with EN 13501-1 and Commission Delegated Regulation 2016/364

4 Attestation and verification of constancy of performance (AVCP)

4.1 AVCP system

According to the decision 97/161/EC the European Commission, the system(s) of assessment and verification of constancy of performance (see Annex V to Regulation (EU) No 305/2011) is 2+.

Installed fastener

Figure A1:

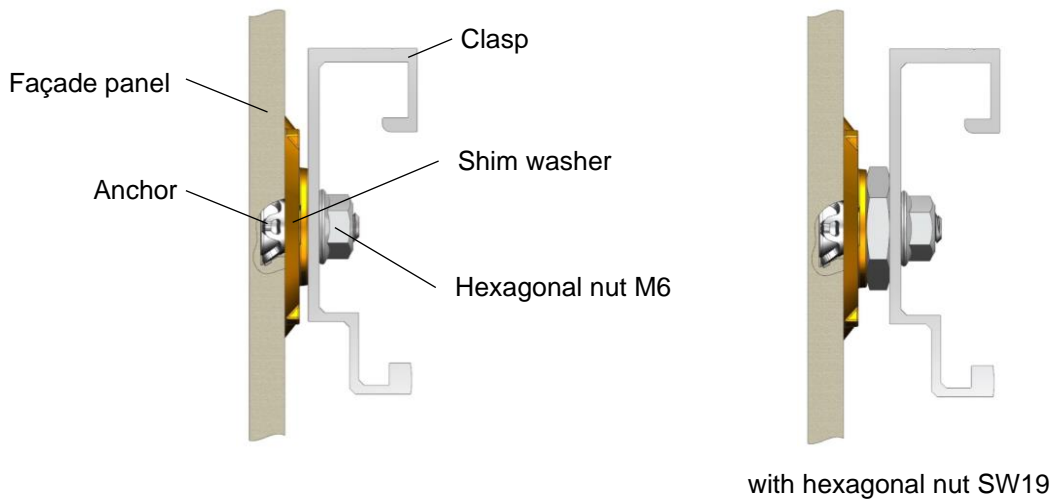

Example of façade panel on substructure

Figure A2:

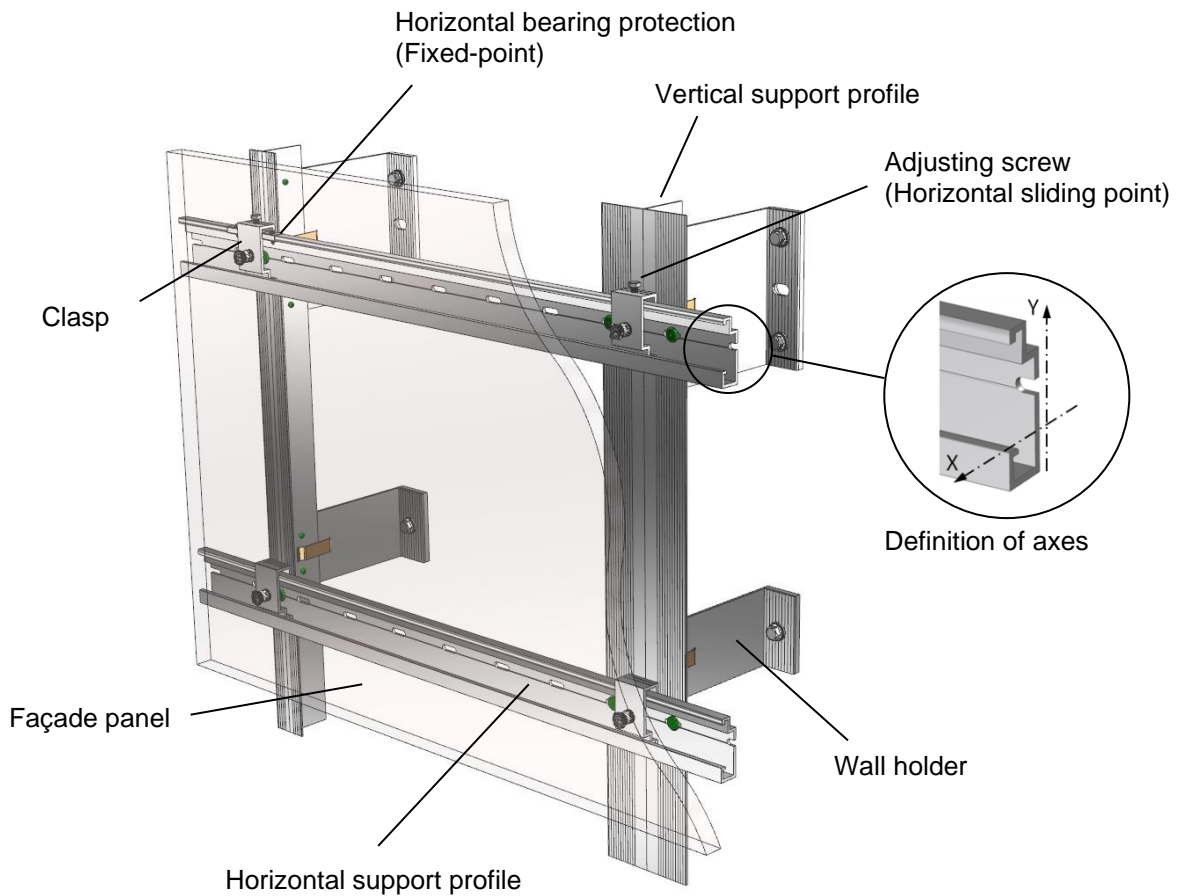

fischer Zykon panel anchor FZP II T D40 PA

Product description
Installed anchoring and fixing example

Annex A 1

Appendix 4 / 13

Type of anchor

Anchor with external thread M6

Figure A3:

**Undercut anchor
FZP II T D40 PA**

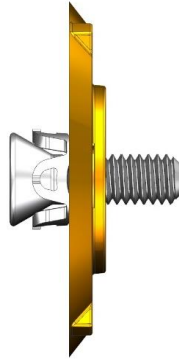

with hexagonal nut

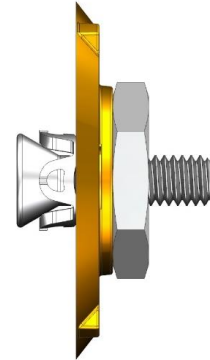

Type of mounting

Figure A4:

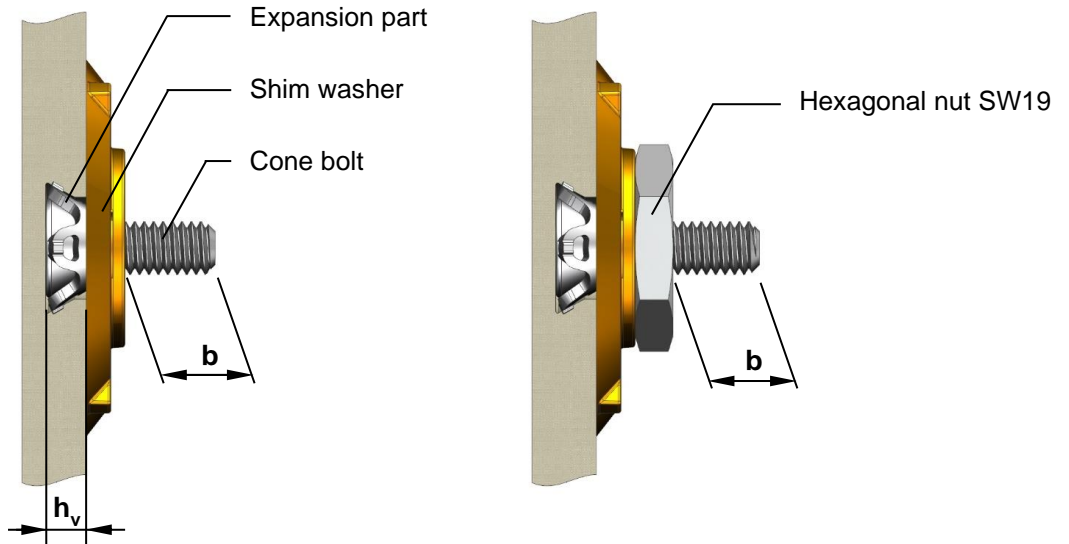

Identification system

FZP II 11 x 5 M6 / T / 10 D40 PA

- Shim washer made of polyamide (Al = Aluminum hexagonal nut)
- Free thread length **b** after mounting
- Thin materials
- Thread diameter
- Drill hole depth **h_v** (for FZP II T $h_v = h_1 = h_s =$ Embedment depth)
- \varnothing cylindrical diameter **d₀**
- Fischer Zykon (Cylindrical conical) **Panel anchor II**

fischer Zykon panel anchor FZP II T D40 PA

Product description

Type of anchor, built-in state and identification system

Annex A 2

Parts of anchor and materials

Cone bolt external thread M6 (Optional: UNC thread)

Figure A5:

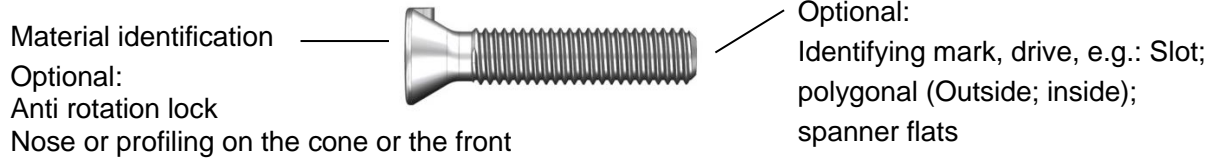

Expansion part

For cone bolts with external thread M6

Figure A6:



Shim washer

For cone bolts with external thread M6

Figure A7:

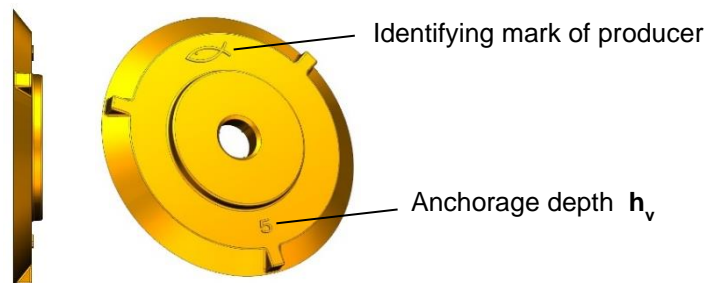

Hexagonal nut

For cone bolts with external thread M6

Figure A8:

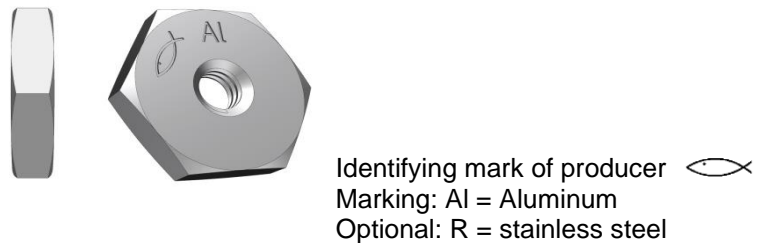

Table A1: Material of anchor parts

Anchor parts	Material
Cone bolt	Stainless steel, EN 10088 :2014
Expansion part	Stainless steel, EN 10088 :2014
Shim washer	Polyamide 6.6
Hexagonal nut	Aluminum, EN 755:2016 Stainless steel, EN 10088 :2014

fischer Zykon panel anchor FZP II T D40 PA

Product description
Parts of anchor and material

Annex A 3

Appendix 6 / 13

Specifications of intended use

Anchorage subject to:

- Static and quasi-static loads.

Use conditions (Environmental conditions):

- According to the corrosion resistance class (CRC) according to EN 1993-1-4:2015 (ETA Section 3.1)

Anchorage ground:

- The Atlas Concorde façade panels shall be in accordance with EN 14411:2016 "Ceramic tiles – definition, classification, characteristics, assessment and verification of constancy of performance and marking". The Atlas Concorde façade panels have to meet the requirements of group BI_a according to EN 14411:2016.
- The characteristic values of the façade panels correspond to Annex B2, Table B1.

Design:

- The design of anchorages under static and quasistatic load is carried out in accordance with the specifications of the façade panel manufacturer.
- The façade panels, their fixings as well as the substructure including its connection to wall brackets and their connection to the construction works are designed for the respective case of application under the responsibility of an engineer skilled in the field of façade construction.
- Verifiable calculation notes and drawings shall be prepared taking account of the loads to be anchored, the nature and strength of the base materials and the dimensions of the anchorage members as well as of the relevant tolerances. The position of the anchor is indicated on the design drawings.
- Each façade panel is fixed with at least four anchors in a rectangular arrangement via single clasps or panel support profiles on the substructure. For small panels or small fitted pieces, differential or fill- in pieces the number and position of the anchors shall be chosen constructively.
- Edge distance and spacing shall be observed. For small panels, differential and fitted pieces, the edge and axial spacing shall be chosen constructively.
- The substructure is constructed such that the façade panels are fixed technically strain-free via skids (loose bearings) and one fixed point (fixed bearing). The fixed point may be placed at the panel edge or in the panel field.
- Two fixing points of the façade panel are designed such that they are able to carry the dead load of the façade panel.
- When using clasps on horizontal support profiles, the horizontal fixing points of a facade panel at the same height must each be fixed to the same support profile.

fischer Zykon panel anchor FZP II T D40 PA

Intended use
Specifications

Annex B 1

Appendix 7 / 13

Table B1: Characteristic values of façade panels – geometrical and physical properties

Trade name		Atlas Concorde
Country of origin		Italy
Maximum panel size	L x H or H x L [mm]	1198 x 2398
Nominal panel thickness	$h_{nom} =$ [mm]	9
Panel thickness (minimum)	$h_{min} =$ [mm]	8,5
Panel thickness (maximum)	$h_{max} =$ [mm]	9,5
Dead load	$g_k =$ [kN/m ²]	0,225
Specific weight	$\gamma =$ [kN/m ³]	25,0
Density - dry	$\rho \geq$ [g/cm ³]	2,55
Modulus of elastic	$E_{mean} =$ [N/mm ²]	30000
Poisson ratio	$\nu =$ [-]	0,2
Coefficient of thermal expansion	$\alpha_T =$ [10 ⁻⁶ K ⁻¹]	6,6
Characteristic bending strength	$\sigma_{Rk} =$ [N/mm ²]	45

fischer Zykon panel anchor FZP II T D40 PA

Intended use
Specifications

Annex B 2

Appendix 8 / 13

Installation:

- The drillings are done at the factory or on site under workshop conditions; when making the drillings on site the execution is supervised by the responsible project supervisor or a skilled representative of the project supervisor.
- Making of the undercut drilling is done with a special drill bit or a special CNC drill bit according to Annex B 4 and a special drilling device in accordance with the information deposited with ETA-Danmark A/S.
- The drilling residues are removed from the drill hole.
- In case of aborted hole: new drilling at a minimum distance away of twice the depth of the aborted hole.
- The geometry of the drill hole is checked at least on 5% of all drillings. Checks also need to be performed when using a new drill bit or when the operator changes. The following dimensions shall be checked and documented according to manufacturer's information and testing instructions by means of a control aids according to Annex B5, Figure B5, B6 and B7.
 - Diameter of the cylindrical drill hole.
 - Diameter of the undercut.
 - Drill hole depth.
- If the tolerance given in Annex B 4, Table B2 is exceeded, the geometry of the drill hole shall be checked on 25 % of the drillings performed. No further drill hole should exceed the tolerances otherwise all the drill holes have to be controlled. Drilling holes falling below or exceeding the tolerances shall be rejected.

Note: Checking the geometry of the drill hole on 5% of all drillings means, that on panels with 4 anchor holes, one drill hole on every 5th panel has to be checked. If the tolerances given in Annex B 4 Table B2 are exceeded the extent of the control shall be increase to 25 % of the drillings, i.e. one drilling each shall be checked on all the 5 panels.
- The anchors are installed in a deformation controlled manner. For this purpose suitable installation tools per Annex B 5, Figure B4 shall be used. The anchor is set correctly if the bolt projection "b" as per Annex A2, Figure A4 is observed with its correct value.
- During transport and storage on site the façade panels are protected from damages; the façade panels are not to be hung up jerkily (if need be lifters shall be used for hanging up the façade panels); façade panels and reveal panels respectively with incipient cracks are not be installed.
- The façade panels are arranged in a "reclined" or "upright" position.
- Overhead mounting is permitted (e.g. mounting of ceiling cladding)
- The façade are installed by skilled specialists and the laying instructions of the manufacturer shall be paid attention to.
- The façade panels must not be used for the transmission of impact loads and for the protection against falling.

Figure B1: Definition of edge and centre distance

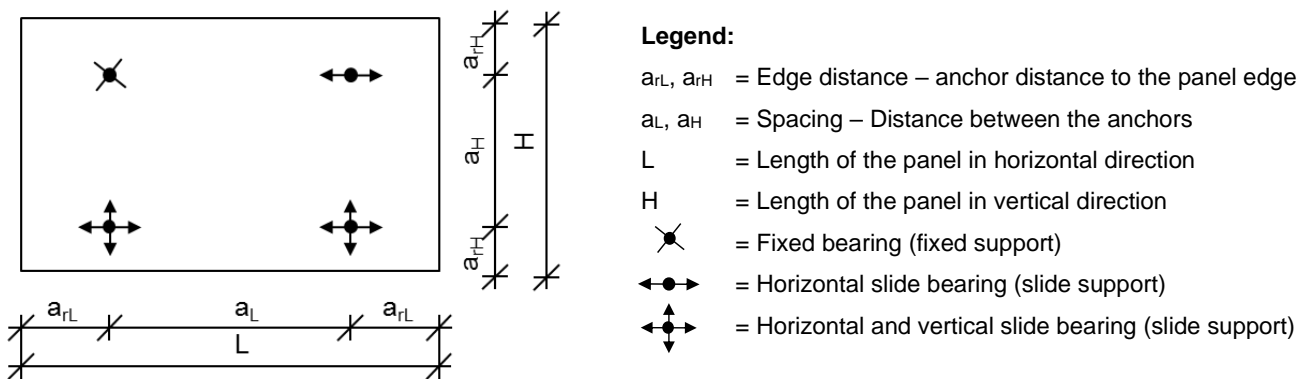

fischer Zykon panel anchor FZP II T D40 PA

Intended use
Installation

Annex B 3

Appendix 9 / 13

Geometry of the drill hole

Figure B2:

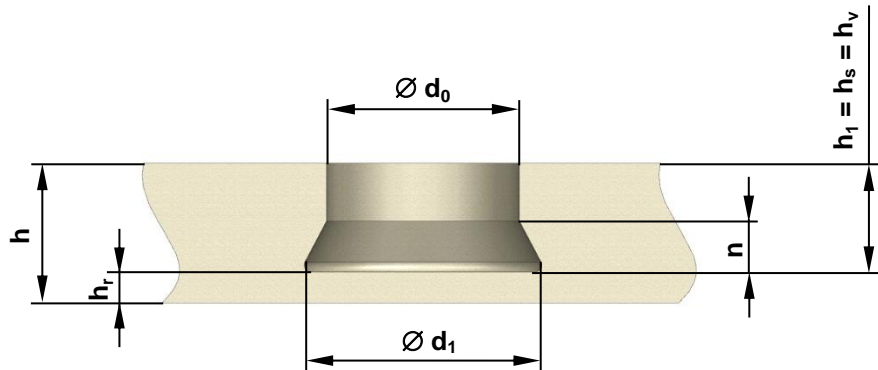

Special drills

Figure B3:

Examples:

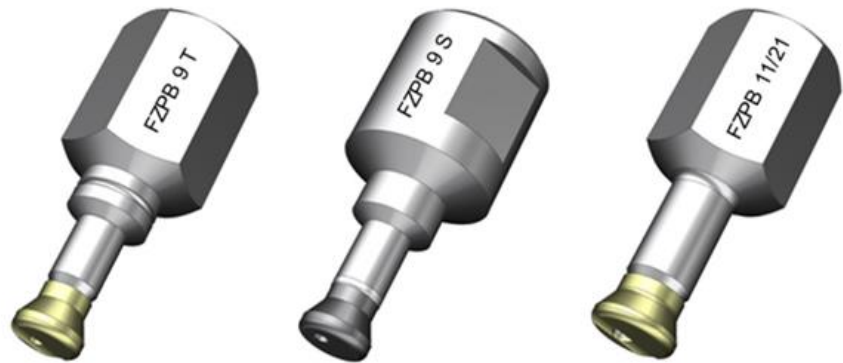

Table B2: Drill hole dimensions [mm]

$\varnothing d_0$	$\varnothing d_1$	h_r *	n	h_v	h_{nom}
$11,2 \pm 0,2$	$13,5 \pm 0,3$	$\approx 4,0$	≈ 4	$5 \begin{matrix} +0,4 \\ -0 \end{matrix}$	$9 \pm 0,5$

* Is to be complied with in case of deviations from h_{nom}

fischer Zykon panel anchor FZP II T D40 PA

Intended use

Drill bit, geometry of the drill hole and installation parameters

Annex B 4

Appendix 10 / 13

Setting tools

Figure B4:



Manual setting tool SGT



Cordless screwdriver with setting tool e.g. SGA or screw socket

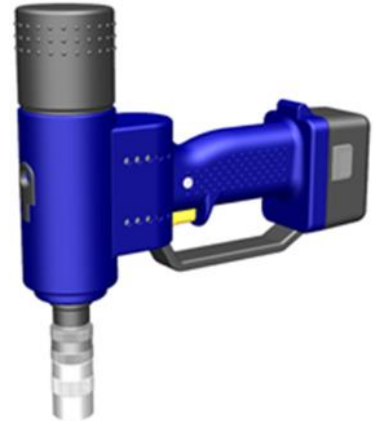

Battery-setting tool SGB

Means for undercut control $\varnothing d_1$

Figure B5:

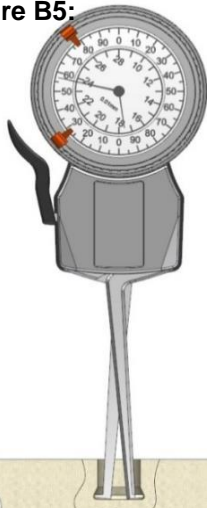

STU (Internal quick test)

Volume gauge

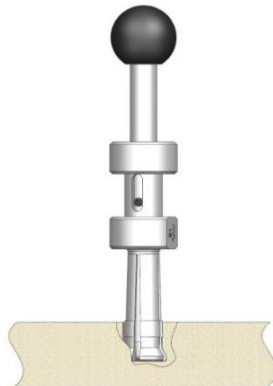

HVL-T (Undercut minimum volume gauge)

Figure B6:

Go / noGo gauge for checking cylindrical drill hole diameter d_0

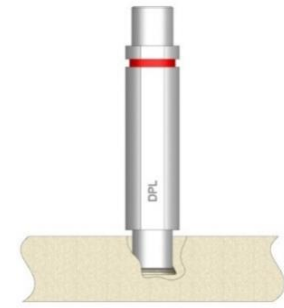

DPL-T (Diameter gauge)

Means for measuring drill hole depth h_1 and drill hole diameter d_0

Figure B7:

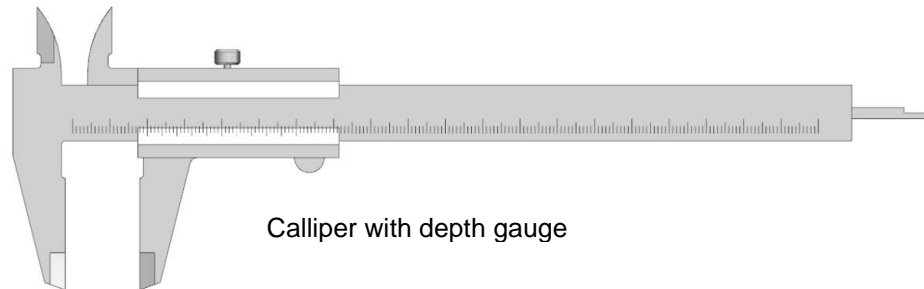

Calliper with depth gauge

fischer Zykon panel anchor FZP II T D40 PA

Intended use
Setting devices and testing equipment

Annex B 5

Appendix 11 / 13

Installation instructions

Example: Set with SGA

1.)



2.)

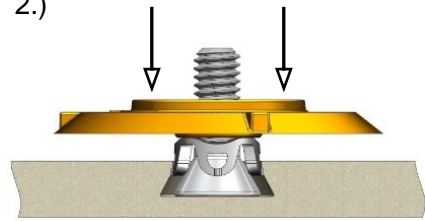

3.)

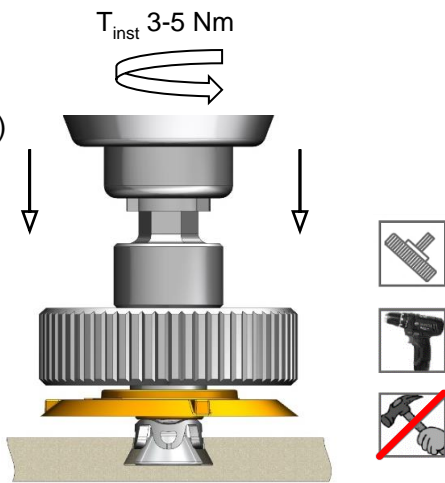

4.)

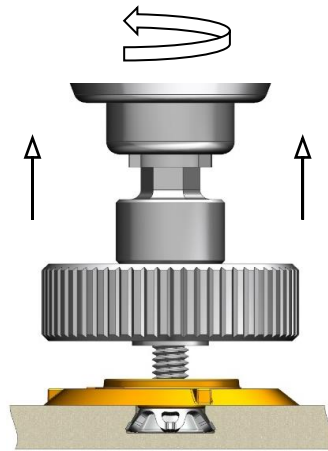

5.1.)

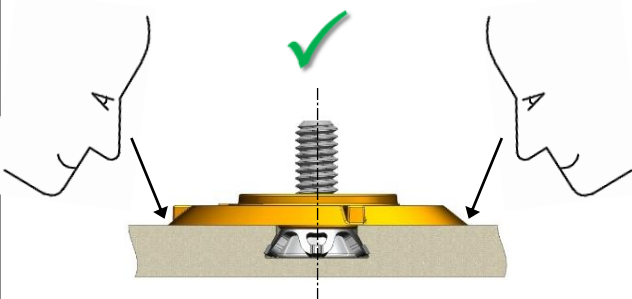

5.2.)

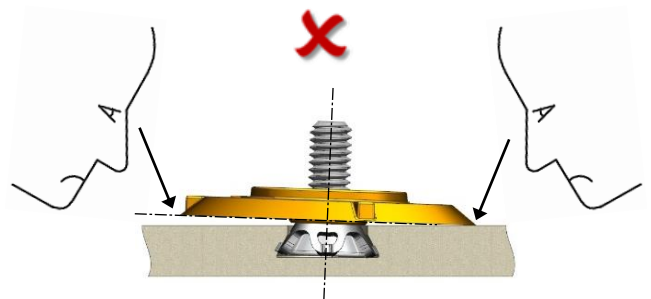

fischer Zykon panel anchor FZP II T D40 PA

Intended use
Installation instructions

Annex B 6

Appendix 12 / 13

Table C1: Characteristic values of anchors and panels

Anchor type			FZP II 11x5 M6/T
Façade panel			Atlas Concorde
Nominal panel thickness	$h_{nom} \geq$	[mm]	9
Embedment depth ²⁾	$h_v =$	[mm]	5
Characteristic resistance ³⁾	Tension load ¹⁾	$N_{Rk} =$	0,75
	Shear load ¹⁾	$V_{Rk} =$	1,95
Trilinear limit	Interaction	$X =$	1
Edge distance	$a_r \geq$	[mm]	100
Spacing	$a \leq$	[mm]	750

1) In case of coincident stress of an anchor due to tension and shear load following equation shall be observed:

$$\frac{N_{Ed}}{N_{Rd}} + \frac{V_{Ed}}{V_{Rd}} \leq 1.0$$

2) For FZP II: anchoring depth $h_v =$ drill hole depth $h_1 =$ embedment depth h_s

3) See annex B1 for additional characteristics of the façade

fischer Zykon panel anchor FZP II T D40 PA

Performances
Characteristic values of anchors

Annex C 1

Appendix 13 / 13