

## SUORITUSTASOILMOITUS

### DoP 0270

fischer kevytbetonianskurille FPX-I (metallinen laajennuksen kiinnittäjä käytettäväksi autoklaavatussa kevytbetonissa)

FI

- Tuotetyypin yksilöllinen tunniste:** DoP 0270
- Aiottu käyttötarkoitus (aiotut käyttötarkoitukset):** Asennuksen jälkeinen kiinnitys käytettäväksi halkeilleissa tai halkeilemattomissa teräsbetonilaatoissa tai kevytbetonista valmistetuissa muurauspaloissa, katso lisäys, erityisesti liitteet B1 - B5.
- Valmistaja:** fischerwerke GmbH & Co. KG, Klaus-Fischer-Str. 1, 72178 Waldachtal, Saksa
- Valtuutettu edustaja:** -
- Suoritustason pysyvyyden arvioinnissa ja varmentamisessa käytetty järjestelmä/käytetyt järjestelmät:** 1
- Eurooppalainen arviointiasiakirja:** EAD 330014-00-0601  
Eurooppalainen tekninen arviointi: ETA-12/0456; 2019-07-19  
Teknisestä arvioinnista vastaava laitos: DIBt- Deutsches Institut für Bautechnik  
Ilmoitettu laitos/ilmoitetut laitokset: 2873 TU Darmstadt
- Ilmoitettu suoritustaso/ilmoitetut suoritustasot:**  
**Mekaaninen kestävyys ja vakaus (BWR 1)**  
Jokaisen kuormasuunnan vastustus ilman konsolia: Liite C1  
Leikkauskuormituksen vastustus konsolin kanssa: Liite C1  
Välitys, reunaetäisyys, paksuus: Liitteet B3, B4, C1  
Siirtymät: Liite C2  
Kestävyys: Liite B1  
  
**Turvallisuus tulipalon sattuessa (BWR 2)**  
Reaktio paloon: Luokka A1  
Palontorjunta jokaisessa kuormasuunnassa ilman konsolia: Liite C2  
Palontorjunta leikkauskuormituksessa konsolin kanssa: NPD  
Välitys ja reunaetäisyys palontorjunnalle: Liite C2
- Asianmukainen tekninen asiakirja ja/tai tekninen erityisasiakirja:** -

Edellä yksilöidyn tuotteen suoritustaso on ilmoitettujen suoritustasojen joukon mukainen. Tämä suoritustasoilmoitus on asetuksen (EU) N:o 305/2011 mukaisesti annettu edellä ilmoitetun valmistajan yksinomaisella vastuulla.

Valmistajan puolesta allekirjoittanut:



Dr.-Ing. Oliver Geibig, Toimitusjohtaja Liiketoimintayksikkö & Suunnittelu  
Tumlingen, 2021-01-15



Jürgen Grün, Toimitusjohtaja Kemia & Laatu

Tämä suoritustasoilmoitus on laadittu useilla kielillä. Jos tulkinnasta syntyy erimielisyyttä, englanninkielinen versio on aina katsottava ensisijaiseksi.

Lisäys sisältää vapaaehtoisesti ilmoitettua ja täydentävää englanninkielistä tietoa, joka ylittää (kielestä riippumatta määritellyt) lakisäätöiset vaatimukset.

## Specific Part

### 1 Technical description of the product

The fischer aircrete anchor FPX-I is a deformation controlled expansion anchor made of galvanised steel. The anchor consists of an internal threaded socket, a cone bolt and an expansion sleeve. The anchor transfers loads into autoclaved aerated concrete via mechanical interlock.

The anchor is set into a predrilled bore hole and anchored with a hexagon installation tool until the installation tool is pushed out of the internal hexagon socket. The fixture is installed with a screw-in part (threaded rods or screw).

The product description is given in Annex A.

### 2 Specification of the intended use in accordance with the applicable European assessment Document

The performances given in Section 3 are only valid if the anchor is used in compliance with the specifications and conditions given in Annex B.

The verifications and assessment methods on which this European Technical Assessment is based lead to the assumption of a working life of the anchor of at least 50 years. The indications given on the working life cannot be interpreted as a guarantee given by the producer, but are to be regarded only as a means for choosing the right products in relation to the expected economically reasonable working life of the works.

### 3 Performance of the product and references to the methods used for its assessment

#### 3.1 Mechanical resistance and stability (BWR 1)

Essential characteristic	Performance
Resistance in any load direction without lever arm	See Annex C 1
Resistance in any load direction with lever arm	See Annex C 1
Spacing, edge distance, member thickness	See Annex B 3 and B 4
Displacements	See Annex C 2
Durability	Durability is ensured if the specifications of intended use according to Annex B are taken into account.

#### 3.2 Safety in case of fire (BWR 2)

Essential characteristic	Performance
Reaction to fire	Class A1
Resistance to fire	See Annex C 2

**4 Assessment and verification of constancy of performance (AVCP) system applied, with reference to its legal base**

In accordance with European Assessment Document EAD No. 330014-00-0601, the applicable European legal act is: [96/582/EC].

The system(s) to be applied is (are): 1

## Product description

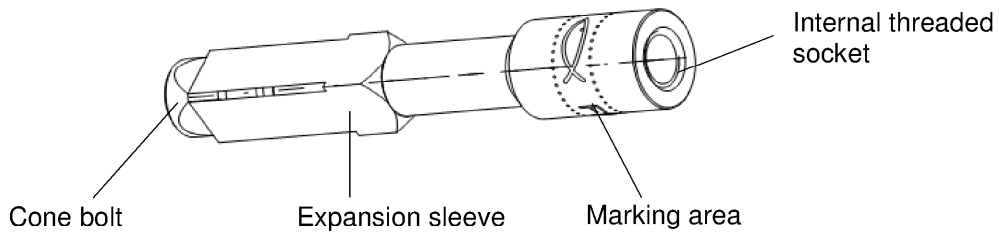

## Product installed

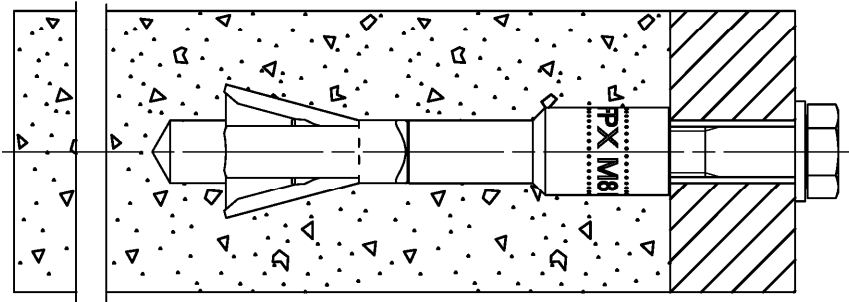

## Product label

Product label, example:

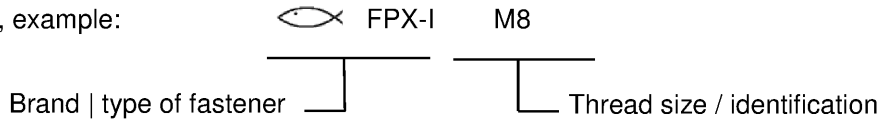

## Product dimensions

**Table A1.1:** Dimension [mm]

Anchor type		FPX-I			
		M6	M8	M10	M12
Internal thread		M6	M8	M10	M12
Anchor length	L =	75			
Diameter head internal threaded socket	$\varnothing D$ =	14			16
Diameter cone bolt	$\varnothing d_c$ =	11			

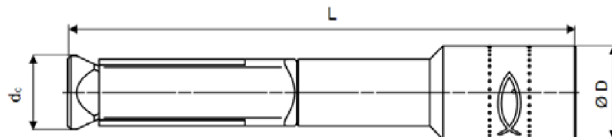

### fischer aircrete anchor FPX-I

#### Product description

Description, label and dimension

## Annex A 1

Appendix 3 / 10

## Specifications of intended use

fischer aircrete anchor FPX-I	M6	M8	M10	M12
Galvanized steel	✓			
Static and quasi-static loads				
Cracked and uncracked Autoclaved Aerated Concrete (AAC)				
Fire exposure in reinforced slabs according to EN 12602:2016 of strength class $f_{AAC} \geq 3,3 \text{ N/mm}^2$ with dry density $\rho_m \geq 0,50 \text{ kg/dm}^3$ and strength class $f_{AAC} \geq 4,4 \text{ N/mm}^2$ with dry density $\rho_m \geq 0,55 \text{ kg/dm}^3$				

### Base material:

- Cracked reinforced slabs (uncracked slabs are included) according to EN 12602:2016 of strength class  $f_{AAC} \geq 3,3 \text{ N/mm}^2$  with dry density  $\rho_m \geq 0,50 \text{ kg/dm}^3$  and strength class  $f_{AAC} \geq 4,4 \text{ N/mm}^2$  with dry density  $\rho_m \geq 0,55 \text{ kg/dm}^3$
- Uncracked reinforced slabs according to EN 12602:2016 of strength class  $f_{AAC} \geq 1,6 \text{ N/mm}^2$  with dry density  $\rho_m \geq 0,25 \text{ kg/dm}^3$  and strength class  $f_{AAC} \geq 6,0 \text{ N/mm}^2$  with dry density  $\rho_m \geq 0,65 \text{ kg/dm}^3$
- Masonry units according to EN 771-4:2011+A1:2015 of strength class  $f_{AAC} \geq 1,6 \text{ N/mm}^2$  with dry density  $\rho_m \geq 0,25 \text{ kg/dm}^3$  and strength class  $f_{AAC} \geq 6,0 \text{ N/mm}^2$  with dry density  $\rho_m \geq 0,65 \text{ kg/dm}^3$
- The mortar strength class of the masonry has to be M 2,5 according to EN 998-2:2017 at minimum

### Use conditions (Environmental conditions):

- Structures subject to dry internal conditions (FPX-I)

### Design:

- Anchorages are to be designed under the responsibility of an engineer experienced in anchorages and concrete and masonry work
- Verifiable calculation notes and drawings are to be prepared taking account in the loads to be anchored. The position of the anchor is to be indicated on the design drawings
- Design of fastenings according to TR 054, Design Method B.

**Table B1.1:** Material

Designation	FPX-I
Cone bolt <sup>1)</sup>	Steel EN 10263:2018
Expansion sleeve <sup>1)</sup>	Steel EN 10277:2018
Internal threaded bolt <sup>1)</sup>	Steel EN 10277:2018
Screw-in-parts <sup>1, 2)</sup>	Minimum steel strength class 4.8, DIN EN ISO 898-1:2013

<sup>1)</sup> Galvanized according to EN ISO 4042:2018,  $\geq 5 \mu\text{m}$

<sup>2)</sup> Screw-in parts (screws and threaded rods including nuts and washer) must comply with the specification in Annex C1.

<b>fischer aircrete anchor FPX-I</b>	<b>Annex B 1</b>  Appendix 4 / 10
<b>Intended use</b> Specifications	

**Table B2.1: Installation parameters**

Size	FPX-I			
	M6	M8	M10	M12
Nominal drill hole diameter	10			
Maximum drill bit diameter	10,45			
Depth of drill hole to deepest point	80			
	95			
Diameter of clearance hole in the fixture	7	9	12	14
Effective embedment depth	70			
Maximum fastening torque <sup>2)</sup>	3			
Screw-in depth internal thread	6	8	10	12
	15			

<sup>1)</sup> For member thickness  $h < 120$  mm the drill hole shall be cleaned and the depth of the drill hole shall be reduced to 80 mm in order to avoid damage on the opposite side of the wall

<sup>2)</sup> If the anchor cannot retain against the fixture no installation torque may be applied ( $T_{max} = 0$  Nm)

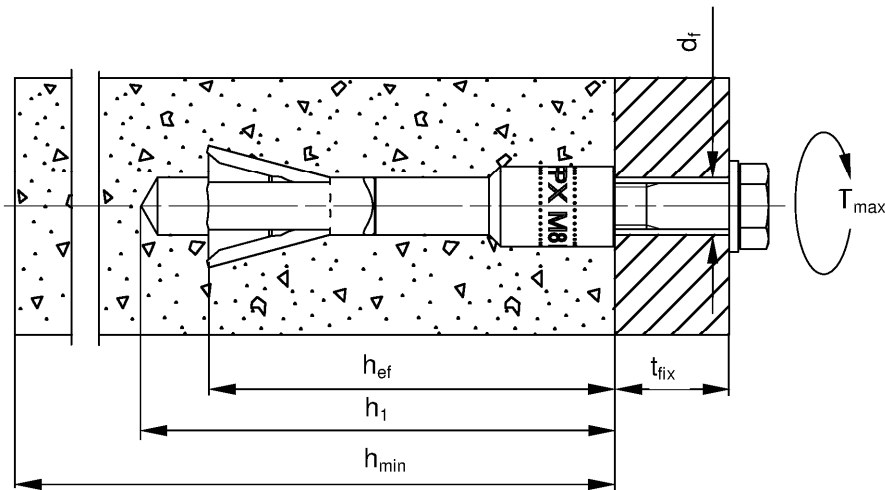

- $h_{ef}$  = Effective embedment depth
- $t_{fix}$  = Thickness of fixture
- $h_1$  = Depth of drill hole to deepest point
- $h_{min}$  = Minimum thickness of AAC member
- $T_{max}$  = Maximum setting torque
- $d_f$  = Diameter of clearance hole in the fixture

**fischer aircrete anchor FPX-I**

**Intended use**  
Installation parameters

**Annex B 2**

Appendix 5 / 10

**Table B3.1: Minimum member thickness, minimum spacing and edge distance in AAC - slabs**

Size	FPX-I							
	M6	M8	M10	M12				
Minimum thickness of AAC - slab					with cleaning <sup>1)</sup>	$h_{min}$	[mm]	100
								without cleaning
Minimum spacing						$s_{min}$	100	
Minimum edge distance					single anchor <sup>2)</sup>	$c_1$	125 <sup>5)</sup>	
					anchor groups <sup>3)</sup>		250	
Minimum edge distance, orthogonal to $c_1$						$c_2$	$1,5 \times c_1$	
Minimum spacing between					single anchors	$a$	600	
					anchors groups <sup>3) 4)</sup>		750	

- <sup>1)</sup> For member thickness  $h < 120$  mm the drill dust has to be cleaned out of the hole and the depth of the drill hole has to be reduced to 80 mm in order to avoid damage on the opposite side of the slab
- <sup>2)</sup> Maximum 2 single anchors in the same formation as anchor groups. For 2 single anchors with spacing smaller than 600 mm ( $s_{min} \geq 100$  mm) the same spacing in between and edge distances ( $a$ ;  $c_1$ ) like for the anchor group are valid
- <sup>3)</sup> For exclusive tension loads the spacing and edge distances for groups can be reduced to the spacing and edge distances of single anchors
- <sup>4)</sup> If there is no (free) edge, or the edge distance is  $\geq a$ , the spacing between anchor groups can be reduced to the spacing between single anchors
- <sup>5)</sup> The edge distance of reinforced slabs with a width  $\leq 700$  mm has to be  $\geq 150$  mm

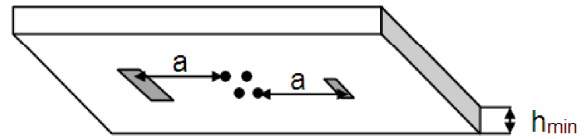
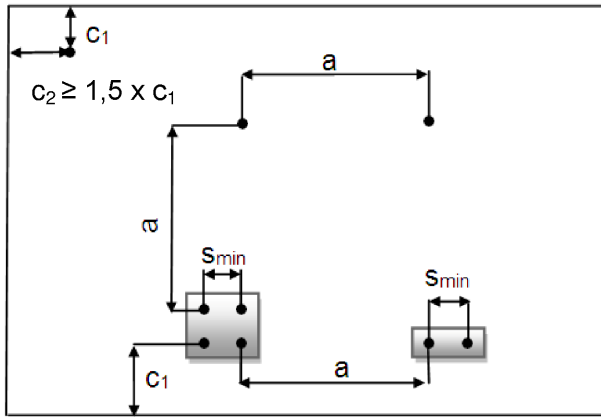

**fischer aircrete anchor FPX-I**

**Intended use**

Minimum member thickness, minimum spacing and edge distance in AAC slabs

**Annex B 3**

Appendix 6 / 10

**Table B4.1: Minimum member thickness, minimum spacing and edge distance in AAC - masonry**

Size	FPX-I			
	M6	M8	M10	M12
Minimum thickness of AAC - masonry	with cleaning <sup>1)</sup>		100	
	without cleaning		120	
Minimum spacing	$S_{min}$		100	
Minimum distance to non-filled joints, single anchor	$C_F$		0 <sup>5)</sup> / 75 <sup>6)</sup> / 125 <sup>7)</sup>	
Minimum edge distance	single anchor <sup>2)</sup>		125	
	anchor groups <sup>3)</sup>		250	
Minimum edge distance, orthogonal to $c_1$	$C_2$		$1,5 \times c_1$	
Minimum spacing between	single anchors <sup>2)</sup>		375	
	anchors groups <sup>3) 4)</sup>		750	

- 1) For member thickness  $h < 120$  mm, the drill hole shall be cleaned and the depth of the drill hole shall be reduced to 80 mm in order to avoid damage on the opposite side of the wall
- 2) Maximum 2 single anchors in the same formation as the anchor groups. For 2 single anchors with spacing smaller than 375 mm ( $S_{min} \geq 100$  mm) the same spacing in between and edge distances ( $a$ ;  $c_1$ ) like for the anchor group are valid
- 3) For exclusive tension loads the spacing and edge distances of anchor groups can be reduced to the spacing and edge distances of single anchors
- 4) If there is no edge, or the edge distance is  $\geq a$ , the spacing between anchor groups can be reduced to the spacing between single anchors
- 5) For joints completely filled with mortar and a joint width  $\leq 12$  mm and a compressive strength according to EN 998-2  $\geq f_{AAC}$  AAC no distances to joints are required
- 6)  $C_F$  for only tension and /or shear loads parallel to the joints which are not filled with mortar and a joint width  $\leq 2$  mm
- 7)  $C_F = C_1$  for shear load or with a part of the load orthogonal to the joint which are not filled with mortar and a joint width  $\geq 0$  mm

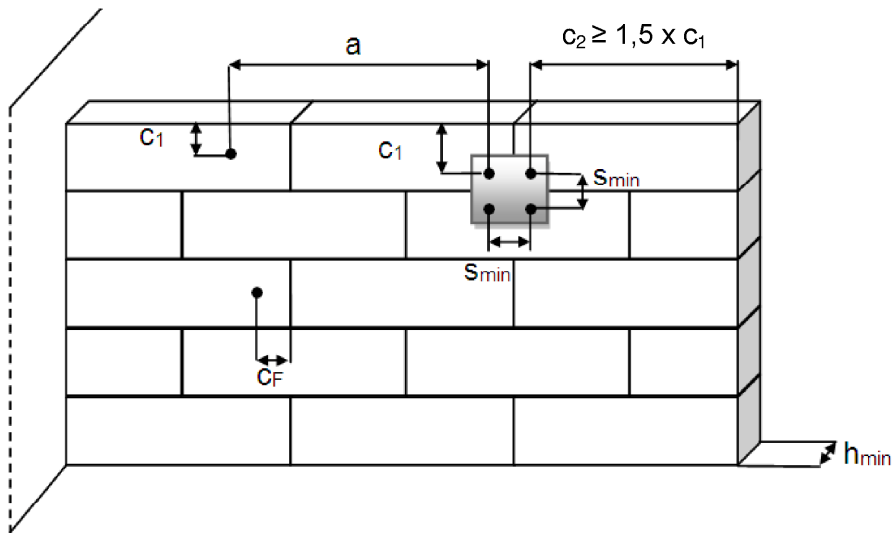

**fischer aircrete anchor FPX-I**

**Intended use**

Minimum member thickness, minimum spacing and edge distance in AAC masonry

**Annex B 4**

Appendix 7 / 10



## Installation instruction

- Anchor installation carried out by appropriately qualified personnel and under the supervision of the person responsible for technical matters of the site
- Use of the anchor only as supplied by the manufacturer without exchanging the components of the anchor
- Checking before placing the anchor to ensure that the strength class of the aircrete in which the anchor is to be placed is in the range given and is not lower than that of the aircrete to which the characteristic loads apply
- Drill hole created perpendicular  $\pm 5^\circ$  to AAC surface, positioning without damaging the reinforcement
- In case of aborted hole: New drilling at a minimum distance away of twice the depth of the aborted hole or smaller distance if the aborted hole is filled with non-shrinkage, high strength mortar (pressure strength  $\geq 30 \text{ N/mm}^2$ ) and if under shear or oblique tension load it is not the direction of the load application

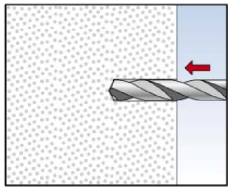

1: Drill the hole. Other methods like punching, to make the hole, are allowed. When the AAC is covered with a hard layer like tiles, the tile has to be drilled with minimum diameter of the head of the internal threaded bolt  $\varnothing D$

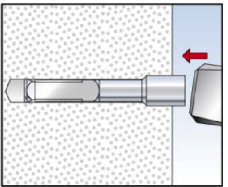

2: Set the fastener until it is flush with the surface of the AAC

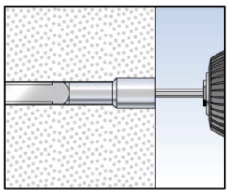

3: Turning the internal thread bolt with the hexagon (approximately 15 turnings are required)

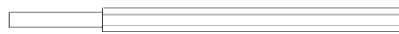

Setting tool for FPX-I M6

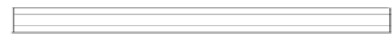

Setting tool for FPX-I M8 – M12

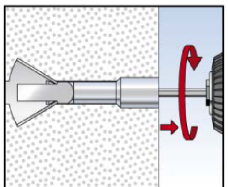

4: By turning the internal thread bolt, the cone is driven into the expansion sleeve. When the optimal expansion is reached, the hexagon is thrown out of the socket. **The turning of the internal thread bolt until the hexagon is thrown out of the socket is compulsory** if tightening is impossible the anchor cannot be loaded

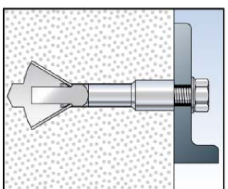

5a: Optional tightening the fastener with a torque  $T_{\max} \leq 3 \text{ Nm}$ . The anchor could be pulled against the fixture depending on the compressive strength of the AAC.

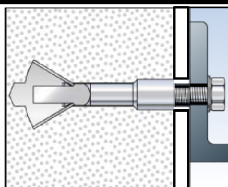

5b: If the anchor cannot support against the fixture (with cover layer) no installation torque may be applied ( $T_{\max} = 0$ )

fischer aircrete anchor FPX-I

Intended use  
Installation instructions

Annex B 5

Appendix 8 / 10

**Table C1.1: Characteristic resistance for all load directions**

Size	FPX-I						
	M6	M8	M10	M12			
<b>Single anchor in AAC - slabs <sup>1)</sup></b>							
Characteristic resistance in cracked AAC - slabs	$F_{Rk}$ [kN]	$f_{AAC} \geq 3,3, \rho_m \geq 0,50$	1,5				
		$f_{AAC} \geq 4,4, \rho_m \geq 0,55$	2,0				
Characteristic resistance in uncracked AAC - slabs	$F_{Rk}$ [kN]	$f_{AAC} \geq 3,3, \rho_m \geq 0,50$	2,0				
		$f_{AAC} \geq 4,4, \rho_m \geq 0,55$	3,0				
Partial safety factor for AAC - slabs		$\gamma_{MAAC}^{2)}$	1,73				
<b>Single anchor in AAC - masonry <sup>1)</sup></b>							
Characteristic resistance in AAC - masonry <sup>3)</sup>	$F_{Rk}$ [kN]	$f_{AAC} \geq 1,6, \rho_m \geq 0,25$	0,9				
		$f_{AAC} \geq 2,0, \rho_m \geq 0,35$	1,2				
Intermediate values by linear interpolation	$F_{Rk}$ [kN]	$f_{AAC} \geq 4,0, \rho_m \geq 0,50$	2,5				
		$f_{AAC} \geq 6,0, \rho_m \geq 0,65$	4,0				
Partial safety factor for AAC - masonry		$\gamma_{MAAC}^{2)}$	2,0				
<b>Single anchor in AAC - slabs and AAC - masonry <sup>1)</sup></b>							
Characteristic bending resistance <sup>1)</sup> with lever arm in combination with screw / threaded rod complying with:	ISO 898-1: 2013	$M_{Rk,s}$ [Nm]	4.8	6	15	30	52
			5.8	8	19	37	65
			6.8	9	23	44	78
			8.8	12	30	60	105
Partial safety factor for steel failure		$\gamma_{Ms}$	1,25				
<b>Anchor groups in cracked and uncracked AAC - slabs and AAC - masonry with n = 2 to n = 4 anchors <sup>3)</sup></b>							
Characteristic resistance for n = 2, n = 4 <sup>4)</sup> $s_{min} \geq 100$ mm, $c_1 \geq 250$ mm <sup>5)</sup>	$F_{Rk,n}$ [kN]	2 x $F_{Rk}$					
Characteristic resistance for n ≥ 3 $s_{min} \geq 140$ mm, $c_{min, anchor group} \geq 700$ mm <sup>5)</sup>		n x $F_{Rk}$					
Characteristic resistance redundancy when the joints are not visible <sup>5)</sup>		$F_{Rk,n,Redundancy}$	0,5 x $F_{Rk,n}$				
Partial safety factor for AAC - slabs		$\gamma_{MAAC}^{2)}$	1,73				
Partial safety factor for AAC - masonry		$\gamma_{MAAC}^{2)}$	2,0				

<sup>1)</sup> Maximum 2 single anchors in the same formation as the anchor groups. For 2 single anchors with spacing smaller than a ( $s_{min} \geq 100$  mm) the characteristic resistance of the anchor group is decisive  
<sup>2)</sup> The installation safety factor  $\gamma_2 = 1,0$  is included  
<sup>3)</sup> The evaluation of  $N_{Rk,pb}$  according to TR 054, Section 4.2.1.5 is necessary. The smaller value of  $N_{Rk,pb}$  and  $F_{Rk}$  is decisive  
<sup>4)</sup> Rectangular arrangement according to drawing Annex B3 and B4  
<sup>5)</sup> Only for multiple use according to EAD 330747-00-0601

The characteristic strength class  $f_{AAC}$  [N/mm<sup>2</sup>] and the characteristic dry density  $\rho_m$  [kg/dm<sup>3</sup>] have to comply with EN 771-4:2011+A1:2015 for AAC - masonry and EN 12602:2016 for AAC - slabs

**Table C2.1:** Characteristic resistance for each anchor under fire exposure for all load directions

Size	FPX-I				
	M6	M8	M10	M12	
Characteristic resistance for cracked <b>slabs</b> of strength class $f_{AAC} \geq 3,3$ , $\rho_m \geq 0,50$	$F_{Rk,fi}$ [kN]	R30	0,4		
		R60	0,4		
		R90	0,3	0,4	
		R120	0,3		
Characteristic resistance for cracked <b>slabs</b> of strength class $f_{AAC} \geq 4,4$ , $\rho_m \geq 0,55$	$F_{Rk,fi}$ [kN]	R30	0,5		
		R60	0,4	0,5	
		R90	0,3	0,5	
		R120	0,3	0,4	
Minimum spacing	$s_{min,fi}$ [mm]	100			
Minimum edge distance	$c_{min,fi}$ [mm]	$c_{min,fi} = 140$ for fire exposure from more than one side $c_{min,fi} \geq 300$ mm			

It must be ensured that local spalling of the autoclaved aerated concrete cover does not occur.

**Table C2.2:** Displacement under tension loads, shear loads and oblique loads in AAC <sup>1)</sup>

Size	FPX-I			
	M6	M8	M10	M12
Displacement tension load in <b>cracked</b> AAC for all AAC strength classes	$\delta_{N0}$	1,0		
	$\delta_{N\infty}$	2,0		
Displacement tension load in <b>uncracked</b> AAC for all AAC strength classes	$\delta_{N0}$	1,0		
	$\delta_{N\infty}$	1,0		
Displacement shear load in <b>cracked and uncracked</b> AAC $f_{AAC} = 1,6 - \rho_m \geq 0,25$ <sup>2)</sup>	$\delta_{V0}$	2,5		
	$\delta_{V\infty}$	3,7		
Displacement shear load in <b>cracked and uncracked</b> AAC $f_{AAC} \geq 6,0 - \rho_m \geq 0,65$ <sup>2)</sup>	$\delta_{V0}$	5,0		
	$\delta_{V\infty}$	7,3		

<sup>1)</sup> Displacement at service load level  $F_{Rk} / (\gamma_{MAAC} \times 1,4)$

<sup>2)</sup> Intermediate values by linear interpolation, taking in account the AAC strength

**fischer aircrete anchor FPX-I**

**Performances**

Characteristic resistance of a fixing point under fire exposure for all load directions  
Displacements under tension, shear loads and oblique loads

**Annex C 2**

Appendix 10 / 10