

SUORITUSTASOILMOITUS

DoP 0302

fischer hollow ceiling anchor FHY (mekaaninen kiinnitin betoniin)

FI

- Tuotetyypin yksilöllinen tunniste: DoP 0302
- Aiottu käyttötarkoitus (aiotut käyttötarkoitukset): Jälkiasennettu kiinnitin käytettäväksi betonissa tarpeettomille ei-rakenteellisille järjestelmille, katso lisäys, erityisesti liitteet B1- B3.
- Valmistaja: fischerwerke GmbH & Co. KG, Klaus-Fischer-Str. 1, 72178 Waldachtal, Saksa
- Valtuutettu edustaja: -
- Suoritusasteen pysyvyyden arvioinnissa ja varmentamisessa käytetty järjestelmä/käytetyt järjestelmät: 2+
- Eurooppalainen arviointiasiakirja: EAD 330747-00-0601
Eurooppalainen tekninen arviointi: ETA-21/0857; 2022-08-30
Teknisestä arvioinnista vastaava laitos: TZÜS - Technical and Test Institute for Construction Prague
Ilmoitettu laitos/ilmoitetut laitokset: 2873 TU Darmstadt
- Ilmoitettu suoritusaste/ilmoitetut suoritusastot:
Käyttöturvallisuus (BWR 4)
Tyypillinen kestävyys kuormitukselle (staattinen ja lähes staattinen kuormitus):
Teräksen murtokuorma: NPD
Ulosvetoarvon murtokuorma: NPD
Betonimassan murtokuorma: NPD
Kestävyys: Liite C1
Pienin reuna- ja keskinäis etäisyys: Liitteet B2, B3
Reunaetäisyys halkeamien estämiseksi kuormituksessa: NPD

Tyypillinen kestävyys leikkauskuormalle (staattinen ja näennäistaattainen kuormitus):
Teräksen murtokuorma (leikkauskuorma): Liite C1
Taivutusvoiman murtokuorma: NPD
Betonireunan murtokuorma: NPD

Ominaisvastus kaikille kuorman suunnille ja vikatiloille yksinkertaistettua suunnittelua varten:
Ominaisarvo: Liite C1

Kestävyys:
Kestävyys: Liitteet A2, B1

Turvallisuus tulipalon sattuessa (BWR 2)
Reaktio paloon: Luokka (A1)
Tulenkestävyys:
Teräksen murtokuorma tulipalossa (vetokuorma): NPD
Ulosvedon murtokuorma tulipalossa (vetokuorma): NPD
Teräksen murtokuorma tulipalossa (leikkauskuorma): NPD
Palonkestävyys kaikissa kuorman suunnissa ja vikatiloissa: Liitteet C2, C3
- Asianmukainen tekninen asiakirja ja/tai tekninen erityisasiakirja: -

$V_{Rk,s}=NPD; k_7=NPD$

Edellä yksilöidyn tuotteen suoritusaste on ilmoitettujen suoritusasteiden joukon mukainen. Tämä suoritusasteilmoitus on asetuksen (EU) N:o 305/2011 mukaisesti annettu edellä ilmoitetun valmistajan yksinomaisella vastuulla.

Valmistajan puolesta allekirjoittanut:



Dr.-Ing. Oliver Geibig, Toimitusjohtaja Liiketoimintayksikkö & Suunnittelu
Tumlingen, 2023-01-17



Jürgen Grün, Toimitusjohtaja Kemia & Laatu

Tämä suoritusasteilmoitus on laadittu useilla kielillä. Jos tulkinnasta syntyy erimielisyyttä, englanninkielinen versio on aina katsottava ensisijaiseksi.

Lisäys sisältää vapaaehtoisesti ilmoitettua ja täydentävää englanninkielistä tietoa, joka ylittää (kielestä riippumatta määritellyt) lakisääteiset vaatimukset.

1. Technical description of the product

The Fischer hollow ceiling anchor FHY is a torque-controlled expansion anchor made of galvanised or stainless steel. It consists of an expansion sleeve and a cone with an internal thread and is anchored by torque-controlled expansion with a hexagon head bolt or threaded rod with nut and washer.

By tightening the screw/nut, the cone is pulled into the expansion sleeve and expanding it. The product description is given in Annex 1.

2. Specification of the intended use in accordance with the applicable EAD

The performances given in Section 3 are only valid if the anchor is used in compliance with the specifications and conditions given in Annex B.

The provisions made in this European Technical Assessment are based on an assumed working life of the anchor of 50 years. The indications given on the working life cannot be interpreted as a guarantee given by the producer, but are to be regarded only as a means for choosing the products in relation to the expected economically reasonable working life of the works.

3. Performance of the product and references to the methods used for its assessment

3.1 Safety in case of fire (BWR 2)

Essential characteristic	Performance
Reaction to fire	Class A1 according to EN 13501-1
Resistance to fire	See Annex C 2 and Annex C 3

3.2 Safety and accessibility in use (BWR 4)

Essential characteristic	Performance
Characteristic resistance for all load directions and modes of failure for simplified design	See Annex C 1
Durability	See Annex B 1

4. Assessment and verification of constancy of performance (AVCP) system applied with reference to its legal base

According to the Decision 97/463/EC of the European Commission¹, the system 2+ of assessment verification of constancy of performance (see Annex V to the Regulation (EU) No 305/2011) apply.

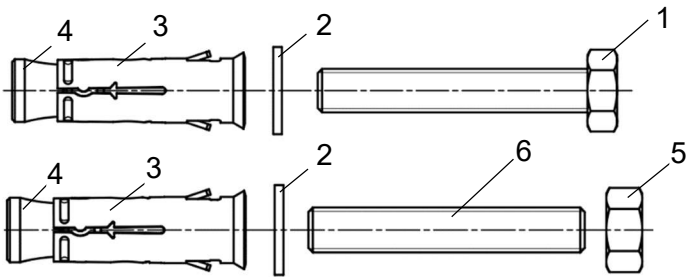

- 1 Hexagon screw
- 2 Washer
- 3 Expansion sleeve
- 4 Cone nut
- 5 Hexagon nut
- 6 Threaded rod

Installed Condition:

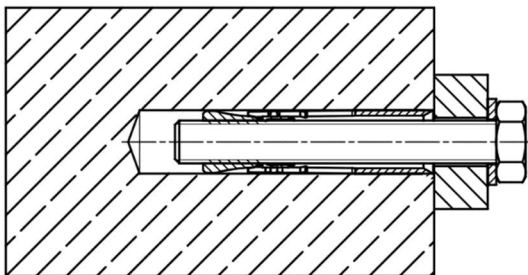
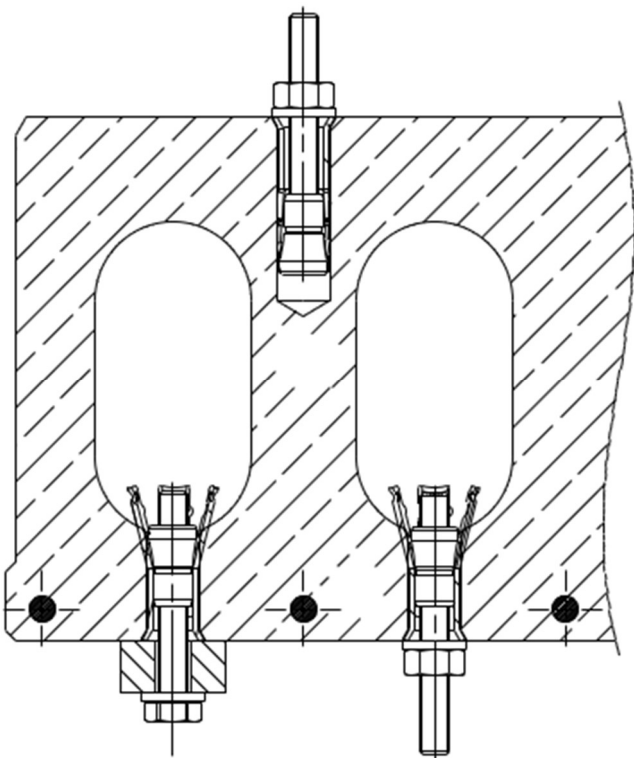

(Fig. not to scale)

fischer hollow ceiling anchor FH Y

Product description
Installed conditions

Annex A 1

Appendix 2 / 10

Product marking and dimensions:

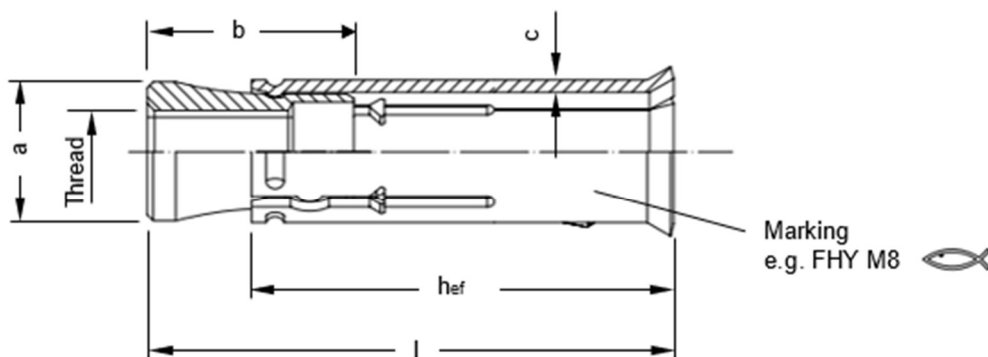

FHY: Carbon steel, galvanised

FHY R: Stainless steel

Table A2.1: Dimensions [mm]

Typ	h_{ef}	Thread	$\varnothing a$	b	c	l
FHY M6	30	M6	9,6	16,0	1,0	37
FHY M8	35	M8	11,5	17,0	1,0	43
FHY M10	40	M10	15,0	23,5	1,5	52
FHY M12	40	M12	17,0	26,5	1,5	55

Table A2.2: Materials FHY

Part	Designation	Material	
		FHY	FHY R
	Type of steel	Steel Zinc plated $\geq 5 \mu\text{m}$, ISO 4042:2018	Stainless steel R Acc. to EN 10088:2014 Corrosion resistance class CRC III acc. to EN 1993-1-4:2015
1	Hexagon screw ¹⁾	Steel, DIN EN ISO 898-1:2013 property class 8.8 (M6); property class 4.6, 5.8 or 8.8 (M8, M10 and M12)	DIN EN ISO 3506-1:2020; property class ≥ 70
2	Washer ¹⁾	Cold strip, EN 10139:2016+A1:2020	Stainless steel EN 10088:2014
3	Expansion sleeve	Cold strip, EN 10139:2016+A1:2020	
4	Cone nut	Steel DIN EN 10277: 2018	
5	Hexagon nut ¹⁾	Steel DIN EN ISO 898-2:2012; property class 8 (M6) and 4 or 5 or 8 (M8 -M12)	Stainless steel DIN EN ISO 3506-2:2020; property class ≥ 70
6	Threaded rod ¹⁾	Steel DIN EN ISO 898-1:2013, property class 8.8 (M6) and 4.8, 5.8 or 8.8 (M8) 4.6, 5.8 or 8.8 (M10 -M12)	Stainless steel DIN EN ISO 3506-1:2020; property class ≥ 70

¹⁾ Commercial threaded rods, washers, hexagon nuts and hexagon screws may also be used if the requirements in Table A2.2 are fulfilled.

(Fig. not to scale)

fischer hollow ceiling anchor FHY



Product description
Product label and dimensions

Annex A 2

Appendix 3 / 10

Specifications of intended use

Fastenings subject to:

Size	FHY, FHY R			
	M6	M8	M10	M12
Hammer drilling with standard drill bit 			✓	
Hammer drilling with hollow drill bit with automatic cleaning 			✓	
Static and quasi-static loads				
Cracked and uncracked concrete			✓	
Fire exposure				

Base materials:

- Compacted reinforced and unreinforced normal weight concrete without fibres (cracked and uncracked) according to EN 206-1:2013+A1:2016
- Strength classes \geq C20/25 according to EN 206-1:2013+A1:2016
- Prestressed hollow core slabs, where the cavity width does not exceed 4,2 times the web width ($b_H \leq 4,2 \times b_{St}$) with strength classes \geq C45/55

Use conditions (Environmental conditions):

- Structures subject to dry internal conditions (FHY, FHY R)
- For all other conditions according to EN 1993-1-4:2006 + A1:2015 corresponding to corrosion resistance class
 - CRC III: FHY R

Design:

- Fastenings are to be designed under the responsibility of an engineer experienced in fastenings and concrete work
- Verifiable calculation notes and drawings are to be prepared taking account of the loads to be anchored. The position of the fastener is indicated on the design drawings (e.g. position of the fastener relative to reinforcement or to supports, etc.)
- Design under static or quasi-static actions shall be performed in accordance with EN 1992-4:2018, design method B

fischer hollow ceiling anchor FHY

Intended use
Specifications

Annex B 1
Appendix 4 / 10

Table B2.1: Installation parameters

Size		FHY, FHY R					
		M6	M8	M10	M12		
Nominal drill hole diameter	$d_0 =$	10	12	16	18		
Effective embedment depth	$h_{ef} \geq$	30	35	40	40		
Depth of drill hole to deepest point	$h_1 \geq$	50	60	65	70		
Diameter of clearance hole in the fixture	$d_f \leq$	7	9	12	14		
Length of screw ¹⁾	$l_s \geq$	$37 + t_{washer} + t_{fix}$	$43 + t_{washer} + t_{fix}$	$52 + t_{washer} + t_{fix}$	$55 + t_{washer} + t_{fix}$		
Length of the threaded bolt	$l_b \geq$	$42 + t_{washer} + t_{fix}$	$50 + t_{washer} + t_{fix}$	$60 + t_{washer} + t_{fix}$	$65 + t_{washer} + t_{fix}$		
Required setting torque	FHY FHY R	$T_{inst} =$	[Nm]	8 15	10 20	20 40	30 50

¹⁾ For screws with shaft according to EN ISO 4017:2014 the shaft length must be $\leq t_{fix}$

Pre-stressed hollow core slab \geq C45/55 web thickness \geq 25mm						
Minimum spacing	$s_{min} \geq$	[mm]	70	70	80	80
Minimum edge distance	$c_{min} \geq$	[mm]	100	100	100	150
Solid concrete \geq C20/25						
Minimum spacing	$s_{min} \geq$	[mm]	70	70	80	80
Minimum edge distance	$c_{min} \geq$	[mm]	100			
Minimum thickness of concrete member	$h_{min} \geq$	[mm]	100			

Anchoring in precast pre-stressed concrete hollow concrete slabs and in area of solid material

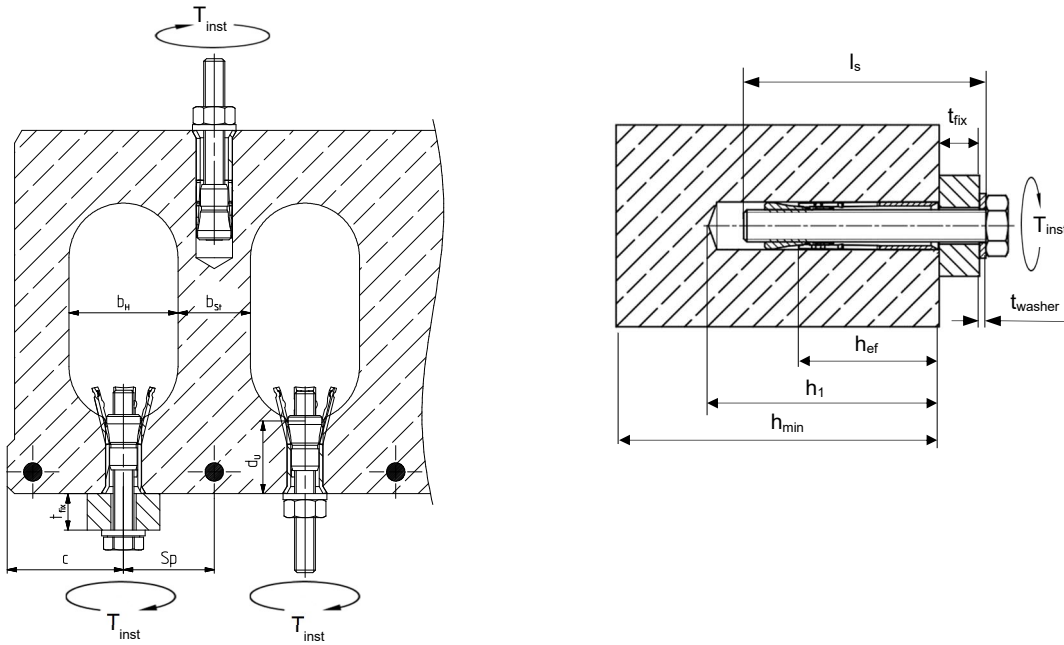

- s_p = Distance to the tensioning strands
- t_{fix} = Thickness of the fixture
- d_u = Thickness of the slab web
- c = Edge distance

(Fig. not to scale)

fischer hollow ceiling anchor FHY

Intended use
Installation parameters

Annex B 2
Appendix 5 / 10

Anchor configuration Condition: $b_H \leq 4,2 \times b_{St}$

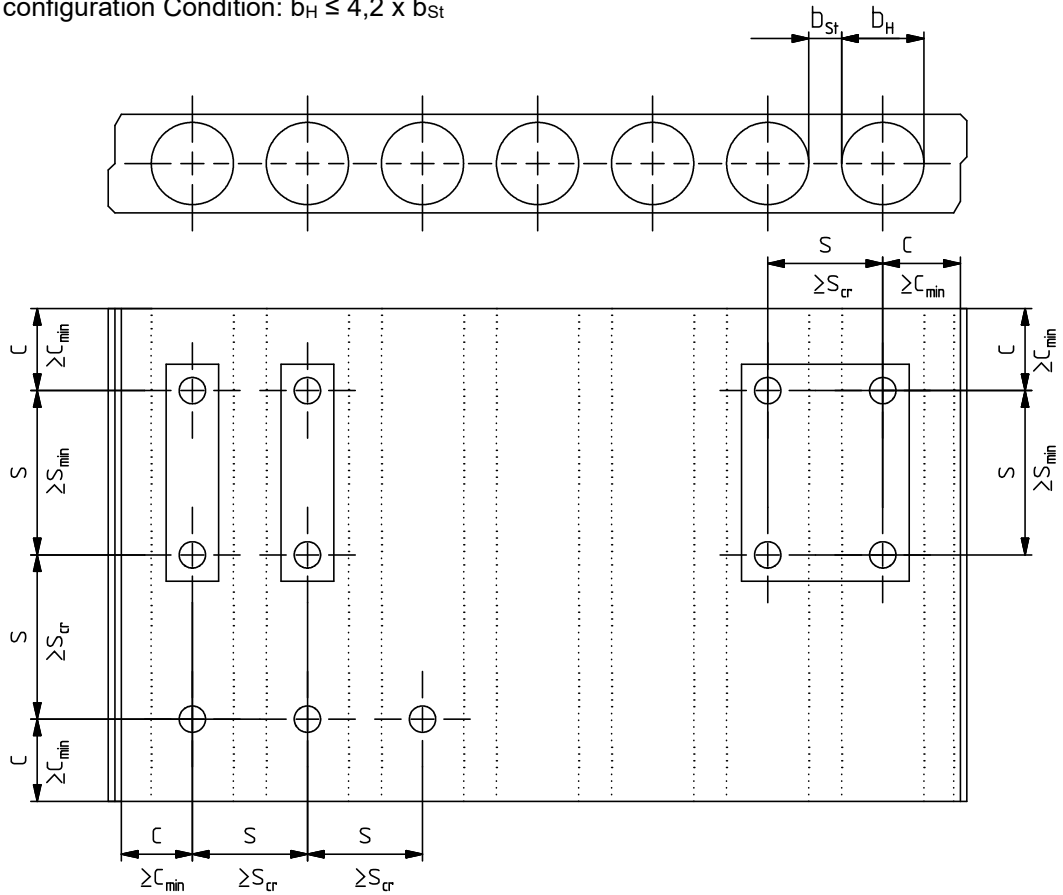

s_{min} and C_{min} see Annex B 2. s_{cr} see Annex C 1

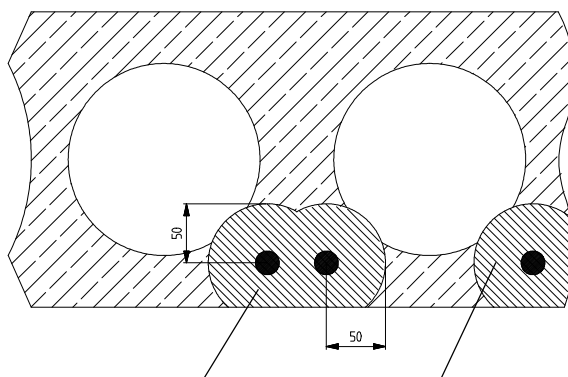

Area where no anchoring is allowed

The anchoring must have a distance from the anchor axis to the tensioning strands of at least 50 mm

(Fig. not to scale)



fischer hollow ceiling anchor FHY

Intended use
Installation parameters

Annex B 3
Appendix 6 / 10

Installation instructions:

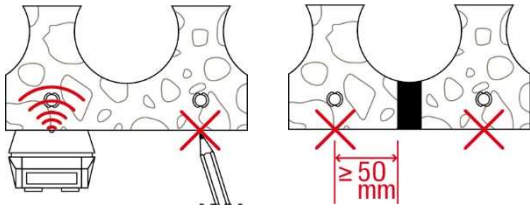
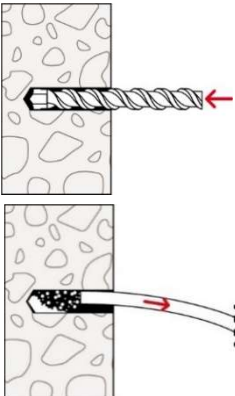
- Fastener installation carried out by appropriately qualified personnel and under the supervision of the person responsible for technical matters on the site
- Hammer or hollow drilling
- Drill hole created perpendicular +/- 5° to concrete surface, positioning without damaging the reinforcement
- In case of aborted hole in solid material: new drilling at a minimum distance twice the depth of the aborted drill hole or smaller distance if the aborted drill hole is filled with high strength mortar and if under shear or oblique tension load it is not in the direction of load application
- In Precast pre-stressed hollow core slabs the anchor FHY may be installed from all directions, if the web thicknesses is ≥ 25mm and the spacing to the tensioning strands of ≥ 50mm is observed (also in the area of solid material)

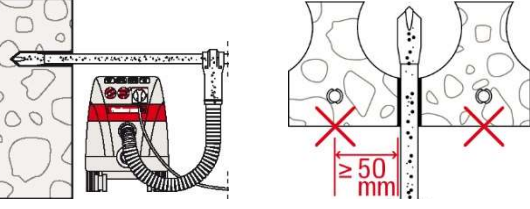
<p>1a) Hammer drill (e.g. fischer Quattric II)</p>		 <p>Prestressed hollow core slabs: Determine and mark the position of the tensioning strands, e.g. with a suitable scanner.</p>	 <p>Solid material/solid areas of hollow core slabs</p>
<p>1b) Hollow drill (e.g. fischer FHD)</p>		 <p>Drill the hole with automatic cleaning (e.g. fischer FVC)</p>	<p>-</p>

Installation of the fastener (exemplary in a pre-stressed hollow core slabs)

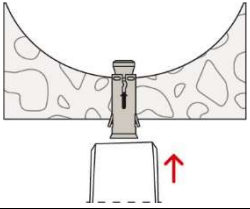
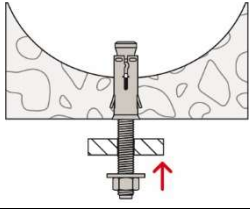
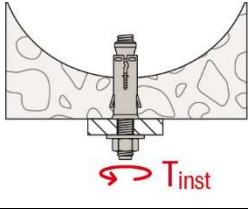
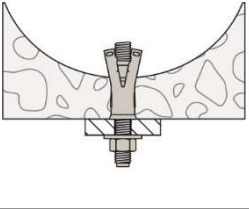
			
<p>Set the fastener</p>	<p>Fixation of fixture</p>	<p>Apply T_{inst}</p>	<p>Installed fastener</p>

fischer hollow ceiling anchor FHY

Intended use
Installation instructions

Annex B 4
Appendix 7 / 10

Table C1.1: Characteristic resistance for all load directions								
Size			FHY, FHY R					
			M6	M8	M10	M12		
Concrete solid material								
Characteristic resistance in C20/25	F^{0}_{Rk}	[kN]	3,0	6,5	8,5	8,5		
Partial factor	γ_{Mc}	[-]	1,5	1,5	1,5	1,5		
Characteristic spacing	S_{cr}	[mm]	200	200	200	200		
Characteristic edge distance	C_{cr}		100	105	120	120		
Pre-stressed hollow core slab \geq C45/55								
Characteristic resistance	$d_u \geq 25 \text{ mm} < 30 \text{ mm}$	F^{0}_{Rk}	[kN]	5,0	7,0	8,0	9,0	
	$d_u \geq 30 \text{ mm} < 40 \text{ mm}$			5,0	7,0	10,0	9,0	
	$d_u \geq 40 \text{ mm}$			5,0	7,0	10,0	10,0	
Partial factor	γ_{Mc}	[-]	1,5	1,5	1,5	1,5		
Characteristic spacing	$d_u \geq 25 \text{ mm} < 30 \text{ mm}$	S_{cr}	[mm]	200	200	200	200	
	$d_u \geq 30 \text{ mm} < 40 \text{ mm}$			200	200	200	200	
	$d_u \geq 40 \text{ mm}$			200	200	200	200	
Characteristic edge distance	$d_u \geq 25 \text{ mm} < 30 \text{ mm}$	C_{cr}	[mm]	100	100	100	150	
	$d_u \geq 30 \text{ mm} < 40 \text{ mm}$			100	100	100	150	
	$d_u \geq 40 \text{ mm}$			100	105	120	150	
Characteristic bending moment								
FHY	Property class of the screw/ threaded rod	4.6 / 4.8	$M^{0}_{Rk,s}$	[Nm]	-2)	15,0	29,9	52,4
		5.8			-2)	18,7	37,4	65,5
		8.8			12,2	30,0	62,3	109,2
FHY R		\geq A4-70			10,7	26,4	52,3	91,7
FHY	Partial factor above property class	4.6	$\gamma_{Ms}^{1)}$	[-]	-2)	1,67	1,67	1,67
		4.8 / 5.8			-2)	1,25	1,25	1,25
		8.8			1,25	1,25	1,25	1,25
FHY R		\geq A4-70			1,56	1,56	1,56	1,56
¹⁾ In absence of other national regulations ²⁾ No Performance assessed								
fischer hollow ceiling anchor FHY						Annex C 1 Appendix 8 / 10		
Performances Characteristic resistance for all load directions								

Table C2.1: Characteristic resistance under **fire exposure** for concrete solid material for all load directions

Size		FHY				
		M6	M8	M10	M12	
Characteristic resistance for all load directions Concrete solid material	F _{RK,fi} [kN]	R30	0,75	1,25	1,74	1,74
		R60	0,58	1,25	1,74	1,74
		R90	0,38	0,8	1,3	1,74
		R120	0,28	0,57	0,96	1,39
Characteristic resistance for shear load with lever arm Concrete solid material	M ⁰ _{RK,fi} [Nm]	R30	0,6	1,8	3,4	6,0
		R60	0,4	1,3	2,5	4,5
		R90	0,3	0,8	1,7	2,9
		R120	0,2	0,6	1,2	2,2

Size		FHY R				
		M6	M8	M10	M12	
Characteristic resistance for all load directions Concrete solid material	F _{RK,fi} [kN]	R30	0,75	1,25	1,74	1,74
		R60	0,75	1,25	1,74	1,74
		R90	0,75	0,96	1,06	1,54
		R120	0,6	0,48	0,69	1,00
Characteristic resistance for shear load with lever arm Concrete solid material	M ⁰ _{RK,fi} [Nm]	R30	1,9	2,9	3,3	5,7
		R60	1,3	2,0	2,3	4,1
		R90	0,8	1,0	1,4	2,4
		R120	0,5	0,5	0,9	1,6

Concrete pryout failure according to EN 1992-4:2018

fischer hollow ceiling anchor FHY

Performances
Characteristic values of resistance under fire exposure for concrete solid material

Annex C 2
Appendix 9 / 10

Table C3.1: Characteristic resistance under **fire exposure** for pre-stressed hollow core slabs for all load directions

Size			FHY			
			M6	M8	M10	M12
Characteristic resistance for all load directions Pre-stressed hollow core slabs	$d_u \geq 25 \text{ mm} < 30 \text{ mm}$	R30	0,78	1,15	1,15	1,15
		R60	0,58	1,15	1,15	1,15
		R90	0,38	0,80	1,15	1,15
		R120	0,28	0,57	0,92	0,92
	$d_u \geq 30 \text{ mm} < 40 \text{ mm}$	R30	0,78	1,52	1,52	1,52
		R60	0,58	1,26	1,52	1,52
		R90	0,38	0,80	1,30	1,52
		R120	0,28	0,57	0,96	1,21
	$d_u \geq 40 \text{ mm}$	R30	0,78	1,71	2,33	2,33
		R60	0,58	1,26	1,98	2,33
		R90	0,38	0,80	1,30	1,89
		R120	0,28	0,57	0,96	1,39
Characteristic resistance for shear load with lever arm Pre-stressed hollow core slabs $d_u \geq 25 \text{ mm}$	R30	0,6	1,8	3,4	6,0	
	R60	0,4	1,3	2,5	4,5	
	R90	0,3	0,8	1,7	2,9	
	R120	0,2	0,6	1,2	2,2	
FHY-R						
Size			M6	M8	M10	M12
Characteristic resistance for all load directions Pre-stressed hollow core slabs	$d_u \geq 25 \text{ mm} < 30 \text{ mm}$	R30	1,15	1,15	1,15	1,15
		R60	1,15	1,15	1,15	1,15
		R90	1,04	0,96	1,06	1,15
		R120	0,68	0,48	0,69	0,92
	$d_u \geq 30 \text{ mm} < 40 \text{ mm}$	R30	1,52	1,52	1,52	1,52
		R60	1,52	1,52	1,52	1,52
		R90	1,04	0,96	1,06	1,52
		R120	0,68	0,48	0,69	1,00
	$d_u \geq 40 \text{ mm}$	R30	1,52	1,91	2,33	2,33
		R60	1,52	1,91	1,80	2,33
		R90	1,04	0,96	1,06	1,54
		R120	0,68	0,48	0,69	1,00
Characteristic resistance for shear load with lever arm Pre-stressed hollow core slabs $d_u \geq 25 \text{ mm}$	R30	1,9	2,9	3,3	5,7	
	R60	1,3	2,0	2,3	4,1	
	R90	0,8	1,0	1,4	2,4	
	R120	0,5	0,5	0,9	1,6	

Concrete pryout failure according to EN 1992-4:2018

fischer hollow ceiling anchor FHY

Performances
Characteristic values of resistance under fire exposure for pre-stressed hollow core slabs

Annex C 3
Appendix 10 / 10