

SUORITUSTASOILMOITUS

DoP 0353

fischer voima-ankkuri Highbond-Anchor FHB / FHB dyn / FDA (laajeneva ankkuri kiinnityksissä betoniin)

FI

- Tuotetyypin yksilöllinen tunnistus: DoP 0353
- Aiottu käyttötarkoitus (aiotut käyttötarkoitukset): Jälkikäteen tehtäviin kiinnityksiin halkeilevassa tai halkeilemattomassa betonissa, katso lisäys, erityisesti liitteet B1 - B19.
- Valmistaja: fischerwerke GmbH & Co. KG, Klaus-Fischer-Str. 1, 72178 Waldachtal, Saksa
- Valtuutettu edustaja: -
- Suoritusasteen pysyvyyden arvioinnissa ja varmentamisessa käytetty järjestelmä/käytetyt järjestelmät: 1
- Eurooppalainen arviointiasiakirja: EAD 330499-02-0601, Edition 12/2023
Eurooppalainen tekninen arviointi: ETA-06/0171; 2024-02-15
Teknisestä arvioinnista vastaava laitos: DIBt- Deutsches Institut für Bautechnik
Ilmoitettu laitos/ilmoitetut laitokset: 2873 TU Darmstadt
- Ilmoitettu suoritusaste/ilmoitetut suoritusastot:
Mekaaninen kestävyys ja vakaus (BWR 1)
Tyypillinen kestävyys kuormitukselle (staattinen ja lähes staattinen kuormitus):
 - 1) Teräksen murtokuorma: katso lisäys, erityisesti liitte C1
 - 2) Ulosvetoarvon murtokuorma: katso lisäys, erityisesti liitteet C2,C3
 - 3) Betonimassan murtokuorma: katso lisäys, erityisesti liitte C2
 - 4) Reunaetäisyys halkeamien estämiseksi kuormituksessa: katso lisäys, erityisesti liitte C2
 - 5) Kestävyys: katso lisäys, erityisesti liitteet C2, C3
 - 6) Asennusmomentti: katso lisäys, erityisesti liitteet B5-B8
 - 7) Pienin reuna- ja keskinäis etäisyys, elementin paksuus: katso lisäys, erityisesti liitteet B5-B8
Tyypillinen kestävyys leikkauskuormalle (staattinen ja näennäisstaattinen kuormitus):
 - 8) Teräksen murtokuorma: katso lisäys, erityisesti liitte C1
 - 9) Taivutusvoiman murtokuorma: katso lisäys, erityisesti liitte C2
 - 10) Betonireunan murtokuorma: katso lisäys, erityisesti liitte C2
Siirtymät lyhyt-kestoisessa ja pitkä-kestoisessa kuormituksessa:
 - 11) Siirtymät lyhyt-kestoisessa ja pitkä-kestoisessa kuormituksessa: katso lisäys, erityisesti liitte C4
 - 12) Teräskuituvahvisteisen betonin kestävyys: katso lisäys, erityisesti liitteet B3, B4, C1-C4
Ominainen kestävyys ja siirtymät seismisille suoritusluokille C1 ja C2:
 - 13) Kestävyys kuormitukselle, luokka C1: NPd
 - 14) Kestävyys kuormitukselle, luokka C2: NPd
 - 15) Leikkauskuorman kestävyys, luokka C1: NPd
 - 16) Leikkauskuorman kestävyys, luokka C2: NPd
Turvallisuus tulipalon sattuessa (BWR 2)
 - 17) Reaktio paloon: Luokka (A1)
Palonkestävyys:
 - 18) Palonkestävyys ennen teräksen murtumista (vetokuorma): NPd
 - 19) Liiman kestävyys palo-olosuhteissa: NPd
 - 20) Palonkestävyys ennen teräksen murtumista (leikkauskuorma): NPd
Hygienia, terveys ja ympäristö (BWR 3)
 - 21) Vaarallisten aineiden pitoisuus, päästöt ja / tai vapautuminen: NPd
- Asianmukainen tekninen asiakirja ja/tai tekninen erityisasiakirja: -

Edellä yksilöidyn tuotteen suoritusaste on ilmoitettujen suoritusasteiden joukon mukainen. Tämä suoritusasteilmoitus on asetuksen (EU) N:o 305/2011 mukaisesti annettu edellä ilmoitetun valmistajan yksinomaisella vastuulla.

Valmistajan puolesta allekirjoittanut:



Dr.-Ing. Oliver Geibig, Toimitusjohtaja Liiketoimintayksikkö & Suunnittelu
Tumlingen, 2024-02-23

Jürgen Grün, Toimitusjohtaja Kemia & Laatu

Tämä suoritusasteilmoitus on laadittu useilla kielillä. Jos tulkinnasta syntyy erimielisyyttä, englanninkielinen versio on aina katsottava ensisijaiseksi.

Lisäys sisältää vapaaehtoisesti ilmoitettua ja täydentävää englanninkielistä tietoa, joka ylittää (kielestä riippumatta määritellyt) lakisääteiset vaatimukset.

Translation guidance Essential Characteristics and Performance Parameters for Annexes

Käännösopas oleellisten piirteiden ja suorituskyvyn parametrien liitteille

Mekaaninen kestävyys ja vakaus (BWR 1)

Characteristic resistance to tension load (static and quasi-static loading):

Tyypillinen kestävyys kuormitukselle (staattinen ja lähes staattinen kuormitus):

1	Resistance to steel failure: Teräksen murtokuorma:	$N_{Rk,s}$ [kN]
2	Resistance to combined pull-out and concrete cone failure: Ulosvetoarvon ja betonikuorman varmuuskerroin:	τ_{Rk} and/or $\tau_{Rk,100}$ [N/mm ²], $\psi_c, \psi_{sus}, \psi_{sus,100}$ [-] (BF)
	Resistance to pull-out failure: Ulosvetoarvon murtokuorma:	$N_{Rk,p}$ and/or $N_{Rk,p,100}$ [kN], ψ_c [-] (BEF)
3	Resistance to concrete cone failure: Betonimassan murtokuorma:	$c_{cr,N}$ [mm], $k_{cr,N}, k_{ucr,N}$ [-]
4	Edge distance to prevent splitting under load: Reunaetäisyys halkeamien estämiseksi kuormituksessa:	$c_{cr,sp}$ [mm]
5	Robustness: Kestävyys:	γ_{inst} [-]
6	Maximum installation torque: Maximi asennusmomentti:	$\max T_{inst}$ [Nm] (BF)
	Installation torque: Asennusmomentti:	T_{inst} [Nm] (BEF)
7	Minimum edge distance, spacing and member thickness: Pienin reuna- ja keskinäis etäisyys, elementin paksuus:	$c_{min}, s_{min}, h_{min}$ [mm]

Characteristic resistance to shear load (static and quasi-static loading):

Tyypillinen kestävyys leikkauskuormalle (staattinen ja näennisstaattinen kuormitus):

8	Resistance to steel failure: Teräksen murtokuorma:	$V_{Rk,s}$ [kN], $M_{Rk,s}^0$ [Nm], k_7 [-]
9	Resistance to pry-out failure: Taivutusvoiman murtokuorma:	k_8 [-]
10	Resistance to concrete edge failure: Betonireunan murtokuorma:	d_{nom}, l_f [mm]

Displacements under short-term and long-term loading:

Siirtymät lyhyt-kestoisessa ja pitkä-kestoisessa kuormituksessa:

11	Displacements under short-term and long-term loading: Siirtymät lyhyt-kestoisessa ja pitkä-kestoisessa kuormituksessa:	δ_0, δ_∞ [mm or mm/(N/mm ²)]
12	Resistance in steel fibre reinforced concrete: Teräskuituvahvistetun betonin kestävyys:	Description

Characteristic resistance and displacements for seismic performance categories C1 and C2:

Ominainen kestävyys ja siirtymät seismisille suoritusluokille C1 ja C2:

13	Resistance to tension for seismic performance category C1 Kestävyys kuormitukselle, luokka C1:	$N_{Rk,s,C1}$ [kN] (all) $T_{Rk,C1}$ [N/mm ²] (BF) $N_{Rk,p,C1}$ [kN] (BEF)
14	Resistance to tension for seismic performance category C2 Kestävyys kuormitukselle, luokka C2:	$N_{Rk,s,C2}$ [kN] (all) $T_{Rk,C2}$ [N/mm ²] (BF) $N_{Rk,p,C2}$ [kN] (BEF) $\delta_{N,C2}$ [mm] (all)
15	Resistance to shear for seismic performance category C1 Leikkauskuorman kestävyys, luokka C1:	$V_{Rk,s,C1}$ [kN] (all)
16	Resistance to shear for seismic performance category C2 Leikkauskuorman kestävyys, luokka C2:	$V_{Rk,s,C2}$ [kN] (all) $\delta_{V,C2}$ [mm] (all)

Safety in case of fire (BWR 2)

Turvallisuus tulipalon sattuessa (BWR 2)

17	Reaction to fire Reaktio paloon:	Class Luokka (A1)
----	--	----------------------

Resistance to fire

Palonkestävyys:

18	Fire resistance to steel failure (tension load): Palonkestävyys ennen teräksen murtumista (vetokuorma):	$N_{Rk,s,fi}$ [kN]
19	Bond resistance under fire conditions: Liiman kestävyys palo-olosuhteissa:	$k_{fi,p}(\theta)$ [-], $T_{Rk,fi}(\theta)$ [N/mm ²] (BF)
20	Fire resistance to steel failure under shear loading: Palonkestävyys ennen teräksen murtumista (leikkauskuorma):	$V_{Rk,s,fi}$ [kN], $M_{Rk,s,fi}^0$ [Nm]

Hygiene, health and the environment (BWR 3)

Hygienia, terveys ja ympäristö (BWR 3)

21	Content, emission and/or release of dangerous substances: Vaarallisten aineiden pitoisuus, päästöt ja / tai vapautuminen:	Description/Level
----	---	-------------------

Specific Part

1 Technical description of the product

The Fischer Highbond-Anchor FHB / FHB dyn / FDA is a bonded expansion fastener consisting of an injection cartridge FIS HB and a steel element. The steel element is made of zinc plated or stainless steel.

The load transfer is realized by mechanical interlock of several cones in the bonding mortar and a combination of bonding and friction forces in the concrete.

The product description is given in Annex A.

2 Specification of the intended use in accordance with the applicable European Assessment Document

The performances given in Section 3 are only valid if the anchor is used in compliance with the specifications and conditions given in Annex B.

The verifications and assessment methods on which this European Technical Assessment is based lead to the assumption of a working life of the anchor of at least 50 years. The indications given on the working life cannot be interpreted as a guarantee given by the producer, but are to be regarded only as a means for choosing the right products in relation to the expected economically reasonable working life of the works.

3 Performance of the product and references to the methods used for its assessment

3.1 Mechanical resistance and stability (BWR 1)

Essential characteristic	Performance
Characteristic resistance to tension load (static and quasi-static loading)	See Annex C1 to C3, B5 to B8
Characteristic resistance to shear load (static and quasi-static loading)	See Annex C1 and C2
Displacements under short-term and long-term loading	See Annex C4
Characteristic resistance and displacements for seismic performance categories C1 and C2	No performance assessed

3.2 Safety in case of fire (BWR 2)

Essential characteristic	Performance
Reaction to fire	Class A1

3.3 Hygiene, health and the environment (BWR 3)

Essential characteristic	Performance
Content, emission and/or release of dangerous substances	No performance assessed

4 Assessment and verification of constancy of performance (AVCP) system applied, with reference to its legal base

In accordance with the European Assessment Document EAD 330499-02-0601 the applicable European legal act is: [96/582/EC].

The system to be applied is: 1

Installation conditions part 1, FHB / FHB N

fischer Highbond-Anchor FHB / FHB N with fischer injection system FIS HB

Pre-positioned installation

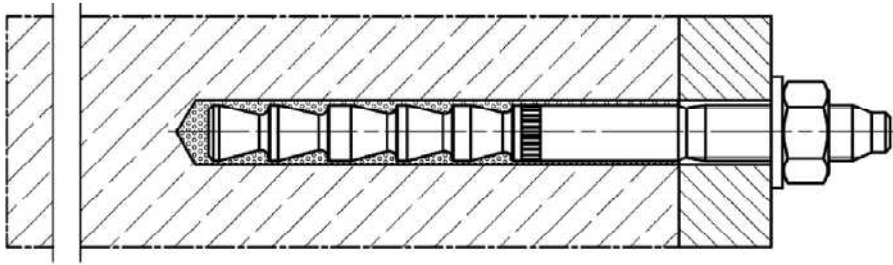

Pre-positioned or push through installation with subsequently injected fischer filling disc (annular gap filled with mortar)

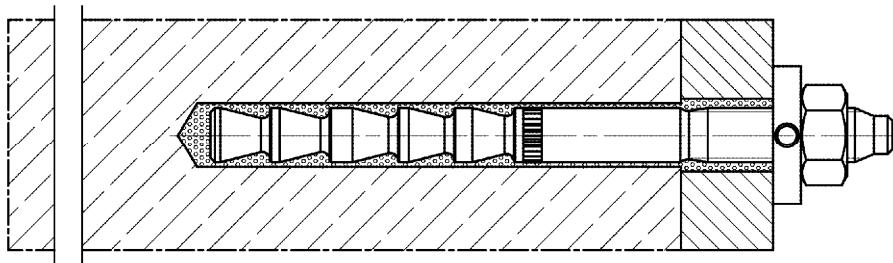

Figures not to scale

fischer Highbond-Anchor FHB / FHB dyn / FDA

Product description

Installation conditions part 1, fischer Highbond-Anchor FHB / FHB N

Annex A1

Appendix 3 / 38

Installation conditions part 2, FHB dyn

fischer Highbond-Anchor dynamic FHB dyn with fischer injection system FIS HB

Pre-positioned installation without shear force sleeve, FHB dyn (annular gap filled with mortar)

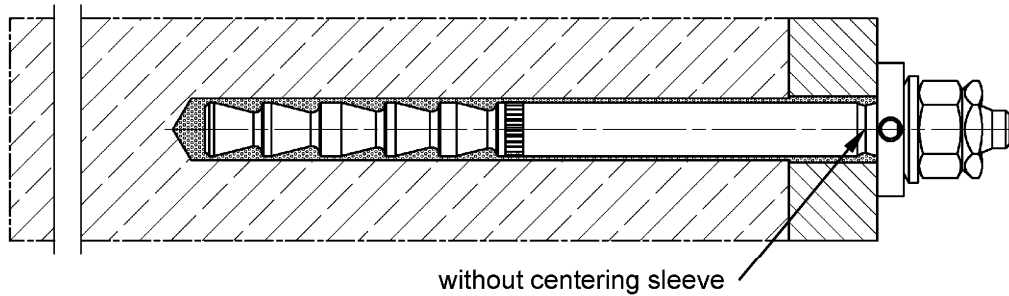

Push through installation without shear force sleeve, FHB dyn (annular gap filled with mortar)

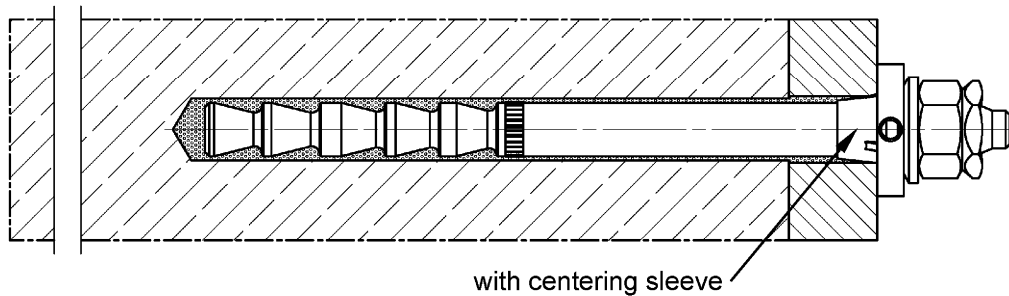

Push through installation with shear force sleeve, FHB dyn V (annular gap filled with mortar)

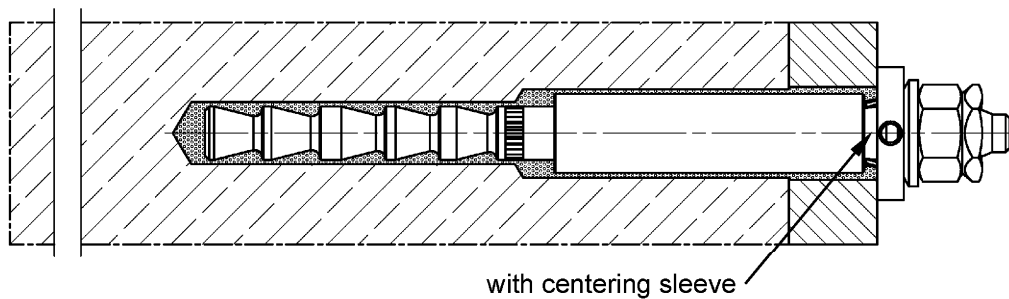

Figures not to scale

fischer Highbond-Anchor FHB / FHB dyn / FDA

Product description

Installation conditions part 2, fischer Highbond-Anchor FHB dyn

Annex A2

Appendix 4 / 38

Installation conditions part 3, FDA

fischer Dynamic-Anchor FDA with fischer injection system FIS HB

Push through installation (annular gap filled with mortar)

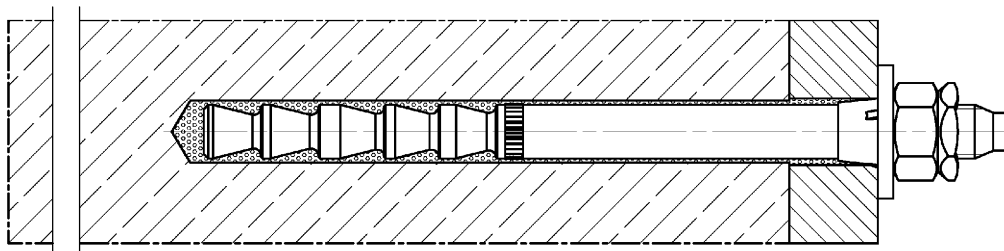

Figures not to scale

fischer Highbond-Anchor FHB / FHB dyn / FDA

Product description

Installation conditions part 3, fischer Dynamic-Anchor FDA

Annex A3

Appendix 5 / 38

Overview system components part 1

Injection cartridge (shuttle cartridge) with sealing cap

Size: 360 ml, 825 ml

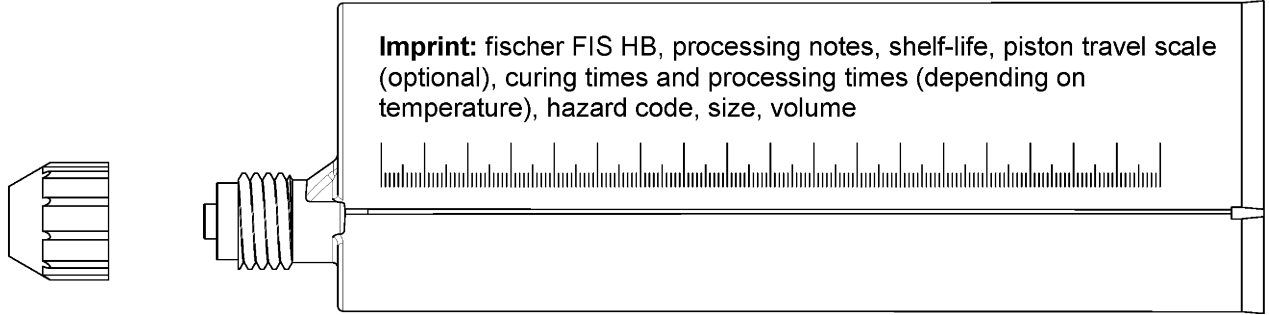

Injection cartridge (coaxial cartridge) with sealing cap

Size: 150 ml, 300 ml, 380 ml, 400 ml, 410 ml

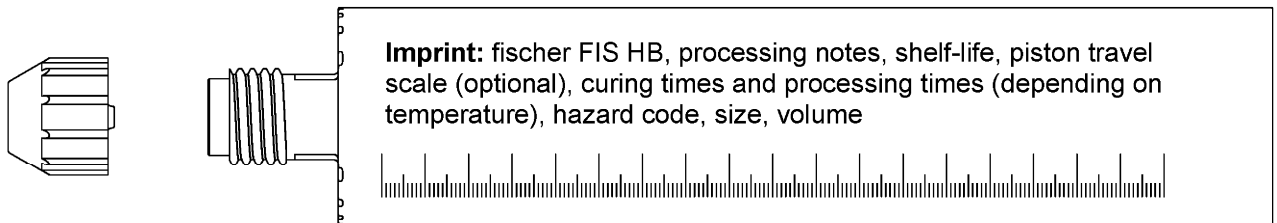

Static mixer FIS MR Plus for injection cartridges up to 410 ml

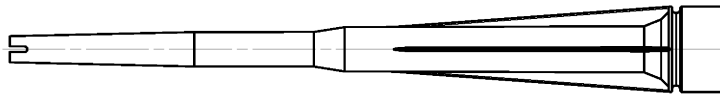

Static mixer FIS JMR for injection cartridge 825 ml

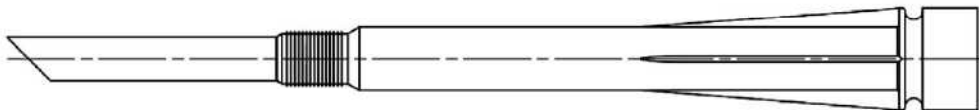

Injection adapter and extension tube Ø 9 for static mixer FIS MR Plus; Injection adapter and extension tube Ø 9 or Ø 15 for static mixer FIS JMR

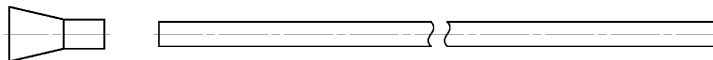

Injection adapter

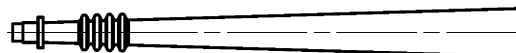

Figures not to scale

fischer Highbond-Anchor FHB / FHB dyn / FDA

Product description

Overview system components part 1
cartridges / static mixer / accessories

Annex A4

Appendix 6 / 38

Overview system components part 2

fischer Highbond-Anchor FHB / FHB N (alternative designation)

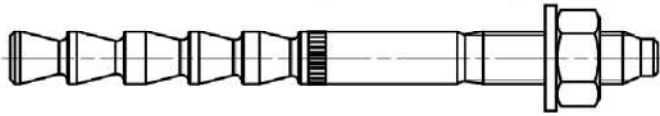

fischer anchor rod FHB-A / FHB-A N; Size: M10x60

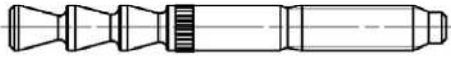

fischer anchor rod FHB-A / FHB-A N; Size: M12x80

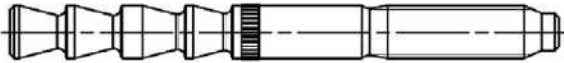

fischer anchor rod FHB-A / FHB-A N; Size: M12x100, M16x125, M20x170, M24x220

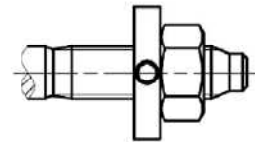
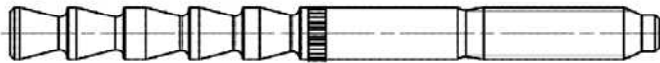

alternative version

fischer Highbond-Anchor dynamic FHB dyn without shear force sleeve (in assembled condition)

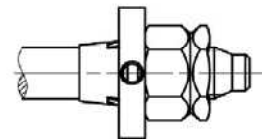
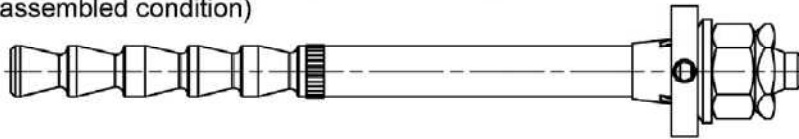

alternative version:
hexagonal nut with
spherical contact surface

fischer Highbond-Anchor dynamic FHB dyn V with shear force sleeve (in assembled condition)

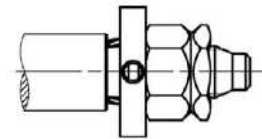
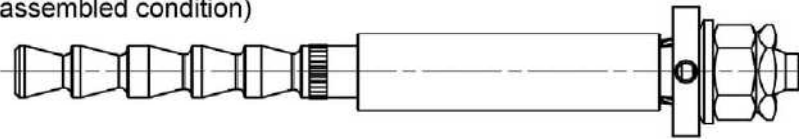

fischer anchor rod FHB-A dyn; Size: M12, M16, M20, M24

alternative

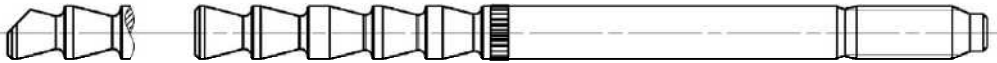

fischer Dynamic-Anchor FDA

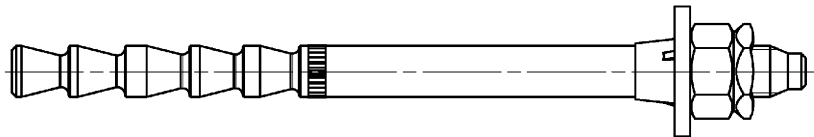

fischer anchor rod FDA-A; Size: M12, M16

alternative

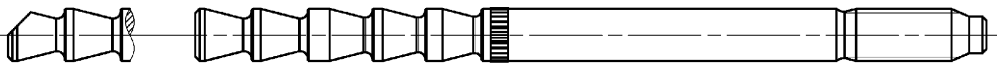

Figures not to scale

fischer Highbond-Anchor FHB / FHB dyn / FDA

Product description

Overview system components part 2
Metal parts

Annex A5

Appendix 7 / 38

Overview system components part 3

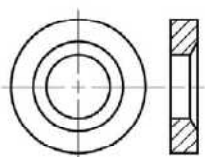
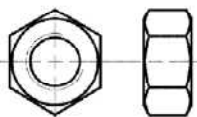
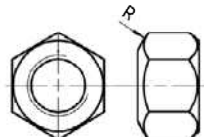
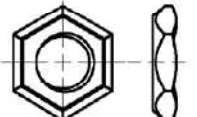
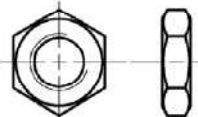
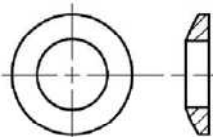
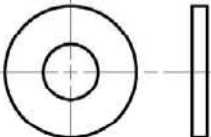
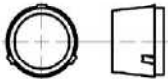
<p>conical washer without drill hole</p> 	<p>fischer filling disc (various versions)</p> <table border="1"> <tr> <td data-bbox="375 90 717 382"> <p>radial</p>  </td> <td data-bbox="717 90 1059 382"> <p>angular</p>  </td> <td data-bbox="1059 90 1410 382"> <p>axial</p>  </td> </tr> </table>			<p>radial</p> 	<p>angular</p> 	<p>axial</p> 
<p>radial</p> 	<p>angular</p> 	<p>axial</p> 				
<p>hexagon nut</p> 	<p>hexagonal nut with spherical contact surface</p> 	<p>lock nut</p> 	<p>hexagon nut, flat</p> 			
<p>spherical washer</p> 	<p>washer</p> 	<p>centering sleeve</p>  <p>only push through installation; FHB dyn and FDA</p>				

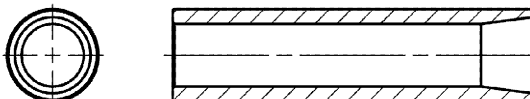
<p>shear force sleeve (only FHB dyn V)</p> 
--

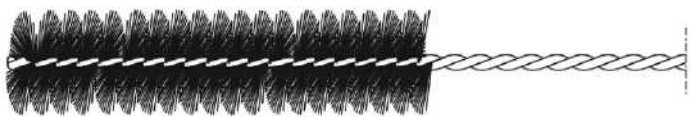
<p>cleaning brush BS</p> 
--

<p>blow-out pump ABP with cleaning nozzle or ABG</p> 
--

Figures not to scale

fischer Highbond-Anchor FHB / FHB dyn / FDA

Product description
Overview system components part 3
Metal parts / cleaning brush / blow-out pump

Annex A6

Appendix 8 / 38

Table A7.1: Dimensions system components, FHB / FHB N

Designation		FHB 10x60	FHB 12x80	FHB 12x100	FHB 16x125	FHB 20x170	FHB 24x220
Thread	[-]	M10	M12	M12	M16	M20	M24
Anchor rod	d	10	12	12	16,5	22	24,5
Conical washer / fischer filling disc	$\geq d_a$	26	30	30	38	46	54
	t_s	6	6	6	7	8	10

Anchor rod:

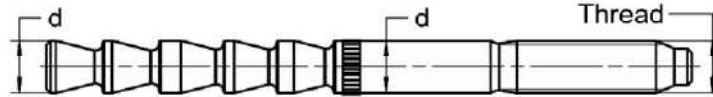

Conical washer /
fischer filling disc:

(various versions see
Annex A6)

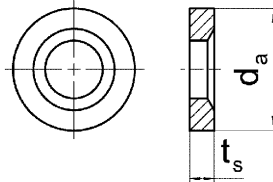

Figures not to scale

fischer Highbond-Anchor FHB / FHB dyn / FDA

Product description
Dimensions system components, FHB / FHB N

Annex A7

Appendix 9 / 38

Table A8.1: Dimensions system components, FHB dyn / FHB dyn V

Designation	[-]	FHB dyn without shear force sleeve				FHB dyn V with shear force sleeve	
		FHB dyn 12x100	FHB dyn 16x125	FHB dyn 20x170	FHB dyn 24x220	FHB dyn 12x100 V	FHB dyn 16x125 V
Thread		M12	M16	M20	M24	M12	M16
Anchor rod	d	12	16,5	22	24,5	12	16,5
	L _{min}	135	168	220	280	140	173
	L _{max}	467	530	575	475	337	367
Centering sleeve	D _z	11,8	16,3	21,8	24,3	11,8	16,3
	L _z	11	13	15	15	11	13
Conical washer / fisher filling disc	≥ d _a	30	38	46	54	30	38
	t _s	6	7	8	10	6	7
Shear force sleeve	L _{Q,min}	-	-	-	-	40	55
	L _{Q,max}	-	-	-	-	230	245
	D _Q	-	-	-	-	17,5	23,5

Anchor rod:

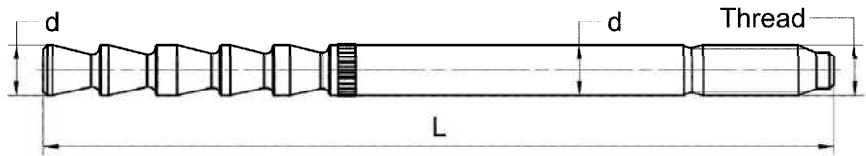

Centering sleeve:
(only push through
installation)

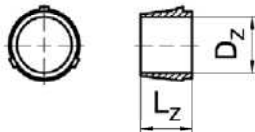

Conical washer /
fisher filling disc:
(various versions see
Annex A6)

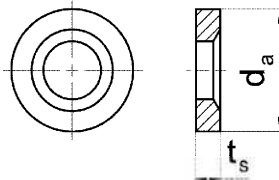

Shear force sleeve:
(only FHB dyn V)

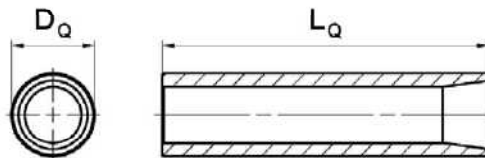

Figures not to scale

fischer Highbond-Anchor FHB / FHB dyn / FDA

Product description
Dimensions system components, FHB dyn / FHB dyn V

Annex A8

Appendix 10 / 38

Table A9.1: Dimensions system components, FDA

Designation		FDA 12x100	FDA 16x125
Thread	[-]	M12	M16
Anchor rod	d	12	16,5
	L _{min}	135	168
	L _{max}	467	530
Centering sleeve	D _z	11,8	16,3
	L _z	11	13
Washer	≥ d _a	30	40
	t _{s,min}	3,5	4
	t _{s,max}	7	8

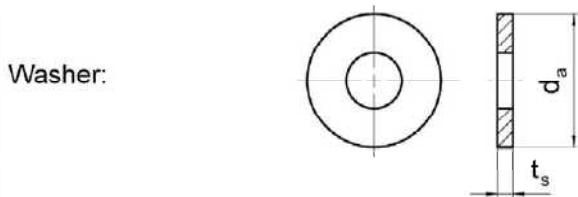
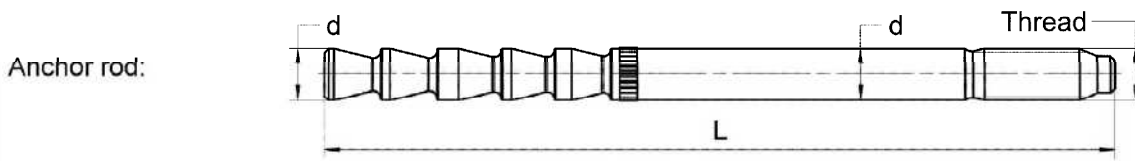

Figures not to scale

fischer Highbond-Anchor FHB / FHB dyn / FDA

Product description
Dimensions system components, FDA

Annex A9
Appendix 11 / 38

Table A10.1: Materials, FHB / FHB N zinc plated (zp; hdg)

Part	Designation	Material		
1	Injection cartridge	Mortar, hardener, filler		
	Steel grade	Steel		
		zinc plated (zp)		hot dip galvanised (hdg)
		M10 to M16	M20 to M24	M10 to M24
2	fischer anchor rod FHB-A and FHB-A N	Property class 5.8 Property class 8.8 EN ISO 898-1:2013 zinc plated $\geq 5 \mu\text{m}$ ISO 4042:2022 $A_5 > 12\%$ fracture elongation coated	$f_{uk} = 550 \text{ N/mm}^2$ $f_{yk} = 440 \text{ N/mm}^2$ EN ISO 898-1:2013 zinc plated $\geq 5 \mu\text{m}$ ISO 4042:2022 $A_5 > 12\%$ fracture elongation coated	Property class 8.8 EN ISO 898-1:2013 hot dip galvanised $\geq 40 \mu\text{m}$ EN ISO 10684:2004+AC:2009 $A_5 > 12\%$ fracture elongation varnish layer coated (M16 to M24)
3	Washer ISO 7089:2000	zinc plated $\geq 5 \mu\text{m}$ ISO 4042:2022		hot dip galvanised $\geq 40 \mu\text{m}$ EN ISO 10684:2004+AC:2009
4	Conical washer or fischer filling disc similar to DIN 6319-G	zinc plated $\geq 5 \mu\text{m}$ ISO 4042:2022		hot dip galvanised $\geq 40 \mu\text{m}$ EN ISO 10684:2004+AC:2009
5	Hexagon nut	Property class 8 EN ISO 898-2:2012 zinc plated $\geq 5 \mu\text{m}$ ISO 4042:2022		Property class 8 EN ISO 898-2:2012 hot dip galvanised $\geq 40 \mu\text{m}$ EN ISO 10684:2004+AC:2009

fischer Highbond-Anchor FHB / FHB dyn / FDA

Product description
Materials, FHB / FHB N zinc plated (zp; hdg)

Annex A10

Appendix 12 / 38

Table A11.1: Materials, FHB / FHB N stainless steel

Part	Designation	Material		
1	Injection cartridge	Mortar, hardener, filler		
	Steel grade	Stainless steel R		High corrosion resistant steel HCR
		acc. to EN 10088-1:2014 Corrosion resistance class CRC III acc. to EN 1993-1-4:2006+A1:2015		acc. to EN 10088-1:2014 Corrosion resistance class CRC V acc. to EN 1993-1-4:2006+A1:2015
		M10 to M16	M20 to M24	M10 to M24
2	fischer anchor rod FHB-A and FHB-A N	Property class 80 EN ISO 3506-1:2020 1.4401; 1.4404; 1.4578; 1.4571; 1.4439; 1.4362; 1.4062, 1.4662, 1.4462; EN 10088-1:2014 A ₅ > 12% fracture elongation coated	Property class 70 with f _{yk} = 560 N/mm ² EN ISO 3506-1:2020 1.4401; 1.4404; 1.4578; 1.4571; 1.4439; 1.4362; 1.4062, 1.4662, 1.4462; EN 10088-1:2014 A ₅ > 12% fracture elongation coated	Property class 70 with f _{yk} = 560 N/mm ² EN ISO 3506-1:2020 1.4565; 1.4529 EN 10088-1:2014 A ₅ > 12% fracture elongation coated
3	Washer ISO 7089:2000	1.4401; 1.4404; 1.4578; 1.4571; 1.4439; 1.4362; EN 10088-1:2014		1.4565; 1.4529; EN 10088-1:2014
4	Conical washer or fischer filling disc similar to DIN 6319-G	1.4401; 1.4404; 1.4578; 1.4571; 1.4439; 1.4362; EN 10088-1:2014		1.4565; 1.4529; EN 10088-1:2014
5	Hexagon nut	Property class 70 or 80 EN ISO 3506-2:2020 1.4401; 1.4404; 1.4578; 1.4571; 1.4439; 1.4362; EN 10088-1:2014		Property class 70 or 80 EN ISO 3506-2:2020 1.4565; 1.4529; EN 10088-1:2014

fischer Highbond-Anchor FHB / FHB dyn / FDA

Product description
Materials, FHB / FHB N stainless steel

Annex A11

Appendix 13 / 38

Table A12.1: Materials, FHB dyn

Part	Designation	Material	
1	Injection cartridge	Mortar, hardener, filler	
	Steel grade	Steel	High corrosion resistant steel HCR
		zinc plated (zp)	acc. to EN 10088-1:2014 Corrosion resistance class CRC V acc. to EN 1993-1-4:2006+A1:2015
		M12 to M24	M12 to M16
2	fischer anchor rod FHB-A dyn	Property class 8.8 EN ISO 898-1:2013 zinc plated $\geq 5 \mu\text{m}$ ISO 4042:2022 $A_5 > 12\%$ fracture elongation coated	Property class 70 with $f_{yk} = 560 \text{ N/mm}^2$ EN ISO 3506-1:2020 1.4529 EN 10088-1:2014 $A_5 > 12 \%$ fracture elongation coated
3	Centering sleeve	Plastic	
4	Conical washer or fischer filling disc similar to DIN 6319-G	zinc plated $\geq 5 \mu\text{m}$ ISO 4042:2022	1.4529 EN 10088-1:2014
5	Spherical washer	zinc plated $\geq 5 \mu\text{m}$ ISO 4042:2022	1.4529 EN 10088-1:2014
6a	Hexagon nut	Property class 8 EN ISO 898-2:2012 zinc plated $\geq 5 \mu\text{m}$ ISO 4042:2022	Property class 70 or 80 EN ISO 3506-2:2020 1.4529 EN 10088-1:2014
6b	hexagonal nut with spherical contact surface		
7a	Lock nut	zinc plated $\geq 5 \mu\text{m}$ ISO 4042:2022	1.4529 EN 10088-1:2014
7b	hexagon nut, flat		
8	Shear force sleeve	zinc plated $\geq 5 \mu\text{m}$ ISO 4042:2022	---

fischer Highbond-Anchor FHB / FHB dyn / FDA

Product description
 Materials, FHB dyn

Annex A12

Appendix 14 / 38

Table A13.1: Materials, FDA

Part	Designation	Material
1	Injection cartridge	Mortar, hardener, filler
	Steel grade	Steel
		zinc plated (zp)
		M12 to M16
2	fischer anchor rod FDA-A	Property class 8.8 EN ISO 898-1:2013 zinc plated $\geq 5 \mu\text{m}$ ISO 4042:2022 $A_5 > 12 \%$ fracture elongation coated
3	Centering sleeve	Plastic
4	Washer	zinc plated $\geq 5 \mu\text{m}$ ISO 4042:2022
5	Hexagon nut	Property class 8 EN ISO 898-2:2012 zinc plated $\geq 5 \mu\text{m}$ ISO 4042:2022
6	Lock nut	zinc plated $\geq 5 \mu\text{m}$ ISO 4042:2022



fischer Highbond-Anchor FHB / FHB dyn / FDA

Product description
Materials, FDA**Annex A13**

Appendix 15 / 38

Specifications of intended use (part 1), FHB / FHB N

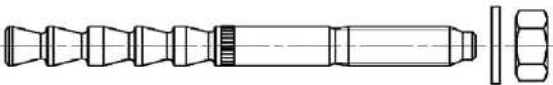
Table B1.1: Overview use and performance categories, FHB / FHB N

		fischer Highbond-Anchor FHB / FHB N with FIS HB	
			
Hammer drilling with standard drill bit		all sizes; Nominal drill bit diameter (d_0) 12 mm to 28 mm	
Hammer drilling with hollow drill bit			
(fischer "FHD"; Heller "Duster Expert"; Bosch "Speed Clean"; Hilti "TE-CD, TE-YD"; DreBo „D-Plus“; DreBo „D-Max“)			
Static and quasi static loading, in concrete without fibers	uncracked concrete	all sizes; M10 to M24	Tables: C1.1 C2.1 C3.1
	cracked concrete		
Static and quasi static loading, in concrete with fibers	uncracked concrete	sizes: M12x100 M16x125	Tables: C1.1 C2.1 C3.2
	cracked concrete		
Use category	I1 dry or wet concrete	all sizes; M10 to M24	
	I2 water filled hole	all sizes; M10 to M24	
Installation direction		D3 Downwards, horizontal and upwards (overhead) installation	
Installation method		pre-positioned or push through installation	
Installation temperature		FIS HB: $T_{i,min} = -5\text{ °C}$ to $T_{i,max} = +40\text{ °C}$ for the standard variation of temperature after installation	
In-service temperature	Temperature range I:	-40 °C to +40 °C	(max. short term temperature +40 °C; max. long term temperature +24 °C)
	Temperature range II:	-40 °C to +80 °C	(max. short term temperature +80 °C; max. long term temperature +50 °C)

fischer Highbond-Anchor FHB / FHB dyn / FDA



Intended use
Specifications (part 1), FHB / FHB N

Annex B1

Appendix 16 / 38

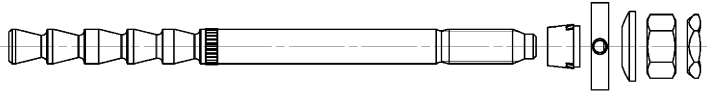
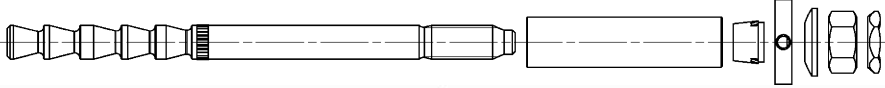

Specifications of intended use (part 2), FHB dyn

Table B2.1: Overview use and performance categories, FHB dyn

		fischer Highbond-Anchor dynamic FHB dyn with FIS HB			
		FHB-A dyn, without shear force sleeve (picture with centering sleeve; use only for push through installation)			
					
		FHB-A dyn V, with shear force sleeve			
					
		FHB dyn		FHB dyn V	
Hammer drilling with standard drill bit		all sizes; Nominal drill bit diameter (d_0) 14 mm to 28 mm		all sizes; Nominal drill bit diameter (d_0) 14 mm and 18 mm Nominal drill bit diameter (d_1) 20 mm and 28 mm	
Hammer drilling with hollow drill bit					
(fischer "FHD", Heller "Duster Expert"; Bosch "Speed Clean"; Hilti "TE-CD, TE-YD"; DreBo „D-Plus“; DreBo „D-Max“)					
Static and quasi static loading, in concrete without fibers	uncracked concrete <hr/> cracked concrete	all sizes; M12 to M24	Tables: C1.1 C2.1 C3.1	all sizes; M12 and M16	Tables: C1.1 C2.1 C3.1
Static and quasi static loading, in concrete with fibers	uncracked concrete <hr/> cracked concrete	sizes: M12x100 M16x125	Tables: C1.1 C2.1 C3.2	sizes: M12x100 M16x125	Tables: C1.1 C2.1 C3.2
Use category	11 dry or wet concrete	all sizes; M12 to M24		all sizes; M12 and M16	
	12 water filled hole	all sizes; M12 to M24		all sizes; M12 and M16	
Installation direction		D3 Downwards, horizontal and upwards (overhead) installation			
Installation method		pre-positioned or push through installation		push through installation	
Installation temperature		FIS HB: $T_{i,min} = -5\text{ °C}$ to $T_{i,max} = +40\text{ °C}$ for the standard variation of temperature after installation			
In-service temperature	Temperature range I:	-40 °C to +40 °C	(max. short term temperature +40 °C; max. long term temperature +24 °C)		
	Temperature range II:	-40 °C to +80 °C	(max. short term temperature +80 °C; max. long term temperature +50 °C)		
fischer Highbond-Anchor FHB / FHB dyn / FDA		Annex B2 Appendix 17 / 38			
Intended use Specifications (part 2), FHB dyn					

Specifications of intended use (part 3), FDA

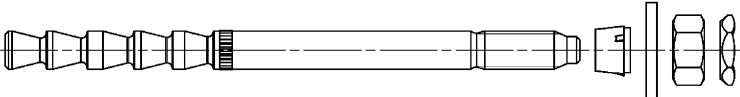
Table B3.1: Overview use and performance categories, FDA

		fischer Dynamic-Anchor FDA with FIS HB	
			
Hammer drilling with standard drill bit		all sizes; Nominal drill bit diameter (d_0) 14 mm and 18 mm	
Hammer drilling with hollow drill bit			
(fischer "FHD"; Heller "Duster Expert"; Bosch "Speed Clean"; Hilti "TE-CD, TE-YD"; DreBo „D-Plus“; DreBo „D-Max“)			
Static and quasi static loading, in concrete without fibers	uncracked concrete	all sizes; M12 and M16	Tables: C1.1 C2.1 C3.1
	cracked concrete		
Static and quasi static loading, in concrete with fibers	uncracked concrete	sizes: M12x100 M16x125	Tables: C1.1 C2.1 C3.2
	cracked concrete		
Use category	I1 dry or wet concrete	all sizes; M12 and M16	
	I2 water filled hole	all sizes; M12 and M16	
Installation direction		D3 Downwards, horizontal and upwards (overhead) installation	
Installation method		push through installation	
Installation temperature		FIS HB: $T_{i,min} = -5\text{ °C}$ to $T_{i,max} = +40\text{ °C}$ for the standard variation of temperature after installation	
In-service temperature	Temperature range I:	-40 °C to +40 °C	(max. short term temperature +40 °C; max. long term temperature +24 °C)
	Temperature range II:	-40 °C to +80 °C	(max. short term temperature +80 °C; max. long term temperature +50 °C)
fischer Highbond-Anchor FHB / FHB dyn / FDA			Annex B3 Appendix 18 / 38
Intended use Specifications (part 3), FDA			

Specifications of intended use (part 4)

Base materials:

- Compacted reinforced or unreinforced normal weight concrete of strength classes C20/25 to C50/60 according to EN 206:2013+A2:2021.
- For steel fibre reinforced concrete according to EN 206:2013+A2:2021 with steel fibers in accordance to EN 14889-1:2006, clause 5, group I. The maximum content of steel fibres is 80 kg/m³.

Use conditions (Environmental conditions):

- Fastener intended for use in structures subject to dry internal conditions (all materials).
- For all other conditions according to EN 1993-1-4: 2006 + A1:2015 corresponding to corrosion resistance classes to Annex A11 table A11.1 (FHB / FHB N) or Annex A12 table A12.1 (FHB dyn).

Design:

- Fastenings have to be designed by a responsible engineer with experience of concrete anchor design.
- Verifiable calculation notes and drawings are to be prepared taking account of the loads to be anchored. The position of the anchor is indicated on the design drawings (e. g. position of the anchor relative to reinforcement or to supports, etc.)
- Fastenings are designed in accordance with:
 - EN 1992-4:2018 and
 - EOTA Technical Report TR 055, Edition February 2018.
- Fastenings in steel fibre reinforced concrete can be designed according to EN 1992-4:2018. The performance for normal weight concrete of strength classes C20/25 to C50/60 without fibres applies.

Installation:

- Fastener installation is to be carried out by appropriately qualified personnel and under the supervision of the person responsible for technical matters of the site.
- Overhead installation is allowed. (necessary equipment see installation instruction).

fischer Highbond-Anchor FHB / FHB dyn / FDA

Intended use
Specifications (part 4)

Annex B4

Appendix 19 / 38

Table B5.1: Installation parameters for fischer Highbond-Anchor FHB / FHB N

Designation		FHB 10x60	FHB 12x80	FHB 12x100	FHB 16x125	FHB 20x170	FHB 24x220		
Thread	[-]	M10	M12	M12	M16	M20	M24		
Nominal drill hole diameter	d_0	12	14	14	18	24	28		
Drill hole depth	h_0	$h_{ef} + 5$							
Effective embedment depth	h_{ef}	60	80	100	125	170	220		
Minimum thickness of concrete member	h_{min}	120	160	130	160	220	440		
Minimum spacing	s_{min}	60	80	100	100	100	100		
Minimum edge distance	c_{min}			200	100	200	100	80	180
Thickness of concrete member	h	≥ 120	≥ 160	≥ 130	≥ 200	≥ 160	≥ 250	≥ 220	≥ 440
$h_{min} \leq h \leq 2h_{ef}$: $s_1 \geq s_{min} = 100$ mm $c_1 \geq c_{min} = 100$ mm		[mm]		[[$(3 \cdot c_1 + s_1) \cdot h$] ≥ 88000					
Calculation c_{req} : s_1 and h available		-		$c_{req} \geq (88000/h - s_1) / 3$				-	
Calculation s_{req} : c_1 and h available		-		$s_{req} \geq 88000/h - 3 \cdot c_1$					
Diameter of clearance hole of the fixture	pre-positioned installation	d_f	12	14	14	18	22	26	
	push through installation	d_f	14	16	16	20	26	30	
Installation torque	T_{inst}	[Nm]	20	40	40	60	100	120	

fischer anchor rod FHB-A / FHB-A N

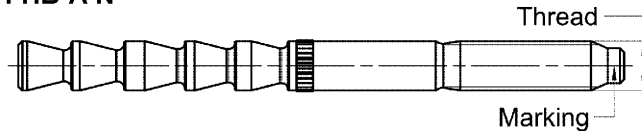

Marking fischer anchor rod:

work symbol, thread diameter, embedment depth e.g.: 16 x 125

For anchor rod property class 5.8 additional "5.8"

For stainless steel additional "R" and for high corrosion resistant steel additional "HCR".

Installation conditions:

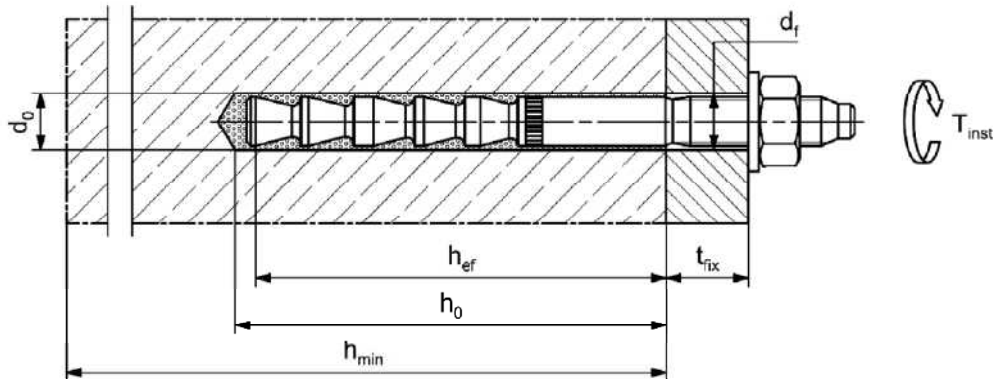

Figures not to scale

fischer Highbond-Anchor FHB / FHB dyn / FDA

Intended use
Installation parameters fischer Highbond-Anchor FHB / FHB N

Annex B5

Appendix 20 / 38

Table B6.1: Installation parameters for fischer Highbond-Anchor dynamic without shear force sleeve FHB dyn

Designation		FHB dyn 12x100	FHB dyn 16x125	FHB dyn 20x170	FHB dyn 24x220
Thread	[-]	M12	M16	M20	M24
Nominal drill hole diameter	d_0	14	18	24	28
Drill hole depth	$h_{0,min}$	$h_{ef} + 5$			
Effective embedment depth	$h_{ef,min}$	100	125	170	220
	$h_{ef,max}$	235	290	330	-
Minimum thickness of concrete member	h_{min}	$h_{ef} + 30$	$h_{ef} + 2d_0$ (160) ¹⁾	$h_{ef} + 2d_0$	440
Minimum spacing	s_{min}	100	100	80	180
Minimum edge distance	c_{min}	200	100	80	180
Thickness of concrete member	h	≥ 130	≥ 200	≥ 160	≥ 250
$h_{min} \leq h \leq 2 h_{ef,min}$: $s_1 \geq s_{min} = 100$ mm $c_1 \geq c_{min} = 100$ mm		[[$(3 \cdot c_1 + s_1) \cdot h$] ≥ 88000			
Calculation c_{req} : (s_1 and h available)		$c_{req} \geq (88000/h - s_1) / 3$			
Calculation s_{req} : (c_1 and h available)		$s_{req} \geq 88000/h - 3 \cdot c_1$			
Diameter of the clearance hole of the fixture	d_f	15	19	25	29
Thickness of fixture	$t_{fix,min}$	8	10	12	14
	$t_{fix,max}$	200			
Minimum projection length	$h_{p,min}$	$30 + t_{fix}$	$35 + t_{fix}$	$40 + t_{fix}$	$50 + t_{fix}$
Installation torque	T_{inst} [Nm]	40	60	100	120

¹⁾ Only valid for $h_{ef} = 125$ mm

fischer anchor rod FHB-A dyn

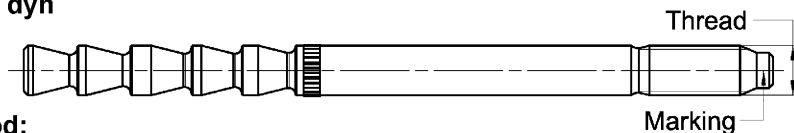

Marking fischer anchor rod:

work symbol, thread diameter, embedment depth, intended use e.g.: $\varnothing 16 \times 125$ dyn
For high corrosion resistant steel additional "HCR".

Installation conditions: (picture without centering sleeve; pre-positioned installation)

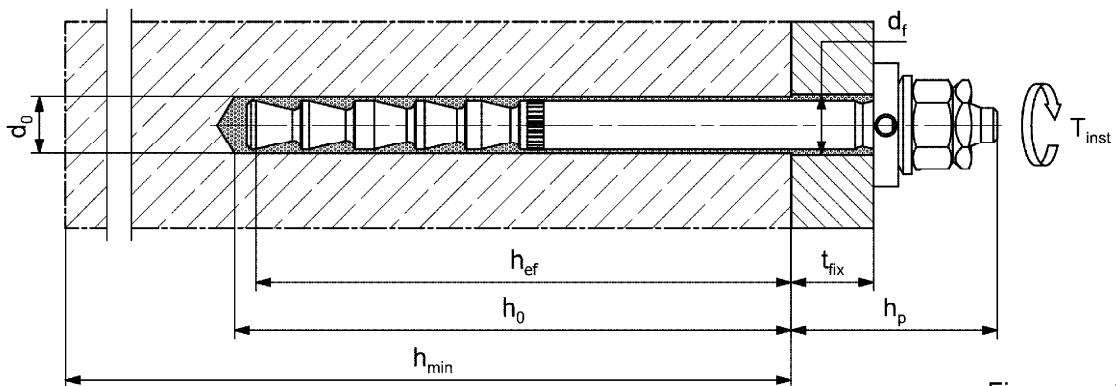

Figures not to scale

fischer Highbond-Anchor FHB / FHB dyn / FDA

Intended use
Installation parameters fischer Highbond-Anchor dynamic FHB dyn
(without shear force sleeve)

Annex B6

Appendix 21 / 38

Table B7.1: Installation parameters for fischer Highbond-Anchor dynamic with shear force sleeve FHB dyn V

Designation		FHB dyn 12x100 V		FHB dyn 16x125 V	
Thread	[-]	M12		M16	
Nominal drill hole diameter	d_0	14		18	
Drill hole depth	$h_{0,min}$	110		135	
Nominal drill hole diameter	d_1	20		28	
Drill hole depth	$h_{1,min}$	35		50	
Effective embedment depth	h_{ef}	105		130	
Minimum thickness of concrete member	h_{min}	130		160	
Minimum spacing	s_{min}	100	100	100	100
Minimum edge distance	c_{min}	200	100	200	100
Thickness of concrete member	h	≥ 130	≥ 200	≥ 160	≥ 250
$h_{min} \leq h \leq 2h_{ef}$: $s_1 \geq s_{min} = 100 \text{ mm}$ $c_1 \geq c_{min} = 100 \text{ mm}$	[mm]	$[(3 \cdot c_1 + s_1) \cdot h] \geq 88000$			
Calculation c_{req} : s_1 and h available		$c_{req} \geq (88000/h - s_1) / 3$			
Calculation s_{req} : c_1 and h available		$s_{req} \geq 88000/h - 3 \cdot c_1$			
Diameter of the clearance hole of the fixture	d_f	21		29	
Thickness of fixture	$t_{fix,min}$	8		10	
	$t_{fix,max}$	200			
Installation torque	T_{inst}	[Nm]	40	60	

fischer anchor rod FHB-A dyn V (picture without shear force sleeve)

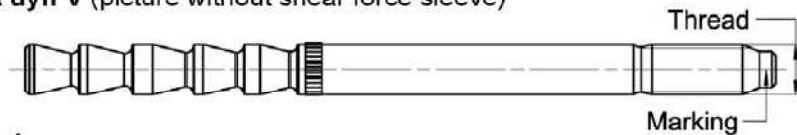

Marking fischer anchor rod:

work symbol, thread diameter, embedment depth, intended use e.g.: \oslash 16 x 125 dyn V

Installation conditions:

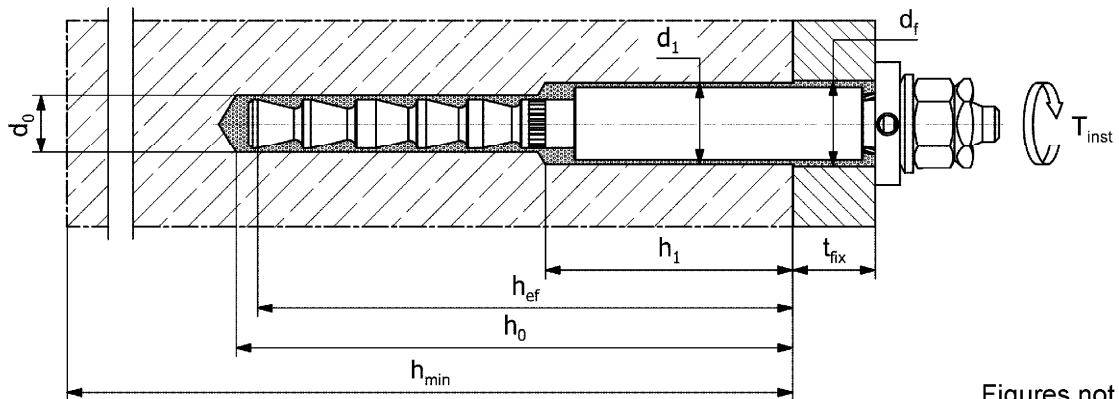

Figures not to scale

fischer Highbond-Anchor FHB / FHB dyn / FDA

Intended use

Installation parameters fischer Highbond-Anchor dynamic FHB dyn V (with shear force sleeve)

Annex B7

Appendix 22 / 38

Table B8.1: Installation parameters for fischer Dynamic-Anchor FDA

Designation		FDA 12x100		FDA 16x125	
Thread	[-]	M12		M16	
Nominal drill hole diameter	d_0	14		18	
Drill hole depth	$h_{0,min}$	$h_{ef} + 5$			
Effective embedment depth	$h_{ef,min}$	100		125	
	$h_{ef,max}$	235		290	
Minimum thickness of concrete member	h_{min}	$h_{ef} + 30$		$h_{ef} + 2d_0$ (160) ¹⁾	
Minimum spacing	s_{min}	100	100	100	100
Minimum edge distance	c_{min}	200	100	200	100
Thickness of concrete member	h	≥ 130	≥ 200	≥ 160	≥ 250
$h_{min} \leq h \leq 2h_{ef,min}$: $s_1 \geq s_{min} = 100$ mm $c_1 \geq c_{min} = 100$ mm	[mm]	$[(3 \cdot c_1 + s_1) \cdot h] \geq 88000$			
Calculation c_{req} : s_1 and h available		$c_{req} \geq (88000/h - s_1) / 3$			
Calculation s_{req} : c_1 and h available		$s_{req} \geq 88000/h - 3 \cdot c_1$			
Diameter of the clearance hole of the fixture	d_f	15		19	
Thickness of fixture	$t_{fix,min}$	12		16	
	$t_{fix,max}$	200			
Installation torque	T_{inst}	[Nm]	40	60	

¹⁾ Only valid for $h_{ef} = 125$ mm

fischer anchor rod FDA-A

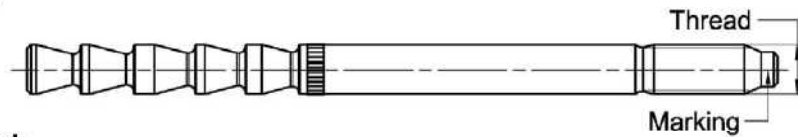

Marking fischer anchor rod:

work symbol, thread diameter, embedment depth, intended use e.g.: 16 x 125 dyn

Installation conditions:

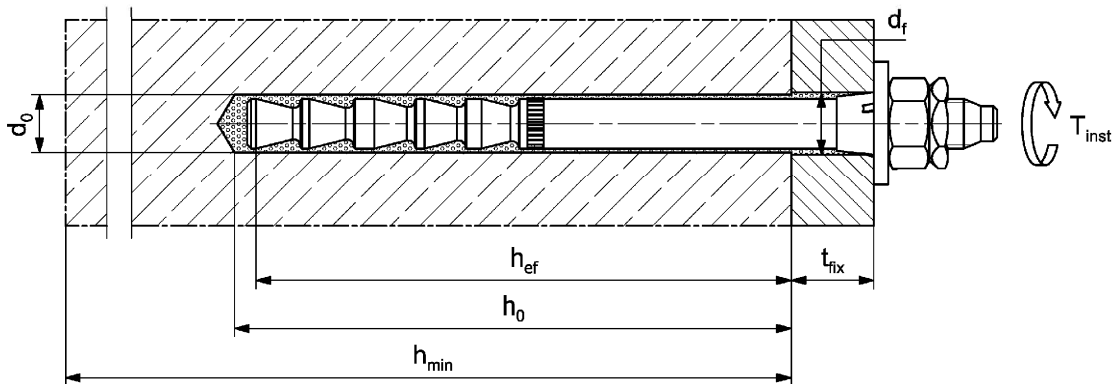

Figures not to scale

fischer Highbond-Anchor FHB / FHB dyn / FDA

Intended use
Installation parameters fischer Dynamic-Anchor FDA

Annex B8

Appendix 23 / 38

Table B9.1: Parameters of the cleaning brush BS (steel brush with steel bristles)

The size of the cleaning brush refers to the drill hole diameter

Nominal drill hole diameter	d_0	[mm]	12	14	18	24	28
Steel brush diameter	d_b		14	16	20	26	30

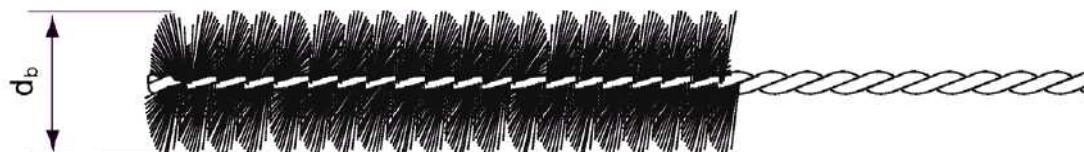

Table B9.2: Maximum processing time of the mortar FIS HB and minimum curing time (During the curing time of the mortar the concrete temperature may not fall below the listed minimum temperature)

Temperature at anchoring base [°C]	Maximum processing time t_{work}	Minimum curing time t_{cure} ¹⁾
-5 to 0 ²⁾	15 min	6 h
> 0 to 5 ²⁾	15 min	3 h
> 5 to 10	15 min	90 min
> 10 to 20	6 min	35 min
> 20 to 30	4 min	20 min
> 30 to 40	2 min	12 min

¹⁾ In wet concrete or water filled holes the curing time must be doubled.

²⁾ Minimal cartridge temperature +5 °C.

Figures not to scale

fischer Highbond-Anchor FHB / FHB dyn / FDA

Intended use
Parameters of the cleaning brush (steel brush);
Processing time and curing time

Annex B9

Appendix 24 / 38

Overview installation instructions

	Anchor type			
	FHB / FHB N	FHB dyn	FHB dyn V	FDA
Drilling and cleaning hammer drilling with standard drill bit	Annex B11 Step 1a to 4a	Annex B11 Step 1a to 4a	Annex B12 Step 1c to 4c	Annex B11 Step 1a to 4a
Drilling and cleaning hammer drilling with hollow drill bit	Annex B11 Step 1b to 2b	Annex B11 Step 1b to 2b	Annex B12 Step 1d to 2d	Annex B11 Step 1b to 2b
Preparing the cartridge	Annex B13 Step 5a to 7a			
Pre-positioned installation	Annex B14 Step 8a to 12a	Annex B16 Step 8c to 12c	-	-
Push through installation	Annex B15 Step 8b to 11b	Annex B17 Step 8d to 11d	Annex B18 Step 8e to 11e	Annex B19 Step 8f to 11f

fischer Highbond-Anchor FHB / FHB dyn / FDA





Intended use
Overview installation instructions

Annex B10

Appendix 25 / 38

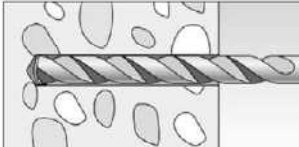
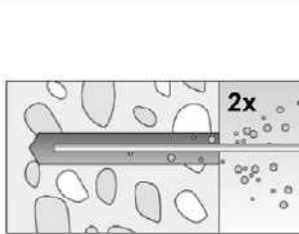
Installation instructions part 1; Drilling and cleaning FHB, FHB N, FHB dyn and FDA

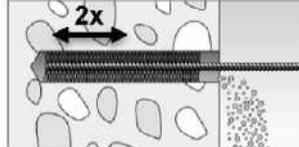
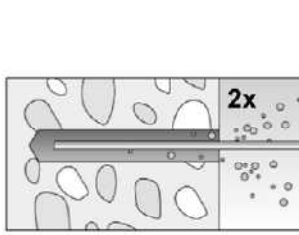
Drilling and cleaning the drill hole (hammer drilling with standard drill bit)

1a		<p>Drill the hole. Nominal drill hole diameter d_0 and drill hole depth h_0 see tables: FHB / FHB N → Table B5.1 FHB dyn → Table B6.1 FDA → Table B8.1</p>
2a		<p>Clean the drill hole. Blow out the drill hole twice</p> <p>For drill hole diameter $d_0 < 24$ mm and drill hole depth $h_0 < 10d$ blow out the hole by hand or oil-free compressed air (≥ 6 bar).</p> <p>For drill hole diameter $d_0 \geq 24$ mm or drill hole depth $h_0 \geq 10d$ blow out the hole with oil-free compressed air (≥ 6 bar).</p> <p>Use a cleaning nozzle.</p> 
3a		<p>Brush the drill hole twice with steel brush. Corresponding brushes see Table B9.1</p>
4a		<p>Clean the drill hole. Blow out the drill hole twice</p> <p>For drill hole diameter $d_0 < 24$ mm and drill hole depth $h_0 < 10d$ blow out the hole by hand or oil-free compressed air (≥ 6 bar).</p> <p>For drill hole diameter $d_0 \geq 24$ mm or drill hole depth $h_0 \geq 10d$ blow out the hole with oil-free compressed air (≥ 6 bar).</p> <p>Use a cleaning nozzle.</p> 

Go to step 5a (Annex B13)

Drilling and cleaning the drill hole (hammer drilling with hollow drill bit)

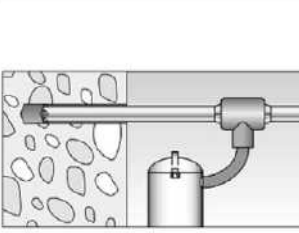
1b		<p>Check a suitable hollow drill (see Table B1.1, B2.1 resp. B3.1) for correct operation of the dust extraction</p>
2b		<p>Use a suitable dust extraction system, e.g. fischer FVC 35 M or a comparable dust extraction system with equivalent performance data.</p> <p>Drill the hole with hollow drill bit. The dust extraction system has to extract the drill dust nonstop during the drilling process and must be adjusted to maximum power.</p> <p>Nominal drill hole diameter d_0 and drill hole depth h_0 see tables: FHB / FHB N → Table B5.1 FHB dyn → Table B6.1 FDA → Table B8.1</p>

Go to step 5a (Annex B13)

fischer Highbond-Anchor FHB / FHB dyn / FDA





Intended use
Installation instructions part 1
Drilling and cleaning the drill hole FHB, FHB N, FHB dyn and FDA

Annex B11

Appendix 26 / 38

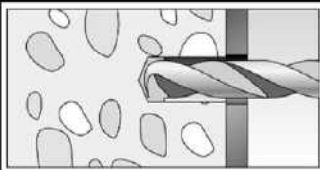
Installation instructions part 2; Drilling and cleaning FHB dyn V

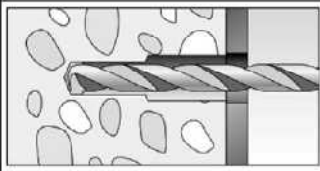
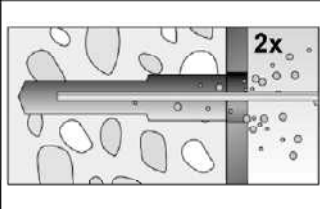
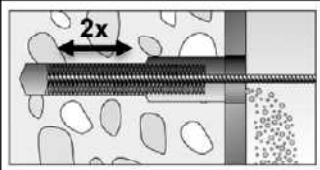
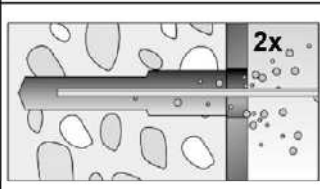
Drilling and cleaning the hole (hammer drilling with standard drill bit)

1c		<p>Drill hole 1 of the stepped borehole. Nominal drill hole diameter d_1 and drill hole depth h_1 see Table B7.1</p>	
		<p>Drill hole 2 of the stepped borehole. Nominal drill hole diameter d_0 and drill hole depth h_0 see Table B7.1</p>	
2c		<p>Clean the drill hole. Blow out the drill hole twice by hand or oil-free compressed air (≥ 6 bar).</p>	
3c		<p>Brush the drill hole 2 of the borehole twice with a steel brush. Corresponding brushes see Table B9.1</p>	
4c		<p>Clean the drill hole. Blow out the drill hole twice by hand or oil-free compressed air (≥ 6 bar).</p>	

Go to step 5a (Annex B13)

Drilling and cleaning the hole (hammer drilling with hollow drill bit)

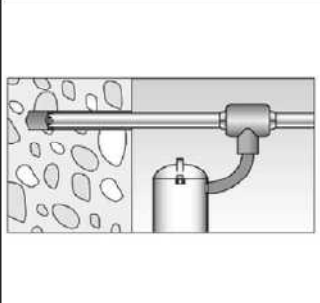
1d		<p>Check a suitable hollow drill (see Table B2.1) for correct operation of the dust extraction.</p>	
2d		<p>Use a suitable dust extraction system, e.g. fischer FVC 35 M or a comparable dust extraction system with equivalent performance data.</p> <p>Drill the hole with hollow drill bit. The dust extraction system has to extract the drill dust nonstop during the drilling process and must be adjusted to maximum power.</p> <p>First drill hole 1 of the stepped borehole with nominal drill hole diameter d_1 and drill hole depth h_1 (see Table B7.1).</p> <p>Then drill hole 2 of the stepped borehole with nominal drill hole diameter d_0 and drill hole depth h_0 (see Table B7.1).</p>	

Go to step 5a (Annex B13)

fischer Highbond-Anchor FHB / FHB dyn / FDA





Intended use
Installation instructions part 2
Drilling and cleaning the drill hole FHB dyn V

Annex B12

Appendix 27 / 38

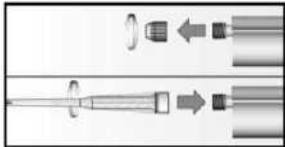
Installation instructions part 3; injection mortar system FIS HB

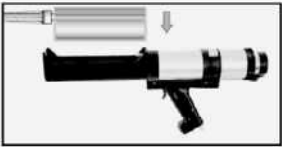
Preparing the cartridge

5a		Remove the sealing cap Screw on the static mixer (the spiral in the static mixer must be clearly visible)	
6a			Place the cartridge into the dispenser
7a			Extrude approximately 10 cm of material out until the resin is evenly grey in colour. Do not use mortar that is not uniformly grey

Go to step:

- 8a: FHB / FHB N - Pre-positioned installation see Annex B14
- 8b: FHB / FHB N - Push through installation see Annex B15
- 8c: FHB dyn - Pre-positioned installation see Annex B16
- 8d: FHB dyn - Push through installation see Annex B17
- 8e: FHB dyn V - Push through installation see Annex B18
- 8f: FDA - Push through installation see Annex B19



fischer Highbond-Anchor FHB / FHB dyn / FDA

Intended use
Installation instructions part 3
Preparing the cartridge

Annex B13
Appendix 28 / 38

Installation instructions part 4; Pre-positioned installation FHB / FHB N

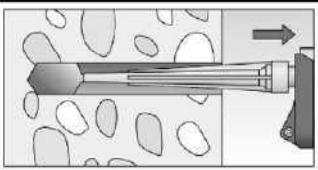
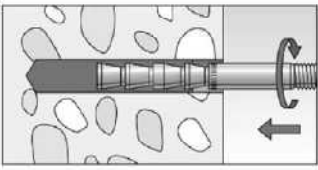
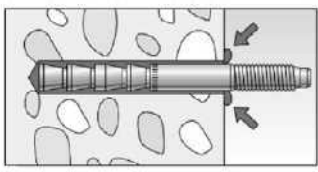
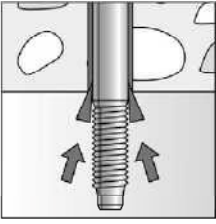
Pre-positioned installation FHB / FHB N

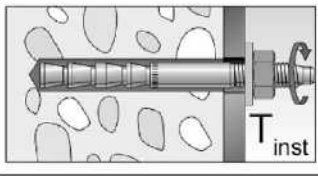
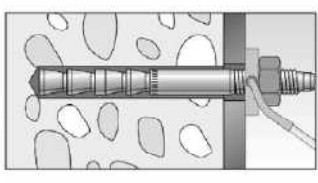
8a		<p>Fill approximately 2/3 of the drill hole with mortar. Always begin from the bottom of the hole and avoid bubbles. For drill hole depth $h_0 \geq 150$ mm use an extension tube. For overhead installation or deep holes ($h_0 > 250$ mm) use an injection adapter.</p>
		<p>Push the anchor rod down to the bottom of the hole, turning it slightly while doing so. Only use clean and oil-free metal parts.</p>
9a	 	<p>After inserting the anchor rod, excess mortar must be emerged around the anchor element. If not, pull out the anchor rod immediately and reinject mortar.</p> <p>For overhead installations support the anchor rod with wedges. (e.g. fischer centering wedges).</p>
10a		<p>Wait for the specified curing time t_{cure} see Table B9.2.</p>
11a		<p>Attach the fixture and install the washer and hexagon nut. Ensure the correct position of the metal parts. Tighten the hexagon nut with installation torque T_{inst} (see Table B5.1).</p>
12a Option		<p>The gap between metal parts and fixture (annular gap) may be filled with mortar (FIS HB) via the fischer filling disc. ATTENTION: Using fischer filling disc reduces t_{fix} (usable length of the anchor)</p>

fischer Highbond-Anchor FHB / FHB dyn / FDA



Intended use
Installation instructions part 4
Pre-positioned installation FHB / FHB N

Annex B14

Appendix 29 / 38

Installation instructions part 5; Push through installation FHB / FHB N

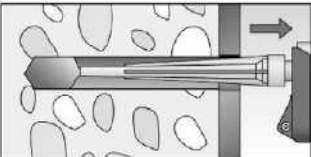
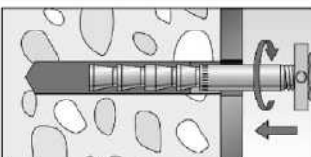
Push through installation FHB / FHB N

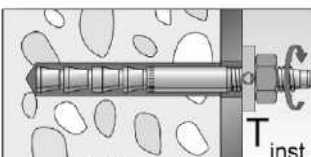
8b		<p>Fill approximately 2/3 of the drill hole incl. fixture with mortar. Always begin from the bottom of the hole and avoid bubbles. For drill hole depth $h_0 \geq 150$ mm use an extension tube. For overhead installation or deep holes ($h_0 > 250$ mm) use an injection adapter.</p>
9b	 	<p>Push the pre-assembled fischer anchor rod (with washer and hexagon nut) into the drill hole until the fischer filling disc is in full contact with the surface, turning it slightly while doing so. Ensure the correct position of the metal parts. Only use clean and oil-free metal parts.</p> <p>After inserting the pre-assembled anchor rod, excess mortar has to emerge under the washer. If not, pull out the assembled anchor rod immediately and reinject mortar.</p>
10b		<p>Wait for the specified curing time t_{cure} see Table B9.2.</p>
11b		<p>Tighten the hexagon nut with installation torque T_{inst} (see Table B5.1).</p>





fischer Highbond-Anchor FHB / FHB dyn / FDA

Intended use
Installation instructions part 5
Push through installation FHB / FHB N

Annex B15
Appendix 30 / 38

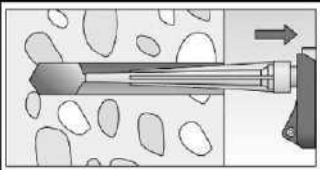
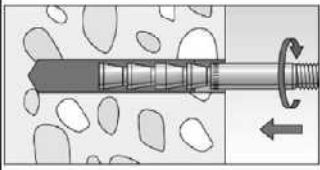
Installation instructions part 6; Pre-positioned installation FHB dyn

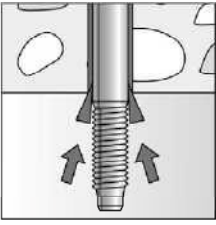
Pre-positioned installation FHB dyn

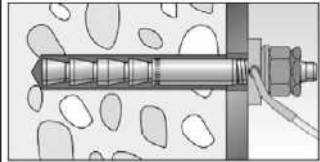
8c		<p>Fill approximately 2/3 of the drill hole with mortar. Always begin from the bottom of the hole and avoid bubbles. For drill hole depth $h_0 \geq 150$ mm use an extension tube. For overhead installation or deep holes ($h_0 > 250$ mm) use an injection adapter.</p>
		<p>Push the anchor rod down to the bottom of the hole, turning it slightly while doing so. Observe projection length h_p (see Table B6.1) Only use clean and oil-free metal parts.</p>
9c	 	<p>After inserting the anchor rod, excess mortar must be emerged around the anchor element. If not, pull out the anchor rod immediately and reinject mortar.</p> <p>For overhead installations support the anchor rod with wedges. (e.g. fischer centering wedges)</p>
10c		<p>Wait for the specified curing time t_{cure} see Table B9.2</p>
11c		<p>Attach the fixture and install the fischer filling disc, the spherical washer and nuts (without centering sleeve). Ensure the correct position of the metal parts. Tighten the hexagon nut with installation torque T_{inst} (see Table B6.1). Tighten lock nut manually, then use wrench to give another quarter or half turn. In the high corrosion resistant steel version, the lock nut is a thin nut. Tighten it with a torque of $\frac{1}{4} T_{inst}$.</p>
12c		<p>The gap between metal parts and fixture (annular gap) has to be filled with mortar (FIS HB) via the fischer filling disc. This installation step can be omitted for anchors with pure tension loading.</p>

fischer Highbond-Anchor FHB / FHB dyn / FDA



Intended use
Installation instructions part 6
Pre-positioned installation FHB dyn

Annex B16

Appendix 31 / 38

Installation instructions part 7; Push through installation FHB dyn

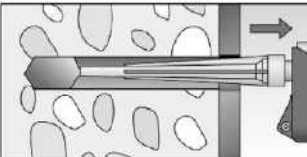
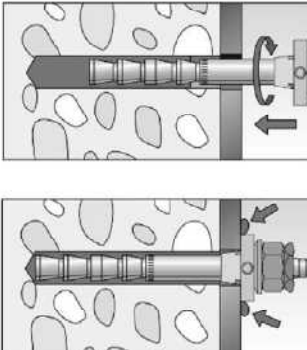
Push through installation FHB dyn

8d		<p>Fill approximately 2/3 of the drill hole incl. fixture with mortar. Always begin from the bottom of the hole and avoid bubbles. For drill hole depth $h_0 \geq 150$ mm use an extension tube. For overhead installation or deep holes ($h_0 > 250$ mm) use an injection-adapter.</p>
9d		<p>Push the pre-assembled fischer anchor rod (with centering sleeve, fischer filling disc, spherical washer, hexagon nut and lock nut) into the drill hole until the fischer filling disc is in full contact with the surface, turning it slightly while doing so. Ensure the correct position of the metal parts and the centering sleeve. Only use clean and oil-free metal parts.</p> <p>After inserting the pre-assembled anchor rod, excess mortar must be emerged around the fischer filling disc (minimum on one point). If not, pull out the assembled anchor rod immediately and reinject mortar.</p>
10d		<p>Wait for the specified curing time t_{cure} see Table B9.2.</p>
11d		<p>Tighten the hexagon nut with installation torque T_{inst} (see Table B6.1). Tighten lock nut manually, then use wrench to give another quarter to half turn. In the high corrosion resistant steel version, the lock nut is a thin nut. Tighten it with a torque of $\frac{1}{4} T_{inst}$.</p>



fischer Highbond-Anchor FHB / FHB dyn / FDA

Intended use
Installation instructions part 7
Push through installation FHB dyn

Annex B17
Appendix 32 / 38

Installation instructions part 8; Push through installation FHB dyn V

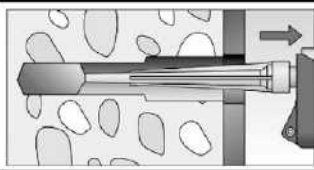
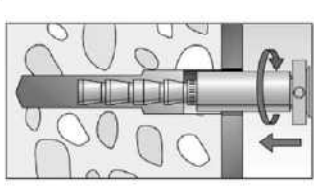
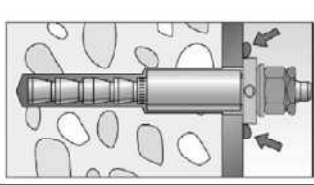
Push through installation FHB dyn V

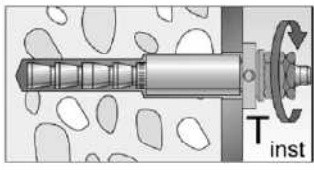
8e		<p>Fill approximately 2/3 of the drill hole incl. fixture with mortar. Always begin from the bottom of the hole and avoid bubbles. For drill hole depth $h_0 \geq 150$ mm use an extension tube. For overhead installation or deep holes ($h_0 > 250$ mm) use an injection adapter.</p>
9e	 	<p>Push the pre-assembled fischer anchor rod (with shear force sleeve, centering sleeve, fischer filling disc, spherical washer, hexagon nut and lock nut) into the drill hole until the fischer filling disc is in full contact with the surface, turning it slightly while doing so. Ensure the correct position of the metal parts and the centering sleeve. Only use clean and oil-free metal parts.</p> <p>After inserting the pre-assembled anchor rod, excess mortar must be emerged around the fischer filling disc (minimum on one point). If not, pull out the assembled anchor rod immediately and reinject mortar.</p>
10e		<p>Wait for the specified curing time t_{cure} see Table B9.2.</p>
11e		<p>Tighten the hexagon nut with installation torque T_{inst} (see Table B7.1). Tighten lock nut manually, then use wrench to give another quarter to half turn.</p>

fischer Highbond-Anchor FHB / FHB dyn / FDA

Intended use



Installation instructions part 8
Push through installation FHB dyn V

Annex B18

Appendix 33 / 38

Installation instructions part 9; Push through installation FDA

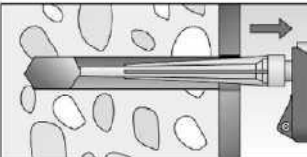
Push through installation FDA

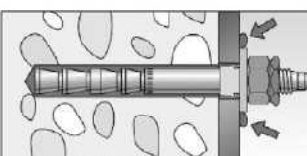
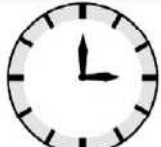
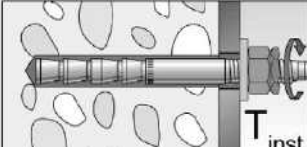
8f		<p>Fill approximately 2/3 of the drill hole incl. fixture with mortar. Always begin from the bottom of the hole and avoid bubbles. For drill hole depth $h_0 \geq 150$ mm use an extension tube. For overhead installation or deep holes ($h_0 > 250$ mm) use an injection adapter.</p>
9f	 	<p>Push the pre-assembled fischer anchor rod (with centering sleeve, washer, hexagon nut and lock nut) into the drill hole until the washer is in full contact with the surface, turning it slightly while doing so. Gently hammer the anchor to the setting depth. Ensure the correct position of the metal parts and the centering sleeve. Only use clean and oil-free metal parts.</p> <p>After inserting the pre-assembled anchor rod, excess mortar must be emerged under the entire washer. If not, pull out the assembled anchor rod immediately and reinject mortar.</p>
10f		<p>Wait for the specified curing time t_{cure} see Table B9.2.</p>
11f		<p>Tighten the hexagon nut with installation torque T_{inst} (see Table B8.1). Tighten lock nut manually, then use wrench to give another quarter to half turn.</p>

fischer Highbond-Anchor FHB / FHB dyn / FDA

Intended use
Installation instructions part 9
Push through installation FDA

Annex B19

Appendix 34 / 38

Table C1.1: Characteristic resistance to steel failure under tension / shear loading for fischer anchor rods FHB-A / FHB-A N / FHB-A dyn (V) / FDA

Anchor rod size			10x60	12x80	12x100	16x125	20x170	24x220		
Characteristic resistance to steel failure under tension loading										
Characteristic resistance $N_{Rk,s}$	FHB-A / FHB-A N	zp	8.8	[kN]	25,8	44,3	44,3	81,7	130,8 ²⁾	179,8 ²⁾
		zp	5.8		16,1	27,7	27,7	51,1	- ³⁾	- ³⁾
		hdg	8.8		25,8	44,3	44,3	81,7	190,2	261,5
		R	80		25,8	44,3	44,3	81,7	166,5 ⁴⁾	228,8 ⁴⁾
		HCR	70		22,5	38,8	38,8	71,5	166,5	228,8
	FHB-A dyn	zp	8.8		- ³⁾	- ³⁾	44,3	81,7	190,2	261,5
		HCR	70		- ³⁾	- ³⁾	38,8	71,5	- ³⁾	- ³⁾
	FHB-A dyn V	zp	8.8		- ³⁾	- ³⁾	44,3	81,7	- ³⁾	- ³⁾
	FDA	zp	8.8		- ³⁾	- ³⁾	44,3	81,7	- ³⁾	- ³⁾

Partial factors ¹⁾

Partial factor	$\gamma_{Ms,N}$	[-]	1,50
----------------	-----------------	-----	------

Characteristic resistance to steel failure under shear loading

without lever arm

Characteristic resistance $V^0_{Rk,s}$	FHB-A / FHB-A N	zp	8.8	[kN]	16,6	28,1	28,1	52,2	61,1 ²⁾	90,8 ²⁾
		zp	5.8		10,4	17,6	17,6	32,7	- ³⁾	- ³⁾
		hdg	8.8		16,6	28,1	28,1	52,2	98,0	141,2
		R	80		24,8	32,8	32,8	62,8	85,8 ⁴⁾	152,6 ⁴⁾
		HCR	70		25,1	36,9	36,9	55,0	85,8	141,1
	FHB-A dyn	zp	8.8		- ³⁾	- ³⁾	28,1	52,2	98,0	141,2
		HCR	70		- ³⁾	- ³⁾	36,9	55,0	- ³⁾	- ³⁾
	FHB-A dyn V	zp	8.8		- ³⁾	- ³⁾	56,9	96,2	- ³⁾	- ³⁾
	FDA	zp	8.8		- ³⁾	- ³⁾	28,1	52,2	- ³⁾	- ³⁾

Ductility factor	k_7	[-]	1,0
------------------	-------	-----	-----

with lever arm

Characteristic resistance $M^0_{Rk,s}$	FHB-A / FHB-A N	zp	8.8	[Nm]	59,8	104,8	104,8	266,4	357,0 ²⁾	617,4 ²⁾
		zp	5.8		37,4	65,5	65,5	166,5	- ³⁾	- ³⁾
		hdg	8.8		59,8	104,8	104,8	266,4	519,3	898,0
		R	80		59,8	104,8	104,8	266,4	454,4 ⁴⁾	785,8 ⁴⁾
		HCR	70		52,3	91,7	91,7	233,1	454,4	785,8
	FHB-A dyn	zp	8.8		- ³⁾	- ³⁾	104,8	266,4	519,3	898,0
		HCR	70		- ³⁾	- ³⁾	91,7	233,1	- ³⁾	- ³⁾
	FHB-A dyn V	zp	8.8		- ³⁾	- ³⁾	104,8	266,4	- ³⁾	- ³⁾
	FDA	zp	8.8		- ³⁾	- ³⁾	104,8	266,4	- ³⁾	- ³⁾

Partial factors ¹⁾

Partial factor	$\gamma_{Ms,V}$	[-]	1,25
----------------	-----------------	-----	------

¹⁾ In absence of other national regulations

²⁾ $f_{yk} = 440 \text{ N/mm}^2 / f_{uk} = 550 \text{ N/mm}^2$

³⁾ No performance assessed

⁴⁾ $f_{yk} = 560 \text{ N/mm}^2 / f_{uk} = 700 \text{ N/mm}^2$

fischer Highbond-Anchor FHB / FHB dyn / FDA

Performance

Characteristic resistance to steel failure under tension / shear loading for fischer anchor rods FHB-A / FHB-A N / FHB-A dyn (V) / FDA

Annex C1

Appendix 35 / 38

Table C2.1: Characteristic resistance to concrete failure under tension / shear loading

		FHB / FHB N / FHB dyn (V) / FDA									
Size		All sizes									
Tension loading											
Installation factor	γ_{inst}	[-]	See Annex C3								
Factors for the compressive strength of concrete > C20/25											
Increasing factor Ψ_c for concrete $N_{Rk,p (X,Y)} =$ $\Psi_c \cdot N_{Rk,p (C20/25)}$	C25/30	Ψ_c	[-]	1,10							
	C30/37			1,22							
	C35/45			1,34							
	C40/50			1,41							
	C45/55			1,48							
	C50/60			1,55							
Splitting failure											
Edge distance	$c_{cr,sp}$	[mm]	2 h_{ef}								
Spacing	$s_{cr,sp}$		2 $c_{cr,sp}$								
Concrete failure											
Uncracked concrete	$k_{ucr,N}$	[-]	11,0								
Cracked concrete	$k_{cr,N}$		7,7								
Edge distance	$c_{cr,N}$	[mm]	1,5 h_{ef}								
Spacing	$s_{cr,N}$		2 $c_{cr,N}$								
Shear loading											
Installation factor	γ_{inst}	[-]	1,0								
Concrete pry-out failure											
Factor for pry-out failure	k_8	[-]	2,0								
Concrete edge failure											
Anchor size			10x60	12x80	12x100	12x100 V	16x125	16x125 V	20x170	24x220	
Effective length of anchor	l_f	[mm]	60	80	100	105	125	130	170	220	
Effective diameter of the fastener	d_{nom}		12	14	14	20	18	28	24	28	
fischer Highbond-Anchor FHB / FHB dyn / FDA										Annex C2 Appendix 36 / 38	
Performance Characteristic resistance to concrete failure under tension / shear loading											

Table C3.1: Characteristic resistance to pull-out failure for fischer anchor rods FHB-A / FHB-A N / FHB-A dyn (V) / FDA in compacted reinforced or unreinforced normal weight concrete **without fibers**

Anchor rod size			10x60	12x80	12x100	16x125	20x170	24x220		
Pull-out failure										
Calculation diameter	d	[mm]	10	12	12	16	20	24		
Uncracked concrete										
Characteristic resistance in uncracked concrete C20/25										
Temperature range	I: 24 °C / 40 °C		N _{Rk,p}	[kN]	26,9	41,3	42,1	70,5	113,6	122,2
	II: 50 °C / 80 °C				23,7	36,3	37,0	62,0	100,0	107,5
Cracked concrete										
Characteristic resistance in cracked concrete C20/25										
Temperature range	I: 24 °C / 40 °C		N _{Rk,p}	[kN]	15,5	25,0	30,0	47,8	58,9	89,4
	II: 50 °C / 80 °C				13,6	22,0	26,4	42,1	51,8	78,7
Installation factors										
Dry or wet concrete	γ _{inst}	[-]	1,0							
Water filled hole			1,0	1,0	1,0	1,2	1,0	1,0		

Table C3.2: Characteristic resistance to pull-out failure for fischer anchor rods FHB-A / FHB-A N / FHB-A dyn (V) / FDA in compacted reinforced or unreinforced normal weight concrete **with fibers**

Anchor rod size			12x100			16x125			
Pull-out failure									
Calculation diameter	d	[mm]	12			16			
Uncracked concrete									
Characteristic resistance in uncracked concrete C20/25									
Temperature range	I: 24 °C / 40 °C		N _{Rk,p}	[kN]	42,1			70,5	
	II: 50 °C / 80 °C				37,0			62,0	
Cracked concrete									
Characteristic resistance in cracked concrete C20/25									
Temperature range	I: 24 °C / 40 °C		N _{Rk,p}	[kN]	30,0			47,8	
	II: 50 °C / 80 °C				26,4			42,1	
Installation factors									
Dry or wet concrete	γ _{inst}	[-]	1,0						
Water filled hole			1,0			1,2			

**Table C4.1: Displacements for fischer anchor rods
FHB-A / FHB-A N / FHB-A dyn (V) / FDA**

Anchor rod size		10x60	12x80	12x100	16x125	20x170	24x220	
Displacement-Factors for tension loading ¹⁾								
Uncracked concrete; Temperature range I, II								
Displacements	$\frac{\delta_{N0}}{\delta_{N\infty}}$	[mm/kN]	0,025	0,010	0,010	0,007	0,006	0,006
			0,050	0,020	0,020	0,014	0,012	0,012
Cracked concrete; Temperature range I, II								
Displacements	$\frac{\delta_{N0}}{\delta_{N\infty}}$	[mm/kN]	0,040	0,020	0,020	0,020	0,020	0,020
			0,060	0,030	0,030	0,030	0,030	0,030
Displacement-Factors for shear loading ²⁾								
Uncracked or cracked concrete; Temperature range I, II								
Displacements	$\frac{\delta_{V0}}{\delta_{V\infty}}$	[mm/kN]	0,025	0,010	0,010	0,007	0,006	0,006
			0,050	0,020	0,020	0,014	0,012	0,012

1) Calculation of effective displacement:

$$\delta_{N0} = \delta_{N0\text{-Factor}} \cdot N$$

$$\delta_{N\infty} = \delta_{N\infty\text{-Factor}} \cdot N$$

(N: acting tension loading)

2) Calculation of effective displacement:

$$\delta_{V0} = \delta_{V0\text{-Factor}} \cdot V$$

$$\delta_{V\infty} = \delta_{V\infty\text{-Factor}} \cdot V$$

(V: acting shear loading)

fischer Highbond-Anchor FHB / FHB dyn / FDA

Performance

Displacements for fischer anchor rods FHB-A / FHB-A N / FHB-A dyn (V) / FDA

Annex C4