

SUORITUSTASOILMOITUS

DoP 0282

fischer fischer Highbond-Anchor FHB II (injektioankkureiden kiinnitys betoniin)

FI

- Tuotetyypin yksilöllinen tunniste: **DoP 0282**
- Aiottu käyttötarkoitus (aiotut käyttötarkoitukset): **Jälkikäteen tehtäviin kiinnityksiin halkeilevassa tai halkeilemattomassa betonissa katso lisäksi, erityisesti liitteet B1 - B9.**
- Valmistaja: **fischerwerke GmbH & Co. KG, Klaus-Fischer-Str. 1, 72178 Waldachtal, Saksa**
- Valtuutettu edustaja: -
- Suoritustason pysyvyyden arvioinnissa ja varmentamisessa käytetty järjestelmä/käytetyt järjestelmät: 1
- Eurooppalainen arviointiasiakirja: **ETAG 001, Part 5, April 2013, käytetään EAD:nä**
Eurooppalainen tekninen arviointi: **ETA-05/0164; 2017-12-14**
Teknisestä arvioinnista vastaava laitos: **DIBt- Deutsches Institut für Bautechnik**
Ilmoitettu laitos/ilmoitetut laitokset: **2873 TU Darmstadt**
- Ilmoitettu suoritustaso/ilmoitetut suoritustasot:
Mekaaninen kestävyys ja vakaus (BWR 1)
Tyypillinen kestävyys kuormitukselle (staattinen ja lähes staattinen kuormitus):
Teräksen murtokuorma: Liitteet C1, C2
Ulosvetoarvon ja betonikuorman varmuuskerroin: Liitteet C1, C2

Betonimassan murtokuorma: Liitteet C1, C2
Reunaetäisyys halkeamien estämiseksi kuormituksessa: Liitteet C1, C2
Kestävyys: Liitteet C1-C4
Asennusmomentti: Liitteet B3, B4
Pienin reuna- ja keskinäis etäisyys: Liitteet B3, B4

Tyypillinen kestävyys leikkauskuormalle (staattinen ja näennäisstaattinen kuormitus):
Teräksen murtokuorma: Liitteet C3, C4
Taivutusvoiman murtokuorma: Liitteet C3, C4
Betonireunan murtokuorma: Liitteet C3, C4

Siirtymät lyhyt-kestoisessa ja pitkä-kestoisessa kuormituksessa:
Siirtymät lyhyt-kestoisessa ja pitkä-kestoisessa kuormituksessa: Liitteet C5, C6

Ominainen kestävyys ja siirtymät seismisille suoritusluokille C1 ja C2:
Kestävyys kuormitukselle, siirtymät, luokka C1: NPd
Kestävyys kuormitukselle, siirtymät, luokka C2: NPd
Leikkauskuorman kestävyys, siirtymät, luokka C1: NPd
Leikkauskuorman kestävyys, siirtymät, luokka C2: NPd
Rengasmaisen aukon kerroin: NPd

Hygienia, terveys ja ympäristö (BWR 3)
Vaarallisten aineiden pitoisuus, päästöt ja / tai vapautuminen: NPd
- Asianmukainen tekninen asiakirja ja/tai tekninen erityisasiakirja: -

($k_7=k_2$)

($k_8=k_3$)

Edellä yksilöidyn tuotteen suoritustaso on ilmoitettujen suoritustasojen joukon mukainen. Tämä suoritustasoilmoitus on asetuksen (EU) N:o 305/2011 mukaisesti annettu edellä ilmoitetun valmistajan yksinomaisella vastuulla.

Valmistajan puolesta allekirjoittanut:



Dr.-Ing. Oliver Geibig, Toimitusjohtaja Liiketoimintayksikkö & Suunnittelu
Tumlingen, 2021-01-19

Jürgen Grün, Toimitusjohtaja Kemia & Laatu

Tämä suoritustasoilmoitus on laadittu useilla kielillä. Jos tulkinnasta syntyy erimielisyyttä, englanninkielinen versio on aina katsottava ensisijaiseksi.

Lisäys sisältää vapaaehtoisesti ilmoitettua ja täydentävää englanninkielistä tietoa, joka ylittää (kielestä riippumatta määritellyt) lakisäätöiset vaatimukset.

Specific Part

1 Technical description of the product

The fischer Highbond-Anchor FHB II is a torque controlled bonded anchor consisting of a mortar cartridge with mortar fischer FIS HB or fischer mortar capsule FHB II–P(F) and an anchor rod FHB II - A L or FHB II - A S with hexagon nut and washer.

The glass capsule is set into a drilled hole in the concrete. The special formed anchor rod is driven into the glass capsule by machine with simultaneous hammering and turning. For the injection system the anchor rod is placed into a drilled hole filled with injection mortar. The load transfer is realised by mechanical interlock of several cones in the bonding mortar and then via a combination of bonding and friction forces in the anchorage ground (concrete).

The product description is given in Annex A.

2 Specification of the intended use in accordance with the applicable European Assessment Document

The performances given in Section 3 are only valid if the anchor is used in compliance with the specifications and conditions given in Annex B.

The verifications and assessment methods on which this European Technical Assessment is based lead to the assumption of a working life of the anchor of at least 50 years. The indications given on the working life cannot be interpreted as a guarantee given by the producer, but are to be regarded only as a means for choosing the right products in relation to the expected economically reasonable working life of the works.

3 Performance of the product and references to the methods used for its assessment

3.1 Mechanical resistance and stability (BWR 1)

Essential characteristic	Performance
Characteristic values under tension and shear load	See Annex C 1 to C 4
Displacements under tension and shear loads	See Annex C 5 and C 6

3.2 Safety in case of fire (BWR 2)

Essential characteristic	Performance
Reaction to fire	Anchorage satisfy requirements for Class A1
Resistance to fire	No performance assessed

3.3 Hygiene, health and the environment (BWR 3)

Regarding dangerous substances there may be requirements (e.g. transposed European legislation and national laws, regulations and administrative provisions) applicable to the products falling within the scope of this European Technical Assessment. In order to meet the provisions of Regulation (EU) No 305/2011, these requirements need also to be complied with, when and where they apply.

3.4 Safety in use (BWR 4)

The essential characteristics regarding Safety in use are included under the Basic Works Requirement Mechanical resistance and stability.

4 Assessment and verification of constancy of performance (AVCP) system applied, with reference to its legal base

In accordance with guideline for European technical approval ETAG 001, April 2013, used as European Assessment Document (EAD) according to Article 66 Paragraph 3 of Regulation (EU) No 305/2011, the applicable European legal act is: [96/582/EC].

The system to be applied is: 1

Installation conditions part 1

fischer Highbond - Anchor FHB II - A L

Pre-positioned installation

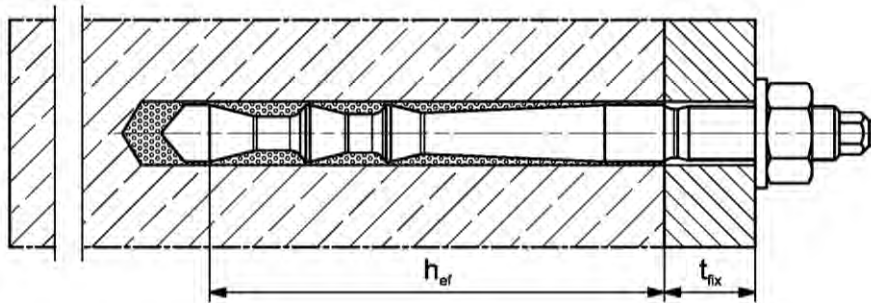

Push through installation not with mortar capsule (annular gap filled with mortar)

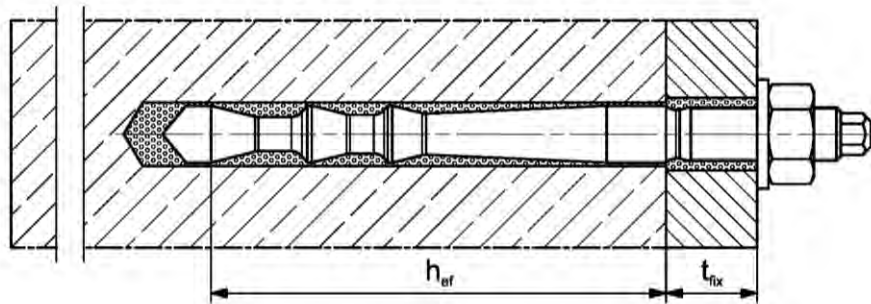

Pre-positioned or push through installation with subsequently pressed filling disk
(annular gap filled with mortar)

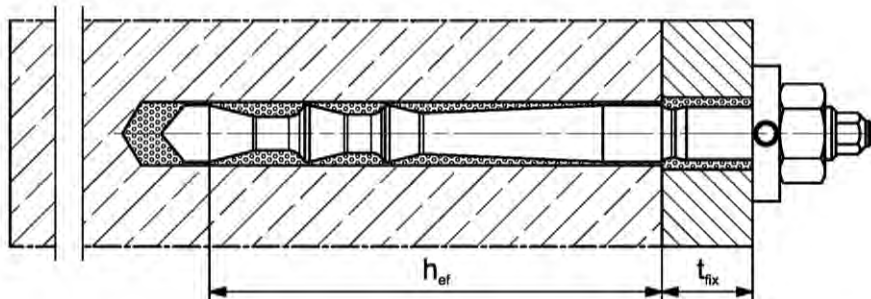

Pictures not to scale

h_{ef} = effective anchorage depth

t_{fix} = thickness of fixture

fischer Highbond-Anchor FHB II

Product description

Installation conditions part 1; FHB II - A L

Annex A 1

Appendix 3 / 22

Installation conditions part 2

fischer Highbond - Anchor FHB II - A S

Pre-positioned installation

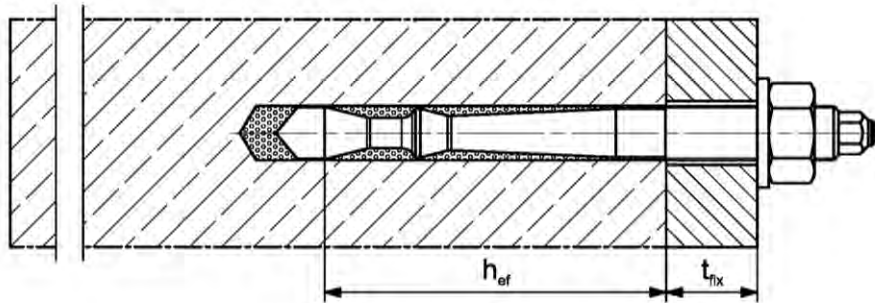

Push through installation

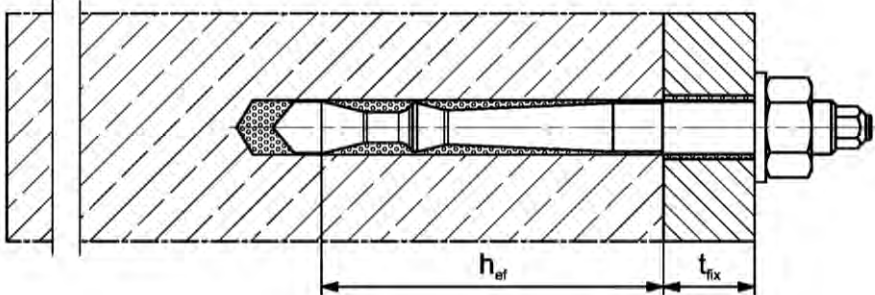

Pre-positioned or push through installation with subsequently pressed filling disk
(annular gap filled with mortar)

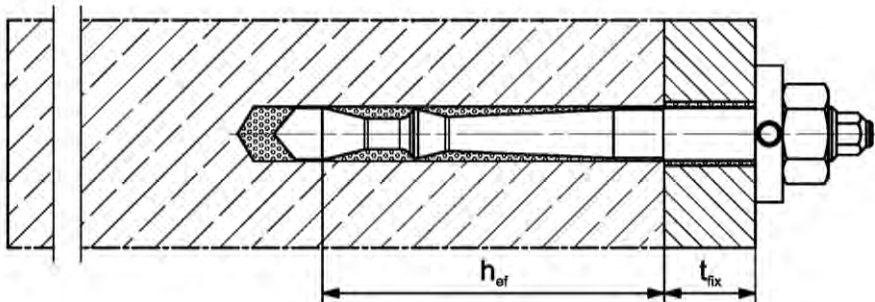

Pictures not to scale

h_{ef} = effective anchorage depth

t_{fix} = thickness of fixture

fischer Highbond-Anchor FHB II

Product description

Installation conditions part 2; FHB II - A S

Annex A 2

Appendix 4 / 22

Overview system components part 1

Mortar cartridge (shuttle cartridge) with sealing cap; Size: 360 ml, 950 ml

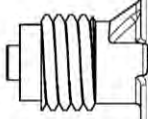
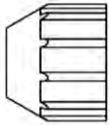

Imprint: fischer FIS HB, processing notes, shelf-life, piston travel scale (optional), curing times and processing times (depending on temperature), hazard code, size, volume



Mortar cartridge (coaxial cartridge) with sealing cap; Size: 150 ml, 300 ml

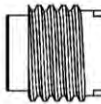
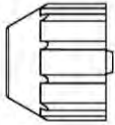

Imprint: fischer FIS HB, processing notes, shelf-life, piston travel scale (optional), curing times and processing times (depending on temperature), hazard code, size, volume



Mortar capsule



Static mixer MR or UMR

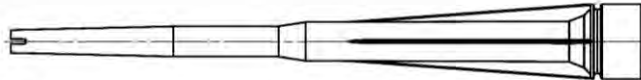

Extension tube for static mixer

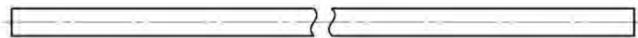

Cleaning brush BS



Blow-out pump ABG or ABP with cleaning nozzle

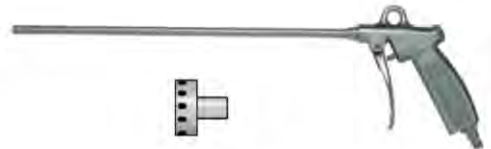

Pictures not to scale

fischer Highbond-Anchor FHB II

System description

Overview system components part 1;
cartridges / mortar capsule / accessories

Annex A 3

Appendix 5 / 22

Overview system components part 2

fischer Highbond - Anchor rod; pre-assembled condition

fischer Highbond - Anchor rod FHB II - A L

fischer Highbond - Anchor rod FHB II - A S

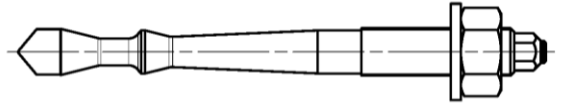
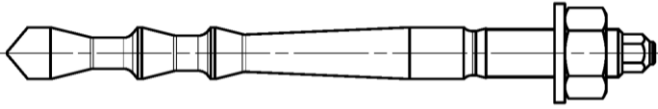

Anchor rod FHB II - A L

Size: M8, M10, M12, M16, M20



Anchor rod FHB II - A L

Size: M24

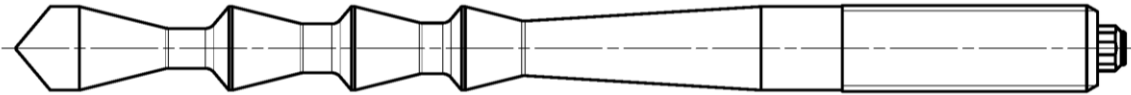

Anchor rod FHB II - A S

Size: M10, M12, M16, M20, M24

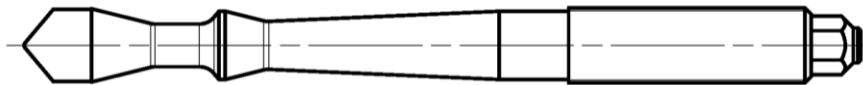

Washer

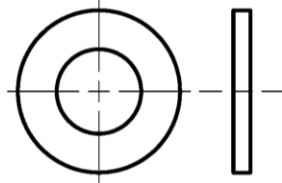

Hexagon nut

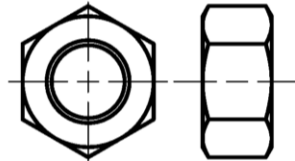

fischer filling disk FFD

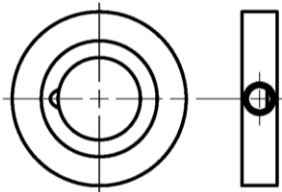

Pictures not to scale

fischer Highbond-Anchor FHB II

System description

Overview system components part 2;
Anchor rod / washer / hexagon nut / fischer filling disk FFD

Annex A 4

Appendix 6 / 22

Table A5.1: Materials

Part	Designation	Material		
1	Mortar cartridge	Mortar, hardener, filler		
2	Mortar capsule	Mortar, hardener, filler		
	Steel grade	Steel, zinc plated	Stainless steel A4	High corrosion resistant steel C
3	Fischer Highbond-Anchor rod FHB II - A L or FHB II - A S	Property class 8.8; EN ISO 898-1:2013 zinc plated $\geq 5 \mu\text{m}$, EN ISO 4042:1999 A2K $f_{uk} \leq 1000 \text{ N/mm}^2$ $A_5 > 12 \%$ fracture elongation	Property class 80 EN ISO 3506-1:2009 1.4401; 1.4404; 1.4578; 1.4571; 1.4439; 1.4362; 1.4062, 1.4662, 1.4462 EN 10088-1:2014 $f_{uk} \leq 1000 \text{ N/mm}^2$ $A_5 > 12 \%$ fracture elongation	Property class 80 EN ISO 3506-1:2009 1.4565; 1.4529 EN 10088-1:2014 $f_{uk} \leq 1000 \text{ N/mm}^2$ $A_5 > 12 \%$ fracture elongation
4	Washer ISO 7089:2000	zinc plated $\geq 5 \mu\text{m}$ EN ISO 4042:1999 A2K	1.4401; 1.4404; 1.4578; 1.4571; 1.4439; 1.4362; EN 10088-1:2014	1.4565;1.4529 EN 10088-1:2014
5	Hexagon nut	Property class 8; EN ISO 898-2:2012 zinc plated $\geq 5 \mu\text{m}$, ISO 4042:1999 A2K	Property class 70 EN ISO 3506-1:2009 1.4401; 1.4404; 1.4578; 1.4571; 1.4439; 1.4362; EN 10088-1:2014	Property class 70 EN ISO 3506-1:2009 1.4565; 1.4529 EN 10088-1:2014
6	fischer filling disk FFD similar to DIN 6319-G	zinc plated $\geq 5 \mu\text{m}$, EN ISO 4042:1999 A2K	1.4401; 1.4404; 1.4578; 1.4571; 1.4439; 1.4362; EN 10088-1:2014	1.4565;1.4529 EN 10088-1:2014



fischer Highbond-Anchor FHB II

System description
 Materials
Annex A 5

Appendix 7 / 22

Specifications of intended use (part 1)

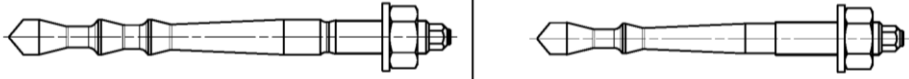
Table B1.1: Overview use and performance categories

Anchorage subject to		fischer injection mortar FIS HB or fischer mortar capsule FHB II-P or FHB II-PF with ...			
		FHB II – A L		FHB II – A S	
					
Hammer drilling with standard drill bit		all sizes			
Hammer drilling with hollow drill bit (Heller "Duster Expert" or Bosch "SpeedClean" or Hilti "TE-CD, TE-YD")		Nominal drill bit diameter (d_0) \geq 12 mm			
Static or quasi static load, in	uncracked concrete	all sizes	Tables: C1.1, C3.1, C5.1	all sizes	Tables: C2.1, C4.1, C6.1
	cracked concrete				
Use category	dry or wet concrete	all sizes			
	flooded hole	all sizes (only with mortar capsule allowed)			
Kind of installation	Pre-positioned anchor	all sizes			
	Push through anchor	all sizes (only with injection mortar FIS HB allowed)		all sizes	
Installation temperature	-5 C to +40 C				
In-service temperature	-40°C to +80°C (max. short term temperature +80 °C and max. long term temperature +50 °C)				

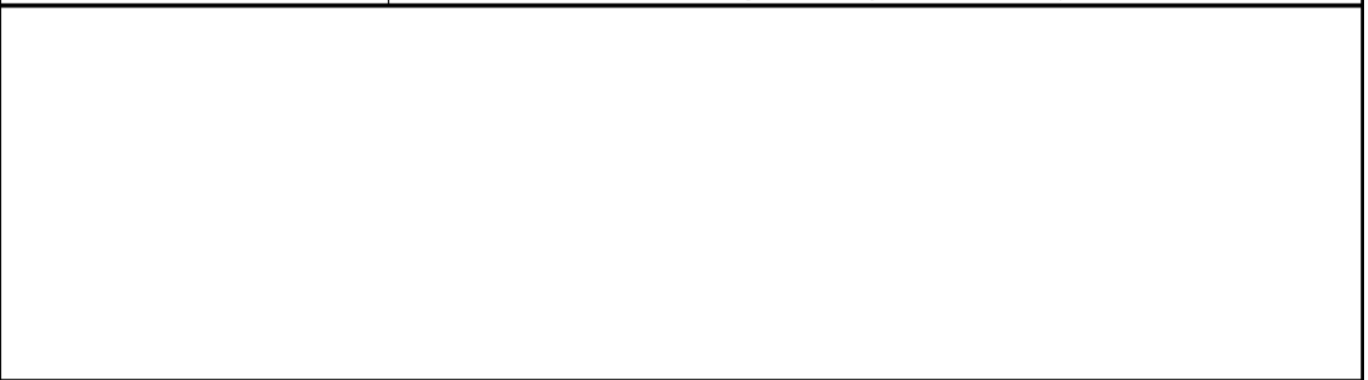

fischer Highbond-Anchor FHB II		Annex B 1 Appendix 8 / 22
Intended use Specifications (part 1)		

Specifications of intended use (part 2)

Base materials:

- Reinforced or unreinforced normal weight concrete Strength classes C20/25 to C50/60 according to EN 206-1:2000

Use conditions (Environmental conditions):

- Structures subject to dry internal conditions
(zinc coated steel, stainless steel or high corrosion resistant steel)
- Structures subject to external atmospheric exposure (including industrial and marine environment) and to permanently damp internal condition, if no particular aggressive conditions exist
(stainless steel or high corrosion resistant steel)
- Structures subject to external atmospheric exposure, to permanently damp internal conditions or in other particular aggressive conditions (high corrosion resistant steel)

Note: Particular aggressive conditions are e.g. permanent, alternating immersion in seawater or the splash zone of seawater, chloride atmosphere of indoor swimming pools or atmosphere with extreme chemical pollution (e.g. in desulphurization plants or road tunnels where de-icing materials are used)

Design:

- Anchorages have to be designed by a responsible engineer with experience of concrete anchor design
- Verifiable calculation notes and drawings are to be prepared taking account of the loads to be anchored. The position of the anchor is indicated on the design drawings (e.g. position of the anchor relative to reinforcement or to supports, etc.)
- Anchorages under static or quasi-static actions are designed in accordance with:
EOTA ETAG 001 Annex C, 08/2010 or CEN/TS 1992-4:2009

Installation:

- Anchor installation is to be carried out by appropriately qualified personnel and under the supervision of the person responsible for technical matters of the site
- In case of aborted hole: The hole shall be filled with mortar
- Observe the effective anchorage depth
- Overhead installation is allowed

fischer Highbond-Anchor FHB II

Intended Use
Specifications (part 2)

Annex B 2

Appendix 9 / 22

Table B3.1: Installation parameters for fischer Highbond - Anchor rods FHB II – A L

Anchor rod FHB II – A L	Thread	M8x		M10x		M12x		M16x			M20x	M24x
		60	95	100	120	125	145	160	210	210		
Corresponding mortar capsules FHB II-P or FHB II-PF	[-]	8x 60	10x 95	12x 100	12x 120	16x 125	16x 145	16x 160	20x 210	24x 210		
Cone diameter	d_k	9,4	10,7	12,5		16,8			23,0			
Width across flats	SW	13	17	19		24			30	36		
Nominal drill hole diameter	d_0	10	12	14		18			25			
Drill hole depth	h_0	75	110	115	135	140	160	175	235			
Effective anchorage depth	h_{ef}	60	95	100	120	125	145	160	210			
Minimum spacing and minimum edge distance	$s_{min} = c_{min}$	40		50		55	60	70	90			
Diameter of clearance hole in the fixture ¹⁾	pre-positioned anchorage $d_f \leq$	9	12	14		18			22	26		
	push through anchorage ²⁾ $d_f \leq$	11	14	16		20			26			
Min. thickness of concrete member	h_{min}	100	140		170		190	220	280			
Installation torque	T_{inst} [Nm]	15	20	40		60			100			
Thickness of fixture	$t_{fix} \leq$	1500										
fischer filling disk FFD ³⁾	$\geq d_a$ [mm]	-	26	30		38			46	54		
	t_s	-	6	6		7			8	10		

¹⁾ For larger clearance holes in the fixture see EOTA ETAG 001 Annex C, 08/2010 or CEN/TS 1992-4-:2009

²⁾ Only with mortar cartridge system FIS HB

³⁾ Using fischer filling disk FFD reduces t_{fix} (usable length of the anchor)

fischer Highbond – Anchor rod FHB II – A L

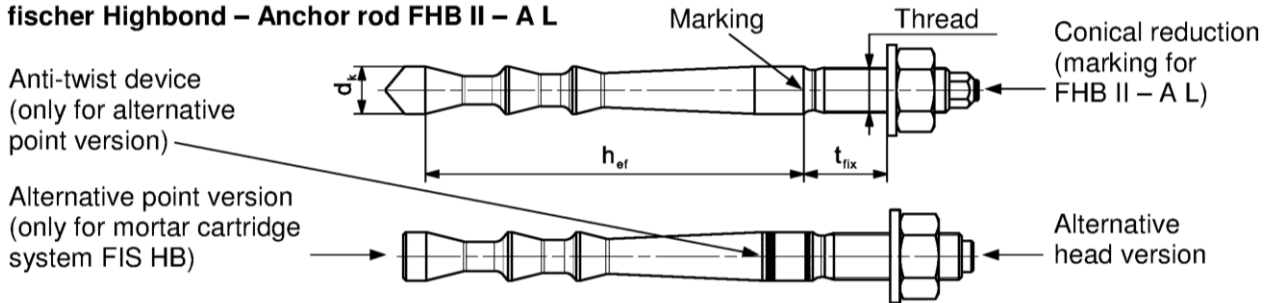

Marking: work symbol, size of anchor, setting depth. e.g.: M10x95
 For stainless steel additional **A4**. For high corrosion resistant steel additional **C**.
 For high corrosion resistant steel additional marking **C** also on the face side

Installation conditions:

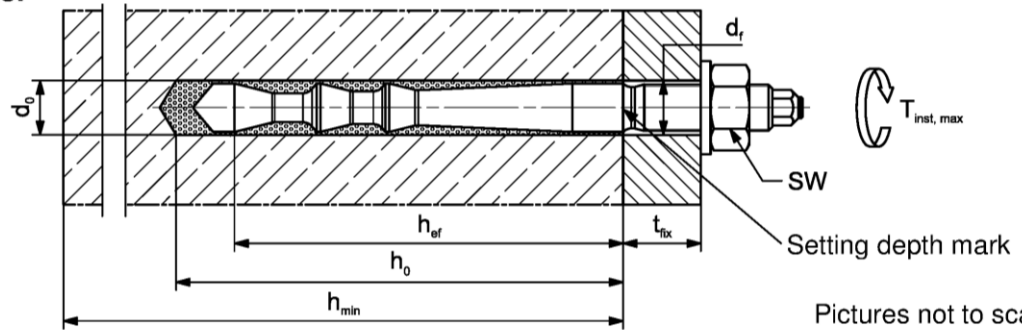

Pictures not to scale

fischer Highbond-Anchor FHB II

Intended Use

Installation parameters fischer Highbond-Anchor rod FHB II – A L

Annex B 3

Appendix 10 / 22

Table B4.1: Installation parameters for fischer Highbond – Anchor rods FHB II – A S

Anchor rod FHB II – A S	Thread	M10x		M12x	M16x	M20x	M24x	
		60	75	75	95	170	170	
Corresponding mortar capsules FHB II-P or FHB II-PF	[-]	10x60	10x75	12x75	16x95	20x170	24x170	
Cone diameter d_k	[mm]	9,4		11,3	14,5	23,0		
Width across flats SW		17		19	24	30	36	
Nominal drill hole diameter d_0		10		12	16	25		
Drill hole depth h_0		75	90	90	110	190		
Effective anchorage depth h_{ef}		60	75	75	95	170		
Minimum spacing and minimum edge distance $s_{min} = c_{min}$		40			50	80		
Diameter of clearance hole in the fixture ¹⁾		pre-positioned anchorage $d_f \leq$	12		14	18	22	26
		push through anchorage $d_f \leq$	12		14	18	26	
Min. thickness of concrete member h_{min}		100	120		150	240		
Installation torque T_{inst}	[Nm]	15		30	50	100		
Thickness of fixture $t_{fix} \leq$		1500						
fischer filling disk FFD ²⁾	$\geq d_a$	26		30	38	46	54	
	t_s	6		6	7	8	10	

¹⁾ For larger clearance holes in the fixture see EOTA ETAG 001 Annex C, 08/2010 or CEN/TS 1992-4-:2009

²⁾ Using fischer filling disk FFD reduces t_{fix} (usable length of the anchor)

fischer Highbond – Anchor rod FHB II – A S

Anti-twist device
(only for alternative point version)

Alternative point version
(only for mortar cartridge system FIS HB)

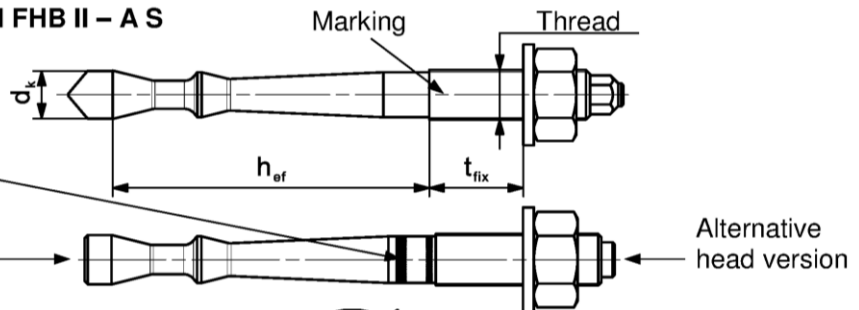

Marking: work symbol, size of anchor, setting depth. e.g.: M10x75
For stainless steel additional **A4**. For high corrosion resistant steel additional **C**.
For high corrosion resistant steel additional marking **C** also on the face side

Installation conditions:

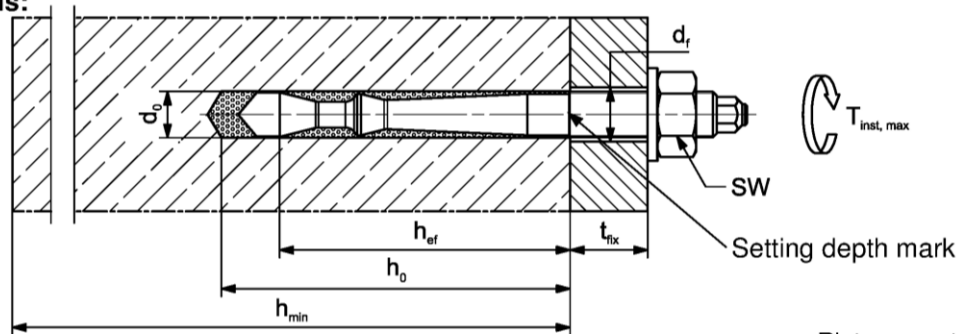

Pictures not to scale

fischer Highbond-Anchor FHB II

Intended Use

Installation parameters fischer Highbond-Anchor rod FHB II – A S

Annex B 4

Appendix 11 / 22

Table B5.1: Dimensions of mortar capsules FHB II-P and FHB II-PF

Mortar capsule		8x		10x		12x		16x			20x		24x		
		60	60	75	95	75	100	120	95	125	145	160	170	210	170
Length of capsule	L_p	85		90	115	95	120		150	155		185	210	185	210
Diameter of capsule	$\varnothing d_p$	9			11		12,5	14,5	17			21,5			

FHB II-P (standard)

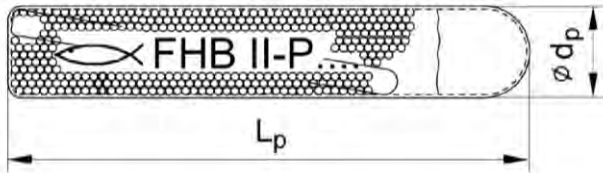

FHB II-PF (fast curing)

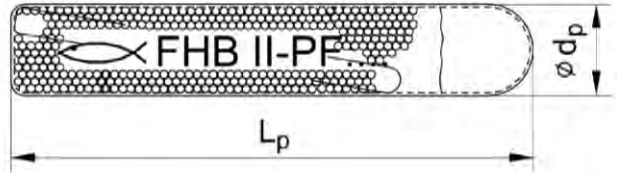

Imprint: work symbol, marking, anchor size and effective anchorage depth.

e.g.:  FHB II-P 12x100 or

 FHB II-PF 12x100

Table B5.2: Parameters of the cleaning brush BS (steel brush)
(only when using injection mortar)

The size of the steel brush refers to the nominal drill hole diameter

Drill hole diameter	d_o	[mm]	10	12	14	16	18	25
Brush diameter	d_b		11	13	16	20		27



Pictures not to scale

fischer Highbond-Anchor FHB II

Intende use

Dimensions of mortar capsules; parameters of the cleaning brush

Annex B 5

Appendix 12 / 22

Table B6.1: Maximum processing time of the mortar **FIS HB** and minimum curing time (During the curing time of the mortar the concrete temperature may not fall below the listed minimum temperature)

System temperature [°C]	Maximum processing time t_{work}	Minimum curing time ¹⁾ t_{cure}
-5 to -1	---	6 h
0 to +4	---	3 h
> +5 to +9	15 min	90 min
> +10 to +19	6 min	35 min
> +20 to +29	4 min	20 min
> +30 to +40	2 min	12 min

¹⁾ In wet concrete the curing times must be doubled

Table B6.2: Minimum curing time for mortar capsules **FHB II-P** and **FHB II-PF** (During the curing time of the mortar the concrete temperature may not fall below the listed minimum temperature)

Mortar capsule FHB II-P (standard)		Mortar capsule FHB II-PF (fast curing)	
System temperature [°C]	Minimum curing time ¹⁾ t_{cure}	System temperature [°C]	Minimum curing time ¹⁾ t_{cure}
-5 to ±0	4 h	-5 to ±0	8 min
> +1 to +10	45 min	> +1 to +10	6 min
> +11 to +20	20 min	> +11 to +20	4 min
> +20	10 min	> +20	2 min

¹⁾ In wet concrete or flooded holes the curing times must be doubled

fischer Highbond-Anchor FHB II

Intended use
Processing times and curing times

Annex B 6

Appendix 13 / 22

Installation instructions part 1; Installation with mortar capsule FHB II-P or FHB II-PF

Drilling the hole (hammer drilling with standard drill bit)

1		<p>Drill the hole with hammer drill. Drill hole diameter d_0 and drill hole depth h_0 see Tables B3.1, B4.1 Cleaning of the bore hole is not necessary</p>
---	-----------------------------------------------------------------------------------	---------------------------------------------------------------------------------------------------------------------------------------------------------------------------------------------------------------------------------------



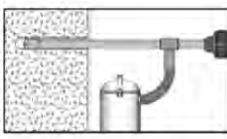

Go to step 3

Drilling and cleaning the hole (hammer drilling with hollow drill bit)

1		<p>Check a suitable hollow drill (see Table B1.1) for correct operation of the dust extraction</p>
2		<p>Use a suitable dust extraction system, e. g. Bosch GAS 35 M AFC or a comparable dust extraction system with equivalent performance data Drill the hole with hollow drill bit. The dust extraction system has to extract the drill dust nonstop during the drilling process and must be adjusted to maximum power. Diameter of drill hole d_0 and drill hole depth h_0 see Tables B3.1, B4.1</p>

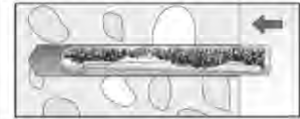
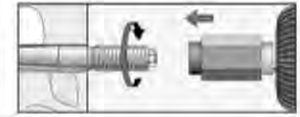
Go to step 3

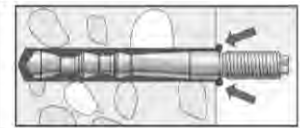

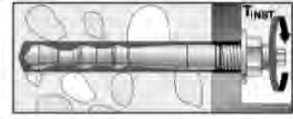
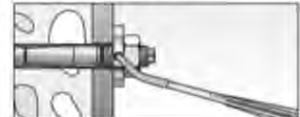



Installation Highbond-Anchor rod FHB II – A L and FHB II – A S

3		<p>Put the mortar capsule FHB II-P or FHB II-PF into the bore hole</p>
4	 	<p>Pre-positioned anchor: Only use Highbond-Anchor rods FHB II - A L or FHB II - A S with roof-shaped point. Drive in the Anchor rod using a hammer drill or impact drill. When reaching the setting depth mark stop the drill immediately.</p> <p>Push through anchor: Only use Highbond-Anchor rods FHB II - A S with roof-shaped point. Drive in the anchor rod using a hammer drill or impact drill. When reaching the setting depth mark stop the drill immediately.</p>
5		<p>After inserting the anchor, excess mortar must be emerged around the anchor.</p>
5a		<p>For overhead installations support the anchor rod with wedges. (e.g. fischer centering wedges)</p>
6		<p>Wait for the specified curing time t_{cure} see Table B.2</p>
7		<p>Mounting the fixture T_{inst} see Tables B3.1, B4.1</p>
Option		<p>After the minimum curing time is reached, the gap between anchor and fixture (annular clearance) may be filled with mortar via the fischer filling disc FFD. compressive strength $\geq 50 \text{ N/mm}^2$ (e.g. FIS HB). ATTENTION: Using fischer filling disc FFD reduces t_{fix} (usable length of the anchor)</p>

fischer Highbond-Anchor FHB II		Annex B 7 Appendix 14 / 22
Intended use Installation instructions part 1; Installation with mortar capsule		

Installation instructions part 2; Installation with injection mortar FIS HB

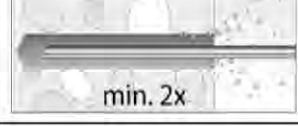
Drilling and cleaning the hole (hammer drilling with standard drill bit)

1		<p>Drill the hole with hammer drill. Drill hole diameter d_0 and drill hole depth h_0 see Tables B3.1, B4.1</p>
2	 <p>min. 2x</p>	<p>Blow out the drill hole twice. If necessary, remove standing water out of the bore hole</p>
3		<p>For drill hole diameter $d_0 < 25$ mm with hand-blowout or oil-free compressed air</p>
3	 <p>min. 2x</p>	<p>Brush the bore hole twice. Corresponding brushes see Table B5.2</p> 
4	 <p>min. 2x</p>	<p>Blow out the drill hole twice</p>
4		<p>For drill hole diameter $d_0 < 25$ mm with hand-blowout or oil-free compressed air</p>
		<p>For drill hole diameter $d_0 = 25$ mm with oil-free compressed air ($p \geq 6$ bar) Use a cleaning nozzle</p> 

Go to step 5

Drilling and cleaning the hole (hammer drilling with hollow drill bit)

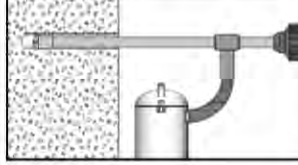
1		<p>Check a suitable hollow drill (see Table B1.1) for correct operation of the dust extraction</p>
2		<p>Use a suitable dust extraction system, e. g. Bosch GAS 35 M AFC or a comparable dust extraction system with equivalent performance data. Drill the hole with hollow drill bit. The dust extraction system has to extract the drill dust nonstop during the drilling process and must be adjusted to maximum power. Diameter of drill hole d_0 and drill hole depth h_0 see Tables B3.1, B4.1</p>

Go to step 5

fischer Highbond-Anchor FHB II

Intended use



Installation instructions part 2; Installation with injection mortar

Annex B 8

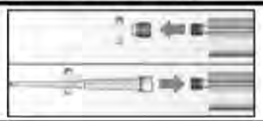

Appendix 15 / 22

Installation instruction part 3; Installation with injection mortar FIS HB

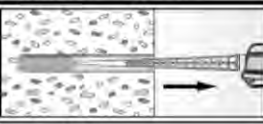

Preparing the cartridge

5		<p>Remove the sealing cap Screw on the static mixer (the spiral in the static mixer must be clearly visible)</p>
6		<p>Place the cartridge into the dispenser</p>
7		<p>Extrude approximately 10 cm of material until the resin is evenly grey in colour. Do not use mortar that is not uniformly grey</p>

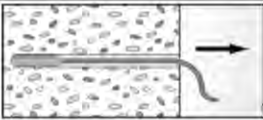
Injection of the mortar

8		<p>Fill approximately 2/3 of the drill hole with mortar. Exact quantity of mortar (travel scale on the cartridge) see instruction sheet. Fill the drill hole with mortar, always begin from the bottom of the hole to avoid bubbles</p>
		<p>Push-through installation: By using Highbond-Anchor rods FHB II - AL the drill hole in the fixture must be also filled with mortar. By using Highbond-Anchor rods FHB II - AS is this not necessary.</p>
		<p>For drill hole depth ≥ 170 mm use an extension tube</p>

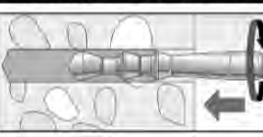
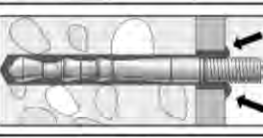
Installation Highbond-Anchor rod FHB II – A L and FHB II – A S

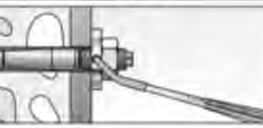
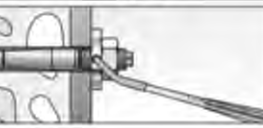
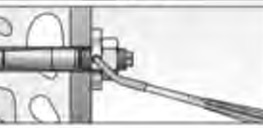
9		<p>Only use clean and oil-free anchor rods. Push the anchor rod down to the bottom of the hole, turning it slightly while doing so.</p>	
10		<p>After inserting the anchor rod FHB II - AL, surplus mortar must be escaped from the fixture. After inserting the anchor rod FHB II - AS, surplus mortar must be escaped from the bore hole or must be visible in the fixture.</p>	
		<p>For overhead installations support the anchor rod with wedges. (e.g. fischer centering wedges)</p> 	
11		<p>Wait for the specified curing time t_{cure} see Table B6.1</p>	<p>12  Mounting the fixture T_{inst} see Tables B3.1, B4.1</p>
Option		<p>After the minimum curing time is reached, the gap between anchor and fixture (annular clearance) may be filled with mortar via the fischer filling disc FFD. compressive strength ≥ 50 N/mm² (e.g. FIS HB). ATTENTION: Using fischer filling disc FFD reduces t_{fix} (usable length of the anchor)</p>	

fischer Highbond-Anchor FHB II

Intended use

Installation instructions part 3; Installation with injection mortar

Annex B 9

Appendix 16 / 22

Table C1.1: Characteristic values under static and quasi-static **tension load** for **fischer Highbond-Anchor FHB II – A L**

Anchor rod FHB II – A L			M8x 60	M10x 95	M12x 100 120		M16x 125 145 160			M20x 210	M24x 210	
Bearing capacity under tensile load, steel failure												
Characteristic resistance $N_{Rk,s}$	Steel, zinc plated	[kN]	25,1	34,4	49,8		96,6			137,6		
	Stainless steel A4		25,1	34,4	49,8		96,6			137,6		
	High corrosion resistant steel C		25,1	34,4	49,8		96,6			137,6		
Partial safety factors¹⁾												
Partial safety factor $\gamma_{Ms,N}$	Steel, zinc plated	[-]					1,5 ¹⁾					
	Stainless steel A4						1,5 ¹⁾					
	High corrosion resistant steel C						1,5 ¹⁾					
Pullout failure in cracked concrete C20/25												
Characteristic resistance	$N_{Rk,p}$	[kN]	--- ³⁾									
Pullout and splitting failure in uncracked concrete C20/25												
Characteristic resistance	$N_{Rk,p}$	[kN]	--- ³⁾									
Edge distance	$C_{cr,sp}$	[mm]	300	476	380	600	375	500	580	630		
Spacing	$S_{cr,sp}$		150	238	190	300	188	250	290	315		
Pullout and splitting failure in uncracked concrete C20/25												
Characteristic resistance	$N_{Rk,p}$ ²⁾	[kN]	20	35	40	50	--- ³⁾	75	95	--- ³⁾		
Edge distance	$C_{cr,sp}$	[mm]	1,5 h_{ef}									
Spacing	$S_{cr,sp}$		3,0 h_{ef}									
Factors for the compressive strength of concrete > C20/25												
Increasing factor for $N_{Rk,p}$	C25/30	Ψ_c	[-]	1,10								
	C30/37			1,22								
	C35/45			1,34								
	C40/50			1,41								
	C45/55			1,48								
	C50/60			1,55								
Factors acc. to CEN/TS 1992-4:2009 Section 6.2.2.3												
Uncracked concrete	K_{ucr}	[-]	10,1									
Cracked concrete	K_{cr}		7,2									
Concrete cone failure												
Effective anchorage depth	h_{ef}	[mm]	60	95	100	120	125	145	160	210		
Partial safety factor ^{1) 5)}	γ_{Mc}	[-]	1,5 ⁴⁾	1,5								

¹⁾ In absence of other national regulations

²⁾ Proof of splitting failure acc. ETAG 001, Annex C, (Section 5.3). Instead of $N_{Rk,c}^0$ use $N_{Rk,p}$.

³⁾ Not decisive (proof of splitting failure acc. ETAG 001, Annex C)

⁴⁾ With mortar capsule: $\gamma_{Mc} = 1,8$

⁵⁾ $\gamma_2 = 1,0$ is included

fischer Highbond-Anchor FHB II

Performances

Characteristic values under static and quasi-static tension load for fischer Highbond-Anchor FHB II – A L

Annex C 1

Appendix 17 / 22

Table C2.1: Characteristic values under static and quasi-static **tension load** for **fischer Highbond-Anchor FHB II – A S**

Anchor rod FHB II – A S		M10x		M12x	M16x	M20x	M24x
		60	75	75	95	170	170
Bearing capacity under tensile load, steel failure							
Characteristic resistance $N_{Rk,s}$	Steel, zinc plated	[kN]	25,1	34,4	61,6	128,5	
	Stainless steel A4		25,1	34,4	61,6	128,5	
	High corrosion resistant steel C						
Partial safety factors¹⁾							
Partial safety factor $\gamma_{Ms,N}$	Steel, zinc plated	[-]	1,5 ¹⁾				
	Stainless steel A4		1,5 ¹⁾				
	High corrosion resistant steel C		1,5 ¹⁾				
Pullout failure in cracked concrete C20/25							
Characteristic resistance	$N_{Rk,D}$	[kN]	--- ³⁾				
Pullout and splitting failure in uncracked concrete C20/25							
Characteristic resistance	$N_{Rk,D}$	[kN]	--- ³⁾				
Edge distance	$c_{cr,sp}$	[mm]	300		340	510	
Spacing	$s_{cr,sp}$		150		170	255	
Pullout and splitting failure in uncracked concrete C20/25							
Characteristic resistance	$N_{Rk,p}$ ²⁾	[kN]	20	25	40	--- ³⁾	
Edge distance	$c_{cr,sp}$	[mm]	1,5 h_{ef}				
Spacing	$s_{cr,sp}$		3,0 h_{ef}				
Factors for the compressive strength of concrete > C20/25							
Increasing factor for $N_{Rk,p}$	C25/30	Ψ_c	[-]	1,10			
	C30/37			1,22			
	C35/45			1,34			
	C40/50			1,41			
	C45/55			1,48			
	C50/60			1,55			
Factors acc. to CEN/TS 1992-4:2009 Section 6.2.2.3							
Uncracked concrete	k_{ucr}	[-]	10,1				
Cracked concrete	k_{cr}		7,2				
Concrete cone failure							
Effective anchorage depth	h_{ef}	[mm]	60	75	95	170	
Partial safety factor ^{1) 5)}	γ_{Mc}	[-]	1,5 ⁴⁾	1,5			

¹⁾ In absence of other national regulations

²⁾ Proof of splitting failure acc. ETAG 001, Annex C, (Section 5.3). Instead of $N_{Rk,c}^0$ use $N_{Rk,p}$.

³⁾ Not decisive (proof of splitting failure acc. ETAG 001, Annex C)

⁴⁾ With mortar capsule: $\gamma_{Mc} = 1,8$

⁵⁾ $\gamma_2 = 1,0$ is included

fischer Highbond-Anchor FHB II

Performances

Characteristic values under static and quasi-static tension load for fischer Highbond-Anchor FHB II – A S

Annex C 2

Appendix 18 / 22

Table C3.1: Characteristic values under static and quasi-static **shear load** for **fischer Highbond-Anchor FHB II – A L**

Anchor rod FHB II – A L		M8x	M10x	M12x		M16x			M20x	M24x	
		60	95	100	120	125	145	160	210	210	
Bearing capacity under shear load, steel failure											
without lever arm											
Characteristic resistance	Steel, zinc plated	$V_{Rk,s}$	[kN]	13,7	20,8	30,3		56,3		87,9	126,9
	Stainless steel A4 and High corrosion resistant steel C			15,2	23,2	33,7		62,7		97,9	141
with lever arm											
Characteristic bending moment	Steel, zinc plated	$M^0_{Rk,s}$	[Nm]	31	62	105		266		519	896
	Stainless steel A4 and High corrosion resistant steel C			31	62	105		266		519	896
Partial safety factors											
Partial safety factors ¹⁾	$\gamma_{Ms,V}$	[-]	1,25								
Ductility factor acc. to CEN/TS 1992-4-5:2009 Section 6.3.2.1	k_2	[-]	1,0								
Concrete pry-out failure											
Factor k acc. TR029 Section 5.2.3.3 or k_3 acc. CEN/TS 1992-4-5:2009 Section 6.3.3	$k_{(3)}$	[-]	2,0								
Partial safety factors ¹⁾	γ_{Mcd}		1,5								
Concrete edge failure											
Effective length of anchor	l_f	[mm]	60	95	100	112	125	144		200	
Calculation diameter	d		10	12	14		18		25		
Partial safety factor ¹⁾	γ_{Mc}	[-]	1,5								

¹⁾ In absence of other national regulations

fischer Highbond-Anchor FHB II

Performances

Characteristic values under static and quasi-static shear load for fischer Highbond-Anchor FHB II – A L

Annex C 3

Appendix 19 / 22

Table C4.1: Characteristic values under static and quasi-static **shear load** for **fischer Highbond-Anchor FHB II – A S**

Anchor rod FHB II – A S		M10x		M12x	M16x	M20x	M24x	
		60	75	75	95	170	170	
Bearing capacity under shear load, steel failure								
Without lever arm								
Characteristic resistance	Steel, zinc plated	$V_{Rk,s}$	[kN]	19,7	27,3	50,8	80,3	114,2
	Stainless steel A4			24,1	33,7	62,7	97,9	124,5
	High corrosion resistant steel C			24,1	33,7	62,7	97,9	141
With lever arm								
Characteristic bending moment	Steel, zinc plated	$M^0_{Rk,s}$	[Nm]	62	105	266	519	896
	Stainless steel A4 and High corrosion resistant steel C			62	105	266	519	896
Partial safety factors								
Partial safety factor ¹⁾	$\gamma_{Ms,V}$	[-]	1,25					
Ductility factor acc. to CEN/TS 1992-4-5:2009 Section 6.3.2.1	k_2	[-]	1,0					
Concrete pryout failure								
Factor k acc. TR029 Section 5.2.3.3 or k_3 acc. CEN/TS 1992-4-5:2009 Section 6.3.3	$k_{(3)}$	[-]	2,0					
Partial safety factor ¹⁾	γ_{Mcp}	[-]	1,5					
Concrete edge failure								
Effective length of anchor	l_f	[mm]	60	75	95	170		
Calculation diameter	d		10	12	16	25		
Partial safety factor ¹⁾	γ_{Mc}	[-]	1,5					
¹⁾ In absence of other national regulations								
fischer Highbond-Anchor FHB II						Annex C 4 Appendix 20 / 22		
Performances Characteristic values under static and quasi-static shear load for fischer Highbond-Anchor FHB II – A S								

Table C5.1: Displacement for fischer Highbond-Anchor FHB II – A L

Anchor rod FHB II – A L	M8x	M10x	M12x		M16x		M20x	M24x	
	60	95	100	120	125	145	160	210	210
Displacement under tension load									
Cracked concrete									
Tension load [kN]	6,6	15,9	17,1	22,5	24,0	30,0	34,7	52,2	52,2
δ_{N0} [mm]	0,8				0,6				
$\delta_{N\infty}$	1,7								
Uncracked concrete									
Tension load [kN]	9,3	22,3	24,0	31,6	33,6	42,0	48,7	73,2	73,2
δ_{N0} [mm]	0,2	0,4					0,6		
$\delta_{N\infty}$	1,7								
Displacement under shear load									
Uncracked or cracked concrete									
Steel zinc plated									
Shear load [kN]	7,8	11,9	17,3		32,2		50,2	72,5	
δ_{V0} [mm]	1,2		1,3			3,5			
$\delta_{V\infty}$	1,8		2,0			5,3			
Stainless steel A4									
Shear load [kN]	8,7	13,3	19,3		35,8		55,9	80,6	
δ_{V0} [mm]	1,0		1,1		2,2		3,5		
$\delta_{V\infty}$	1,5		1,7		3,3		5,3		
High corrosion resistant steel C									
Shear load [kN]	8,7	13,3	19,3		35,8		55,9	80,6	
δ_{V0} [mm]	1,2		1,3		2,4		3,7	5,0	
$\delta_{V\infty}$	1,8		2,0		3,6		5,6	7,5	

fischer Highbond-Anchor FHB II

Performances

Displacement for fischer Highbond-Anchor FHB II – A L

Annex C 5

Appendix 21 / 22

Table C6.1: Displacement for **fischer Highbond-Anchor FHB II – A S**

Anchor rod FHB II – A S	M10x		M12x	M16x	M20x	M24x
	60	75	75	95	170	170
Displacement under tension load						
Cracked concrete						
Tension load [kN]	6,6	11,1	15,9	38,0		
δ_{N0} [mm]	0,8	0,3	0,4	0,6		
$\delta_{N\infty}$	1,7					
Uncracked concrete						
Tension load [kN]	9,3	15,6	22,3	53,3		
δ_{N0} [mm]	0,2			0,5		
$\delta_{N\infty}$	1,7					
Displacement under shear load						
Cracked or uncracked concrete						
Steel zinc plated						
Shear load [kN]	11,3	12,7	29,0	45,9	65,3	
δ_{V0} [mm]	1,2	1,5	2,8			
$\delta_{V\infty}$	1,8	2,3	4,2			
Stainless steel A4						
Shear load [kN]	13,8	19,3	35,8	55,9	71,1	
δ_{V0} [mm]	1,0	1,1	2,2	3,5		
$\delta_{V\infty}$	1,5	1,7	3,3	5,3		
High corrosion resistant steel C						
Shear load [kN]	13,8	19,3	35,8	55,9	80,6	
δ_{V0} [mm]	1,2	1,3	2,4	3,7	5,0	
$\delta_{V\infty}$	1,8	2,0	3,6	5,6	7,5	
fischer Highbond-Anchor FHB II					Annex C 6 Appendix 22 / 22	
Performances Displacement for fischer Highbond-Anchor FHB II – A S						