



DECLARACIÓN DE PRESTACIONES

DoP 0263

para fischer Heavy-duty anchor TA M, TA M S, TA M T (anclaje mecánico para uso en hormigón)

ES

- Código de identificación única del producto tipo: DoP 0263
- Usos previstos: Fijación a posteriori en hormigón no fisurado, véase el apéndice, especialmente los anexos B1 - B3.
- Fabricante: fischerwerke GmbH & Co. KG, Klaus-Fischer-Str. 1, 72178 Waldachtal, Alemania
- Representante autorizado: -
- Sistemas de evaluación y verificación de la constancia de las prestaciones (EVCP): 1
- Documento de evaluación europeo: EAD 330232-00-0601
Evaluación técnica europea: ETA-04/0003; 2018-06-12
Organismo de evaluación técnica: DIBt- Deutsches Institut für Bautechnik
Organismos notificados: 2873 TU Darmstadt

7. Prestaciones declaradas:

Resistencia mecánica y estabilidad (BWR 1)

Resistencia característica a tracción (carga estática y cuasi-estática):

Resistencia de rotura del acero: Anexo C1 $E_s = 210\,000\text{ MPa}$
Résistance à la rupture par extraction glissement: Anexo C1
Resistencia de rotura por cono de hormigón: Anexo C1
Robustez: Anexo C1
Distancia mínima entre el borde y el centro: Anexo B2
Distancia al borde para evitar la rotura del acero sometido a carga: Anexo C1 $N_{Rk,sp}^0 = \text{NPD}$

Resistencia característica a cortante (carga estática y cuasi-estática):

Resistencia de rotura del acero (esfuerzo cortante): Anexo C2
Resistencia falla por arrancamiento lateral: Anexo C2
Resistencia de rotura del hormigón al borde: Anexo C2
Desplazamiento por carga estática y cuasi-estática: Anexo C2
Durabilidad: Anexos A3, A4, B1

Resistencia y desplazamientos característicos para las categorías sísmicas C1 y C2:

Resistencia de rotura del acero: NPD
Résistance à la rupture par extraction glissement:
Alargamiento de rotura: NPD
Factor espacio anular: NPD
Desplazamientos: NPD

Seguridad en caso de incendio (BWR 2)

Reacción al fuego: Clase (A1)

Resistencia al fuego:

Resistencia al fuego, rotura del acero (carga de tracción): NPD
Resistencia al fuego, a la extracción (carga de tracción): NPD
Resistencia al fuego, rotura del acero (esfuerzo cortante): NPD

8. Documentación técnica adecuada o documentación técnica específica:

Las prestaciones del producto identificado anteriormente son conformes con el conjunto de prestaciones declaradas. La presente declaración de prestaciones se emite, de conformidad con el Reglamento (UE) no 305/2011, bajo la sola responsabilidad del fabricante arriba identificado.

Firmado por y en nombre del fabricante por:

Dr.-Ing. Oliver Geibig, Director General Unidades de Negocio e Ingeniería
Tümlingen, 2021-01-12

Jürgen Grün, Director General de Química y Calidad

Esta DdR se ha preparado en distintos idiomas. En caso de que haya alguna controversia sobre la interpretación prevalecerá siempre la versión inglesa.

El Apéndice incluye información voluntaria y complementaria en idioma inglés que excede los requisitos legales (de idioma neutral).

Specific Part

1 Technical description of the product

The fischer Heavy-duty anchor TA M, TA M S and TA M T in the range of M6, M8, M10 and M12 is an anchor made of galvanised steel which is placed into a drilled hole and anchored by torque-controlled expansion with the hexagon head bolt.

The product description is given in Annex A.

2 Specification of the intended use in accordance with the applicable European Assessment Document

The performances given in Section 3 are only valid if the concrete screw is used in compliance with the specifications and conditions given in Annex B.

The verifications and assessment methods on which this European Technical Assessment is based lead the assumption of working life of the concrete screw of at least 50 years. The indications given on the working life cannot be interpreted as a guarantee given by the producer, but are to be regarded only as a means for choosing the right products in relation to the expected economically reasonable working life of the works.

3 Performance of the product and references to the methods used for its assessment

3.1 Mechanical resistance and stability (BWR 1)

Essential characteristic	Performance
Characteristic resistance to tension load (static and quasi-static loading)	see Annex C 1
Characteristic resistance to shear load (static and quasi-static loading)	see Annex C 2
Displacements (static and quasi-static loading)	see Annex C 2
Characteristic resistance and displacements for seismic performance categories C1 and C2	No performance assessed

3.2 Safety in case of fire (BWR 2)

Essential characteristic	Performance
Reaction to fire	Class A1
Resistance to fire	No performance assessed

4 Assessment and verification of constancy of performance (AVCP) system applied, with reference to its legal base

In accordance with European Assessment Documents EAD No. 330232-00-0601 the applicable European legal act is: [96/582/EC].

The system to be applied is: 1

Pre-positioned installation:

TA M

The hexagon head screw and the washer according to table A4.1 and A4.2 must be provided by the user

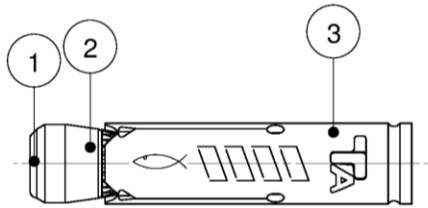

TA M S

The hexagon head screw is provided by the manufacturer (fischer) together with the anchor

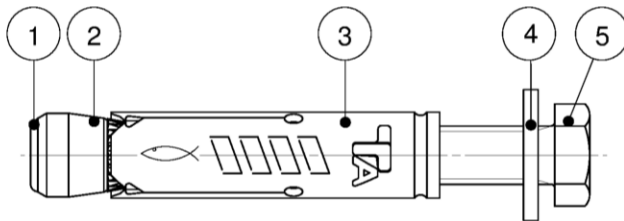

In-place installation:

TA M T

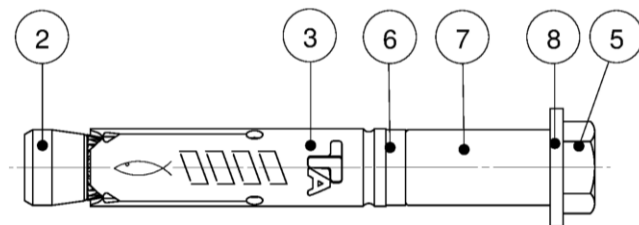

- | | |
|--------------------------|----------------------|
| 1 Plastic cap (optional) | 5 Hexagon head screw |
| 2 Cone-nut | 6 Distance ring |
| 3 Expansion sleeve | 7 Spacing sleeve |
| 4 Washer (TA M / TA M S) | 8 Washer (TA M T) |

(Fig. not to scale)

fischer Heavy-duty anchor TA M, TA M S, TA M T

Product description
Anchor types

Annex A 1

Appendix 2 / 10

TA M / TA M S

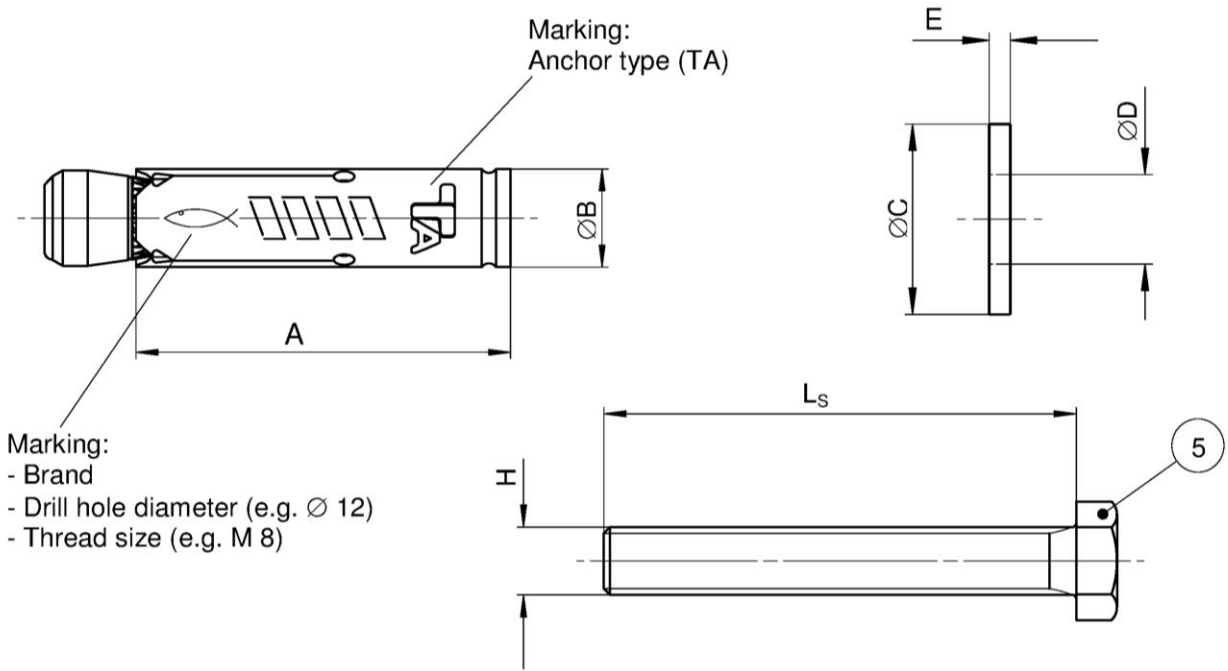

TA M T

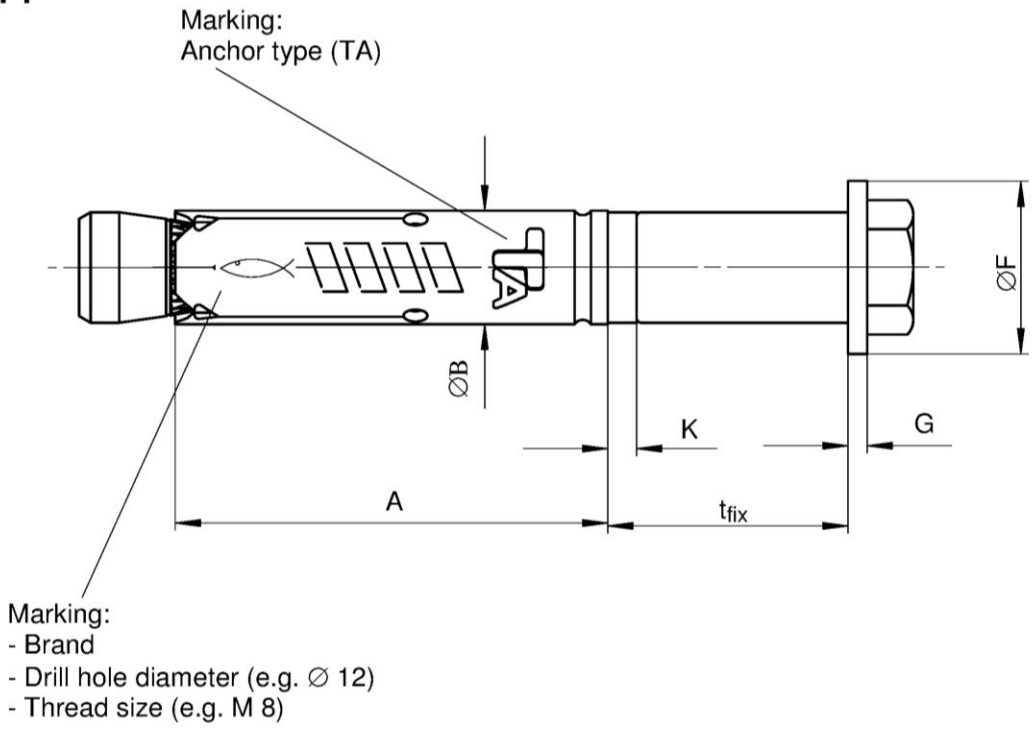

(Fig. not to scale)

fischer Heavy-duty anchor TA M, TA M S, TA M T

Product description
Anchor components

Annex A 2

Appendix 3 / 10

Table A3.1: Anchor dimensions [mm]

Part	Designation	Type of anchor		M6	M8	M10	M12
3	Expansion sleeve	TA M / TA M S / TA M T	A	40,0	45,0	55,0	70,0
			∅ B	9,6	11,8	14,5	17,5
4	Washer ¹⁾	TA M S	∅ C ≥	11,0	15,0	19,0	23,0
			E ≥	1,4	1,4	1,8	2,3
8	Washer	TA M T	∅ F ≥	17,0	21,0	25,0	30,0
			G ≥	1,4	1,8	2,3	2,7
5	Hexagon head screw ²⁾	TA M S / TA M T	L _s ≥	t _{fix} + 50	t _{fix} + 55	t _{fix} + 70	t _{fix} + 85
			H	M6	M8	M10	M12
6	Distance ring	TA M T	K =	3,0	3,0	3,0	3,0

¹⁾ For specification - summary of washer for TA M see table A4.2

²⁾ For specification - summary of hexagon head screw for TA M see table A4.1

Table A3.2: Materials

Part	Designation	Type of anchor	Materials	Treatment
1	Plastic cap ¹⁾	TA M / TA M S	Polyamide	-
2	Cone-nut	TA M / TA M S / TA M T	Steel, EN 10277:2008	Zinc plated according to EN ISO 4042:2017, min 5 µm, additional functional coating
3	Expansion sleeve	TA M / TA M S / TA M T	Cold-rolled steel EN 10139:2016	Zinc plated according to EN ISO 4042:2017, min 5 µm
4	Washer ²⁾	TA M S	Steel, min 140 HV	
8	Washer	TA M T		
5	Hexagon head screw ³⁾	TA M S / TA M T	Steel, property class 8.8	
6	Distance ring	TA M T	Polyethylen	-
7	Distance sleeve	TA M T	Cold-rolled steel EN 10139:2016/ Steel EN 10 277:2008	Zinc plated according to EN ISO 4042:2017, min 5 µm

¹⁾ Optional

²⁾ For specification - summary of washer for TA M see table A4.2

³⁾ For specification - summary of hexagon head screw for TA M see table A4.1

fischer Heavy-duty anchor TA M, TA M S, TA M T

Product description
Anchor dimensions
Materials

Annex A 3

Appendix 4 / 10

Table A4.1: Selection criteria for the hexagon head screw (TA M)

Description			TA M6	TA M8	TA M10	TA M12
Length of hexagon head screw	L_S	[mm]	$\geq t_{fix} + 50$	$\geq t_{fix} + 55$	$\geq t_{fix} + 70$	$\geq t_{fix} + 85$
Thread size	H	[-]	M6	M8	M10	M12
Standardisation			ISO 4014:2017 / ISO 4017:2014 or DIN 931:1987 / DIN 933:1987			
Material			Steel, property class 8.8			
Treatment			Zinc plated according to EN ISO 4042:2017, min 5 μ m			

Table A4.2: Selection criteria for the washer (TA M)

Description			TA M6	TA M8	TA M10	TA M12
Hole diameter	D	min	6,0	8,0	10,0	12,0
		max	6,6	8,6	10,8	13,3
External diameter	C	[mm]	$\geq 11,0$	$\geq 15,0$	$\geq 19,0$	$\geq 23,0$
Thickness	E	min	1,4	1,4	1,8	2,3
		max	3,0	3,0	4,0	5,0
Material			Steel, hardness class min 140 HV			
Treatment			Zinc plated according to EN ISO 4042:2017, min 5 μ m			

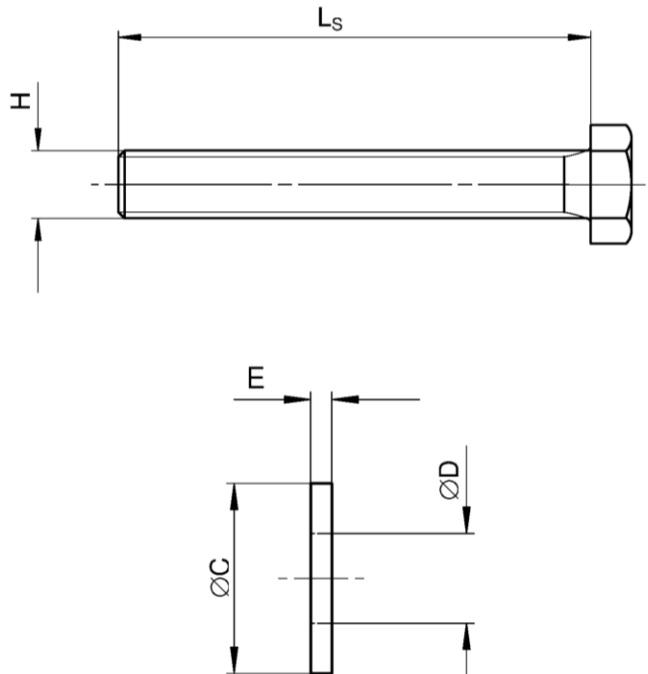

(Fig. not to scale)

fischer Heavy-duty anchor TA M, TA M S, TA M T

Product description
Dimensions
Materials

Annex A 4

Appendix 5 / 10

Specifications of intended use

fischer Heavy-duty anchor	TA M6	TA M8	TA M10	TA M12
Steel, zinc plated			✓	
Static and quasi-static loads			✓	
Uncracked concrete			✓	

Base materials:

- Normal weight concrete according to EN 206-1:2000
- Strength classes C20/25 to C50/60 according to EN 206-1:2000

Use conditions (Environmental conditions):

- Structures subject to dry internal conditions

Design:

- Anchorages have to be designed under the responsibility of an engineer experienced in anchorages and concrete work
- Verifiable calculation notes and drawings have to be prepared taking account of the loads to be anchored. The position of the anchor is indicated on the design drawings (e.g. position of the anchor relative to reinforcement or to supports, etc.)
- Design of fastenings according to FprEN 1992-4: 2016 and EOTA Technical Report TR 055

Installation:

- Anchor installation carried out by appropriately qualified personnel and under the supervision of the person responsible for technical matters of the site
- Hammer or hollow drilling according to Annex B3
- Drill hole created perpendicular +/- 5° to concrete surface, positioning without damaging the reinforcement
- In case of aborted hole: new drilling at a minimum distance twice the depth of the aborted drill hole or smaller distance if the aborted drill hole is filled with high strength mortar and if under shear or oblique tension load it is not in the direction of load application

fischer Heavy-duty anchor TA M, TA M S, TA M T

Intended use
Specifications

Annex B 1

Appendix 6 / 10

Table B2.1: Installation parameters for TA M / TA M S / TA M T

Anchor size		TA M6	TA M8	TA M10	TA M12
Nominal drill hole diameter	d_0	10	12	15	18
Maximum drill bit diameter	$d_{cut} \leq$	10,45	12,50	15,50	18,50
Length of hexagon head screw	$L_s \geq$	$t_{fix} + 50$	$t_{fix} + 55$	$t_{fix} + 70$	$t_{fix} + 85$
Depth of drill hole (TA M / TA M S)	$h_1 \geq$	$L_s - t_{fix} + 15$		$L_s - t_{fix} + 20$	
Depth of drill hole (TA M T)	$h_1 \geq$	$L_s + 10$			
Diameter of clearance hole in the fixture (TA M / TA M S)	d_f [mm]	7	9	12	14
Diameter of clearance hole in the fixture (TA M T)	$d_f \leq$	12	14	18	20
Thickness of fixture	$t_{fix,min}$	1			
	$t_{fix,max}$	150	200	250	300
Required torque moment	T_{inst} [Nm]	10	20	40	75

TA M / TA M S:

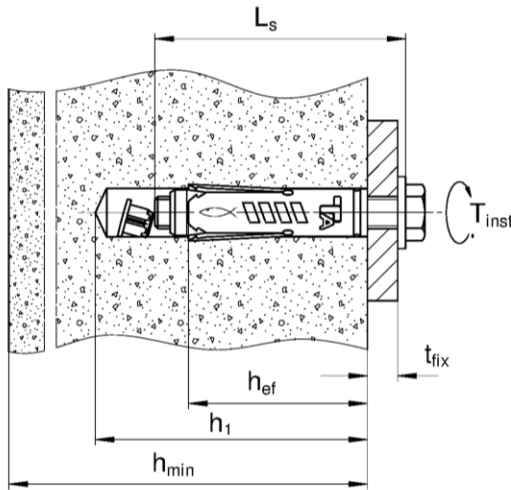

TA M T:

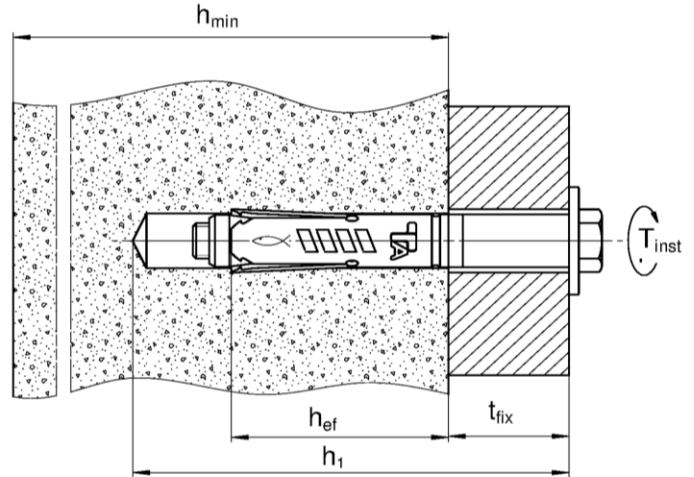

L_s = Length of hexagon head screw
 h_{ef} = Effective embedment depth
 t_{fix} = Thickness of the fixture

h_{min} = Minimum thickness of concrete member
 h_1 = Depth of drill hole to deepest point
 T_{inst} = Required setting torque

Table B2.2: Minimum thickness of concrete member, minimum spacing and minimum edge distances

Anchor size		TA M6	TA M8	TA M10	TA M12
Minimum thickness of concrete member	h_{min}	100	100	110	140
Minimum spacing	s_{min} [mm]	80	90	110	160
Minimum edge distance	c_{min}	50	60	70	120

(Fig. not to scale)

fischer Heavy-duty anchor TA M, TA M S, TA M T

Intended Use

Installation instructions
 Minimum thickness of concrete member, minimum spacing and minimum edge distance

Annex B 2

Installation instruction

Pre-positioned installation TA M / TA M S

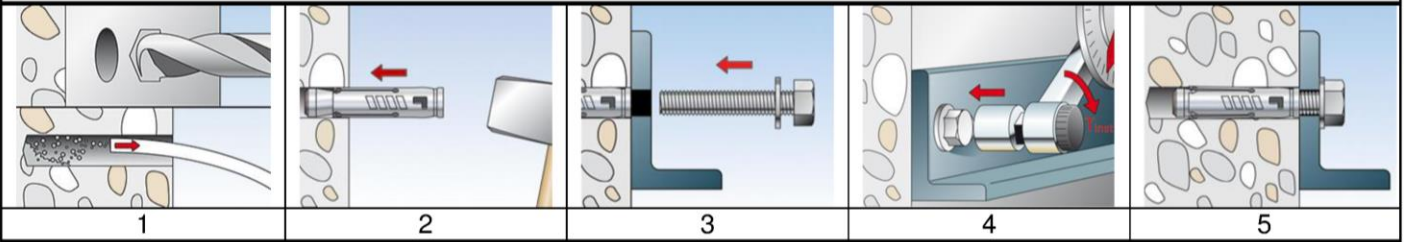

No.	Description	
1	Create drill hole with hammer drill, clean bore hole	Create drill hole with hollow drill and vacuum cleaner
2	Set the fastener	
3	Attach the fixture and turn the screw in	
4	Apply required torque moment T_{inst}	
5	Installed fastener	

Push-through installation TA M T

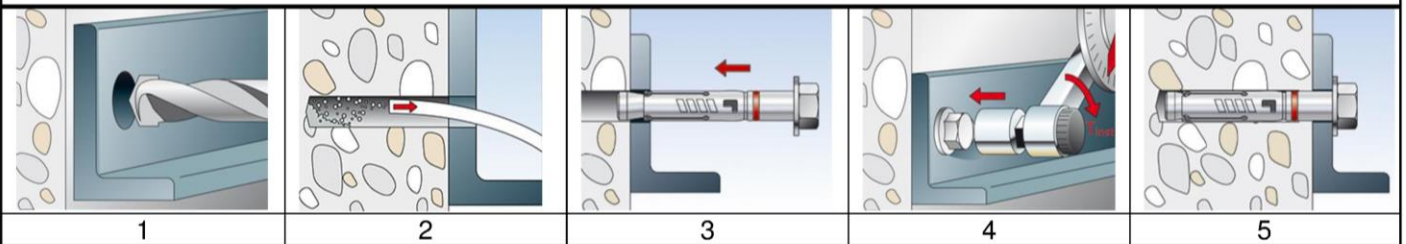

No.	Description	
1	Create drill hole with hammer drill	Create drill hole with hollow drill and vacuum cleaner
2	Clean bore hole	-
3	Set the fastener	
4	Apply required torque moment T_{inst}	
5	Installed fastener	

Types of drills

Hammer drill



Hollow drill



fischer Heavy-duty anchor TA M, TA M S, TA M T

Intended use
Installation instruction

Annex B 3

Appendix 8 / 10

Table C 1.1: Characteristic **tension** resistance under static and quasi-static loads

Anchor size		TA M6	TA M8	TA M10	TA M12		
Steel failure							
Characteristic resistance property class 8.8	$N_{Rk,s}$	[kN]	16,1	29,3	46,4	67,4	
Partial factor	$\gamma_{Ms}^{1)}$	[-]	1,5				
Pull-out failure							
Characteristic resistance in uncracked concrete	$N_{Rk,p}$	[kN]	C20/25	7,5	12	20	25
Increasing factors for $N_{Rk,p}$ for uncracked concrete	ψ_c		C25/30	1,12			
			C30/37	1,22			
			C35/45	1,32			
			C40/50	1,41			
			C45/55	1,50			
			C50/60	1,58			
Installation factor	γ_{inst}	[-]	1,0				
Concrete cone failure and splitting failure							
Effective embedment depth	h_{ef}	[mm]	40	45	55	70	
Factor k_1	$k_{ucr,N}$	[-]	11,0 ²⁾				
Spacing (concrete cone failure)	$s_{cr,N}$	[mm]	120	135	220	210	
Edge distance (concrete cone failure)	$c_{cr,N}$		60	68	110	105	
Spacing (splitting)	$s_{cr,sp}$		120	180	330	420	
Edge distance (splitting)	$c_{cr,sp}$		60	90	165	210	

¹⁾ In absence of other national regulations

²⁾ Based on concrete strength as cylinder strength

fischer Heavy-duty anchor TA M, TA M S, TA M T

Performances

Characteristic **tension** resistance under static and quasi-static loads

Annex C 1

Appendix 9 / 10

Table C2.1: Characteristic values of **shear** resistance under static and quasi-static loads

Anchor size		TA M6	TA M8	TA M10	TA M12
Shear load without lever arm					
Characteristic resistance property class 8.8	$V_{Rk,s}^0$ [kN]	5,8	11,7	19,2	29,8
Partial factor	$\gamma_{Ms}^{1)}$ [-]	1,25			
Ductility factor	k_7 [-]	1,0			
Shear load with lever arm					
Characteristic bending moment property class 8.8	$M_{Rk,s}^0$ [Nm]	12	30	60	105
Partial factor	$\gamma_{Ms}^{1)}$ [-]	1,25			
Concrete pryout failure					
Ductility factor	k_7 [-]	1,0			
Factor	k_8 [-]	1,1	1,8	1,8	2,0
Concrete edge failure					
Effective length of the fastener	l_f [mm]	40	45	55	70
Outside diameter of fastener	d_{nom} [mm]	10	12	15	18

¹⁾ In absence of other national regulations

Table C2.2: Displacements under static and quasi static **tension** loads

Anchor size		TA M6	TA M8	TA M10	TA M12
Tension load in uncracked concrete	[kN]	3,0	4,8	7,9	9,9
Displacements	$\frac{\delta_{N0}}{\delta_{N\infty}}$ [mm]	0,7	0,7	1,2	1,2
		1,0	1,0	1,8	1,8

Table C2.3: Displacements under static and quasi static **shear** loads

Anchor size		TA M6	TA M8	TA M10	TA M12
Shear load in uncracked concrete	[kN]	3,3	6,7	11,0	17,0
Displacements	$\frac{\delta_{V0}}{\delta_{V\infty}}$ [mm]	2,1	1,9	3,1	3,3
		3,1	2,8	4,6	4,9

fischer Heavy-duty anchor TA M, TA M S, TA M T

Performances

Characteristic **shear** resistance under static and quasi-static loads
Displacements under tension and shear loads

Annex C 2

Appendix 10 / 10