

DECLARACIÓN DE PRESTACIONES

DoP 0340

para el sistema de inyección de fischer FIS EB II (Anclaje químico para uso en hormigón)

ES

1. Código de identificación única del producto tipo: DoP 0340
2. Usos previstos: Fijación a posteriori en hormigón fisurado y no fisurado, véase el apéndice, especialmente los anexos B1 - B11.
3. Fabricante: fischerwerke GmbH & Co. KG, Otto-Hahn-Straße 15, 79211 Denzlingen, Alemania
4. Representante autorizado: -
5. Sistemas de evaluación y verificación de la constancia de las prestaciones (EVCP): 1
6. Documento de evaluación europeo: EAD 330499-02-0601, Edition 04/2023
Evaluación técnica europea: ETA-21/0469; 2023-07-25
Organismo de evaluación técnica: DIBt- Deutsches Institut für Bautechnik
Organismos notificados: 2873 TU Darmstadt
7. Prestaciones declaradas:
Resistencia mecánica y estabilidad (BWR 1)
Resistencia característica a tracción (carga estática y cuasi-estática):
 - 1) Resistencia de rotura del acero: véase el apéndice, especialmente los anexos C1, C2
 - 2) Resistencia para la combinación de rotura por cono de hormigón y extracción: véase el apéndice, especialmente los anexos C4 - C6
 - 3) Resistencia de rotura por cono de hormigón: véase el apéndice, especialmente anexo C3
 - 4) Distancia al borde para evitar la rotura del acero sometido a carga: véase el apéndice, especialmente anexo C3
 - 5) Robustez: véase el apéndice, especialmente los anexos C3 - C6
 - 6) Par máximo de montaje: véase el apéndice, especialmente los anexos B3, B5
 - 7) Distancia mínima entre el borde y el centro, Espesor de la base de anclaje: véase el apéndice, especialmente los anexos B3 - B7**Resistencia característica a cortante (carga estática y cuasi-estática):**
 - 8) Resistencia de rotura del acero: véase el apéndice, especialmente los anexos C1, C2
 - 9) Resistencia falla por arrancamiento lateral: véase el apéndice, especialmente anexo C3
 - 10) Resistencia de rotura del hormigón al borde: véase el apéndice, especialmente anexo C3**Desplazamientos bajo carga a corto y largo plazo:**
 - 11) Desplazamientos bajo carga a corto y largo plazo: véase el apéndice, especialmente anexo C7
 - 12) Resistencia del hormigón reforzado con fibras de acero: NPD**Resistencia y desplazamientos característicos para las categorías sísmicas C1 y C2:**
 - 13) Resistencia a carga de tracción, categoría C1: véase el apéndice, especialmente los anexos C8 - C11
 - 14) Resistencia a carga de tracción, categoría C2: véase el apéndice, especialmente los anexos C8 - C10, C12, C13
 - 15) Resistencia a esfuerzo cortante, categoría C1: véase el apéndice, especialmente los anexos C8 - C10
 - 16) Resistencia a esfuerzo cortante, categoría C2: véase el apéndice, especialmente los anexos C8 - C10, C12, C13**Seguridad en caso de incendio (BWR 2)**
 - 17) Reacción al fuego: Clase (A1)**Resistencia al fuego:**
 - 18) Resistencia al fuego, rotura del acero (carga de tracción): véase el apéndice, especialmente los anexos C14, C15
 - 19) Resistencia de la adherencia en condiciones de incendio: véase el apéndice, especialmente anexo C16
 - 20) Resistencia al fuego, rotura del acero (esfuerzo cortante): véase el apéndice, especialmente los anexos C14, C15**Higiene, salud y medio ambiente (BWR 3)**
 - 21) Contenido, emisión y/o desprendimiento de sustancias peligrosas: NPD
8. Documentación técnica adecuada o documentación técnica específica: -

Las prestaciones del producto identificado anteriormente son conformes con el conjunto de prestaciones declaradas. La presente declaración de prestaciones se emite, de conformidad con el Reglamento (UE) no 305/2011, bajo la sola responsabilidad del fabricante arriba identificado.

Firmado por y en nombre del fabricante por:



Dr.-Ing. Oliver Geibig, Director General Unidades de Negocio e Ingeniería
Tumlingen, 2023-08-15

Jürgen Grün, Director General de Química y Calidad

Esta DdR se ha preparado en distintos idiomas. En caso de que haya alguna controversia sobre la interpretación prevalecerá siempre la versión inglesa.

El Apéndice incluye información voluntaria y complementaria en idioma inglés que excede los requisitos legales (de idioma neutral).

Translation guidance Essential Characteristics and Performance Parameters for Annexes

Glosario de parámetros esenciales, característicos y de prestaciones para los anexos

Mechanical resistance and stability (BWR 1)		
Resistencia mecánica y estabilidad (BWR 1)		
Characteristic resistance to tension load (static and quasi-static loading):		
Resistencia característica a tracción (carga estática y cuasi-estática):		
1	Resistance to steel failure: Resistencia de rotura del acero:	$N_{Rk,s}$ [kN]
2	Resistance to combined pull-out and concrete cone failure: Resistencia para la combinación de rotura por cono de hormigón y extracción:	T_{Rk} and/or $T_{Rk,100}$ [N/mm ²], $\psi_c, \psi_{sus}, \psi_{sus,100}$ [-] (BF)
	Resistance to pull-out failure: Résistance à la rupture par extraction	$N_{Rk,p}$ and/or $N_{Rk,p,100}$ [kN], ψ_c [-] (BEF)
3	Resistance to concrete cone failure: Resistencia de rotura por cono de hormigón:	$c_{cr,N}$ [mm], $k_{cr,N}$, $k_{ucr,N}$ [-]
4	Edge distance to prevent splitting under load: Distancia al borde para evitar la rotura del acero sometido a carga:	$c_{cr,sp}$ [mm]
5	Robustness: Robustez:	γ_{inst} [-]
6	Maximum installation torque: Par máximo de montaje:	$\max T_{inst}$ [Nm] (BF)
	Installation torque: Par de montaje:	T_{inst} [Nm] (BEF)
7	Minimum edge distance, spacing and member thickness: Distancia mínima entre el borde y el centro, Espesor de la base de anclaje:	$c_{min}, s_{min}, h_{min}$ [mm]
Characteristic resistance to shear load (static and quasi-static loading):		
Resistencia característica a cortante (carga estática y cuasi-estática):		
8	Resistance to steel failure: Resistencia de rotura del acero:	$V_{Rk,s}$ [kN], $M_{Rk,s}^0$ [Nm], k_7 [-]
9	Resistance to pry-out failure: Resistencia falla por arrancamiento lateral:	k_8 [-]
10	Resistance to concrete edge failure: Resistencia de rotura del hormigón al borde:	d_{nom}, l_f [mm]
Displacements under short-term and long-term loading:		
Desplazamientos bajo carga a corto y largo plazo:		
11	Displacements under short-term and long-term loading: Desplazamientos bajo carga a corto y largo plazo:	δ_0, δ_∞ [mm or mm/(N/mm ²)]
12	Resistance in steel fibre reinforced concrete: Resistencia del hormigón reforzado con fibras de acero:	Description
Characteristic resistance and displacements for seismic performance categories C1 and C2:		
Resistencia y desplazamientos característicos para las categorías sísmicas C1 y C2:		
13	Resistance to tension for seismic performance category C1 Resistencia a carga de tracción, categoría C1:	$N_{Rk,s,C1}$ [kN] (all) $T_{Rk,C1}$ [N/mm ²] (BF) $N_{Rk,p,C1}$ [kN] (BEF)
14	Resistance to tension for seismic performance category C2 Resistencia a carga de tracción, categoría C2:	$N_{Rk,s,C2}$ [kN] (all) $T_{Rk,C2}$ [N/mm ²] (BF) $N_{Rk,p,C2}$ [kN] (BEF) $\delta_{N,C2}$ [mm] (all)
15	Resistance to tension for seismic performance category C1 Resistencia a esfuerzo cortante, categoría C1:	$V_{Rk,s,C1}$ [kN] (all)
16	Resistance to tension for seismic performance category C2 Resistencia a esfuerzo cortante, categoría C2:	$V_{Rk,s,C2}$ [kN] (all) $\delta_{V,C2}$ [mm] (all)
Hygiene, health and the environment (BWR 3)		
Higiene, salud y medio ambiente (BWR 3)		
17	Reaction to fire Reacción al fuego:	Class Clase (A1)
Resistance to fire		
Resistencia al fuego:		
18	Fire resistance to steel failure (tension load): Resistencia al fuego, rotura del acero (carga de tracción):	$N_{Rk,s,fi}$ [kN]
19	Bond resistance under fire conditions: Resistencia de la adherencia en condiciones de incendio:	$k_{fi,p}(\theta)$ [-], $T_{Rk,fi}(\theta)$ [N/mm ²] (BF)
20	Fire resistance to steel failure under shear loading: Resistencia al fuego, rotura del acero (esfuerzo cortante):	$V_{Rk,s,fi}$ [kN], $M_{Rk,s,fi}^0$ [Nm]
Hygiene, health and the environment (BWR 3)		
Higiene, salud y medio ambiente (BWR 3)		
21	Content, emission and/or release of dangerous substances: Contenido, emisión y/o desprendimiento de sustancias peligrosas:	Description/Level

Specific Part

1 Technical description of the product

The fischer injection system FIS EB II is a bonded fastener consisting of a cartridge with injection mortar fischer FIS EB II and a steel element according to Annex A 4.

The steel element is placed into a drilled hole filled with injection mortar and is anchored via the bond between metal part, injection mortar and concrete.

The product description is given in Annex A.

2 Specification of the intended use in accordance with the applicable European Assessment Document

The performances given in Section 3 are only valid if the anchor is used in compliance with the specifications and conditions given in Annex B.

The verifications and assessment methods on which this European Technical Assessment is based lead to the assumption of a working life of the anchor of at least 50 years. The indications given on the working life cannot be interpreted as a guarantee given by the producer, but are to be regarded only as a means for choosing the right products in relation to the expected economically reasonable working life of the works.

3 Performance of the product and references to the methods used for its assessment

3.1 Mechanical resistance and stability (BWR 1)

Essential characteristic	Performance
Characteristic resistance to tension load (static and quasi-static loading)	See Annex C 1 to C 6, B 3 to B7
Characteristic resistance to shear load (static and quasi-static loading)	See Annex C 1 to C 3
Displacements under short-term and long-term loading	See Annex C 7
Characteristic resistance and displacements for seismic performance categories C1 and C2	See Annex C 8 to C 13

3.2 Safety in case of fire (BWR 2)

Essential characteristic	Performance
Reaction to fire	Class A1
Resistance to fire	See Annex C 14 to C 16

3.3 Hygiene, health and the environment (BWR 3)

Essential characteristic	Performance
Content, emission and/or release of dangerous substances	No performance assessed

4 Assessment and verification of constancy of performance (AVCP) system applied, with reference to its legal base

In accordance with EAD 330499-02-0601 the applicable European legal act is: [96/582/EC].

The system to be applied is: 1

Installation conditions part 1

fischer anchor rod FIS A / RG (Anchor rod) and commercial standard threaded rods (Threaded rod)

Pre-positioned installation

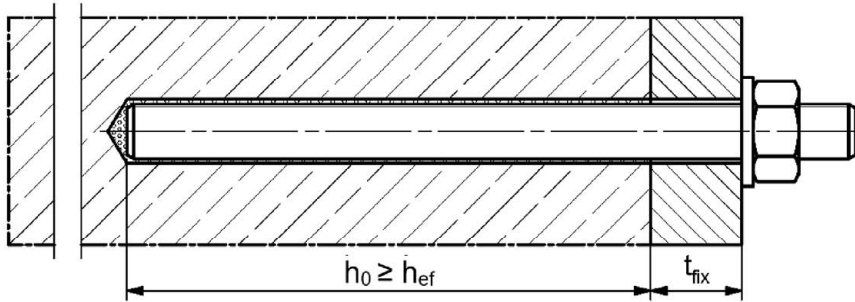

Push through installation (annular gap filled with mortar)

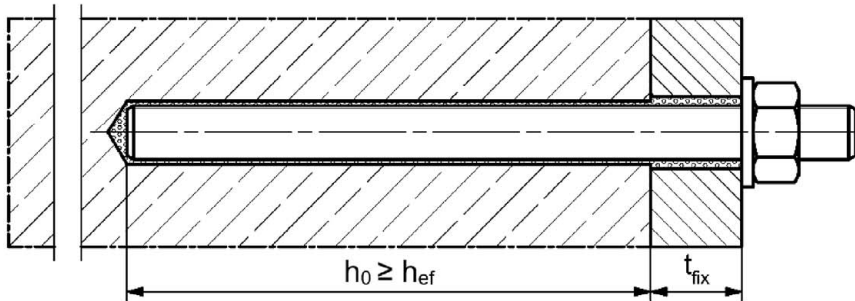

Pre-positioned or push through installation with subsequently injected filling disk (annular gap filled with mortar)

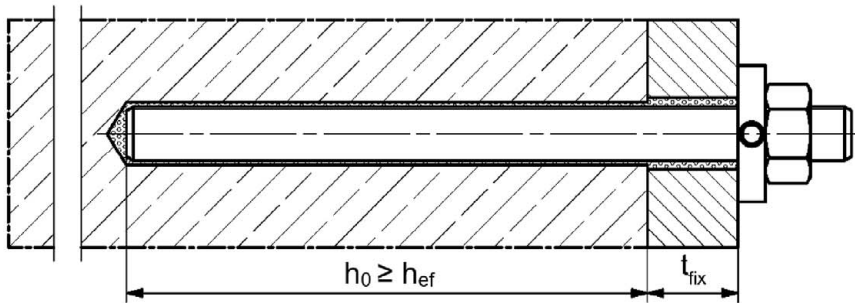

Figures not to scale

h_0 = drill hole depth

h_{ef} = effective embedment depth

t_{fix} = thickness of fixture

fischer injection system FIS EB II

Product description
Installation conditions part 1

Annex A 1

Appendix 3 / 34

Installation conditions part 2

Reinforcing bar (Rebar)

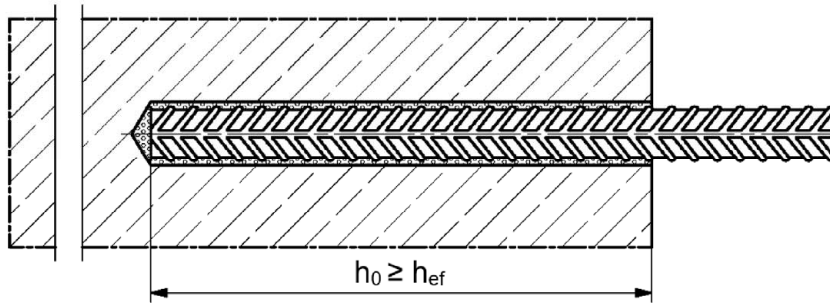

fischer rebar anchor FRA (fischer FRA)

Pre-positioned installation

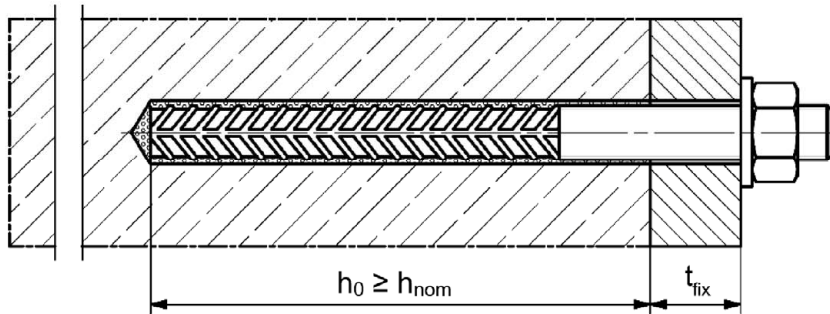

Push through installation (annular gap filled with mortar)

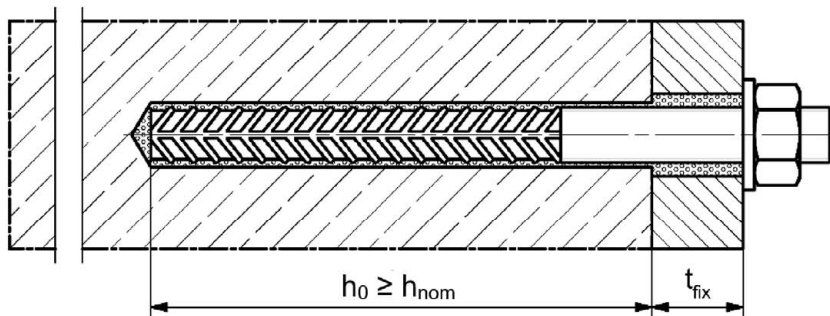

Figures not to scale

h_0 = drill hole depth

h_{ef} = effective embedment depth

t_{fix} = thickness of fixture

h_{nom} = overall fastener embedment depth in the concrete

fischer injection system FIS EB II

Product description
Installation conditions part 2

Annex A 2

Appendix 4 / 34

Overview system components part 1

Injection cartridge (shuttle cartridge) with sealing cap; Size: 390 ml, 585 ml, 1100 ml, 1500 ml

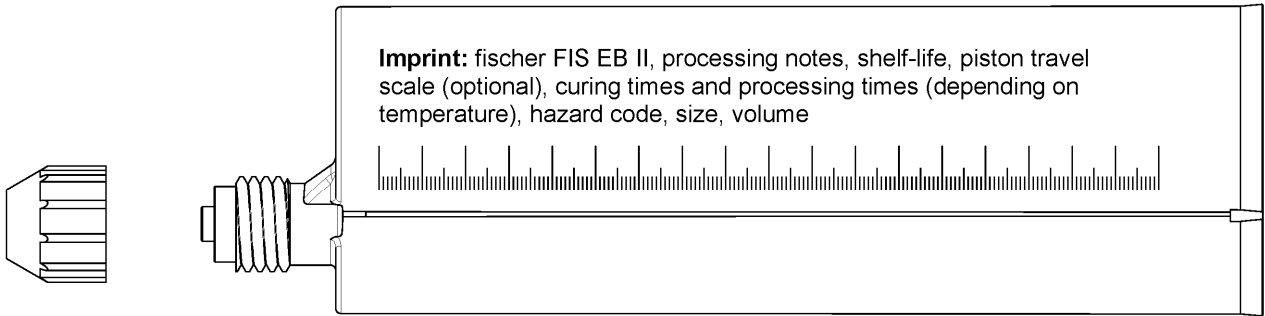

Static mixer FIS MR Plus for Injection cartridge 390 ml

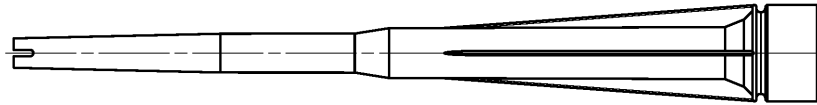

Static mixer FIS UMR Injection cartridges ≥ 585 ml

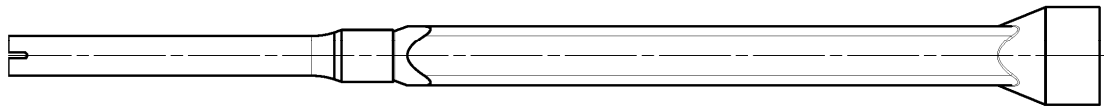

**Injection adapter and extension tube $\varnothing 9$ for static mixer FIS MR Plus;
Injection adapter and extension tube $\varnothing 9$ or $\varnothing 15$ for static mixer FIS UMR**

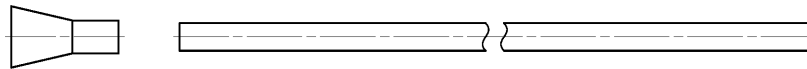

Cleaning brush BS



Blow-out pump AB G



Compressed-air cleaning tool ABP



Figures not to scale

fischer injection system FIS EB II

Product description

Overview system components part 1; cartridges / static mixer / accessories

Annex A 3

Appendix 5 / 34

Overview system components part 2

Anchor rod

Size: M8, M10, M12, M16, M20, M24, M27, M30

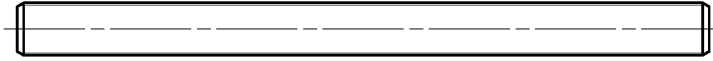

Washer / hexagon nut

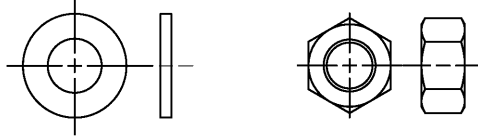

fischer filling disk with injection adapter

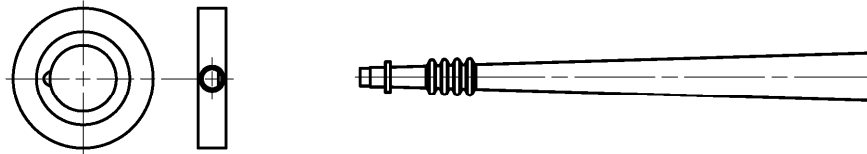

Rebar

Nominal diameter: $\phi 8$, $\phi 10$, $\phi 12$, $\phi 14$, $\phi 16$, $\phi 20$, $\phi 25$, $\phi 26$, $\phi 28$, $\phi 30$, $\phi 32$

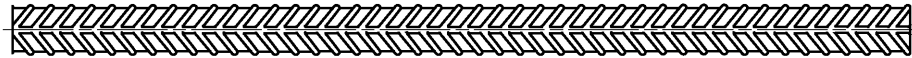

fischer FRA, FRA HCR

Size: M12, M16, M20, M24



Figures not to scale

fischer injection system FIS EB II

Product description

Overview system components part 2; steel components, injection adapter

Annex A 4

Appendix 6 / 34

Table A5.1: Materials

Part	Designation	Material		
1	Injection cartridge	Mortar, hardener, filler		
	Steel grade	Steel zinc plated	Stainless steel R acc. to EN 10088-1:2014 Corrosion resistance class CRC III acc. to EN 1993-1-4:2006+A1:2015	High corrosion resistant steel HCR acc. to EN 10088-1:2014 Corrosion resistance class CRC V acc. to EN 1993-1-4:2006+A1:2015
2	Anchor rod or Threaded rod	Property class 4.8, 5.8 or 8.8; EN ISO 898-1:2013 electroplated $\geq 5 \mu\text{m}$, DIN EN ISO 4042:2022 or hot dip galvanised $\geq 40 \mu\text{m}$ EN ISO 10684:2004+AC:2009 $f_{uk} \leq 1000 \text{ N/mm}^2$ fracture elongation $A_5 > 12 \%$	Property class 50, 70 or 80; EN ISO 3506-1:2020 1.4401; 1.4404; 1.4578; 1.4571; 1.4439; 1.4362; 1.4062, 1.4662, 1.4462; EN 10088-1:2014 $f_{uk} \leq 1000 \text{ N/mm}^2$ fracture elongation $A_5 > 12 \%$	Property class 50 or 80; EN ISO 3506-1:2020 or property class 70 1.4565; 1.4529; EN 10088-1:2014 $f_{uk} \leq 1000 \text{ N/mm}^2$ fracture elongation $A_5 > 12 \%$
		Fracture elongation $A_5 > 8 \%$ for applications without requirements for seismic performance category C2		
3	Washer ISO 7089:2000	electroplated $\geq 5 \mu\text{m}$, EN ISO 4042:2022 or hot dip galvanised $\geq 40 \mu\text{m}$ EN ISO 10684:2004+AC:2009	1.4401; 1.4404; 1.4578; 1.4571; 1.4439; 1.4362; EN 10088-1:2014	1.4565; 1.4529; EN 10088-1:2014
4	Hexagon nut	Property class 5 or 8 acc. EN ISO 898-2:2012 electroplated $\geq 5 \mu\text{m}$, EN ISO 4042:2022 or hot dip galvanised $\geq 40 \mu\text{m}$ EN ISO 10684:2004+AC:2009	Property class 50, 70 or 80 acc. EN ISO 3506-2:2020 1.4401; 1.4404; 1.4578; 1.4571; 1.4439; 1.4362; EN 10088-1:2014	Property class 50, 70 or 80 acc. EN ISO 3506-2:2020 1.4565; 1.4529 EN 10088-1:2014
5	fischer filling disk	electroplated $\geq 5 \mu\text{m}$, EN ISO 4042:2022 or hot dip galvanised $\geq 40 \mu\text{m}$ EN ISO 10684:2004+AC:2009	1.4401; 1.4404; 1.4578; 1.4571; 1.4439; 1.4362; EN 10088-1:2014	1.4565; 1.4529; EN 10088-1:2014
6	Rebar EN 1992-1-1:2004 and AC:2010, Annex C	Bars and de-coiled rods, class B or C with f_{yk} and k according to NDP or NCI according to EN 1992-1-1/NA $f_{uk} = f_{tk} = k \cdot f_{yk} (A_5 > 12 \%)$		
		Fracture elongation $A_5 > 8 \%$ for applications without requirements for seismic performance category C2		
7	fischer FRA	Rebar part: Bars and de-coiled rods class B or C with f_{yk} and k according to NDP or NCI of EN 1992-1-1:2004+AC:2010 $f_{uk} = f_{tk} = k \cdot f_{yk} (A_5 > 12 \%)$ Threaded part: Property class 80 EN ISO 3506-1:2020	1.4401, 1.4404, 1.4571, 1.4578, 1.4439, 1.4362, 1.4062 acc. to EN 10088-1:2014 Corrosion resistance class CRC III acc. to EN 1993-1-4:2006+A1:2015 1.4565; 1.4529 acc. to EN 10088-1:2014 Corrosion resistance class CRC V acc. to EN 1993-1-4: 2006+A1:2015 $f_{uk} \leq 1000 \text{ N/mm}^2$; fracture elongation $A_5 > 12 \%$	
		Fracture elongation $A_5 > 8 \%$ for applications without requirements for seismic performance category C2		

fischer injection system FIS EB II





Product description
Materials

Annex A 5

Appendix 7 / 34

Specifications of intended use part 1

Table B1.1: Overview use and performance categories

Anchorages subject to		FIS EB II with ...					
		Anchor rod, Threaded rod 		Rebar 		fischer FRA 	
Hammer drilling with standard drill bit 		all sizes					
Static and quasi-static loading, in	uncracked concrete	all sizes	Tables: C1.1	all sizes	Tables: C2.1	all sizes	Tables: C2.2
	cracked concrete		C3.1		C3.1		C3.1
Use category	I1 dry or wet concrete	all sizes					
	I2 water filled hole	all sizes					
Seismic performance category	C1	Tables: C8.1 C9.3 C10.1 C11.1	Tables: C9.1 C9.3 C10.1 C11.2	Tables: C9.2 C9.3 C10.1 C11.2			
	C2	Tables: C8.1 C10.1 C12.1	Tables: C9.1 C10.1 C13.1	Tables: C9.2 C10.1 C13.1			
Installation direction		D3 (downward and horizontal and upwards (e.g. overhead))					
Installation temperature		$T_{i,min} = +5\text{ °C}$ to $T_{i,max} = +40\text{ °C}$					
Resistance to fire		Tables: C14.1 Annex: C 16	Tables: C15.1 Annex: C 16	Tables: C15.1 Annex C 16			
Service temperature	Temperature range I	-40 °C to +43 °C	(max. short term temperature +43 °C; max. long term temperature +24 °C)				
	Temperature range II	-40 °C to +60 °C	(max. short term temperature +60 °C; max. long term temperature +43 °C)				
	Temperature range III	-40 °C to +72 °C	(max. short term temperature +72 °C; max. long term temperature +50 °C)				

¹⁾ No performance assessed

fischer injection system FIS EB II

Intended use
Specifications part 1

Annex B 1

Appendix 8 / 34

Specifications of intended use part 2

Base materials:

- Compacted reinforced or unreinforced normal weight concrete without fibres of strength classes C20/25 to C50/60 according to EN 206:2013+A2:2021.

Use conditions (Environmental conditions):

- Structures subject to dry internal conditions (zinc coated steel, stainless steel or high corrosion resistant steel).
- For all other conditions according to EN1993-1-4:2006+A1:2015 corresponding to corrosion resistance classes to Annex A 5 Table 5.1.

Design:

- Fastenings are designed under the responsibility of an engineer experienced in fastenings and concrete work.
- Verifiable calculation notes and drawings are to be prepared taking account of the loads to be anchored. The position of the fastener is indicated on the design drawings (e. g. position of the fastener relative to reinforcement or to supports, etc.).
- Fastenings are designed in accordance with: EN 1992-4:2018 and TR 082 from June 2023.

Installation:

- Fastener installation is to be carried out by appropriately qualified personnel and under the supervision of the person responsible for technical matters of the site.
- Fastening depth should be marked and adhered to installation.
- Overhead installation is allowed (necessary equipment see installation instruction).

fischer injection system FIS EB II

Intended use
Specifications part 2

Annex B 2

Appendix 9 / 34

Table B3.1: Installation parameters for Anchor rods

Anchor rods		M8	M10	M12	M16	M20	M24	M27	M30	
Nominal drill hole diameter	d_0	10	12	14	18	24	28	30	35	
Drill hole depth	h_0	$h_0 \geq h_{ef}$								
Effective embedment depth	$h_{ef, min}$	60	60	70	80	90	96	108	120	
	$h_{ef, max}$	160	200	240	320	400	480	540	600	
Simplified spacing and edge distance ¹⁾	s = c	40	45	55	65	85	105	120	140	
	[mm]									
Diameter of the clearance hole of the fixture	pre-positioned installation d_f	9	12	14	18	22	26	30	33	
	push through installation d_f	12	14	16	20	26	30	33	40	
Minimum thickness of concrete member	h_{min}	$h_{ef} + 30$ (≥ 100)			$h_{ef} + 2d_0$					
Maximum installation torque	$\max T_{inst}$	[Nm]	10	20	40	60	120	150	200	300

¹⁾ Detailed calculation according to Annex B 6 and B 7

Anchor rod

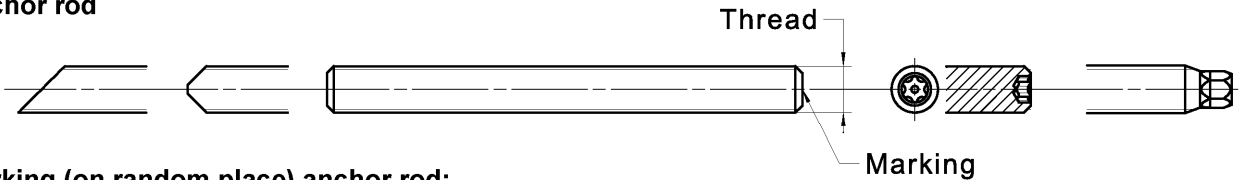

Marking (on random place) anchor rod:

Steel electroplated PC ¹⁾ 8.8	• or +	Steel hot-dip PC ¹⁾ 8.8	•
High corrosion resistant steel HCR PC ¹⁾ 50	•	High corrosion resistant steel HCR PC ¹⁾ 70	-
High corrosion resistant steel HCR PC ¹⁾ 80	(Stainless steel R property class 50	~
Stainless steel R property class 80	*		

Alternatively: Colour coding according to DIN 976-1: 2016

¹⁾ PC = property class

Installation conditions:

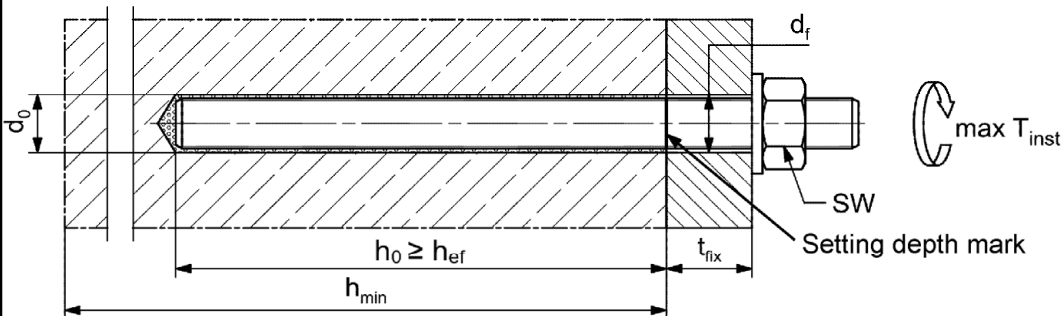

Threaded rods, washers and hexagon nuts may also be used if the following requirements are fulfilled

- Materials, dimensions and mechanical properties according to Annex A 5, Table A5.1
- Inspection certificate 3.1 according to EN 10204:2004, the documents shall be stored
- Setting depth is marked

Figures not to scale

fischer injection system FIS EB II

Intended use
Installation parameters Anchor rods

Annex B 3

Appendix 10 / 34

Table B4.1: Installation parameters for Rebars

Nominal diameter of the rebar		ϕ	8 ¹⁾		10 ¹⁾		12 ¹⁾		14	16	20	25	26	28	30	32	
Nominal drill hole diameter	d_0	[mm]	10	12	12	14	14	16	18	20	25	30	35	35	40	40	
Drill hole depth	h_0		$h_0 \geq h_{ef}$														
Effective embedment depth	$h_{ef,min}$		60	60	70	75	80	90	100	104	112	120	128				
	$h_{ef,max}$		160	200	240	280	320	400	500	520	560	600	640				
Simplified spacing and edge distance ²⁾	$s = c$		40	45	55	60	65	85	120	120	140	140	160				
Minimum thickness of concrete member	h_{min}	$h_{ef} + 30$ (≥ 100)						$h_{ef} + 2d_0$									

1) Both drill hole diameters can be used

2) Detailed calculation according to Annex B 6 und B 7

Rebar

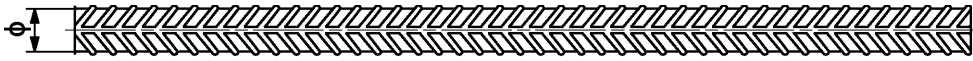

- The minimum value of related rib area $f_{R,min}$ must fulfil the requirements of EN 1992-1-1:2004+AC:2010
- The rib height must be within the range: $0,05 \cdot \phi \leq h_{rib} \leq 0,07 \cdot \phi$
(ϕ = Nominal diameter of the rebar, h_{rib} = rib height)

Installation conditions:

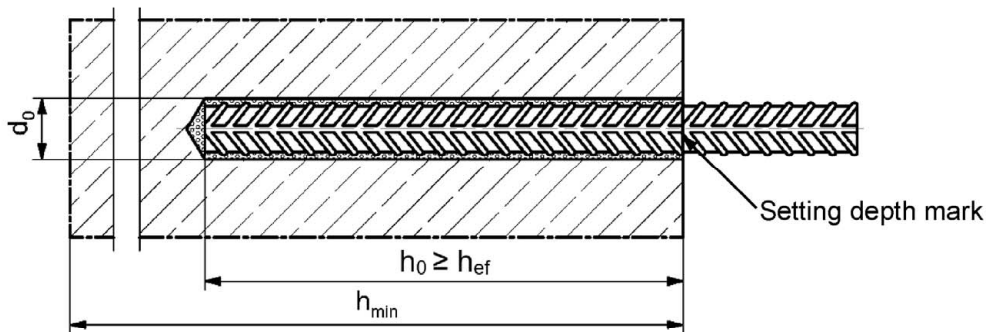

Figures not to scale

fischer injection system FIS EB II

Intended use
Installation parameters Rebars

Annex B 4

Appendix 11 / 34

Table B5.1: Installation parameters for fischer FRA

fischer FRA		M12 ¹⁾		M16	M20	M24	
Nominal diameter of the rebar	ϕ	12		16	20	25	
Nominal drill hole diameter	d_0	14	16	20	25	30	
Drill hole depth	h_0	$h_{ef} + l_e$					
Effective embedment depth	$h_{ef,min}$	70		80	90	96	
	$h_{ef,max}$	140		220	300	380	
Distance concrete surface to welded joint	l_e	100					
Simplified spacing and edge distance ²⁾	$s = c$	[mm]		55	65	85	105
Diameter of clearance hole in the fixture	pre-positioned anchorage $\leq d_f$	14		18	22	26	
	push through anchorage $\leq d_f$	18		22	26	32	
Minimum thickness of concrete member	h_{min}	$h_0 + 30$ (≥ 100)	$h_0 + 2d_0$				
Maximum torque moment for attachment of the fixture	$\max T_{inst}$	[Nm]	40	60	120	150	

¹⁾ Both drill hole diameters can be used

²⁾ Detailed calculation according to Annex B 6 and B 7

fischer FRA

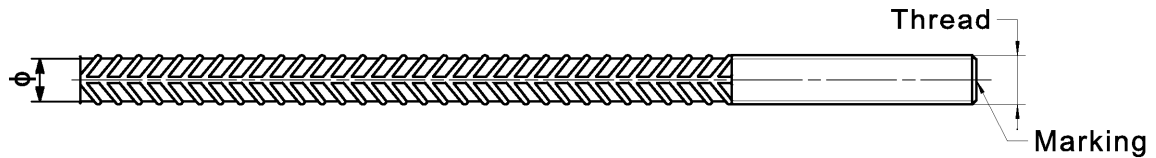

Marking frontal e. g:

- FRA (for stainless steel);
- FRA HCR (for high corrosion resistant steel)

Installation conditions:

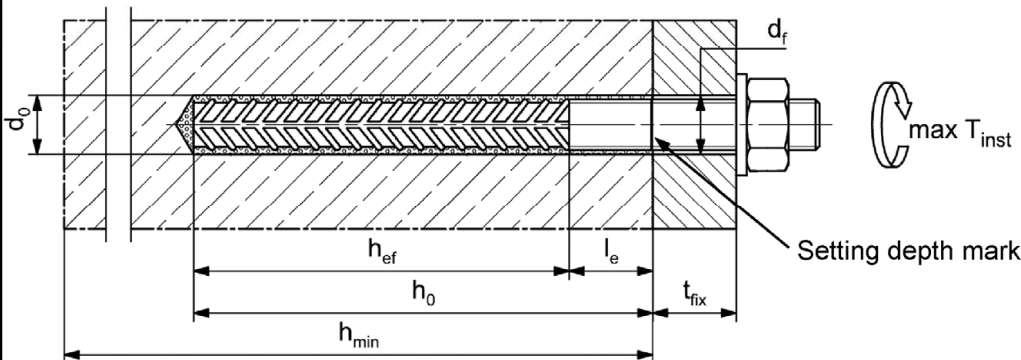

Figures not to scale

fischer injection system FIS EB II

Intended use
Installation parameters fischer FRA

Annex B 5

Appendix 12 / 34

Table B6.1: Minimum spacing and minimum edge distance for Anchor rods, Rebars and fischer FRA

Anchor rods		M8	M10	M12	-	M16	M20	
Rebars / fischer FRA (nominal diameter)	ϕ	8	10	12	14	16	20	
Minimum edge distance								
Uncracked / cracked concrete	c_{min}	[mm]	40	45	45	45	50	55
Spacing	s		according to Annex B 7					
Minimum spacing								
Uncracked / cracked concrete	s_{min}	[mm]	40	45	55	60	65	85
Edge distance	c		according to Annex B 7					
Required projecting area								
Uncracked concrete	$A_{sp,req}$	[1000 mm ²]	8,0	13,0	22,0	23,0	24,0	38,5
Cracked concrete			6,5	10,0	16,5	17,5	18,5	29,5

Anchor rods		M24	-	-	M27	-	M30	-	
Rebars / fischer FRA (nominal diameter)	ϕ	-	25	26	-	28	30	32	
Minimum edge distance									
Uncracked / cracked concrete	c_{min}	[mm]	60	75	75	75	80	80	120
Spacing	s		according to Annex B 7						
Minimum spacing									
Uncracked / cracked concrete	s_{min}	[mm]	105	120	120	120	140	140	160
Edge distance	c		according to Annex B 7						
Required projecting area									
Uncracked concrete	$A_{sp,req}$	[1000 mm ²]	40,0	47,5	47,5	47,5	64,0	64,0	64,0
Cracked concrete			30,5	36,5	36,5	36,5	49,0	49,0	49,0

Splitting failure for minimum edge distance and spacing in dependence of the effective embedment depth h_{ef} .

For the calculation of minimum spacing and minimum edge distance of anchors in combination with different embedment depths and thicknesses of concrete members the following equation shall be fulfilled:

$$A_{sp,req} < A_{sp}$$

$A_{sp,req}$ = required projecting area

A_{sp} = projecting area (according to Annex B 7)

fischer injection system FIS EB II

Intended use
Minimum spacing and edge distance for Anchor rods, Rebars and fischer FRA

Annex B 6

Appendix 13 / 34

Table B7.1: Projecting area A_{sp} with concrete member thickness
 $h > h_{ef} + 1,5 \cdot c$ and $h \geq h_{min}$

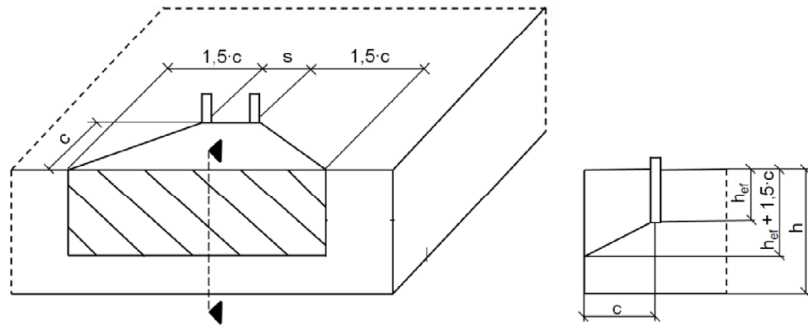

Single fastener	$A_{sp} = (3 \cdot c) \cdot (h_{ef} + 1,5 \cdot c)$	[mm ²]	with $c \geq c_{min}$
Group of fastener with $s > 3 \cdot c$	$A_{sp} = (6 \cdot c) \cdot (h_{ef} + 1,5 \cdot c)$	[mm ²]	
Group of fastener with $s \leq 3 \cdot c$	$A_{sp} = (3 \cdot c + s) \cdot (h_{ef} + 1,5 \cdot c)$	[mm ²]	

Table B7.2: Projecting area A_{sp} with concrete member thickness
 $h \leq h_{ef} + 1,5 \cdot c$ and $h \geq h_{min}$

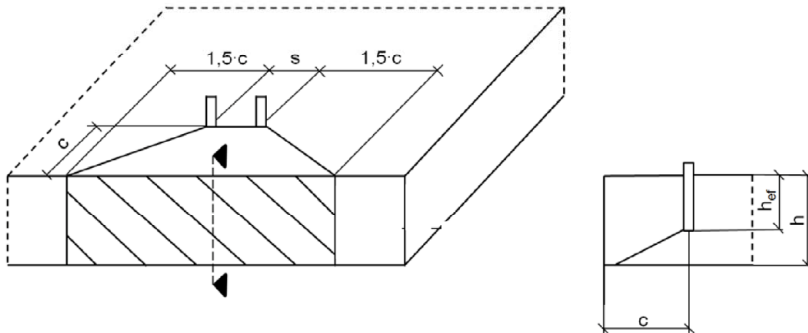

Single fastener	$A_{sp} = 3 \cdot c \cdot \text{existing } h$	[mm ²]	with $c \geq c_{min}$
Group of fastener with $s > 3 \cdot c$	$A_{sp} = 6 \cdot c \cdot \text{existing } h$	[mm ²]	
Group of fastener with $s \leq 3 \cdot c$	$A_{sp} = (3 \cdot c + s) \cdot \text{existing } h$	[mm ²]	

Edge distance and axial spacing shall be rounded up to at least 5 mm

Figures not to scale

fischer injection system FIS EB II

Intended use

Minimum thickness of concrete member for Anchor rods, Rebar, fischer FRA and minimum spacing and edge distance

Annex B 7

Appendix 14 / 34

Table B8.1: Parameters of the cleaning brush BS (steel brush with steel bristles)

The size of the cleaning brush refers to the drill hole diameter

Nominal drill hole diameter	d_0	[mm]	10	12	14	16	18	20	24	25	28	30	35	40
Steel brush diameter BS	d_b		11	14	16	20		25	26	27	30	40		42

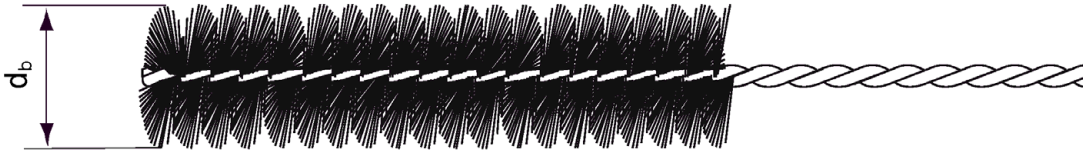

Table B8.2: Conditions for use static mixer without an extension tube

Nominal drill hole diameter	d_0	[mm]	10	12	14	16	18	20	24	25	28	30	35	40
Drill hole depth h_0 by using	FIS MR Plus		≤ 90	≤ 120	≤ 140	≤ 150	≤ 160	≤ 190	≤ 210					
	FIS UMR		-	-	≤ 90	≤ 160	≤ 180	≤ 190	≤ 220	≤ 250				

Table B8.3 Maximum processing time of the mortar and minimum curing time
(During the curing time of the mortar the concrete temperature may not fall below the listed minimum temperature)

Temperature at anchoring base [°C]	Maximum processing time t_{work}	Minimum curing time t_{cure}
> 5 to 10	180 min	96 h
> 10 to 15	90 min	60 h
> 15 to 20	60 min	36 h
> 20 to 30	30 min	24 h
> 30 to 40	15 min	12 h

fischer injection system FIS EB II

Intended use
Cleaning brush (steel brush)
Processing time and curing time

Annex B 8



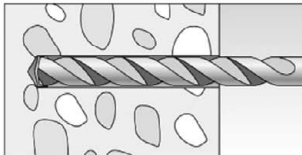
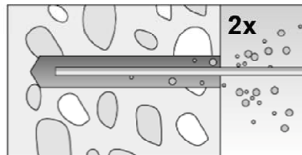
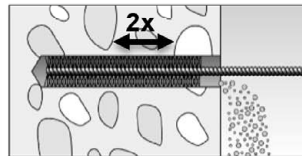
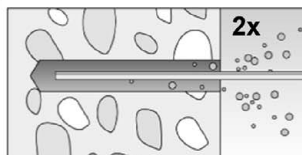
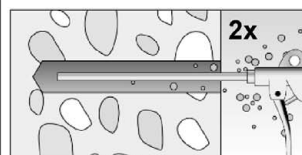

Appendix 15 / 34

Installation instructions part 1

Drilling and cleaning the hole (hammer drilling with standard drill bit)

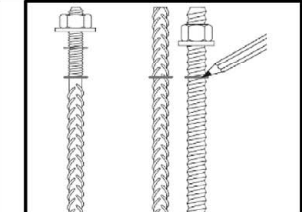
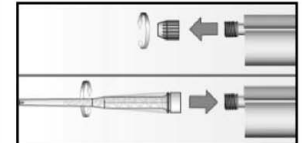
1		<p>Drill the hole. Nominal drill hole diameter d_0 and drill hole depth h_0 see Tables B3.1, B4.1, B5.1.</p>
2		<p>Clean the drill hole: For $h_{ef} \leq 12d$ and $d_0 < 18$ mm blow out the hole twice by hand.</p>
3		<p>Brush the drill hole twice. For drill hole diameter $d_0 \geq 18$ mm and / or $h_{ef} > 12d$ use a power drill. For deep holes use an extension. Corresponding brushes see Table B8.1.</p>
4		<p>Clean the drill hole: For $h_{ef} \leq 12d$ and $d_0 < 18$ mm blow out the hole twice by hand.</p>
		 <p>For $h_{ef} > 12d$ and / or $d_0 \geq 18$ mm blow out the hole twice with oil-free compressed air ($p \geq 6$ bar).</p>

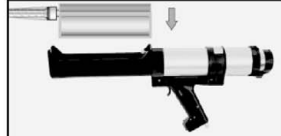
Preparing

5		<p>Mark the setting depth of the steel element</p>
6		<p>Remove the sealing cap Screw on the static mixer (the spiral in the static mixer must be clearly visible).</p>
7		 <p>Place the cartridge into the dispenser.</p>
8		 <p>Extrude approximately 10 cm of material out until the resin is evenly grey in colour. Do not use mortar that is not uniformly grey.</p>

Go to Step 9

fischer injection system FIS EB II

Intended use
Installation instructions part 1

Annex B 9



Appendix 16 / 34

Installation instructions part 2

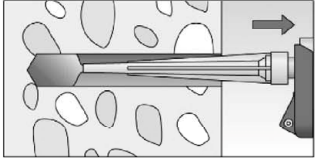
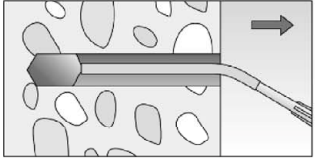
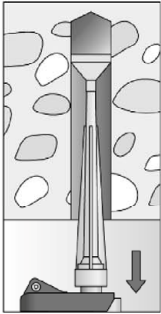
Injection of the mortar

<p>9</p>	 <p>Fill approximately 2/3 of the drill hole with mortar. Always begin from the bottom of the hole and avoid bubbles.</p>	 <p>The conditions for mortar injection without extension tube can be found in Table B8.2</p> <p>For deeper drill holes, than those mentioned in Table B8.2, use a suitable extension tube.</p>	 <p>For overhead installation, deep holes ($h_0 > 250$ mm) or drill hole diameter ($d_0 \geq 30$ mm) use an injection-adaptor.</p>
----------	--	--	--

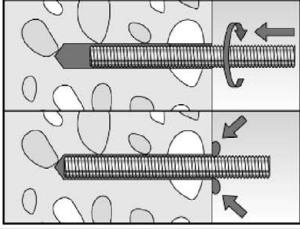
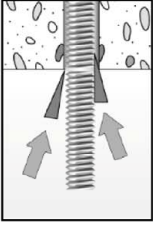
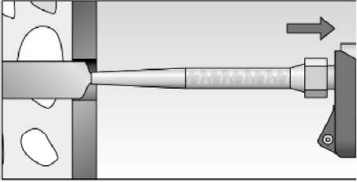
Installation of Anchor rods

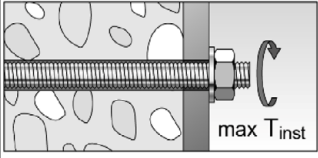
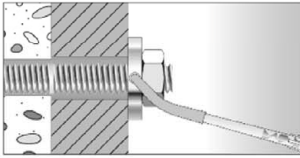
<p>10</p>		<p>Only use clean and oil-free anchor elements.</p> <p>Push the anchor rod with the setting depth mark down to the bottom of the hole, turning it slightly while doing so.</p> <p>After inserting the anchor element, excess mortar must be emerged around the anchor element.</p>
	<p>For overhead installations support the anchor rod with wedges (e. g. fischer centering wedges) or fischer overhead clips.</p>	 <p>For push through installation fill the annular gap with mortar.</p>
<p>11</p> 	<p>Wait for the specified curing time t_{cure} see Table B8.3.</p>	<p>12</p>  <p>Mounting the fixture $max T_{inst}$ see Table B3.1.</p>
<p>Option</p>		<p>After the minimum curing time is reached, the gap between anchor and fixture (annular clearance) may be filled with mortar via the fischer filling disc. Compressive strength ≥ 50 N/mm² (e.g. fischer injection mortars FIS EB II, FIS SB, FIS V Plus, FIS EM Plus).</p> <p>ATTENTION:</p> <p>Using fischer filling disk reduces t_{fix} (usable length of the anchor).</p>

fischer injection system FIS EB II



Intended use
Installation instructions part 2

Annex B 10

Appendix 17 / 34

Installation instructions part 3

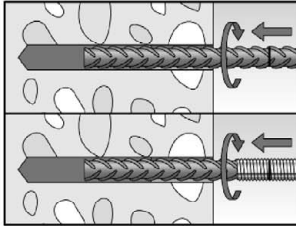
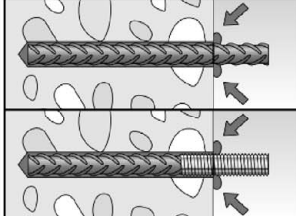
Installation Rebars and fischer FRA

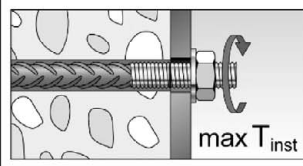
10		<p>Only use clean and oil-free rebars or fischer FRA. Push the rebar or the fischer FRA with the setting depth mark into the filled hole up to the setting depth mark.</p> <p>Recommendation: Rotation back and forth of the rebar or the fischer FRA makes pushing easy.</p>	
		<p>When the setting depth mark is reached, excess mortar must be emerged from the mouth of the drill hole.</p>	
11	 <p>Wait for the specified curing time t_{cure} see Table B8.3</p>	12	 <p>Mounting the fixture $max T_{inst}$ see Table B5.1</p>

fischer injection system FIS EB II

Intended use
Installation instructions part 3

Annex B 11
Appendix 18 / 34

Table C1.1: Characteristic resistance to steel failure under tension and shear loading of Anchor rods and Threaded rods

Anchor rod / Threaded rod		M8	M10	M12	M16	M20	M24	M27	M30			
Characteristic resistance to steel failure under tension loading ³⁾												
Characteristic resistance $N_{Rk,s}$	Steel zinc plated	Property class	4.8	14,6 (13,2)	23,2 (21,4)	33,7	62,8	98,0	141,2	183,6	224,4	
			5.8	18,3 (16,6)	29,0 (26,8)	42,1	78,5	122,5	176,5	229,5	280,5	
			8.8	29,2 (26,5)	46,4 (42,8)	67,4	125,6	196,0	282,4	367,2	448,8	
	Stainless steel R and high corrosion resistant steel HCR		50	18,3	29,0	42,1	78,5	122,5	176,5	229,5	280,5	
			70	25,6	40,6	59,0	109,9	171,5	247,1	321,3	392,7	
			80	29,2	46,4	67,4	125,6	196,0	282,4	367,2	448,8	
Partial factors ¹⁾												
Partial factor γ_{Ms}	Steel zinc plated	Property class	[-]	1,50								
				1,50								
				1,50								
	Stainless steel R and high corrosion resistant steel HCR			50	2,86							
				70	1,87 / fischer HCR: 1,50							
				80	1,60							
Characteristic resistance to steel failure under shear loading ³⁾												
without lever arm												
Characteristic resistance $V_{Rk,s}^0$	Steel zinc plated	Property class	[kN]	4.8	8,7 (7,9)	13,9 (12,8)	20,2	37,6	58,8	84,7	110,1	134,6
				5.8	10,9 (9,9)	17,4 (16,0)	25,2	47,1	73,5	105,9	137,7	168,3
				8.8	14,6 (13,2)	23,2 (21,4)	33,7	62,8	98,0	141,2	183,6	224,4
	Stainless steel R and high corrosion resistant steel HCR			50	9,1	14,5	21,0	39,2	61,2	88,2	114,7	140,2
				70	12,8	20,3	29,5	54,9	85,7	123,5	160,6	196,3
				80	14,6	23,2	33,7	62,8	98,0	141,2	183,6	224,4
Ductility factor	k_7	[-]	1,0									
with lever arm												
Characteristic resistance $M_{Rk,s}^0$	Steel zinc plated	Property class	[Nm]	4.8	14,9 (12,9)	29,9 (26,5)	52,3	132,9	259,6	448,8	665,7	899,5
				5.8	18,7 (16,1)	37,3 (33,2)	65,4	166,2	324,6	561,0	832,2	1124,4
				8.8	29,9 (25,9)	59,8 (53,1)	104,6	265,9	519,3	897,6	1331,5	1799,0
	Stainless steel R and high corrosion resistant steel HCR			50	18,7	37,3	65,4	166,2	324,6	561,0	832,2	1124,4
				70	26,2	52,3	91,5	232,6	454,4	785,4	1165	1574,1
				80	29,9	59,8	104,6	265,9	519,3	897,6	1331,5	1799,0
Partial factors ¹⁾												
Partial factor γ_{Ms}	Steel zinc plated	Property class	[-]	1,25								
				1,25								
				1,25								
	Stainless steel R and high corrosion resistant steel HCR			50	2,38							
				70	1,56 / fischer HCR: 1,25 ²⁾							
				80	1,33							

¹⁾ In absence of other national regulations.

²⁾ Only admissible for high corrosion resistant steel HCR, with $f_{yk}/f_{uk} \leq 0,8$ and $f_{uk} \leq 800 \text{ N/mm}^2$ (e.g. anchor rods).

³⁾ Values in brackets are valid for undersized threaded rods with smaller stress area A_s for hot dip galvanized threaded rods according to EN ISO 10684:2004+AC:2009.

fischer injection system FIS EB II

Performance

Characteristic resistance to steel failure under tension and shear loading of Anchor rods and Threaded rods

Annex C 1

Appendix 19 / 34

Table C2.1: Characteristic resistance to steel failure under tension and shear loading of Rebars

Nominal diameter of the rebar	ϕ	8	10	12	14	16	20	25	26	28	30	32
Characteristic resistance to steel failure under tension loading												
Characteristic resistance	$N_{Rk,s}$	[kN]	$A_s \cdot f_{uk}^{2)}$									
Characteristic resistance to steel failure under shear loading												
Without lever arm												
Characteristic resistance	$V^0_{Rk,s}$	[kN]	$k_6^{1)} \cdot A_s \cdot f_{uk}^{2)}$									
Ductility factor	k_7	[-]	1,0									
With lever arm												
Characteristic resistance	$M^0_{Rk,s}$	[Nm]	$1,2 \cdot W_{el} \cdot f_{uk}^{2)}$									

- 1) In accordance with EN 1992-4:2018 section 7.2.2.3.1
 $k_6 = 0,6$ for fasteners made of carbon steel with $f_{uk} \leq 500 \text{ N/mm}^2$
 $= 0,5$ for fasteners made of carbon steel with $500 < f_{uk} \leq 1000 \text{ N/mm}^2$
 $= 0,5$ for fasteners made of stainless steel
- 2) f_{uk} respectively shall be taken from the specifications of the rebar.

Table C2.2: Characteristic resistance to steel failure under tension and shear loading of fischer FRA

fischer FRA		M12	M16	M20	M24	
Characteristic resistance to steel failure under tension loading						
Characteristic resistance	$N_{Rk,s}$	[kN]	62,1	110,5	172,7	263,0
Partial factor¹⁾						
Partial factor	γ_{Ms}	[-]	1,4			
Characteristic resistance to steel failure under shear loading						
Without lever arm						
Characteristic resistance	$V^0_{Rk,s}$	[kN]	33,7	62,8	98,0	141,2
Ductility factor	k_7	[-]	1,0			
With lever arm						
Characteristic resistance	$M^0_{Rk,s}$	[Nm]	104,8	266,3	519,2	898,0
Partial factor¹⁾						
Partial factor	γ_{Ms}	[-]	1,25			

1) In absence of other national regulations.

Table C3.1: Characteristic resistance to concrete failure under tension and shear loading														
Size			All sizes											
Tension loading														
Installation factor		γ_{inst}	[-]		See annex C 4 to C 6									
Factors for the compressive strength of concrete > C20/25														
			Uncracked concrete					Cracked concrete						
Increasing factor ψ_{fc} for cracked or uncracked concrete $\tau_{RK}(X,Y) = \psi_{fc} \cdot \tau_{RK}(C20/25)$	C25/30		[-]	1,05					1,02					
	C30/37			1,09					1,05					
	C35/45			1,12					1,06					
	C40/50			1,16					1,08					
	C45/55			1,19					1,09					
	C50/60			1,21					1,11					
Splitting failure														
Edge distance	$h / h_{ef} \geq 2,0$		$C_{cr,sp}$	[mm]	1,0 h_{ef}									
	$2,0 > h / h_{ef} > 1,3$				4,6 h_{ef} - 1,8 h									
	$h / h_{ef} \leq 1,3$				2,26 h_{ef}									
Spacing		$S_{cr,sp}$	2 $C_{cr,sp}$											
Concrete cone failure														
Uncracked concrete		$k_{ucr,N}$	[-]	11,0										
Cracked concrete		$k_{cr,N}$		7,7										
Edge distance		$C_{cr,N}$	[mm]	1,5 h_{ef}										
Spacing		$S_{cr,N}$		2 $C_{cr,N}$										
Factors for sustained tension loading														
Temperature range			[-]	24 °C / 43 °C			43 °C / 60 °C			50 °C / 72 °C				
Factor		ψ_{sus}^0	[-]	0,66			0,61			0,60				
Shear loading														
Installation factor		γ_{inst}	[-]		1,0									
Concrete pry-out failure														
Factor for pry-out failure		k_8	[-]		2,0									
Concrete edge failure														
Effective length of fastener for shear loading		l_f	[mm]	for $d_{nom} \leq 24$ mm: min (h_{ef} ; 12 d_{nom}) for $d_{nom} > 24$ mm: min (h_{ef} ; 8 d_{nom} ; 300 mm)										
Effective diameter of the fastener d_{nom}														
Size			M8	M10	M12	M16	M20	M24	M27	M30				
Anchor rods and Threaded rods		d_{nom}	[mm]	8	10	12	16	20	24	27	30			
fischer FRA		d_{nom}		- ¹⁾	- ¹⁾	12	16	20	25	- ¹⁾	- ¹⁾			
Size (nominal diameter of the rebar)			ϕ	8	10	12	14	16	20	25	26	28	30	32
Rebar		d_{nom}	[mm]	8	10	12	14	16	20	25	26	28	30	32
1) Anchor type not part of the assessment														
fischer injection system FIS EB II										Annex C 3 Appendix 21 / 34				
Performance Characteristic resistance to concrete failure under tension / shear loading														

Table C4.1: Characteristic resistance to combined pull-out and concrete failure for Anchor rods and Threaded rods in hammer drilled holes; uncracked or cracked concrete

Anchor rod / Threaded rod		M8	M10	M12	M16	M20	M24	M27	M30			
Combined pullout and concrete cone failure												
Calculation diameter	d	[mm]	8	10	12	16	20	24	27	30		
Uncracked concrete												
Characteristic bond resistance in uncracked concrete C20/25												
<u>Hammer-drilling with standard drill bit (dry or wet concrete)</u>												
Tem- perature range	I: 24 °C / 43 °C		$\tau_{RK,ucr}$	[N/mm ²]	14,0	14,0	14,0	14,0	14,0	13,0	12,0	12,0
	II: 43 °C / 60 °C				14,0	13,0	13,0	12,0	11,0	10,0	8,5	8,5
	III: 50 °C / 72 °C				9,0	9,0	9,0	9,0	9,0	8,5	8,0	7,5
<u>Hammer-drilling with standard drill bit (water filled hole)</u>												
Tem- perature range	I: 24 °C / 43 °C		$\tau_{RK,ucr}$	[N/mm ²]	14,0	14,0	14,0	14,0	14,0	12,0	12,0	12,0
	II: 43 °C / 60 °C				12,0	11,0	11,0	10,0	9,5	8,5	8,5	8,5
	III: 50 °C / 72 °C				9,0	9,0	9,0	8,5	8,0	7,5	7,0	6,5
Installation factors												
Dry or wet concrete		γ_{inst}	[-]	1,2								
Water filled hole				1,4								
Cracked concrete												
Characteristic bond resistance in cracked concrete C20/25												
<u>Hammer-drilling with standard drill bit (dry or wet concrete)</u>												
Tem- perature range	I: 24 °C / 43 °C		$\tau_{RK,cr}$	[N/mm ²]	7,0	7,0	7,0	6,5	6,0	6,0	5,5	5,5
	II: 43 °C / 60 °C				6,5	6,5	6,5	6,0	6,0	6,0	5,5	5,5
	III: 50 °C / 72 °C				6,0	6,0	6,0	5,5	5,5	5,5	5,0	5,0
<u>Hammer-drilling with standard drill bit (water filled hole)</u>												
Tem- perature range	I: 24 °C / 43 °C		$\tau_{RK,cr}$	[N/mm ²]	7,0	7,0	7,0	6,5	6,0	6,0	5,5	5,5
	II: 43 °C / 60 °C				5,5	5,5	5,5	5,0	4,5	4,5	4,0	4,0
	III: 50 °C / 72 °C				5,5	5,5	5,5	5,0	4,0	4,0	4,0	4,0
Installation factors												
Dry or wet concrete		γ_{inst}	[-]	1,2								
Water filled hole				1,4								

fischer injection system FIS EB II

Performance

Characteristic resistance to combined pull-out and concrete failure for Anchor rod and Threaded rods

Annex C 4

Appendix 22 / 34

Table C5.1: Characteristic resistance to combined pull-out and concrete failure for Rebars in hammer drilled holes; uncracked or cracked concrete

Rebars		ϕ	8	10	12	14	16	20	25	26	28	30	32		
Combined pullout and concrete cone failure															
Calculation diameter		d	[mm]	8	10	12	14	16	20	25	26	28	30	32	
Uncracked concrete															
Characteristic bond resistance in uncracked concrete C20/25															
<u>Hammer-drilling with standard drill bit (dry or wet concrete)</u>															
Tem- perature range	I: 24 °C / 43 °C		$\tau_{RK,ucr}$	[N/mm ²]	14,0	14,0	14,0	13,0	13,0	12,0	11,0	11,0	11,0	11,0	
	II: 43 °C / 60 °C				14,0	13,0	13,0	12,0	11,0	10,0	10,0	9,0	8,5	8,0	8,0
	III: 50 °C / 72 °C				9,0	9,0	9,0	9,0	9,0	9,0	8,5	8,5	8,0	8,0	7,5
<u>Hammer-drilling with standard drill bit (water filled hole)</u>															
Tem- perature range	I: 24 °C / 43 °C		$\tau_{RK,ucr}$	[N/mm ²]	14,0	14,0	14,0	12,0	12,0	12,0	11,0	11,0	11,0	11,0	
	II: 43 °C / 60 °C				11,0	11,0	10,0	9,5	9,5	9,0	8,5	8,5	8,5	7,5	7,5
	III: 50 °C / 72 °C				9,0	9,0	9,0	8,5	8,0	7,5	7,0	6,5	6,5	6,0	6,0
Installation factors															
Dry or wet concrete		γ_{inst}	[-]	1,2											
Water filled hole				1,4											
Cracked concrete															
Characteristic bond resistance in cracked concrete C20/25															
<u>Hammer-drilling with standard drill bit (dry or wet concrete)</u>															
Tem- perature range	I: 24 °C / 43 °C		$\tau_{RK,cr}$	[N/mm ²]	7,0	7,0	7,0	6,5	6,5	6,0	6,0	5,5	5,5	5,5	
	II: 43 °C / 60 °C				6,5	6,5	6,5	6,0	6,0	6,0	5,5	5,5	5,5	5,0	5,0
	III: 50 °C / 72 °C				6,0	6,0	6,0	6,0	5,5	5,5	5,5	5,0	5,0	5,0	4,5
<u>Hammer-drilling with standard drill bit (water filled hole)</u>															
Tem- perature range	I: 24 °C / 43 °C		$\tau_{RK,cr}$	[N/mm ²]	7,0	7,0	7,0	7,0	6,5	6,0	6,0	5,5	5,5	5,5	
	II: 43 °C / 60 °C				5,5	5,5	5,5	5,0	5,0	4,5	4,0	4,0	4,0	4,0	3,5
	III: 50 °C / 72 °C				5,5	5,5	5,5	5,0	5,0	4,0	4,0	4,0	4,0	4,0	3,5
Installation factors															
Dry or wet concrete		γ_{inst}	[-]	1,2											
Water filled hole				1,4											
fischer injection system FIS EB II															
Performance Characteristic resistance to combined pull-out and concrete failure for Rebars															
Annex C 5 Appendix 23 / 34															

Table C6.1: Characteristic resistance for combined pull-out and concrete failure for fischer FRA in hammer drilled holes; uncracked or cracked concrete

fischer FRA		M12	M16	M20	M24	
Combined pullout and concrete cone failure						
Calculation diameter	d [mm]	12	16	20	25	
Uncracked concrete						
Characteristic bond resistance in uncracked concrete C20/25						
<u>Hammer-drilling with standard drill bit (dry or wet concrete)</u>						
Temperature range	I: 24 °C / 43 °C	$\tau_{RK,ucr}$ [N/mm ²]	14,0	13,0	12,0	11,0
	II: 43 °C / 60 °C		13,0	11,0	10,0	10,0
	III: 50 °C / 72 °C		9,0	9,0	9,0	8,5
<u>Hammer-drilling with standard drill bit (water filled hole)</u>						
Temperature range	I: 24 °C / 43 °C	$\tau_{RK,ucr}$ [N/mm ²]	14,0	12,0	12,0	11,0
	II: 43 °C / 60 °C		10,0	9,5	9,0	8,5
	III: 50 °C / 72 °C		9,0	8,0	7,5	7,0
Installation factors						
Dry or wet concrete	γ_{inst} [-]	[-]	1,2			
Water filled hole			1,4			
Cracked concrete						
Characteristic bond resistance in cracked concrete C20/25						
<u>Hammer-drilling with standard drill bit (dry or wet concrete)</u>						
Temperature range	I: 24 °C / 43 °C	$\tau_{RK,cr}$ [N/mm ²]	7,0	6,5	6,0	6,0
	II: 43 °C / 60 °C		6,5	6,0	6,0	5,5
	III: 50 °C / 72 °C		6,0	5,5	5,5	5,5
<u>Hammer-drilling with standard drill bit (water filled hole)</u>						
Temperature range	I: 24 °C / 43 °C	$\tau_{RK,cr}$ [N/mm ²]	7,0	6,5	6,0	6,0
	II: 43 °C / 60 °C		5,5	5,0	4,5	4,0
	III: 50 °C / 72 °C		5,5	5,0	4,0	4,0
Installation factors						
Dry or wet concrete	γ_{inst} [-]	[-]	1,2			
Water filled hole			1,4			

fischer injection system FIS EB II

Performance

Characteristic resistance for combined pull-out and concrete failure for fischer FRA

Annex C 6

Appendix 24 / 34

Table C7.1: Displacements for Anchor rods and Threaded rods									
Anchor rod	M8	M10	M12	M16	M20	M24	M27	M30	
Displacement-Factors for tension loading¹⁾									
Uncracked or cracked concrete; Temperature range I, II, III									
δ_{N0} -Factor	[mm/(N/mm ²)]	0,08	0,08	0,09	0,10	0,11	0,12	0,12	0,13
$\delta_{N\infty}$ -Factor		0,11	0,12	0,13	0,15	0,16	0,17	0,18	0,19
Displacement-Factors for shear loading²⁾									
Uncracked or cracked concrete; Temperature range I, II, III									
δ_{V0} -Factor	[mm/kN]	0,19	0,15	0,13	0,10	0,08	0,07	0,06	0,05
$\delta_{V\infty}$ -Factor		0,28	0,22	0,19	0,14	0,11	0,10	0,09	0,08
1) Calculation of effective displacement: $\delta_{N0} = \delta_{N0}\text{-Factor} \cdot \tau$ $\delta_{N\infty} = \delta_{N\infty}\text{-Factor} \cdot \tau$ $\tau =$ acting bond strength under tension loading					2) Calculation of effective displacement: $\delta_{V0} = \delta_{V0}\text{-Factor} \cdot V$ $\delta_{V\infty} = \delta_{V\infty}\text{-Factor} \cdot V$ $V =$ acting shear loading				

Table C7.2: Displacements for Rebars and fischer FRA												
Nominal diameter of the rebar ϕ	8	10	12	14	16	20	25	26	28	30	32	
fischer FRA	- ¹⁾	- ¹⁾	M12	- ¹⁾	M16	M20	M24	- ¹⁾	- ¹⁾	- ¹⁾	- ¹⁾	
Displacement-Factors for tension loading²⁾												
Uncracked or cracked concrete; Temperature range I, II, III												
δ_{N0} -Factor	[mm/(N/mm ²)]	0,08	0,08	0,09	0,10	0,10	0,11	0,12	0,12	0,13	0,13	0,13
$\delta_{N\infty}$ -Factor		0,11	0,12	0,13	0,14	0,15	0,16	0,18	0,18	0,19	0,19	0,20
Displacement-Factors for shear loading³⁾												
Uncracked or cracked concrete; Temperature range I, II, III												
δ_{V0} -Factor	[mm/kN]	0,19	0,15	0,13	0,11	0,10	0,08	0,06	0,06	0,06	0,05	0,05
$\delta_{V\infty}$ -Factor		0,28	0,22	0,19	0,16	0,14	0,11	0,09	0,09	0,08	0,08	0,07
1) Anchor type not part of the assessment 2) Calculation of effective displacement: $\delta_{N0} = \delta_{N0}\text{-Factor} \cdot \tau$ $\delta_{N\infty} = \delta_{N\infty}\text{-Factor} \cdot \tau$ $\tau =$ acting bond strength under tension loading					3) Calculation of effective displacement: $\delta_{V0} = \delta_{V0}\text{-Factor} \cdot V$ $\delta_{V\infty} = \delta_{V\infty}\text{-Factor} \cdot V$ $V =$ acting shear loading							

fischer injection system FIS EB II	Annex C 7 Appendix 25 / 34
Performance Displacements for Anchor rods, Threaded rods, Rebars and fischer FRA	

Table C8.1: Characteristics resistance to steel failure under tension / shear loading of Anchor rods and Threaded rods under seismic action performance category C1 or C2

Anchor rod / Threaded rod		M12	M14	M16	M20	M22	M24	M27	M30			
Characteristic resistance to steel failure under tension loading¹⁾												
Anchor rods and Threaded rods, performance category C1												
Characteristic resistance $N_{Rk,s,C1}$	Steel zinc plated	Property class	4.8	[kN]	33,7	46,0	62,8	98,0	121,2	141,2	183,6	224,4
			5.8		42,1	57,5	78,5	122,5	151,5	176,5	229,5	280,5
	8.8	67,4	92,0		125,6	196,0	242,4	282,4	367,2	448,8		
	Stainless steel R and high corrosion resistant steel HCR	50	42,1		57,5	78,5	122,5	151,5	176,5	229,5	280,5	
		70	59,0		80,5	109,9	171,5	212,1	247,1	321,3	392,7	
		80	67,4		92,0	125,6	196,0	242,4	282,4	367,2	448,8	
Anchor rods and Threaded rods, performance category C2												
Characteristic resistance $N_{Rk,s,C2}$	Steel zinc plated	Property class	4.8	[-]	30,3	-2)	56,5	88,2	-2)	141,2	-2)	-2)
			5.8		37,9	-2)	70,6	110,2	-2)	176,5	-2)	-2)
	8.8	60,6	-2)		113,0	176,4	-2)	282,4	-2)	-2)		
	Stainless steel R and high corrosion resistant steel HCR	50	37,9		-2)	70,6	110,2	-2)	176,5	-2)	-2)	
		70	53,1		-2)	98,9	154,3	-2)	247,1	-2)	-2)	
		80	60,6		-2)	113,0	176,4	-2)	282,4	-2)	-2)	
Characteristic resistance to steel failure under shear loading without lever arm¹⁾												
Anchor rods, performance category C1												
Characteristic resistance $V_{Rk,s,C1}^0$	Steel zinc plated	Property class	4.8	[kN]	20,2	27,6	37,6	58,8	72,7	84,7	110,1	134,6
			5.8		25,2	34,5	47,1	73,5	90,9	105,9	137,7	168,3
	8.8	33,7	46,0		62,8	98,0	121,2	141,2	183,6	224,4		
	Stainless steel R and high corrosion resistant steel HCR	50	21,0		28,7	39,2	61,2	75,7	88,2	114,7	140,2	
		70	29,5		40,2	54,9	85,7	106,0	123,5	160,6	196,3	
		80	33,7		46,0	62,8	98,0	121,2	141,2	183,6	224,4	
Threaded rods, performance category C1												
Characteristic resistance $V_{Rk,s,C1}^0$	Steel zinc plated	Property class	4.8	[kN]	14,1	19,3	26,3	41,1	50,9	59,3	77,1	94,2
			5.8		17,7	24,1	32,9	51,4	63,6	74,1	96,3	117,8
	8.8	23,6	32,2		43,9	68,6	84,8	98,8	128,5	157,0		
	Stainless steel R and high corrosion resistant steel HCR	50	14,7		20,1	27,4	42,8	53,0	61,7	80,3	98,1	
		70	20,6		28,1	38,4	60,0	74,2	86,4	112,4	137,4	
		80	23,6		32,2	43,9	68,6	84,8	98,8	128,5	157,0	
Anchor rods and Threaded rods, performance category C2												
Characteristic resistance $V_{Rk,s,C2}^0$	Steel zinc plated	Property class	4.8	[-]	13,3	-2)	28,2	45,2	-2)	77,0	-2)	-2)
			5.8		16,6	-2)	35,3	56,5	-2)	96,3	-2)	-2)
	8.8	22,2	-2)		47,1	75,4	-2)	128,4	-2)	-2)		
	Stainless steel R and high corrosion resistant steel HCR	50	13,9		-2)	29,4	47,1	-2)	80,3	-2)	-2)	
		70	19,4		-2)	41,2	66,0	-2)	112,4	-2)	-2)	
		80	22,2		-2)	47,1	75,4	-2)	128,4	-2)	-2)	

1) Partial factors for performance category C1 or C2 see **table C10.1**;
for anchor rods the factor for steel ductility is 1,0

2) No performance assessed

fischer injection system FIS EB II

Performance

Characteristic resistance to steel failure for Anchor rods and Threaded rods under seismic action (performance category C1 / C2)

Annex C 8

Appendix 26 / 34

Table C9.1: Characteristic resistance to steel failure under tension / shear loading of Rebars (B500B) under seismic action performance category C1 or C2

Nominal diameter of the rebar		ϕ	12	14	16	20	25	26	28	30
Characteristic resistance to steel failure under tension loading¹⁾										
Rebar B500B acc. to DIN 488-2:2009-08, performance category C1										
Characteristic resistance	$N_{Rk,s,C1}$	[kN]	61,0	83,1	108,5	169,5	265,1	286,2	332,6	381,2
Rebar B500B acc. to DIN 488-2:2009-08, performance category C2										
Characteristic resistance	$N_{Rk,s,C2}$	[kN]	54,9	- ²⁾	97,6	152,6	- ²⁾	- ²⁾	- ²⁾	- ²⁾
Characteristic resistance to steel failure under shear loading, without lever arm¹⁾										
Rebar B500B acc. to DIN 488-2:2009-08, performance category C1										
Characteristic resistance	$V^0_{Rk,s,C1}$	[kN]	21,3	29,1	37,9	59,3	92,7	100,1	116,4	133,4
Rebar B500B acc. to DIN 488-2:2009-08, performance category C2										
Characteristic resistance	$V^0_{Rk,s,C2}$	[kN]	20,1	- ²⁾	40,7	65,2	- ²⁾	- ²⁾	- ²⁾	- ²⁾

1) Partial factors for performance category C1 or C2 see table C10.1

2) No performance assessed

Table C9.2: Characteristic resistance to steel failure under tension / shear loading of fischer FRA under seismic action performance category C1 or C2

fischer FRA			M12	M16	M20	M24
Characteristic resistance to steel failure under tension loading¹⁾						
fischer FRA, performance category C1						
Characteristic resistance	$N_{Rk,s,C1}$	[kN]	62,1	110,5	172,7	263,0
fischer FRA, performance category C2						
Characteristic resistance	$N_{Rk,s,C2}$	[kN]	55,8	99,4	155,4	- ²⁾
Characteristic resistance to steel failure under shear loading, without lever arm¹⁾						
fischer FRA, performance category C1						
Characteristic resistance	$V^0_{Rk,s,C1}$	[kN]	33,7	62,8	98,0	141,2
fischer FRA, performance category C2						
Characteristic resistance	$V^0_{Rk,s,C2}$	[kN]	22,2	47,1	75,4	- ²⁾

1) Partial factors for performance category C1 or C2 see table C10.1

2) No performance assessed

fischer injection system FIS EB II	Annex C 9 Appendix 27 / 34
Performance Characteristic resistance to steel failure under tension / shear loading of Rebars and fischer FRA under seismic action performance category C1 or C2	

Table C10.1: Partial factors for Anchor rods, Threaded rods, Rebars (B500B) and fischer FRA under seismic action performance category C1 or C2

Anchor rod / Threaded rod		M12	M16	M20	M24	M27	M30		
Nominal diameter of the rebar ϕ		12	14	16	20	25	26	28	30
fischer FRA		M12	M16	M20	M24	_3)		_3)	
Tension loading, steel failure¹⁾									
Partial factor γ_{Ms}	Steel zinc plated	4.8	[-]	1,50					
		5.8		1,50					
	Property class	8.8		1,50					
		50		2,86					
		70		1,87 / fischer HCR: 1,50					
		80		1,60					
	Rebar	B500B		1,40					
	fischer	FRA		1,40					
Shear loading, steel failure¹⁾									
Partial factor γ_{Ms}	Steel zinc plated	4.8	[-]	1,25					
		5.8		1,25					
	Property class	8.8		1,25					
		50		2,38					
		70		1,56 / fischer HCR: 1,25 ²⁾					
		80		1,33					
	Rebar	B500B		1,50					
	fischer	FRA		1,50					

1) In absence of other national regulations

2) Only admissible for high corrosion resistant steel HCR, with $f_{yk}/f_{uk} \leq 0,8$ and $f_{uk} \leq 800 \text{ N/mm}^2$ (e.g. anchor rods)

3) Anchor type not part of the assessment

fischer injection system FIS EB II

Performance

Partial factors for Anchor rods, Threaded rods, Rebars and fischer FRA under seismic action performance category C1 or C2

Annex C 10

Appendix 28 / 34

Table C11.1: Characteristics resistance for combined pull-out and concrete failure for Anchor rods and Threaded rods in hammer drilled holes under seismic action performance category C1

Anchor rod / Threaded rod		M12	M16	M20	M24	M27	M30	
Characteristic bond resistance, combined pull-out and concrete cone failure								
Hammer-drilling with standard drill bit or hollow drill bit (dry or wet concrete)								
Tem- perature range	I: 24 °C / 43 °C	$\tau_{RK,C1}$ [N/mm ²]	6,5	5,6	5,0	5,5	5,5	5,5
	II: 43 °C / 60 °C		6,5	5,6	5,0	5,5	5,5	5,5
	III: 50 °C / 72 °C		5,7	5,5	5,0	5,0	5,0	5,0
Hammer-drilling with standard drill bit or hollow drill bit (water filled hole)								
Tem- perature range	I: 24 °C / 43 °C	$\tau_{RK,C1}$ [N/mm ²]	6,5	5,0	4,7	4,7	4,7	4,7
	II: 43 °C / 60 °C		6,5	5,0	4,7	4,7	4,7	4,7
	III: 50 °C / 72 °C		5,7	5,5	5,0	5,0	5,0	5,0
Installation factors								
Tension loading								
Dry or wet concrete		γ_{inst}	[-]					1,2
Water filled hole								1,4

Table C11.2: Characteristics resistance for combined pull-out and concrete failure for Rebars and fischer FRA in hammer drilled holes under seismic action performance category C1

Nominal diameter of the rebar	ϕ	12	14	16	20	25	26	28	30	
fischer FRA		M12	- ¹⁾	M16	M20	M24	- ¹⁾	- ¹⁾	- ¹⁾	
Characteristic bond resistance, combined pull-out and concrete cone failure										
Hammer-drilling with standard drill bit or hollow drill bit (dry or wet concrete)										
Tem- perature range	I: 24 °C / 43 °C	$\tau_{RK,C1}$ [N/mm ²]	6,5	6,0	6,0	6,0	5,5	5,5	5,5	5,5
	II: 43 °C / 60 °C		6,5	6,0	6,0	6,0	5,5	5,5	5,5	5,5
	III: 50 °C / 72 °C		5,7	5,5	5,5	5,0	5,0	5,0	5,0	5,0
Hammer-drilling with standard drill bit or hollow drill bit (water filled hole)										
Tem- perature range	I: 24 °C / 43 °C	$\tau_{RK,C1}$ [N/mm ²]	6,5	6,0	5,0	4,7	4,7	4,7	4,7	4,7
	II: 43 °C / 60 °C		6,5	6,0	5,0	4,7	4,7	4,7	4,7	4,7
	III: 50 °C / 72 °C		5,7	5,5	5,5	4,7	4,7	4,7	4,7	4,7
Installation factors										
Tension loading										
Dry or wet concrete		γ_{inst}	[-]					1,2		
Water filled hole								1,4		

¹⁾ Anchor type not part of the assessment

fischer injection system FIS EB II	Annex C 11 Appendix 29 / 34
Performance Characteristics resistance under seismic action (performance category C1) for Anchor rods, Threaded rods, Rebars and fischer FRA	

Table C12.1: Characteristics resistance for combined pull-out and concrete failure for Anchor rods and Threaded rods in hammer drilled holes under seismic action performance category C2

Anchor rod / Threaded rod		M12	M16	M20	M24	
Characteristic bond resistance, combined pull-out and concrete cone failure						
Hammer-drilling with standard drill bit or hollow drill bit (dry or wet concrete)						
Temperature range	I: 24 °C / 43 °C	$\tau_{Rk,C2}$ [N/mm ²]	3,5	5,0	3,5	3,5
	II: 43 °C / 60 °C		3,5	5,0	3,5	3,5
	III: 50 °C / 72 °C		2,7	3,8	2,6	2,9
Hammer-drilling with standard drill bit or hollow drill bit (water filled hole)						
Temperature range	I: 24 °C / 43 °C	$\tau_{Rk,C2}$ [N/mm ²]	3,5	5,6	3,8	3,0
	II: 43 °C / 60 °C		3,5	5,2	3,6	3,0
	III: 50 °C / 72 °C		2,7	3,8	2,6	2,8
Installation factors						
Tension loading						
Dry or wet concrete		γ_{inst} [-]	1,2			
Water filled hole			1,4			
Displacement-Factors for tension loading¹⁾						
$\delta_{N,(DLS)-Factor}$	[mm/(N/mm ²)]	0,06	0,11	0,08	0,12	
$\delta_{N,(ULS)-Factor}$		0,13	0,14	0,09	0,18	
Displacement-Factors for shear loading²⁾						
$\delta_{V,(DLS)-Factor}$	[mm/kN]	0,18	0,10	0,07	0,06	
$\delta_{V,(ULS)-Factor}$		0,25	0,14	0,11	0,09	

1) Calculation of effective displacement:

$$\delta_{N,C2(DLS)} = \delta_{N,(DLS)-Factor} \cdot \tau$$

$$\delta_{N,C2(ULS)} = \delta_{N,(ULS)-Factor} \cdot \tau$$

τ = acting bond strength under tension loading

2) Calculation of effective displacement:

$$\delta_{V,C2(DLS)} = \delta_{V,(DLS)-Factor} \cdot V$$

$$\delta_{V,C2(ULS)} = \delta_{V,(ULS)-Factor} \cdot V$$

V = acting shear loading

fischer injection system FIS EB II

Performance

Characteristics resistance under seismic action (performance category C2) for Anchor rods, Threaded rods.

Annex C 12

Appendix 30 / 34

Table C13.1: Characteristics resistance for combined pull-out and concrete failure for Rebars and fischer FRA in hammer drilled holes under seismic action performance category C2

Nominal diameter of the rebar		ϕ	12	16	20	
fischer FRA			M12	M16	M20	
Characteristic bond resistance, combined pull-out and concrete cone failure						
Hammer-drilling with standard drill bit or hollow drill bit (dry or wet concrete)						
Tem- perature range	I: 24 °C / 43 °C	$\tau_{Rk,C2}$	[N/mm ²]	3,5	5,0	3,5
	II: 43 °C / 60 °C			3,5	5,0	3,5
	III: 50 °C / 72 °C			2,7	3,8	2,6
Hammer-drilling with standard drill bit or hollow drill bit (water filled hole)						
Tem- perature range	I: 24 °C / 43 °C	$\tau_{Rk,C2}$	[N/mm ²]	3,5	5,6	3,8
	II: 43 °C / 60 °C			3,5	5,2	3,6
	III: 50 °C / 72 °C			2,7	3,8	2,6

Installation factors					
Tension loading					
Dry or wet concrete		γ_{inst}	[-]	1,2	
Water filled hole				1,4	

Displacement-Factors for tension loading¹⁾					
$\delta_{N,(DLS)-Factor}$		[mm/(N/mm ²)]	0,06	0,11	0,08
$\delta_{N,(ULS)-Factor}$			0,13	0,14	0,09

Displacement-Factors for shear loading²⁾					
$\delta_{V,(DLS)-Factor}$		[mm/kN]	0,18	0,10	0,07
$\delta_{V,(ULS)-Factor}$			0,25	0,14	0,11

1) Calculation of effective displacement:

$$\delta_{N,C2(DLS)} = \delta_{N,(DLS)-Factor} \cdot \tau$$

$$\delta_{N,C2(ULS)} = \delta_{N,(ULS)-Factor} \cdot \tau$$

τ = acting bond strength under tension loading

2) Calculation of effective displacement:

$$\delta_{V,C2(DLS)} = \delta_{V,(DLS)-Factor} \cdot V$$

$$\delta_{V,C2(ULS)} = \delta_{V,(ULS)-Factor} \cdot V$$

V = acting shear loading

fischer injection system FIS EB II

Performance

Characteristics resistance under seismic action (performance category C2) for Rebar and fischer FRA.

Annex C 13

Table C14.1: Fire resistance to steel failure under tension and shear loading of Anchor rods and Threaded rods

Fire resistance to steel failure under tension and shear loading						
Anchor rod / Threaded rod	R30			R60		
Steel zinc plated	$N_{Rk,s,fi,30}$ [kN]	$V_{Rk,s,fi,30}$ [kN]	$M^0_{Rk,s,fi,30}$ [Nm]	$N_{Rk,s,fi,60}$ [kN]	$V_{Rk,s,fi,60}$ [kN]	$M^0_{Rk,s,fi,60}$ [Nm]
M8	0,4	0,4	0,4	0,3	0,3	0,3
M10	0,9	0,9	1,1	0,8	0,8	1,0
M12	1,7	1,7	2,6	1,3	1,3	2,0
M16	3,1	3,1	6,7	2,4	2,4	5,0
M20	4,9	4,9	13,0	3,7	3,7	9,7
M24	7,1	7,1	22,5	5,3	5,3	16,8
M27	9,2	9,2	33,3	6,9	6,9	25,0
M30	11,2	11,2	45,0	8,4	8,4	33,7
Anchor rod / Threaded rod	R90			R120		
Steel zinc plated	$N_{Rk,s,fi,90}$ [kN]	$V_{Rk,s,fi,90}$ [kN]	$M^0_{Rk,s,fi,90}$ [Nm]	$N_{Rk,s,fi,120}$ [kN]	$V_{Rk,s,fi,120}$ [kN]	$M^0_{Rk,s,fi,120}$ [Nm]
M8	0,3	0,3	0,3	0,2	0,2	0,2
M10	0,6	0,6	0,7	0,5	0,5	0,6
M12	1,1	1,1	1,7	0,8	0,8	1,3
M16	2,0	2,0	4,3	1,6	1,6	3,3
M20	3,2	3,2	8,4	2,5	2,5	6,5
M24	4,6	4,6	14,6	3,5	3,5	11,2
M27	6,0	6,0	21,6	4,6	4,6	16,6
M30	7,3	7,3	29,2	5,6	5,6	22,5
Anchor rod / Threaded rod	R30			R60		
Stainless steel R and high corrosion resistant steel HCR	$N_{Rk,s,fi,30}$ [kN]	$V_{Rk,s,fi,30}$ [kN]	$M^0_{Rk,s,fi,30}$ [Nm]	$N_{Rk,s,fi,60}$ [kN]	$V_{Rk,s,fi,60}$ [kN]	$M^0_{Rk,s,fi,60}$ [Nm]
M8	0,7	0,7	0,7	0,6	0,6	0,6
M10	1,5	1,5	1,9	1,2	1,2	1,5
M12	2,5	2,5	3,9	2,1	2,1	3,3
M16	4,7	4,7	10,0	3,9	3,9	8,3
M20	7,4	7,4	19,5	6,1	6,1	16,2
M24	10,6	10,6	33,7	8,8	8,8	28,1
M27	13,8	13,8	49,9	11,5	11,5	41,6
M30	16,8	16,8	67,5	14,0	14,0	56,2
Anchor rod / Threaded rod	R90			R120		
Stainless steel R and high corrosion resistant steel HCR	$N_{Rk,s,fi,90}$ [kN]	$V_{Rk,s,fi,90}$ [kN]	$M^0_{Rk,s,fi,90}$ [Nm]	$N_{Rk,s,fi,120}$ [kN]	$V_{Rk,s,fi,120}$ [kN]	$M^0_{Rk,s,fi,120}$ [Nm]
M8	0,4	0,4	0,4	0,4	0,4	0,4
M10	0,9	0,9	1,2	0,8	0,8	1,0
M12	1,7	1,7	2,6	1,3	1,3	2,1
M16	3,1	3,1	6,7	2,5	2,5	5,3
M20	4,9	4,9	13,0	3,9	3,9	10,4
M24	7,1	7,1	22,5	5,6	5,6	18,0
M27	9,2	9,2	33,3	7,3	7,3	26,6
M30	11,2	11,2	45,0	9,0	9,0	36,0

fischer injection system FIS EB II

Performance

Fire resistance to steel failure under tension and shear loading of Anchor rods and Threaded rods

Annex C 14

Appendix 32 / 34

Table C15.1: Fire resistance to steel failure under tension and shear loading of Rebars and fischer FRA

Fire resistance to steel failure under tension and shear loading						
Rebar	R30			R60		
Bars and de-coiled rods	$N_{Rk,s,fi,30}$ [kN]	$V_{Rk,s,fi,30}$ [kN]	$M^0_{Rk,s,fi,30}$ [Nm]	$N_{Rk,s,fi,60}$ [kN]	$V_{Rk,s,fi,60}$ [kN]	$M^0_{Rk,s,fi,60}$ [Nm]
φ 8	0,5	0,5	0,6	0,5	0,5	0,5
φ 10	1,2	1,2	1,8	1,0	1,0	1,5
φ 12	2,3	2,3	4,1	1,7	1,7	3,0
φ 14	3,1	3,1	6,5	2,3	2,3	4,9
φ 16	4,0	4,0	9,6	3,0	3,0	7,2
φ 20	6,3	6,3	18,8	4,7	4,7	14,1
φ 25	9,8	9,8	36,8	7,4	7,4	27,6
φ 26	10,6	10,6	41,4	8,0	8,0	31,1
φ 28	12,3	12,3	51,8	9,2	9,2	38,8
φ 30	14,1	14,1	63,6	10,6	10,6	47,7
φ 32	16,1	16,1	77,2	12,1	12,1	57,9
Rebar	R90			R120		
Bars and de-coiled rods	$N_{Rk,s,fi,90}$ [kN]	$V_{Rk,s,fi,90}$ [kN]	$M^0_{Rk,s,fi,90}$ [Nm]	$N_{Rk,s,fi,120}$ [kN]	$V_{Rk,s,fi,120}$ [kN]	$M^0_{Rk,s,fi,120}$ [Nm]
φ 8	0,4	0,4	0,4	0,3	0,3	0,3
φ 10	0,8	0,8	1,2	0,6	0,6	0,9
φ 12	1,5	1,5	2,6	1,1	1,1	2,0
φ 14	2,0	2,0	4,2	1,5	1,5	3,2
φ 16	2,6	2,6	6,3	2,0	2,0	4,8
φ 20	4,1	4,1	12,2	3,1	3,1	9,4
φ 25	6,4	6,4	23,9	4,9	4,9	18,4
φ 26	6,9	6,9	26,9	5,3	5,3	20,7
φ 28	8,0	8,0	33,6	6,2	6,2	25,9
φ 30	9,2	9,2	41,4	7,1	7,1	31,8
φ 32	10,5	10,5	50,2	8,0	8,0	38,6
fischer FRA	R30			R60		
Stainless steel R and high corrosion resistant steel HCR	$N_{Rk,s,fi,30}$ [kN]	$V_{Rk,s,fi,30}$ [kN]	$M^0_{Rk,s,fi,30}$ [Nm]	$N_{Rk,s,fi,60}$ [kN]	$V_{Rk,s,fi,60}$ [kN]	$M^0_{Rk,s,fi,60}$ [Nm]
M12	2,5	2,5	3,9	2,1	2,1	3,3
M16	4,7	4,7	10,0	3,9	3,9	8,3
M20	7,4	7,4	19,5	6,1	6,1	16,2
M24	10,6	10,6	33,7	8,8	8,8	28,1
fischer FRA	R90			R120		
Stainless steel R and high corrosion resistant steel HCR	$N_{Rk,s,fi,90}$ [kN]	$V_{Rk,s,fi,90}$ [kN]	$M^0_{Rk,s,fi,90}$ [Nm]	$N_{Rk,s,fi,120}$ [kN]	$V_{Rk,s,fi,120}$ [kN]	$M^0_{Rk,s,fi,120}$ [Nm]
M12	1,7	1,7	2,6	1,3	1,3	2,1
M16	3,1	3,1	6,7	2,5	2,5	5,3
M20	4,9	4,9	13,0	3,9	3,9	10,4
M24	7,1	7,1	22,5	5,6	5,6	18,0

fischer injection system FIS EB II	Annex C 15 Appendix 33 / 34
Performance Fire resistance to steel failure under tension and shear loading of Rebars an fischer FRA	

Characteristic bond resistance for cracked concrete under fire conditions for Anchor rods, Threaded rods, Rebars and fischer FRA for hammer drilled holes

The characteristic bond resistance for cracked concrete under fire conditions for a given temperature

$\tau_{RK,fi}(\theta)$ has to be calculated by the following equation:

$$\tau_{RK,fi}(\theta) = k_{fi,p}(\theta) \cdot \tau_{RK,cr,C20/25}$$

θ	=	Temperature in °C in the mortar layer		
$\tau_{RK,fi}(\theta)$	=	Characteristic bond resistance for cracked and uncracked concrete under fire exposure for a given temperature in N/mm ² for concrete classes C20/25 to C50/60		
$k_{fi,p}(\theta)$	=	Reduction factor under fire conditions		
$\tau_{RK,cr,C20/25}$	=	Characteristic bond resistance for cracked concrete C20/25 in N/mm ² , given in Table C4.1, Table C5.1 or Table C6.1, respectively		
Anchor rods and Threaded rods	If: $\theta > 20\text{ °C}$ If: $\theta > \theta_{max} = 373\text{ °C}$	$k_{fi,p}(\theta) = 61,573 \cdot \theta^{-1,400} \geq 1,0$ $k_{fi,p}(\theta) = 0$		see Figure C16.1
Rebars and fischer FRA	If: $\theta > 23\text{ °C}$ If: $\theta > \theta_{max} = 236\text{ °C}$	$k_{fi,p}(\theta) = 252,678 \cdot \theta^{-1,777} \geq 1,0$ $k_{fi,p}(\theta) = 0$		see Figure C16.2

Figure C16.1: Graph of reduction factor $k_{fi,p}(\theta)$ for anchor rods threaded rods

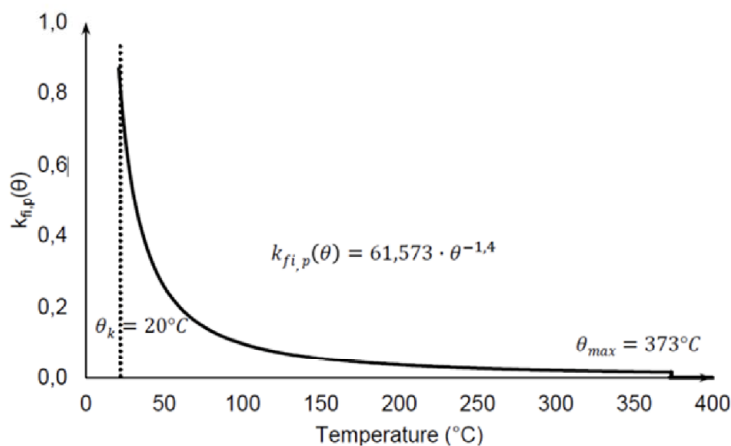
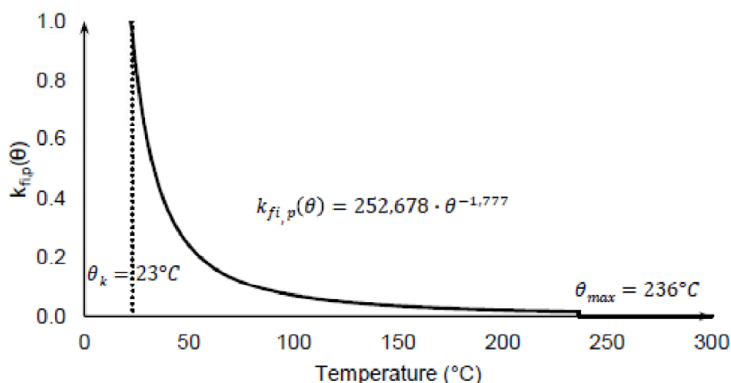

Figure C16.2: Graph of reduction factor $k_{fi,p}(\theta)$ for rebars and fischer FRA



fischer injection system FIS EB II

Performance
Characteristic bond resistance under fire conditions

Annex C 16

Appendix 34 / 34