

DECLARACIÓN DE PRESTACIONES

DoP 0256

para fischer FIF - PN (Anclajes de plástico para el uso en hormigón y mampostería)

ES

- | | | |
|--|--|-----------------|
| 1. <u>Código de identificación única del producto tipo:</u> | DoP 0256 | |
| 2. <u>Usos previstos:</u> | Anclaje de plástico clavado para la fijación de sistemas compuestos de aislamiento térmico exterior (ETICS) con revoque en hormigón y mampostería, véase el apéndice, especialmente los anexos B1-B3. | |
| 3. <u>Fabricante:</u> | fischerwerke GmbH & Co. KG, Klaus-Fischer-Str. 1, 72178 Waldachtal, Alemania | |
| 4. <u>Representante autorizado:</u> | - | |
| 5. <u>Sistemas de evaluación y verificación de la constancia de las prestaciones (EVCP):</u> | 2+ | |
| 6. <u>Documento de evaluación europeo:</u> | EAD 330196-01-0604 | |
| Evaluación técnica europea: | ETA-18/0253; 2018-05-29 | |
| Organismo de evaluación técnica: | DIBt- Deutsches Institut für Bautechnik | |
| Organismos notificados: | 2873 TU Darmstadt | |
| 7. <u>Prestaciones declaradas:</u> | | |
| Seguridad en uso (BWR 4) | | |
| Capacidad de carga característica: | Resistencia característica bajo carga de tensión: | Anexo C1 |
| | Distancia mínima al borde: | Anexo B2 |
| | Espacio mínimo: | Anexo B2 |
| Desplazamientos: | Carga de tensión con factor parcial: | Anexo C1 |
| | Desplazamientos: | Anexo C1 |
| Rigidez de la placa: | Diámetro de la placa de anclaje: | Anexo C1 |
| | Resistencia a la carga de la placa de anclaje: | Anexo C1 |
| | Rigidez de la placa: | Anexo C1 |
| Economía de energía y retención de calor (BWR 6) | | |
| Transmitancia térmica: | Transmitancia térmica puntual de un anclaje: | Anexo C1 |
| | Espesor de la capa aislante del ETICS: | Anexo C1 |
| 8. <u>Documentación técnica adecuada o documentación técnica específica:</u> | - | |

Las prestaciones del producto identificado anteriormente son conformes con el conjunto de prestaciones declaradas. La presente declaración de prestaciones se emite, de conformidad con el Reglamento (UE) no 305/2011, bajo la sola responsabilidad del fabricante arriba identificado.

Firmado por y en nombre del fabricante por:

Dr. Oliver Geibig, Director General Unidades de Negocio e Ingeniería
Tumlingen, 2021-01-15

Jürgen Grün, Director General de Química y Calidad

Esta DdR se ha preparado en distintos idiomas. En caso de que haya alguna controversia sobre la interpretación prevalecerá siempre la versión inglesa.

El Apéndice incluye información voluntaria y complementaria en idioma inglés que excede los requisitos legales (de idioma neutral).

Specific Part

1 Technical description of the product

The fischer FIF - PN consists of a plastic sleeve made of polypropylene (virgin material), a plate and an accompanying specific nail made of glass fibre reinforced polyamide (virgin material).
The anchor may in addition be combined with the slip-on-plate DT 90, DT 110 and DT 140.
The product description is given in Annex A.

2 Specification of the intended use in accordance with the applicable European Assessment Document

The performances given in Section 3 are only valid if the anchor is used in compliance with the specifications and conditions given in Annex B.

The verification and assessment methods on which this European Technical Assessment is based lead to the assumption of a working life of the anchor of at least 25 years. The indications given on the working life cannot be interpreted as a guarantee given by the producer, but are to be regarded only as a means for choosing the right products in relation to the expected economically reasonable working life of the works.

3 Performance of the product and references to the methods used for its assessment

3.1 Safety and accessibility in use (BWR 4)

Essential characteristic	Performance
Characteristic tension resistance	See Annex C 1
Edge distances and spacing	See Annex B 2
Plate stiffness	See Annex C 1
Displacements	See Annex C 1

3.2 Energy economy and heat retention (BWR 6)

Essential characteristic	Performance
Point thermal transmittance	See Annex C 1

4 Assessment and verification of constancy of performance (AVCP) system applied, with reference to its legal base

In accordance with EAD No. 330196-01-0604, the applicable European legal act is: [97/463/EC].

The system to be applied is: 2+

Installed anchor: FIF-PN

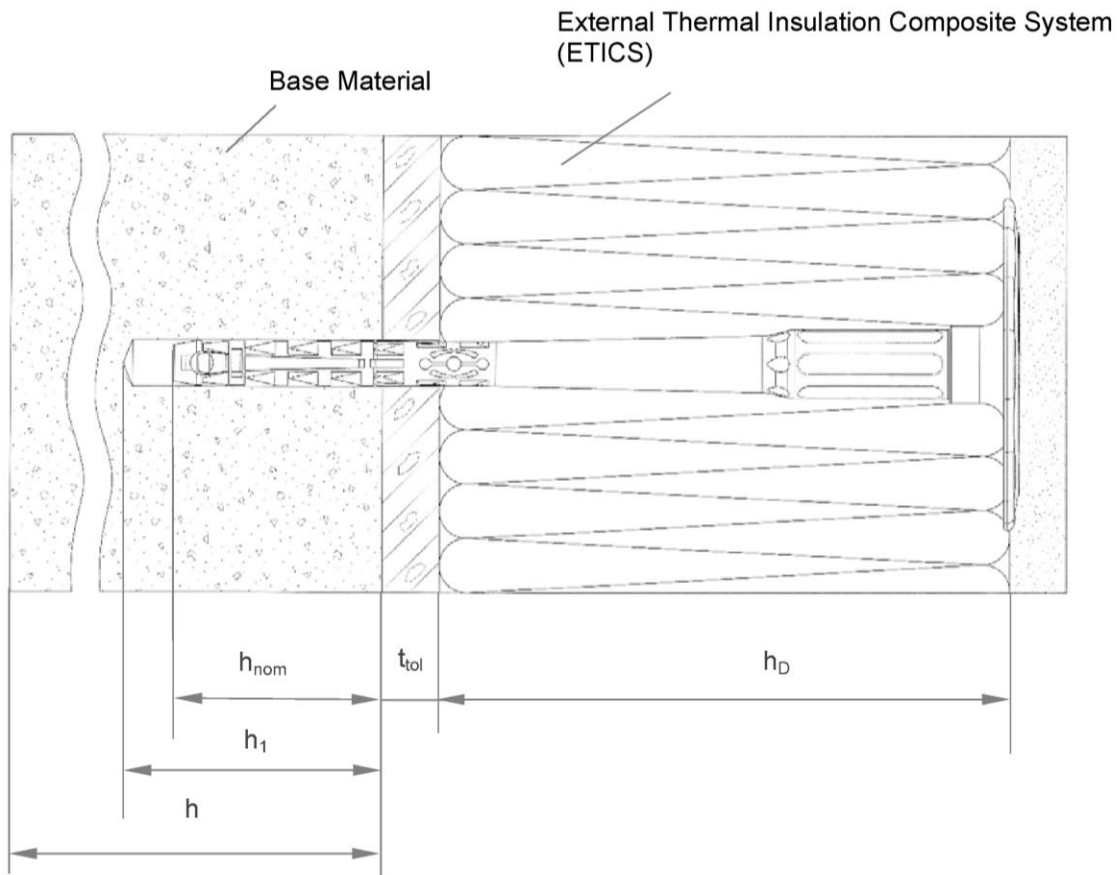

Legend

- h_{nom} = Overall plastic anchor embedment depth in the base material
- h_1 = Depth of drilled hole to deepest point
- h = Thickness of member (wall)
- h_D = Thickness of insulation material
- t_{tol} = Thickness of equalizing layer or non-load bearing coating

Figures not to scale

fischer FIF-PN

Product description
Installed anchor

Annex A 1

Appendix 2 / 8

Single parts : FIF-PN

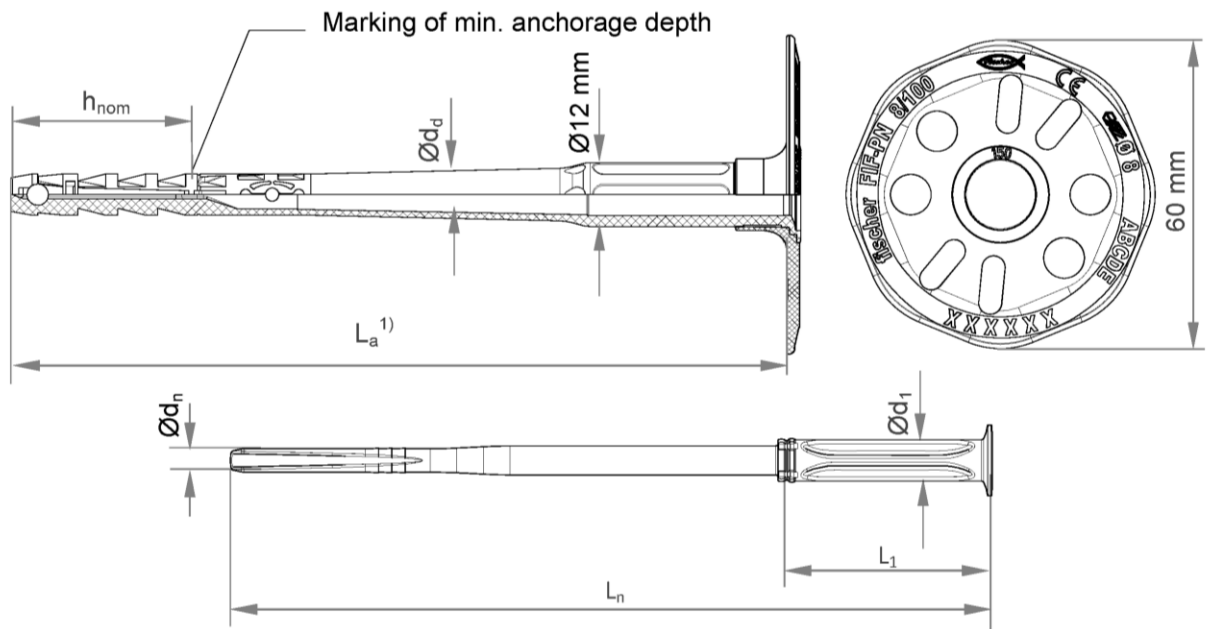

1) Various length of the anchors are possible:

$$L_a = L_n \text{ (length of accompanying specific nail) } + 5 \text{ mm}$$





Determination of maximum thickness of insulation: $h_D = L_a - h_{nom} - t_{tol}$

e.g. FIF-PN 8x150:

$$L_a = 148 \text{ mm, } h_{nom} = 35 \text{ mm, } t_{tol} = 10 \text{ mm}$$

$$h_D = 148 - 35 - 10 \approx 100 \text{ mm}$$

Table A2.1: Marking

Anchor Type	FIF-PN
Anchor plate diameter	Ø 60 mm
Works symbol	 or  or blank
Size of anchor	Ø 8 mm
Length of anchor	L_a
Example	fischer (optional) FIF-PN  or  or blank CE (optional)  Ø 8 (optional) ABCDE (optional) XXXXXX= additional marking possible

Figures not to scale

fischer FIF-PN

Product description
Anchor type and Marking

Annex A 2

Appendix 3 / 8

Table A3.1: Dimensions

Anchor Type	Anchor Sleeve				Accompanying specific nail		
	$\varnothing d_d$	h_{nom}	$L_{a,min}$	$L_{a,max}$	$\varnothing d_n$	L_1	$\varnothing d_1$
	[mm]						
FIF-PN	8	35	110	230	4,4	40	8

Table A3.2: Materials

Designation	Material
Anchor sleeve	PP (virgin material), colour: grey
Anchor plate	PA6 (virgin material) GF; colour: grey
Special nail	PA6 GF (virgin material), colour: nature

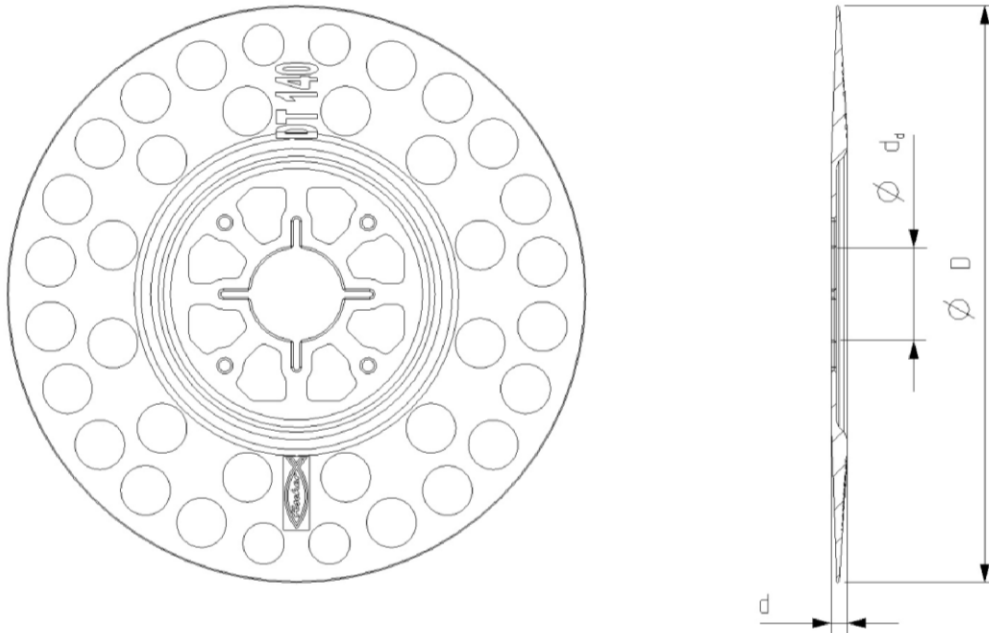
Drawing of the slip-on plate**Table A3.3: Slip-on plate, diameters and material**

Slip-on plate	$\varnothing D$	$\varnothing d_d$	d	Material
	[mm]			
DT 90 / 110 / 140	90 / 110 / 140	22,5	3,9	PA6 GF

Figures not to scale

fischer FIF-PN

Product description

Dimensions, Material, Slip-on plate combined with FIF-PN

Annex A 3

Appendix 4 / 8

Specifications of intended use

Anchorage subject to:

- The anchor may only be used for transmission of wind suction loads and shall not be used for the transmission of dead loads of the external thermal insulation composite system (ETICS).

Base materials:

- Normal weight concrete (use category A), according to Annex C1.
- Solid masonry (use category B), according to Annex C1.
- Hollow or perforated masonry (use category C), according to Annex C1.
- Lightweight aggregate concrete (use category D), according to Annex C1.
- Autoclaved aerated concrete (use category E), according to Annex C1.
- For other base materials of the use categories A, B, C, D or E, characteristic resistance of the anchor may be determined by job site tests acc. to EOTA Technical Report TR 051 Edition December 2016.

Temperature Range:

- 0°C to +40°C (max. short term temperature +40°C and max. long term temperature +24°C).

Design:

- The anchorages are designed under the responsibility of an engineer experienced in anchorages and masonry work with the partial safety factors $\gamma_M = 2,0$ and $\gamma_F = 1,5$, if there are no other national regulations.
- Verifiable calculation notes and drawings are prepared taking account of the loads to be anchored. The position of the anchors is indicated on the design drawings.
- Fasteners are only to be used for multiple fixings of ETICS.

Installation:

- Drill method according to Annex C1.
- Anchor installation carried out by appropriately qualified personnel and under the supervision of the person responsible for technical matters on the site.
- Installation temperature from 0°C to +40°C
- Exposure to UV due to solar radiation of the anchor not protected by rendering ≤ 6 weeks.

fischer FIF-PN

Intended use
Specification

Annex B 1

Appendix 5 / 8

Table B2.1: Installation parameters

Anchor type		FIF-PN
Drill hole diameter	$d_0 =$	8
Cutting diameter of drill bit	$d_{cut} \leq$	8,45
Depth of drill hole to deepest point	$h_1 \geq$	45 / 65 ¹⁾
Overall plastic anchor embedment depth in the base material	$h_{nom} \geq$	35 / 55 ¹⁾

¹⁾ only for use cat. "D" and "E"

Table B2.2: Minimum thickness, distance and spacing

Anchor type		FIF-PN
Minimum thickness of member	h_{min}	100
Minimum spacing	$s_{min} =$	100
Minimum edge distance	c_{min}	100

Scheme of distance and spacing

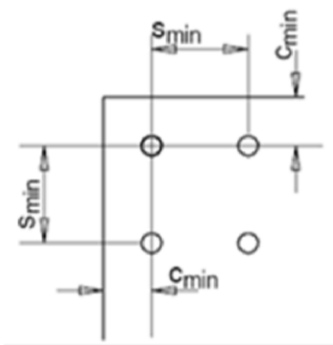

Figures not to scale

fischer FIF-PN

Intended use

Installation parameters, minimum thickness, distances and spacings

Annex B 2

Appendix 6 / 8

Installation instructions:

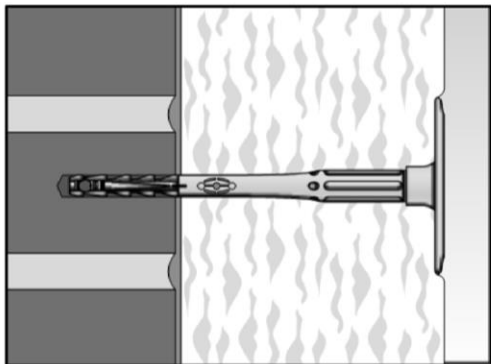
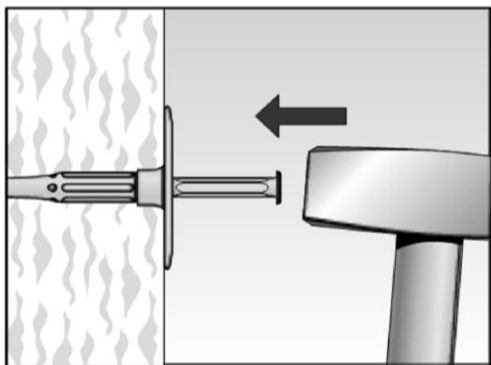
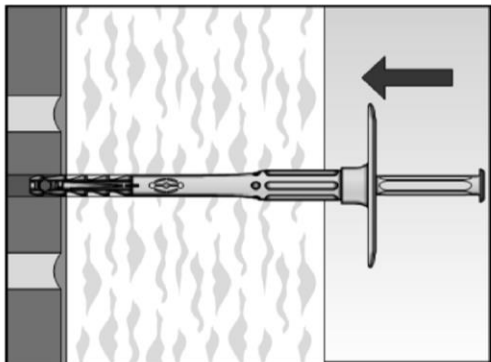
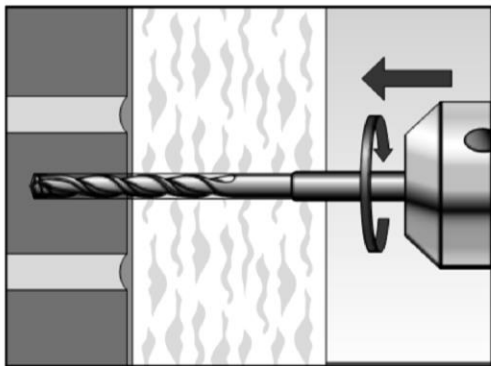

1. Drill the bore hole by the parameters acc. to Table B2.1 and the corresponding drilling method acc. to Annex C1.

2. Insert anchor manually.

3. Set anchor by hammer blows.

4. Correctly installed anchor.

Figures not to scale

fischer FIF-PN

Intended use
Installation instruction

Annex B 3

Appendix 7 / 8

Table C1.1: Characteristic tension resistance N_{RK} for a single anchor

Base material	Use cat.	Bulk density ρ [kg/dm ³]	Min. compressive strength f_b [N/mm ²]	Remarks	Drill ¹⁾ method	Characteristic resistance N_{RK} [kN]
Normal weight concrete \geq C12/15 – C50/60 acc. to EN 206:2013	A				H	0,5
Clay bricks Mz , acc. to EN 771-1:2011	B	$\geq 2,0$	12	Cross section reduced up to 15% by perforation vertically to the resting area	H	0,5
Vertically perforated clay bricks e.g. acc. to EN 771-1:2011, Hlz	C	$\geq 1,0$	12	Cross section between 15% and 50% by perforation vertically to the resting area. Exterior web thickness ≥ 12 mm	R	0,4
Lightweight Aggregate Concrete \geq LAC acc. to EN 1520:2011	D	$\geq 0,8$	6	Minimum thickness of brick or exterior web $t \geq 50$ mm	H	0,3
Autoclaved aerated concrete blocks, e.g. AAc acc. to EN 771-4 $h_{nom} = 35$ mm	E	$\geq 0,50$	4	DIN V 4165-100	R	0,3

¹⁾ H = Hammer drilling R = Rotary drilling

Table C1.2: Point thermal transmittance acc. to EOTA Technical Report TR 025: 2016-05

Anchor type	Thickness of insulation material h_D [mm]	Point thermal transmittance χ [W/K]
FIF-PN	60 - 180	0,000

Table C1.3: Plate stiffness acc. to EOTA Technical Report TR 026: 2016-05

Anchor type	Diameter of the anchor plate [mm]	Load resistance of the anchor plate [kN]	Plate stiffness [kN/mm]
FIF-PN	60	1,63	0,63

Table C1.4: Displacements of the FIF-PN

Base material	Tension load F [kN]	Displacement s δ [mm]
Concrete C12/15 – C50/60 (EN 206-1:2000)	0,15	< 0,2
Clay bricks, Mz 12 (EN 771-1:2011)	0,15	< 0,2
Vertically perforated Clay brick, Hlz 12 (EN 771-1:2011)	0,13	< 0,4
Lightweight Aggregate Concrete \geq LAC 6 DIN EN 1520	0,10	< 0,2
Autoclaved aerated concrete blocks, AAc 4 (EN 771-4) $h_{nom} = 35$ mm	0,10	< 0,2

fischer FIF-PN

Performance

Characteristic tension resistance, point thermal transmittance, plate stiffness, displacements

Annex C 1