



DECLARACIÓN DE PRESTACIONES



no 0005 – ES

1. Código de identificación única del producto tipo: **anclaje de expansión a golpes fischer EA II**

2. Usos previstos:

producto	Uso/s previsto/s
anclaje metálico para fijación de grandes cargas en hormigón	para anclar y/o apoyar elementos portantes de hormigón o elementos constructivos pesados, tales como revestimientos y falsos techos, Véase el apéndice, especialmente los anexos B 1 - B 4

3. Fabricante: **fischerwerke GmbH & Co. KG, Klaus-Fischer-Straße 1, 72178 Waldachtal, Germany**

4. Representante autorizado: --

5. Sistemas de evaluación y verificación de la constancia de las prestaciones (EVCP): **1**

6a. Norma armonizada: ---

Organismos notificados: ---

6b. Documento de evaluación europeo: **ETAG 001; 2013-04**

Evaluación técnica europea: **ETA-07/0135; 2015-01-28**

Organismo de evaluación técnica: **DIBt**

Organismos notificados: **1343 – MPA Darmstadt**

7. Prestaciones declaradas:

Resistencia mecánica y estabilidad (BWR 1)

indicación esencial	Prestaciones
valores característicos	Ver anexo, especialmente anexo C

protección contra incendios (BWR 2)

indicación esencial	Prestaciones
Reacción al fuego	el anclaje cumple con las exigencias de la clase A1.
resistencia al fuego	sin resistencia determinada (SRD)

8. Documentación técnica adecuada o documentación técnica específica: ---

Las prestaciones del producto identificado anteriormente son conformes con el conjunto de prestaciones declaradas. La presente declaración de prestaciones se emite, de conformidad con el Reglamento (UE) no 305/2011, bajo la sola responsabilidad del fabricante arriba identificado.

Firmado por y en nombre del fabricante por:

Andreas Bucher, Dipl.-Ing.

Wolfgang Hengesbach, Dipl.-Ing., Dipl.-Wirtsch.-Ing.

Tumlingen, 2015-02-03

- Este DoP ha sido redactado en varios idiomas. En caso de disputa acerca de la interpretación siempre prevalecerá la versión en inglés.

- el anexo contiene información voluntaria y complementaria en inglés, que va más allá de las exigencias legales.

Specific Part

1 Technical description of the product

The Fischer drop-in anchor EA II is an anchor made of galvanized or stainless steel which is placed into a drilled hole and anchored by deformation-controlled expansion.

The fixture shall be anchored with a fastening screw or threaded rod according to Annex 4.

The product description is given in Annex A.

2 Specification of the intended use in accordance with the applicable European Assessment Document

The performances given in Section 3 are only valid if the anchor is used in compliance with the specifications and conditions given in Annex B.

The verifications and assessment methods on which this European Technical Assessment is based lead to the assumption of a working life of the anchor of at least 50 years. The indications given on the working life cannot be interpreted as a guarantee given by the producer, but are to be regarded only as a means for choosing the right products in relation to the expected economically reasonable working life of the works.

3 Performance of the product and references to the methods used for its assessment

3.1 Mechanical resistance and stability (BWR 1)

Essential characteristic	Performance
Characteristic values	See Annex C

3.2 Safety in case of fire (BWR 2)

Essential characteristic	Performance
Reaction to fire	Anchorage satisfies requirements for Class A1
Resistance to fire	No performance determined (NPD)

3.3 Hygiene, health and the environment (BWR 3)

Not applicable.

3.4 Safety in use (BWR 4)

The essential characteristics regarding Safety in use are included under the Basic Works Requirement Mechanical resistance and stability.

3.5 Protection against noise (BWR 5)

Not applicable.

3.6 Energy economy and heat retention (BWR 6)

Not applicable.

3.7 Sustainable use of natural resources (BWR 7)

The sustainable use of natural resources was not investigated.

3.8 General aspects

The verification of durability is part of testing the essential characteristics. Durability is only ensured if the specifications of intended use according to Annex B are taken into account.

4 Assessment and verification of constancy of performance (AVCP) system applied, with reference to its legal base

According to Decision of the Commission of 24 June 1996 (96/582/EC) (OJ L 254 of 08.10.96 p. 62-65), the system of assessment and verification of constancy of performance (see Annex V and Article 65 Paragraph 2 to Regulation (EU) No 305/2011) given in the following table applies.

Product	Intended use(s)	Level or class	System
Metal anchors for use in concrete (heavy-duty type)	For fixing and/or supporting concrete structural elements or heavy units such as cladding and suspended ceilings	—	1

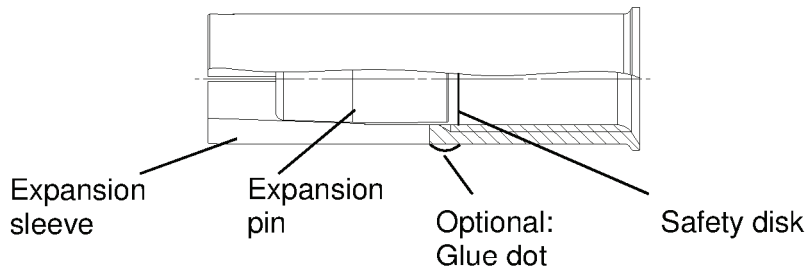
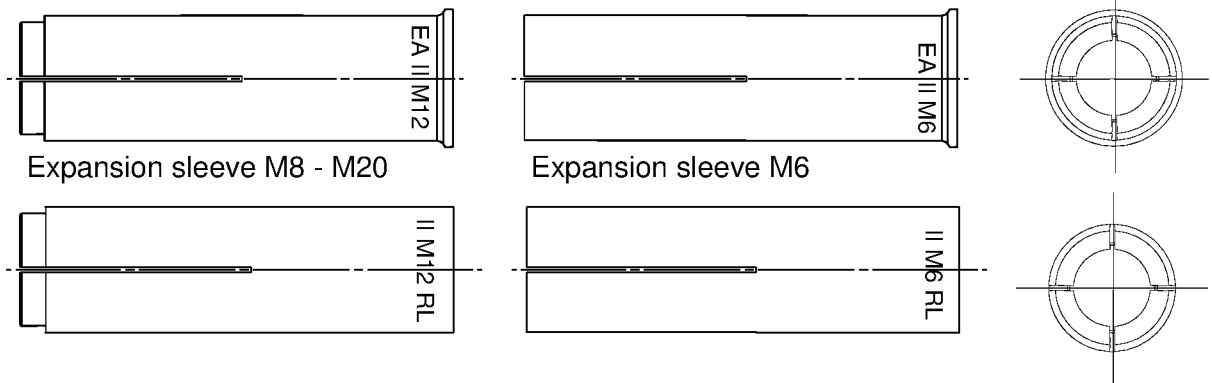

Intended use in concrete

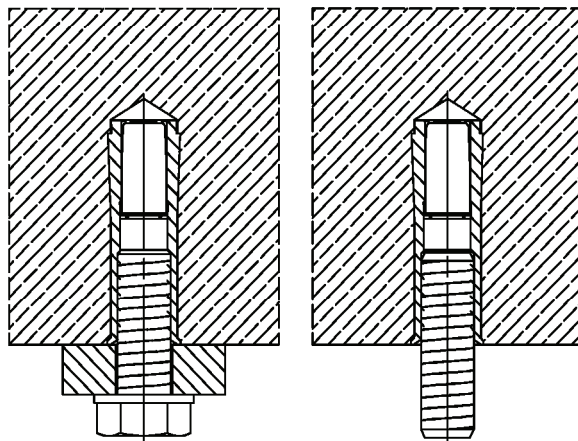

fischer drop-in anchor EA II

Product description
Anchor types
Installed condition

Annex A 1

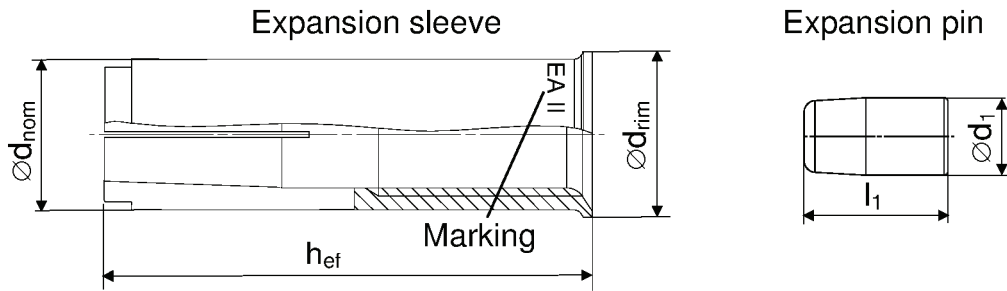

Anchor size EA II	M6x30	M8x30	M8x40	M10x30	M10x40	M12x50	M12x50 D	M16x65	M20x80
h_{ef} [mm]	30	30	40	30	40	50		65	80
$\varnothing d_{nom}$ [mm]	8	10		12		15	16	20	25
$\varnothing d_{rim}$ [mm]	9,5	11,5		13,5		16,5	17,5	21,5	27,0
$\varnothing d_1$ [mm]	5	6,5		8		10		13,5	17,5
l_1 [mm]	14	13,5		13,5	18,5	18,5		25	26

Distinctive feature



0x groove for:

- EA II M6x30..
- EA II M8x30..
- EA II M10x40..
- EA II M12x50..
- EA II M16x65..
- EA II M20x80..

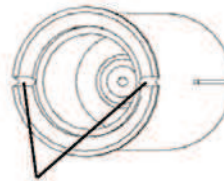

2x groove for:

- EA II M8x40..
- EA II M10x30..

Marking on anchor body

galvanized steel (gvz)		stainless steel (A4)	
with rim	rimless	with rim	rimless
EA II M6x30	EA II M6x30 RL	EA II M6x30 A4	EA II M6x30 RL A4
EA II M8x30	EA II M8x30 RL	EA II M8x30 A4	EA II M8x30 RL A4
EA II M8x40	EA II M8x40 RL	EA II M8x40 A4	EA II M8x40 RL A4
EA II M10x30	EA II M10x30 RL	EA II M10x30 A4	EA II M10x30 RL A4
EA II M10x40	EA II M10x40 RL	EA II M10x40 A4	EA II M10x40 RL A4
EA II M12x50	EA II M12x50 RL	EA II M12x50 A4	EA II M12x50 RL A4
EA II M12x50 D	EA II M12x50 RLD	EA II M12x50 DA4	EA II M12x50 RL DA4
EA II M16x65	EA II M16x65 RL	EA II M16x65 A4	EA II M16x65 RL A4
EA II M20x80	EA II M20x80 RL	EA II M20x80 A4	EA II M20x80 RL A4

fischer drop-in anchor EA II

Product description
Anchor types

Annex A 2

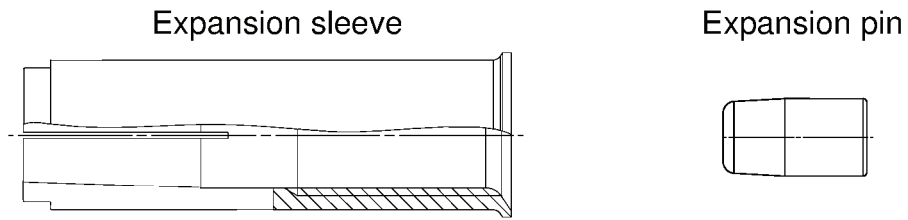

Table A1: Materials

Designation	Material	
	galvanised steel ($\geq 5 \mu\text{m}$)	stainless steel
Expansion sleeve	EN 10277:2008 or EN 10084:2008 or EN 10111:2008 or EN 10263:2001 or EN 10087:1998 or ASTM A29/A29M	EN 10088:2005
Expansion pin		
Fastening screw or threaded rod	steel, property class 4.6, 5.6, 5.8 or 8.8 according to EN ISO 898-1:2012	property class 50, 70 or 80 according to EN ISO 3506:2009

fischer drop-in anchor EA II

Product description
Material

Annex A 3

Specifications of intended use

Anchorage subject to:

- Static and quasi-static loads.

Base materials:

- Reinforced or unreinforced normal weight concrete according to EN 206-1:2000.
- Strength classes C20/25 to C50/60 according to EN 206-1:2000.
- Non-cracked concrete: all sizes.

Use conditions (Environmental conditions):

- Structures subject to dry internal conditions (zinc coated steel or stainless steel).
- Structures subject to external atmospheric exposure (including industrial and marine environment) and to permanently damp internal condition, if no particular aggressive conditions exist (stainless steel).

Note: Particular aggressive conditions are e.g. permanent, alternating immersion in seawater or the splash zone of seawater, chloride atmosphere of indoor swimming pools or atmosphere with extreme chemical pollution (e.g. in desulphurization plants or road tunnels where de-icing materials are used).

Design:

- Anchorages are designed under the responsibility of an engineer experienced in anchorages and concrete work.
- Verifiable calculation notes and drawings are prepared taking into account the loads to be anchored. The position of the anchor is indicated on the design drawings (e. g. position of the anchor relative to reinforcement or to supports, etc.).
- Anchorages under static or quasi-static actions are designed in accordance with: ETAG 001, Annex C, design method A, Edition August 2010.

Installation:

- Anchor installation carried out by appropriately qualified personnel and under the supervision of the person responsible for technical matters of the site.
- In case of aborted hole: new drilling at a minimum distance away of twice the depth of the aborted hole or smaller distance if the aborted drill hole is filled with high strength mortar and if under shear or oblique tension load it is not in the direction of load application.
- Anchor expansion by impact using the setting tools given in Annex B 4. The anchor is property set if the stop of the setting tool reaches the expansion sleeve. The manual setting tool with installation control leaves a visible mark on the sleeve, as illustrated in Annex B 4.

fischer drop-in anchor EA II

Annex B 1

Intended Use
Specifications

Table B2: Installation parameters for concrete C20/25 to C50/60

Anchor size			M6x30	M8x30	M8x40	M10x30	M10x40	M12x50	M12x50 D	M16x65	M20x80
Nominal drill hole diameter	d_0	[mm]	8	10		12		15	16	20	25
Effective anchorage depth	h_{ef}	[mm]	30	30	40	30	40	50		65	80
Maximum installation torque	max. T_{inst}	[Nm]	4	8		15		35		60	120
Minimum drill hole depth	h_1	[mm]	32	33	43	33	43	54		70	85
Minimum screw-in depth	$l_{s,min}$	[mm]	6	8		10		12		16	20
Maximum screw-in depth	$l_{s,max}$	[mm]	14	14		14	17	22		28	34
Clearance hole diameter	$\varnothing d_f$	[mm]	7	9		12		14		18	22
$h_{min} = 80$ mm											
Minimum spacing	S_{min}	[mm]	70	110	200	200		-	-	-	-
Minimum edge distance	C_{min}	[mm]	150	150		150		-	-	-	-
$h_{min} = 100$ mm											
Minimum spacing	S_{min}	[mm]	65	70	90	150	200		-	-	-
Minimum edge distance	C_{min}	[mm]	115	115		160	180	200		-	-
$h_{min} = 120$ mm											
Minimum spacing	S_{min}	[mm]	65	70	85	95	145		-	-	-
Minimum edge distance	C_{min}	[mm]	115	115		140	150	200		-	-
$h_{min} = 160$ mm											
Minimum spacing	S_{min}	[mm]	65	70	85	95	145		180	-	-
Minimum edge distance	C_{min}	[mm]	115	115		140	150	200		240	-
$h_{min} = 200$ mm											
Minimum spacing	S_{min}	[mm]	65	70	85	95	145		180	190	-
Minimum edge distance	C_{min}	[mm]	115	115		140	150	200		240	280

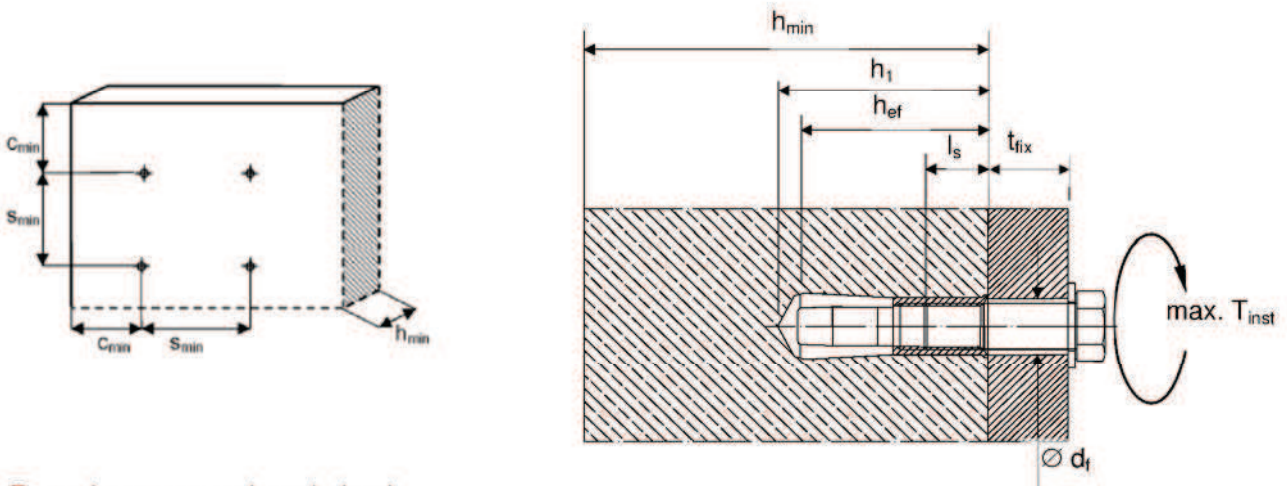

Fastening screw or threaded rod:

- Minimum property class and materials according to table A1.
- The length of the fastening screw or threaded rod shall be determined depending on thickness of fixture t_{fix} , admissible tolerances and maximum screw length $l_{s,max}$ as well as minimum screw-in depth $l_{s,min}$.

fischer drop-in anchor EA II

Intended Use
Installation parameters

Annex B 2







Setting & drilling tools			
Setting tools	Marking	Description	Marking on EA II with rim and rimless
	EHS Plus M..x h _{ef}	Manual setting tool with hand guard	
	EHS M..x h _{ef}	Manual setting tool basic format	
	EMS M..x h _{ef}	Machine setting tool with SDS Plus	No marking
	EAS M..x h _{ef}	Slip-on setting tool for stop drill	
Drilling tools			
	EBB ∅D x l	Stop drill	
Or other usual drillers			

Table B3: Parameters of setting tools

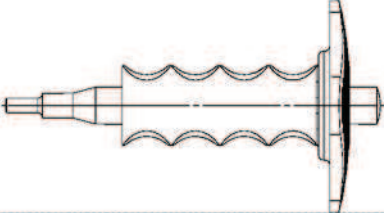
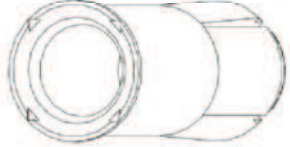
Manual setting tool	Machine setting tool	Slip-on setting tool	Stop drill	For anchor size EA II	∅ D ₁	∅ D ₂	L
EHS M6x25/30	EMS M6x25/30	EAS M6x25/30	EBB 8x30	EA II M6x30	4,8	9,0	17,0
EHS M8x25/30	EMS M8x25/30	EAS M8x25/30	EBB 10x30	EA II M8x30	6,4	11,0	18,0
EHS M8x40	EMS M8x40	EAS M8x40	EBB 10x40	EA II M8x40	6,4	11,0	28,0
EHS M10x25/30	EMS M10x25/30	EAS M10x25/30	EBB 12x30	EA II M10x30	7,9	13,0	18,0
EHS M10x40	EMS M10x40	EAS M10x40	EBB 12x40	EA II M10x40	7,9	13,0	24,0
EHS M12x50	EMS M12x50	EAS M12x50	EBB 15x50	EA II M12x50	10,2	16,5	30,0
EHS M16x65	EMS M16x65	EAS M16x65	EBB 20x65	EA II M16x65	13,5	22	36,0
EHS M20x80	EMS M20x80	EAS M20x80	EBB 25x80	EA II M20x80	16,4	27	50,0

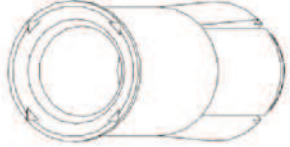
fischer drop-in anchor EA II

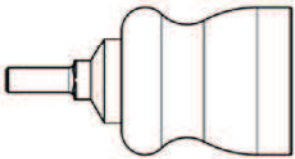
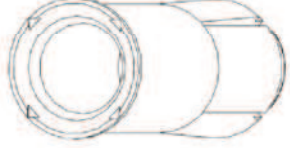
Intended Use
Setting & drilling tools

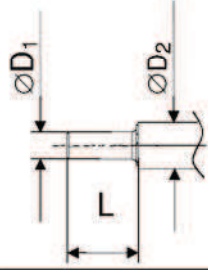
Annex B 3

Installation instructions

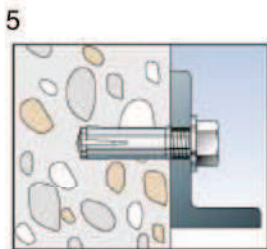
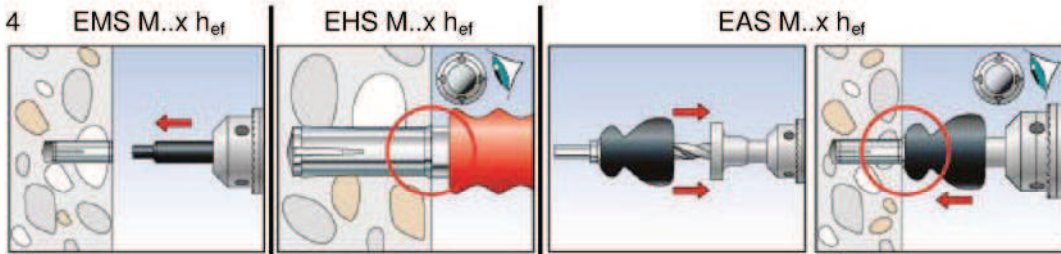
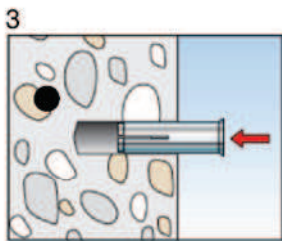
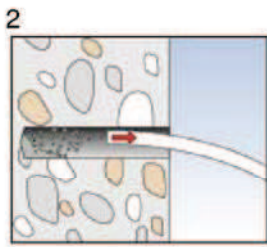
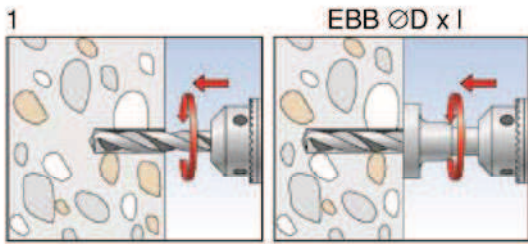

No.	Description
1	Create drill hole.
2	Clean from drill-dust.
3	Set anchor till anchor is flush with surface of concrete.
4	Expand the sleeve by driving the pin into the sleeve and control the correct setting.
5	Fixation of fixture with max. T _{inst.}

fischer drop-in anchor EA II

Intended Use
Installation instructions

Annex B 4

Table C1: Design method A - Characteristic resistance to tension loads

EA II		property class	M6x30 ²⁾	M8x30 ²⁾	M8x40	M10x30 ²⁾	M10x40	M12x50	M12x50 D	M16x65	M20x80
Steel failure											
Characteristic resistance	$N_{Rk,s}$ [kN]	A4-50	10,1	18,3		29,0		42,1		78,3	122,4
Partial safety factor	$\gamma_{Ms}^{1)}$		2,86								
Characteristic resistance	$N_{Rk,s}$ [kN]	A4-70	14,1	19,6		24,9	45,1	59,0	73,8	117,2	
Partial safety factor	$\gamma_{Ms}^{1)}$		1,87	1,5				1,87	1,5		
Characteristic resistance	$N_{Rk,s}$ [kN]	A4-80	16,1	19,6		24,9	45,1	59,0	73,8	117,2	
Partial safety factor	$\gamma_{Ms}^{1)}$		1,6	1,5							
Characteristic resistance	$N_{Rk,s}$ [kN]	steel 4.6	8,0	14,6		23,2		33,7		62,7	97,9
Partial safety factor	$\gamma_{Ms}^{1)}$		2,0								
Characteristic resistance	$N_{Rk,s}$ [kN]	steel 5.6	10,1	18,3		29,0		42,1		78,3	122,4
Partial safety factor	$\gamma_{Ms}^{1)}$		2,0								
Characteristic resistance	$N_{Rk,s}$ [kN]	steel 5.8	10,1	17,2		21,8	39,6	42,1	64,7	102,8	
Partial safety factor	$\gamma_{Ms}^{1)}$		1,5								
Characteristic resistance	$N_{Rk,s}$ [kN]	steel 8.8	13,5	17,2		21,8	39,6	53,3	64,7	102,8	
Partial safety factor	$\gamma_{Ms}^{1)}$		1,5								
Pull-out failure not decisive											
Concrete cone failure											
Effective anchorage depth	h_{ef}	[mm]	30	30	40	30	40	50	65	80	
Partial safety factor	$\gamma_{Mc}^{1)}$		1,5 ³⁾								
Characteristic spacing	$s_{cr,N}$	[mm]	90	90	120	90	120	150	195	240	
Characteristic edge distance	$c_{cr,N}$	[mm]	45	45	60	45	60	75	97	120	
Splitting failure											
Partial safety factor	$\gamma_{M,sp}^{1)}$		1,5 ³⁾								
Characteristic spacing	$s_{cr,sp}$	[mm]	210	210	280	210	320	350	455	560	
Characteristic edge distance	$c_{cr,sp}$	[mm]	105	105	140	105	160	175	227	280	

¹⁾ In absence of other national regulations.

²⁾ Only for application with statically indeterminate structural components.

³⁾ The installation safety factor $\gamma_2=1,0$ is included.

fischer drop-in anchor EA II

Performances
Design method A
Characteristic resistance to tension loads

Annex C 1

Table C2: Design method A - Characteristic resistance to shear loads

EA II		property class	M6x30 ²⁾	M8x30 ²⁾	M8x40	M10x30 ²⁾	M10x40	M12x50	M12x50 D	M16x65	M20x80
Steel failure without lever arm											
Characteristic resistance	$V_{Rk,s}$ [kN]	A4-50	5,0	9,2		14,5		21,1		39,2	61,2
Partial safety factor	$\gamma_{Ms}^{1)}$		2,38								
Characteristic resistance	$V_{Rk,s}$ [kN]	A4-70	7,0	9,8		12,4		22,6	29,5	37	59
Partial safety factor	$\gamma_{Ms}^{1)}$		1,56		1,25				1,56	1,25	
Characteristic resistance	$V_{Rk,s}$ [kN]	A4-80	8,0	9,8		12,4		22,6	30,4	36,9	58,6
Partial safety factor	$\gamma_{Ms}^{1)}$		1,33		1,25						
Characteristic resistance	$V_{Rk,s}$ [kN]	steel 4.6	4,0	7,3		11,6		16,9		31	49
Partial safety factor	$\gamma_{Ms}^{1)}$		1,67								
Characteristic resistance	$V_{Rk,s}$ [kN]	steel 5.6	5,0	9,2		14,5		21,1		39	61
Partial safety factor	$\gamma_{Ms}^{1)}$		1,67								
Characteristic resistance	$V_{Rk,s}$ [kN]	steel 5.8	5,0	8,6		10,9		19,8	21,1	32	51
Partial safety factor	$\gamma_{Ms}^{1)}$		1,25								
Characteristic resistance	$V_{Rk,s}$ [kN]	steel 8.8	6,8	8,6		10,9		19,8	27	32	51
Partial safety factor	$\gamma_{Ms}^{1)}$		1,25								
Steel failure with lever arm											
Characteristic resistance	$M^0_{Rk,s}$ [Nm]	A4-50	8	19		37		66		166	324
Partial safety factor	$\gamma_{Ms}^{1)}$		2,38								
Characteristic resistance	$M^0_{Rk,s}$ [Nm]	A4-70	11	26		52		92		232	454
Partial safety factor	$\gamma_{Ms}^{1)}$		1,56								
Characteristic resistance	$M^0_{Rk,s}$ [Nm]	A4-80	12	30		60		105		266	519
Partial safety factor	$\gamma_{Ms}^{1)}$		1,33								
Characteristic resistance	$M^0_{Rk,s}$ [Nm]	steel 4.6	6,1	15		30		52		133	259
Partial safety factor	$\gamma_{Ms}^{1)}$		1,67								
Characteristic resistance	$M^0_{Rk,s}$ [Nm]	steel 5.6	7,6	19		37		66		166	324
Partial safety factor	$\gamma_{Ms}^{1)}$		1,67								
Characteristic resistance	$M^0_{Rk,s}$ [Nm]	steel 5.8	7,6	19		37		66		166	324
Partial safety factor	$\gamma_{Ms}^{1)}$		1,25								
Characteristic resistance	$M^0_{Rk,s}$ [Nm]	steel 8.8	12	30		60		105		266	517
Partial safety factor	$\gamma_{Ms}^{1)}$		1,25								

¹⁾ In absence of other national regulations.

²⁾ Only for application with statically indeterminate structural components.

fischer drop-in anchor EA II

Annex C 2

Performances
Design method A
Characteristic resistance to shear loads

Table C3: Design method A - Characteristic resistance to shear loads

EA II	M6x30	M8x30	M8x40	M10x30	M10x40	M12x50	M12x50 D	M16x65	M20x80		
Concrete pryout failure											
Factor in equation (5.6) of ETAG 001 Annex C, 5.2.3.3	k		1,74	1,88	1,74	1,88	2,0				
Partial safety factor	$\gamma_{Mcp}^{1)}$		1,5 ²⁾								
Concrete edge failure											
Effective length of anchor in shear loading	l_f [mm]		30	30	40	30	40	50	65	80	
Effective diameter of anchor	$\varnothing d_{nom}$ [mm]		8	10		12		15	16	20	25
Partial safety factor	$\gamma_{Mc}^{1)}$		1,5 ²⁾								

¹⁾ In absence of other national regulations.

²⁾ The installation safety factor $\gamma_2=1,0$ is included.

fischer drop-in anchor EA II

Performances
Design method A
Characteristic resistance to shear loads

Annex C 3

Table C4.1: Displacements under tension and shear loads for EA II in galvanised steel

EA II			M6x30	M8x30	M8x40	M10x30	M10x40	M12x50	M12x50 D	M16x65	M20x80
Tension load in C20/25 to C50/60	N	[kN]	4,0	4,0	6,1	4,0	6,1	8,5		12,6	17,2
Displacement	δ_{N_0}	[mm]	0,1								
	δ_{N_∞}	[mm]	0,2								
Shear load in C20/25 to C50/60	V	[kN]	3,9	4,9	6,2	6,2		11,3	15,2	18,5	29,4
Displacement	δ_{V_0}	[mm]	0,95	1,00		1,05		1,10		1,40	1,80
	δ_{V_∞}	[mm]	1,40	1,50		1,60		1,70		2,10	2,70

Table C4.2: Displacements under tension and shear loads for EA II in stainless steel

EA II A4			M6x30	M8x30	M8x40	M10x30	M10x40	M12x50	M12x50 D	M16x65	M20x80
Tension load in C20/25 to C50/60	N	[kN]	4,0	4,0	6,1	4,0	6,1	8,5	8,5	12,6	17,2
Displacement	δ_{N_0}	[mm]	0,1								
	δ_{N_∞}	[mm]	0,2								
Shear load in C20/25 to C50/60	V	[kN]	3,2	5,6	7,1	7,1		12,9	13,5	21,1	33,5
Displacement	δ_{V_0}	[mm]	0,95	1,00		1,05		1,10		1,40	1,80
	δ_{V_∞}	[mm]	1,40	1,50		1,60		1,70		2,10	2,70

fischer drop-in anchor EA II

Performances
 Displacements
Annex C 4