

## DECLARATION OF PERFORMANCE

### DoP 0391

for fischer injection system FIS V Plus (Bonded fastener for use in concrete)

EN

1. Unique identification code of the product-type: **DoP 0391**
2. Intended use/es: **Post-installed fastening in cracked or uncracked concrete, see appendix, especially annexes B1 - B14.**
3. Manufacturer: **fischerwerke GmbH & Co. KG, Otto-Hahn-Straße 15, 79211 Denzlingen, Germany**
4. Authorised representative: **–**
5. System/s of AVCP: **1**
6. European Assessment Document: **EAD 330499-02-0601**  
 European Technical Assessment: **ETA-20/0603; 2026-01-29**  
 Technical Assessment Body: **DIBt- Deutsches Institut für Bautechnik**  
 Notified body/ies: **2873 TU Darmstadt**
7. Declared performance/s:  
**Mechanical resistance and stability (BWR 1)**  
**Characteristic resistance to tension load (static and quasi-static loading):**
  - 1) Resistance to steel failure: see appendix, especially annexes C1-C4
  - 2) Resistance to combined pull- out and concrete cone failure: see appendix, especially annexes C5-C11
  - 3) Resistance to concrete cone failure: see appendix, especially annex C5
  - 4) Edge distance to prevent splitting under load: see appendix, especially annex C5
  - 5) Robustness: see appendix, especially annexes C5 - C11
  - 6) Maximum installation torque: see appendix, especially annexes B3, B4, B5, B7
  - 7) Minimum edge distance and spacing: see appendix, especially annexes B3 - B9**Characteristic resistance to shear load (static and quasi-static loading):**
  - 8) Resistance to steel failure: see appendix, especially annexes C1-C4
  - 9) Resistance to pry-out failure: see appendix, especially annex C5
  - 10) Resistance to concrete edge failure: see appendix, especially annex C5**Displacements under short-term and long-term loading:**
  - 11) Displacements under short-term and long-term loading: see appendix, especially annexes C12, C13
  - 12) Resistance in steel fibre reinforced concrete: NPD**Characteristic resistance and displacements for seismic performance categories C1 and C2:**
  - 13) Resistance to tension load, displacements, category C1: see appendix, especially annexes C14,C16,C17
  - 14) Resistance to tension load, displacements, category C2: see appendix, especially annexes C15,C16,C18
  - 15) Resistance to shear load, displacements, category C1: see appendix, especially annexes C14,C16,C17
  - 16) Resistance to shear load, displacements, category C2: see appendix, especially annexes C15,C16,C18**Safety in case of fire (BWR 2)**
  - 17) Reaction to fire: Class (A1)**Resistance to fire:**
  - 18) Fire resistance to steel failure (tension load): NPD
  - 19) Bond resistance under fire conditions: NPD
  - 20) Fire resistance to steel failure under shear loading: NPD**Hygiene, health and the environment (BWR 3)**
  - 21) Content, emission and/or release of dangerous substances: NPD
8. Appropriate Technical Documentation and/or Specific Technical Documentation: **–**

The performance of the product identified above is in conformity with the set of declared performance/s. This declaration of performance is issued, in accordance with Regulation (EU) No 305/2011, under the sole responsibility of the manufacturer identified above.

Signed for and on behalf of the manufacturer by:



Alexander Zanocco, Managing Director Sales and Managing Director Research & Development

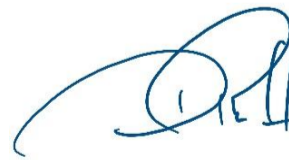

Dieter Pfaff, Head of International Production Federation and Quality Management

Tumlingen, 2026-03-01

This DoP has been prepared in different languages. In case there is a dispute on the interpretation the English version shall always prevail.

The Appendix includes voluntary and complementary information in English language exceeding the (language-neutrally specified) legal requirements.

Mechanical resistance and stability (BWR 1)		
Characteristic resistance to tension load (static and quasi-static loading):		
1	Resistance to steel failure:	$N_{Rk,s}$ [kN]
2	Resistance to combined pull-out and concrete cone failure:	$\tau_{Rk}$ and/or $\tau_{Rk,100}$ [N/mm <sup>2</sup> ], $\psi_c, \psi_{sus}^0, \psi_{sus,100}$ [-] (BF)
	Resistance to pull-out failure:	$N_{Rk,p}$ and/or $N_{Rk,p,100}$ [kN], $\psi_c$ [-] (BEF)
3	Resistance to concrete cone failure:	$c_{cr,N}$ [mm], $k_{cr,N}, k_{ucr,N}$ [-]
4	Edge distance to prevent splitting under load:	$c_{cr,sp}$ [mm]
5	Robustness:	$\gamma_{inst}$ [-]
6	Maximum installation torque:	$\max T_{inst}$ [Nm] (BF)
	Installation torque:	$T_{inst}$ [Nm] (BEF)
7	Minimum edge distance, spacing and member thickness:	$c_{min}, s_{min}, h_{min}$ [mm]
Characteristic resistance to shear load (static and quasi-static loading):		
8	Resistance to steel failure:	$V_{Rk,s}^0$ [kN], $M_{Rk,s}^0$ [Nm], $k_7$ [-]
9	Resistance to pry-out failure:	$k_8$ [-]
10	Resistance to concrete edge failure:	$d_{nom}, l_f$ [mm]
Displacements under short-term and long-term loading:		
11	Displacements factors under short-term and long-term loading:	$\delta_0, \delta_\infty$ [mm/(N/mm <sup>2</sup> )] or [mm/kN]
12	Resistance in steel fibre reinforced concrete:	Description
Characteristic resistance and displacements for seismic performance categories C1 and C2:		
13	Resistance to tension for seismic performance category C1	$N_{Rk,s,C1}$ [kN] (all) $\tau_{Rk,C1}$ [N/mm <sup>2</sup> ] (BF) $N_{Rk,p,C1}$ [kN] (BEF)
14	Resistance to tension and displacements for seismic performance category C2	$N_{Rk,s,C2}$ [kN] (all) $\tau_{Rk,C2}$ [N/mm <sup>2</sup> ] (BF) $N_{Rk,p,C2}$ [kN] (BEF) $\delta_{N,C2(50\%)}, \delta_{N,C2(100\%)}$ [mm] (all)
15	Resistance to shear for seismic performance category C1	$V_{Rk,s,C1}$ [kN] (all)
16	Resistance to shear load and displacements for seismic performance category C2	$V_{Rk,s,C2}$ [kN] (all) $\delta_{V,C2(50\%)}, \delta_{V,C2(100\%)}$ [mm] (all)
Safety in case of fire (BWR 2)		
17	Reaction to fire	Class
Resistance to fire		
18	Fire resistance to steel failure (tension load):	$N_{Rk,s,fi}$ [kN]
19	Bond resistance under fire conditions:	$k_{fi,p}(\theta)$ [-], $\tau_{Rk,fi}(\theta)$ [N/mm <sup>2</sup> ] (BF)
20	Fire resistance to steel failure under shear loading:	$V_{Rk,s,fi}$ [kN], $M_{Rk,s,fi}^0$ [Nm]
Hygiene, health and the environment (BWR 3)		
21	Content, emission and/or release of dangerous substances:	Description/Level

## Specific Part

### 1 Technical description of the product

The "fischer injection system FIS V Plus" is a bonded fastener consisting of a cartridge with injection mortar according to Annex A5 and a steel element according to Annex A1 to A4.

The steel element is placed into a drilled hole filled with injection mortar and is anchored via the bond between metal part, injection mortar and concrete.

The product description is given in Annex A.

### 2 Specification of the intended use in accordance with the applicable European Assessment Document

The performances given in Section 3 are only valid if the anchor is used in compliance with the specifications and conditions given in Annex B.

The verifications and assessment methods on which this European Technical Assessment is based lead to the assumption of a working life of the anchor of at least 50 and/or 100 years. The indications given on the working life cannot be interpreted as a guarantee given by the producer, but are to be regarded only as a means for choosing the right products in relation to the expected economically reasonable working life of the works.

### 3 Performance of the product and references to the methods used for its assessment

#### 3.1 Mechanical resistance and stability (BWR 1)

Essential characteristic	Performance
Characteristic resistance to tension load (static and quasi-static loading)	See Annex C1 to C11, B3 to B9
Characteristic resistance to shear load (static and quasi-static loading)	See Annex C1 to C4
Displacements under short-term and long-term loading	See Annex C12 to C13
Characteristic resistance and displacements for seismic performance categories C1 and C2	See Annex C14 to C18

#### 3.2 Safety in case of fire (BWR 2)

Essential characteristic	Performance
Reaction to fire	Class A1
Resistance to fire	No performance assessed

#### 3.3 Hygiene, health and the environment (BWR 3)

Essential characteristic	Performance
Content, emission and/or release of dangerous substances	No performance assessed

**4 Assessment and verification of constancy of performance (AVCP) system applied, with reference to its legal base**

In accordance with EAD 330499-02-0601 the applicable European legal act is: [96/582/EC].

The system to be applied is: 1

# Installation conditions part 1

fischer Anchor rod FIS A / RG (Anchor rod) and commercial standard Threaded rod (Threaded rod)

## Pre-positioned installation

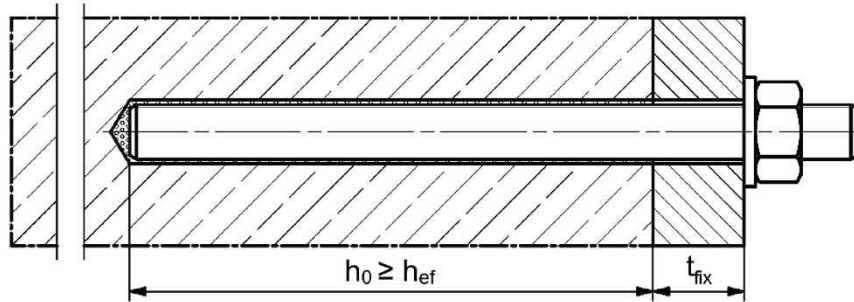

## Push through installation (annular gap filled with mortar)

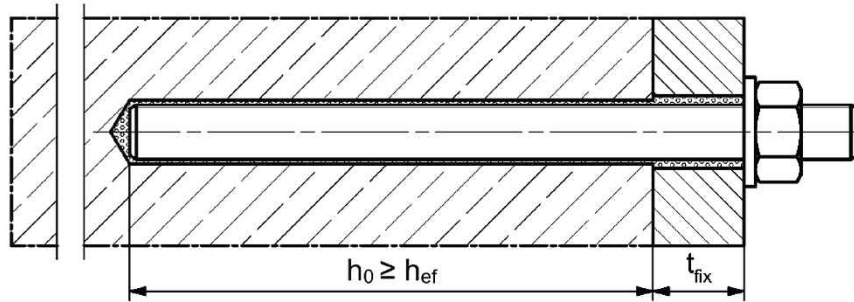

## Pre-positioned or push through installation with subsequently injected fischer filling disc (annular gap filled with mortar)

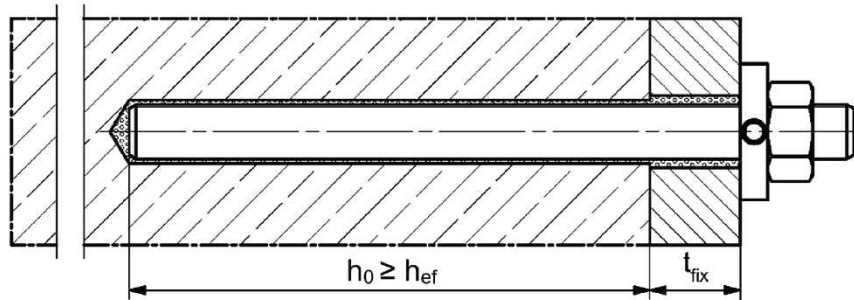

Figures not to scale

$h_0$  = drill hole depth

$h_{ef}$  = effective embedment depth

$t_{fix}$  = thickness of fixture

fischer injection system FIS V Plus

**Product description**  
Installation conditions part 1

**Annex A1**

Appendix 3 / 41

# Installation conditions part 2

## fischer internal threaded anchor RG M I (fischer RG M I)

### Pre-positioned installation

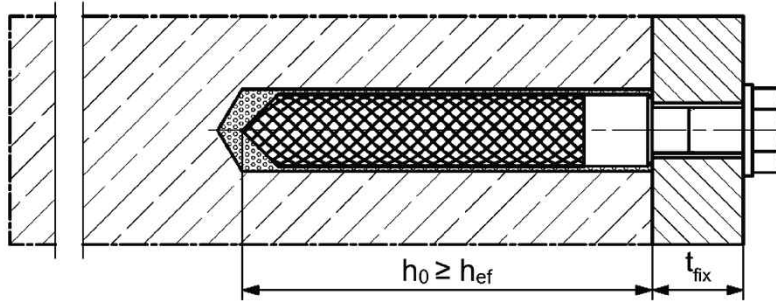

### Pre-positioned installation with subsequently injected fischer filling disc (annular gap filled with mortar)

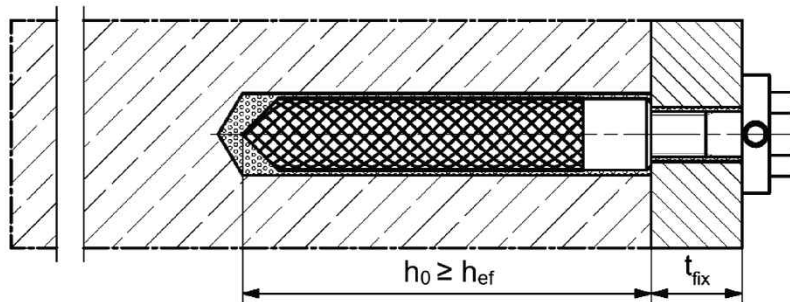

Figures not to scale

$h_0$  = drill hole depth

$h_{ef}$  = effective embedment depth

$t_{fix}$  = thickness of fixture

fischer injection system FIS V Plus

**Product description**  
Installation conditions part 2

**Annex A2**

Appendix 4 / 41

# Installation conditions part 3

## fischer internal threaded anchor FIS IG (fischer FIS IG)

### Pre-positioned installation

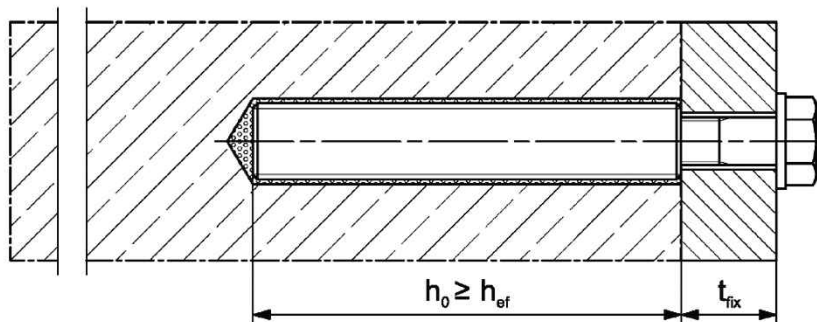

### Pre-positioned installation with subsequently injected fischer filling disc (annular gap filled with mortar)

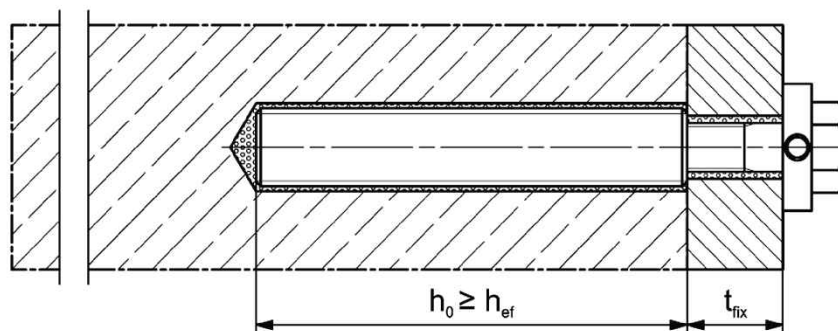

Figures not to scale

$h_0$  = drill hole depth

$h_{ef}$  = effective embedment depth

$t_{fix}$  = thickness of fixture

fischer injection system FIS V Plus

**Product description**  
Installation conditions part 3

**Annex A3**

Appendix 5 / 41

# Installation conditions part 4

## Reinforcing bar

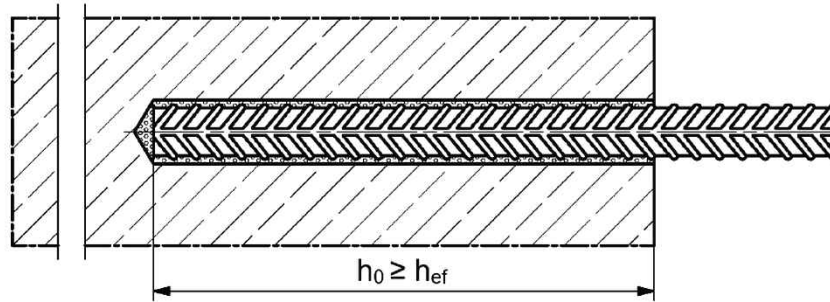

## fischer rebar Anchor FRA (fischer FRA)

### Pre-positioned installation

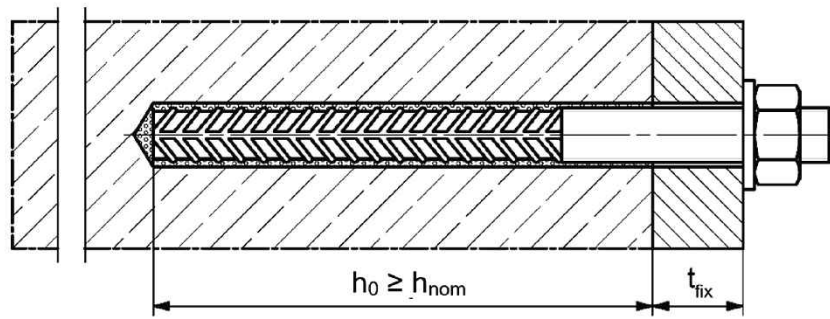

### Push through installation (annular gap filled with mortar)

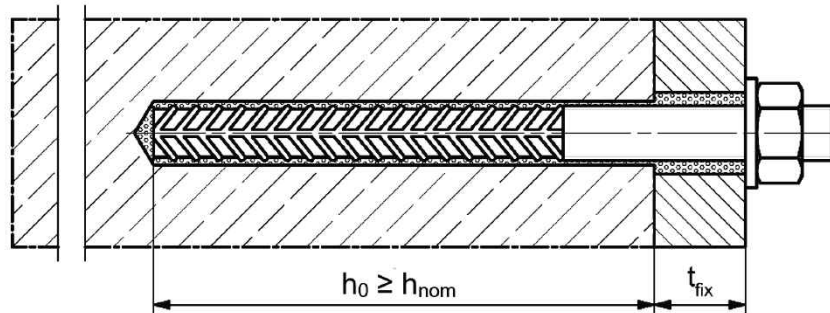

Figures not to scale

$h_0$  = drill hole depth

$h_{ef}$  = effective embedment depth

$t_{fix}$  = thickness of fixture

$h_{nom}$  = overall fastener embedment depth in the concrete

fischer injection system FIS V Plus

**Product description**  
Installation conditions part 4

**Annex A4**

Appendix 6 / 41

# Overview system components part 1

## Injection cartridge (shuttle cartridge) with sealing cap; Sizes: 360 ml, 825 ml

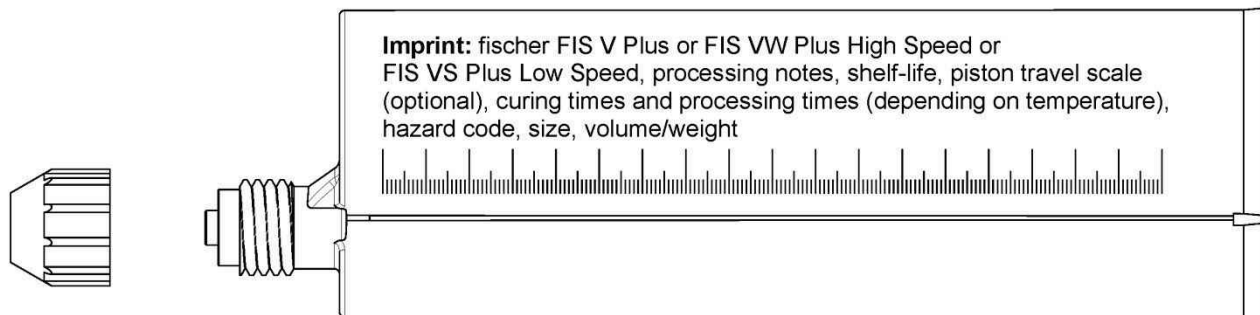

## Injection cartridge (coaxial cartridge) with sealing cap; Sizes: 100 ml, 150 ml, 300 ml, 380 ml, 400 ml, 410 ml

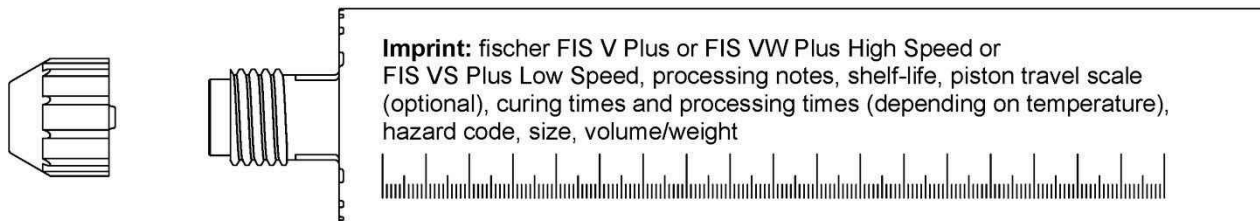

## Static mixer FIS MR Plus for injection cartridges up to 825 ml

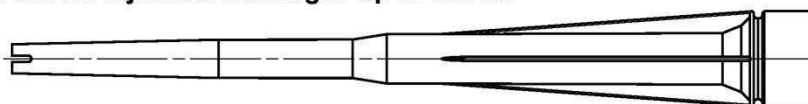

## Static mixer FIS JMR for injection cartridges of 825 ml

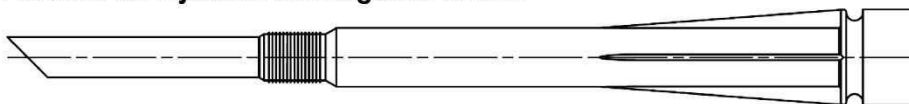

## Injection adapter and extension tube Ø 9 for static mixer FIS MR Plus; Injection adapter and extension tube Ø 9 or Ø 15 for static mixer FIS JMR

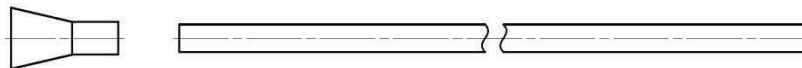

## Cleaning brush BS



## Blow-out pump AB G



## Compressed-air cleaning tool ABP



Figures not to scale

fischer injection system FIS V Plus

### Product description

Overview system components part 1;  
cartridges / static mixer / cleaning tools / injection adapter

**Annex A5**

Appendix 7 / 41

## Overview system components part 2

### Anchor rod / Threaded rod

Size: M6, M8, M10, M12, M16, M20, M24, M27, M30

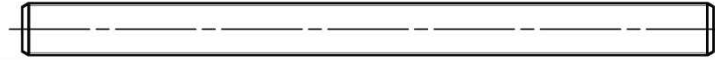

### fischer RG M I

Size: M8, M10, M12, M16, M20

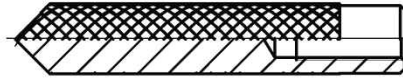

### fischer FIS IG

Size: M5, M6, M8, M10, M12, M16, M20

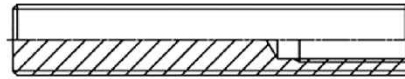

### Screw / Anchor rod / Threaded rod / washer / hexagon nut

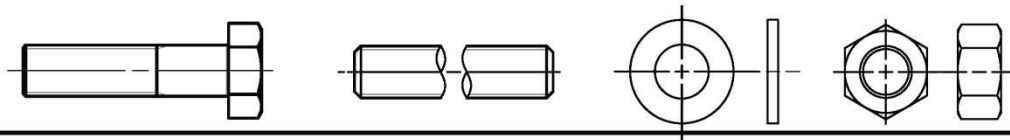

### fischer filling disc with injection adapter

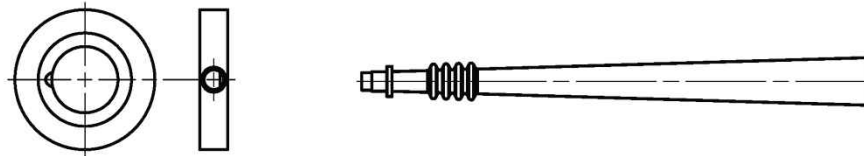

### fischer centering clip DD-S / DD-E

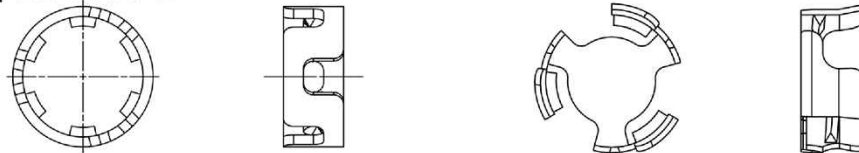

### Reinforcing bar

Nominal diameter:  $\phi 8$ ,  $\phi 10$ ,  $\phi 12$ ,  $\phi 14$ ,  $\phi 16$ ,  $\phi 20$ ,  $\phi 25$ ,  $\phi 28$



### fischer FRA, FRA HCR

Size: M12, M16, M20, M24



Figures not to scale

fischer injection system FIS V Plus

#### Product description

Overview system components part 2; metal parts, fischer centering clip, injection adapter

**Annex A6**

Appendix 8 / 41

**Table A7.1: Materials**

Part	Designation	Material		
1	Injection cartridge	Mortar, hardener, filler		
	Steel grade	Steel zinc plated (zp, hdg)	Stainless steel R acc. to EN 10088-1:2023 Corrosion resistance class CRC III acc. to EN 1993-1-4:2006+A1:2015	High corrosion resistant steel HCR acc. to EN 10088-1:2023 Corrosion resistance class CRC V acc. to EN 1993-1-4:2006+A1:2015
2	Anchor rod / Threaded rod	Property class 4.8, 5.8 or 8.8; EN ISO 898-1:2013 zp ≥ 5 µm, EN ISO 4042:2022 or hot dip galvanised ≥ 40 µm EN ISO 10684:2004+AC:2009 f <sub>uk</sub> ≤ 1000 N/mm <sup>2</sup> A <sub>5</sub> > 12 % fracture elongation <sup>1)</sup>	Property class 50, 70 or 80; EN ISO 3506-1:2020 1.4401; 1.4404; 1.4578; 1.4571; 1.4439; 1.4362; 1.4062; 1.4662; 1.4462; EN 10088-1:2023 f <sub>uk</sub> ≤ 1000 N/mm <sup>2</sup> A <sub>5</sub> > 12 % fracture elongation <sup>1)</sup>	Property class 50, 70 or 80; EN ISO 3506-1:2020 or property class HCR 70 with f <sub>yk</sub> ≥ 560 N/mm <sup>2</sup> ; 1.4565; 1.4529; EN 10088-1:2023 f <sub>uk</sub> ≤ 1000 N/mm <sup>2</sup> A <sub>5</sub> > 12 % fracture elongation <sup>1)</sup>
3	Washer ISO 7089:2000	zinc plated ≥ 5 µm, EN ISO 4042:2022 or hot dip galvanised ≥ 40 µm EN ISO 10684:2004+AC:2009	1.4401; 1.4404; 1.4578; 1.4571; 1.4439; 1.4362; EN 10088-1:2023	1.4565; 1.4529; EN 10088-1:2023
4	Hexagon nut	Property class 5 or 8 acc. EN ISO 898-2:2022 zinc plated ≥ 5 µm, EN ISO 4042:2022 or hot dip galvanised ≥ 40 µm EN ISO 10684:2004+AC:2009	Property class 50, 70 or 80 acc. EN ISO 3506-2:2020 1.4401; 1.4404; 1.4578; 1.4571; 1.4439; 1.4362; EN 10088-1:2023	Property class 50, 70 or 80 acc. EN ISO 3506-2:2020 1.4565; 1.4529; EN 10088-1:2023
5	fischer RG M I / FIS IG	Property class 5.8 EN ISO 898-1:2013 zinc plated ≥ 5 µm, EN ISO 4042:2022	Property class 70 EN ISO 3506-1:2020; 1.4401; 1.4404; 1.4578; 1.4571; 1.4439; 1.4362; EN 10088-1:2023	Property class 70 EN ISO 3506-1:2020 1.4565; 1.4529; EN 10088-1:2023
6	Commercial standard screw or Anchor rod / Threaded rod for fischer RG M I /FIS IG	Property class 5.8 or 8.8; EN ISO 898-1:2013 zinc plated ≥ 5 µm, EN ISO 4042:2022 A <sub>5</sub> > 8 % fracture elongation	Property class 70 EN ISO 3506-1:2020 1.4401; 1.4404; 1.4578; 1.4571; 1.4439; 1.4362; EN 10088-1:2023 A <sub>5</sub> > 8 % fracture elongation	Property class 70 EN ISO 3506-1:2020 1.4565; 1.4529; EN 10088-1:2023 A <sub>5</sub> > 8 % fracture elongation
7	fischer filling disc similar to DIN 6319-G	zinc plated ≥ 5 µm, EN ISO 4042:2022 or hot dip galvanised ≥ 40 µm EN ISO 10684:2004+AC:2009	1.4401; 1.4404; 1.4578; 1.4571; 1.4439; 1.4362; EN 10088-1:2023	1.4565; 1.4529; EN 10088-1:2023
8	Rebar	EN 1992-1-1:2004 and AC:2010, Annex C Bars and de-coiled rods, class B or C with f <sub>yk</sub> and k according to NDP or NCI according to EN 1992-1-1/NA; f <sub>uk</sub> = f <sub>tk</sub> = k · f <sub>yk</sub> (A <sub>5</sub> > 8 %) <sup>1)</sup>		
9	fischer FRA	Rebar part: Bars and de-coiled rods class B or C with f <sub>yk</sub> and k according to NDP or NCI of EN 1992-1-1:2004+AC:2010 f <sub>uk</sub> = f <sub>tk</sub> = k · f <sub>yk</sub> (A <sub>5</sub> > 8 %) Threaded part: Property class 80 EN ISO 3506-1:2020	1.4401, 1.4404, 1.4571, 1.4578, 1.4439, 1.4362, 1.4062 acc. to EN 10088-1:2023 Corrosion resistance class CRC III acc. to EN 1993-1-4:2006+A1:2015 1.4565; 1.4529 acc. to EN 10088-1:2023 Corrosion resistance class CRC V acc. to EN 1993-1-4:2006+A1:2015 f <sub>uk</sub> ≤ 1000 N/mm <sup>2</sup> ; fracture elongation A <sub>5</sub> > 8 %	

<sup>1)</sup> Fracture elongation A<sub>5</sub> > 8 %, for applications without requirements for seismic performance category C1 or C2

fischer injection system FIS V Plus

**Product description**  
Materials

**Annex A7**

Appendix 9 / 41

# Specifications of intended use part 1

**Table B1.1: Overview use and performance categories**

		FIS V Plus with ...									
		Anchor rod Threaded rod	fischer RG M I	fischer FIS IG	Reinforcing bar	fischer FRA					
Hammer drilling with standard drill bit 		all sizes									
Hammer drilling with hollow drill bit (fischer „FHD“, Heller „Duster Expert“; Bosch „Speed Clean“; Hilti „TE-CD, TE-YD“, DreBo „D-Plus“, DreBo „D-Max“)		Nominal drill bit diameter (d <sub>0</sub> ) 12 mm to 35 mm									
Static and quasi static load, in	uncracked concrete	all sizes	Tables: C1.1 C5.1 C6.1 C7.1 C8.1 C12.1	all sizes	Tables: C2.1 C5.1 C9.1 C12.2	all sizes	Tables: C3.1 C5.1 C6.1 C9.1 C12.2	all sizes	Tables: C4.1 C5.1 C10.1 C13.1	all sizes	Tables: C4.2 C5.1 C11.1 C13.2
	cracked concrete	M8 to M30	- <sup>2)</sup>	- <sup>2)</sup>	- <sup>2)</sup>	- <sup>2)</sup>	- <sup>2)</sup>	φ 10 to φ 28	- <sup>2)</sup>	- <sup>2)</sup>	- <sup>2)</sup>
Seismic performance category	C1 <sup>1)</sup>	M10 to M30	Tables: C14.1 C15.1 C16.1	All sizes			- <sup>2)</sup>	- <sup>2)</sup>	- <sup>2)</sup>	- <sup>2)</sup>	- <sup>2)</sup>
	C2 <sup>1)</sup>	M12 M16 M20	Tables: C15.1 C17.1 C18.1								
Use category	11 dry or wet concrete	all sizes									
	12 water filled hole	M12 to M30	all sizes	all sizes	- <sup>2)</sup>	- <sup>2)</sup>	- <sup>2)</sup>	- <sup>2)</sup>	- <sup>2)</sup>	- <sup>2)</sup>	- <sup>2)</sup>
Resistance to fire in concrete (only hammer drilling with standard / hollow drill bits)		- <sup>2)</sup>	- <sup>2)</sup>	- <sup>2)</sup>	- <sup>2)</sup>	- <sup>2)</sup>	- <sup>2)</sup>	- <sup>2)</sup>	- <sup>2)</sup>	- <sup>2)</sup>	- <sup>2)</sup>
Installation direction		D3 (downward and horizontal and upwards (e.g. overhead) installation)									
Installation temperature		T <sub>i,min</sub> = -10 °C to T <sub>i,max</sub> = +40 °C									
In-service temperature	Temperature range I	-40 °C to +80 °C			(max. short term temperature +80 °C; max. long term temperature +50 °C)						
	Temperature range II	-40 °C to +120 °C			(max. short term temperature +120 °C; max. long term temperature +72 °C)						

<sup>1)</sup> Not for FIS VW Plus High Speed and FIS VS Plus Low Speed

<sup>2)</sup> No performance assessed

fischer injection system FIS V Plus

**Intended use**  
Specifications part 1

**Annex B1**

Appendix 10 / 41

## Specifications of intended use part 2

### Base materials:

- Compacted reinforced or unreinforced normal weight concrete without fibres of strength classes C12/15 to C50/60 according to EN 206:2013+A2:2021.

### Use conditions (Environmental conditions):

- Fastener intended for use in structures subject to dry, internal conditions (all materials).
- For all other conditions according to EN 1993-1-4:2006+A1:2015 corresponding to corrosion resistance classes to **Annex A7 Table A7.1**.

### Design:

- Fastenings are designed in accordance with:  
EN 1992-4:2018.
- The structural design is conducted under responsibility of a designer experienced in the field of anchorages and concrete works.
- Verifiable calculation notes and drawings are to be prepared taking account of the loads to be anchored. The position of the fastener is indicated on the design drawings (e. g. position of the fastener relative to reinforcement or to supports, etc.).

### Installation:

- Fastener installation is to be carried out by appropriately qualified personnel and under the supervision of the person responsible for technical matters of the site.
- Fastening depth should be marked and adhered to installation.
- Overhead installation is allowed (necessary equipment see installation instruction).

fischer injection system FIS V Plus

**Intended use**  
Specifications part 2

**Annex B2**  
Appendix 11 / 41

**Table B3.1: Installation parameters for Anchor rods / Threaded rods**

Anchor rods / Threaded rods		Thread	M6	M8	M10	M12	M16	M20	M24	M27	M30	
Nominal drill hole diameter	$d_0$	[mm]	8	10	12	14	18	24	28	30	35	
Drill hole depth	$h_0^{3)}$		$h_0 \geq h_{ef}$									
Effective embedment depth	$h_{ef, min}$		40	40 <sup>2)</sup>	40 <sup>2)</sup>	48	64	80	96	108	120	
	$h_{ef, max}$		72	160	200	240	320	400	480	540	600	
Simplified spacing and edge distance <sup>1)</sup>	$s=c$		40	40	45	55	65	85	105	125	140	
Maximum diameter of the clearance hole of the fixture	pre-positioned installation $d_f$		7	9	12	14	18	22	26	30	33	
	push through installation $d_f$		9	12	14	16	20	26	30	33	40	
Minimum thickness of concrete member	$h_{min}$	$h_{ef} + 30 (\geq 100)$					$h_{ef} + 2d_0$					
Maximum installation torque	$\max T_{inst}$	[Nm]	5	10	20	40	60	120	150	200	300	

- 1) Detailed calculation according to **Annex B8 and B9**.
- 2)  $h_{ef, min} \geq 60$  for concrete C12/15 and C16/20
- 3) When using centering clips DD-S / DD-E, observe the deviating specifications as specified in **Table B11.1**.

**Anchor rod / Threaded rod**



**Marking (on random place) fischer Anchor rod:**

Steel zinc plated PC <sup>1)</sup> 8.8	• or +	Steel hot-dip PC <sup>1)</sup> 8.8	•
High corrosion resistant steel HCR PC <sup>1)</sup> 50	•	High corrosion resistant steel HCR PC <sup>1)</sup> 70	-
High corrosion resistant steel HCR PC <sup>1)</sup> 80	(	Stainless steel R property class 50	~
Stainless steel R property class 80	*		

Alternatively: Colour coding according to DIN 976-1: 2016

<sup>1)</sup> PC = property class

**Installation conditions:**

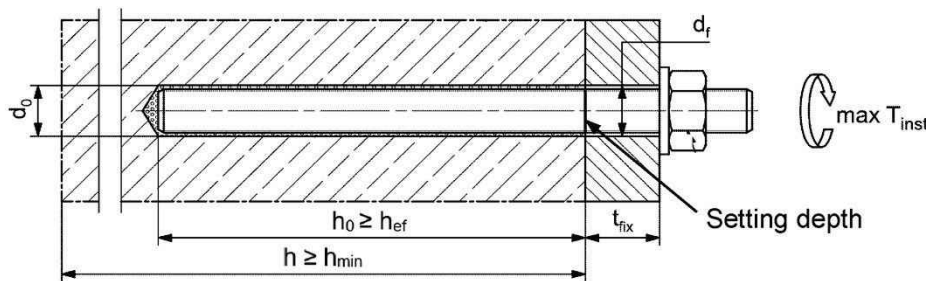

**Threaded rods, washers and hexagon nuts may also be used if the following requirements are fulfilled:**

- Materials, dimensions and mechanical properties according to **Annex A7, Table A7.1**.
- Inspection certificate 3.1 according to EN 10204:2004, the documents have to be stored.
- Setting depth is marked.
- Steel load-bearing capacities for hot-dip galvanised parts are only valid if the threaded rod and nut are correctly paired. The strength class of the nut must be one strength class higher than that of the threaded rod ( $\geq M12$  in combination with tolerance class 6AX in accordance with EN ISO 10684:2004+AC:2009 two strength classes higher). The pairing of undersized threaded rods (additional designation U according to EN ISO 10684) with oversized nuts (additional designation Z or X according to EN ISO 10684) is not permitted under any circumstances.

Figures not to scale

fischer injection system FIS V Plus

**Intended use**  
Installation parameters Anchor rods / Threaded rods

**Annex B3**

Appendix 12 / 41

**Table B4.1: Installation parameters for fischer RG M I**

fischer RG M I		Thread	M8	M10	M12	M16	M20
Diameter of Anchor	$d_{nom} = d_H$	[mm]	12	16	18	22	28
Nominal drill hole diameter	$d_0$		14	18	20	24	32
Drill hole depth	$h_0$		$h_0 \geq h_{ef} = L_H$				
Effective embedment depth ( $h_{ef} = L_H$ )	$h_{ef}$		90	90	125	160	200
Minimum spacing and minimum edge distance	$s_{min}$ = $c_{min}$		55	65	75	95	125
Maximum diameter of clearance hole in the fixture	$d_f$		9	12	14	18	22
Minimum thickness of concrete member	$h_{min}$		120	125	165	205	260
Maximum screw-in depth	$l_{E,max}$		18	23	26	35	45
Minimum screw-in depth	$l_{E,min}$	8	10	12	16	20	
Maximum installation torque	$\max T_{inst}$	[Nm]	10	20	40	80	120

**fischer RG M I**

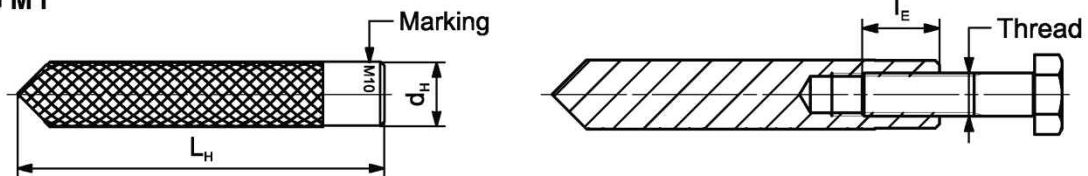

**Marking:** Anchor size e. g.: **M10**  
 Stainless steel → additional **R**; e.g.: **M10 R**  
 High corrosion resistant steel → additional **HCR**; e.g.: **M10 HCR**

Retaining bolt or Anchor rod / Threaded rods (including nut and washer) must comply with the appropriate material and strength class of **Annex A7, Table A7.1**.

**Installation conditions:**

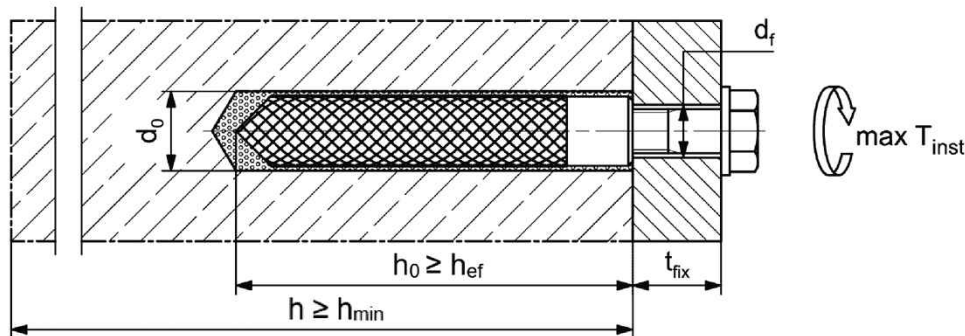

Figures not to scale

fischer injection system FIS V Plus

**Intended use**  
 Installation parameters fischer RG M I

**Annex B4**  
 Appendix 13 / 41

**Table B5.1: Installation parameters for fischer FIS IG**

fischer FIS IG		Thread	M5	M6	M8	M10	M12	M16	M20
Diameter of anchor	$d_{nom} = d_H$	[mm]	10	10	12	16	20	24	30
Nominal drill hole diameter	$d_0$		12	12	14	18	24	28	35
Drill hole depth	$h_0$ <sup>1)</sup>		$h_0 \geq h_{ef} = L_H$						
Effective embedment depth ( $h_{ef} = L_H$ )	$h_{ef, min}$		40 <sup>2)</sup>	40 <sup>2)</sup>	48	64	80	96	120
	$h_{ef, max}$		200	200	240	320	400	480	600
Minimum spacing	$s_{min}$		according to Annex B8						
Minimum edge distance	$c_{min}$		according to Annex B8						
Diameter of clearance hole in the fixture	$d_f$		6	7	9	12	14	18	22
Minimum thickness of concrete member	$h_{min}$ <sup>1)</sup>		$h_{ef} + 30 (\geq 100)$			$h_{ef} + 2d_0$			
			18	18	20	25	30	40	50
Maximum screw-in depth	$l_{E, max}$	8	8	10	12	14	19	23	
Minimum screw-in depth	$l_{E, min}$	5	5	10	20	40	80	120	
Maximum installation torque	$\max T_{inst}$	[Nm]	5	5	10	20	40	80	120

- 1) When using centering clips DD-S / DD-E, observe the deviating specifications as specified in **Table B11.1**.
- 2)  $h_{ef, min} \geq 60$  for concrete C12/15 and C16/20.

**fischer FIS IG**

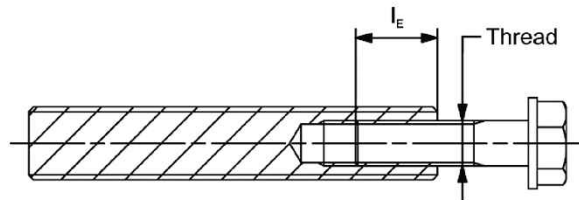
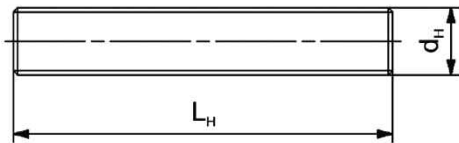

**Marking (at any location) Anchor rod:**

High corrosion resistant steel HCR property class 70

Bolts or threaded rods (including nut and washer) must comply with the relevant material and strength class as specified in **Annex A7, Table A7.1**.

**Installation conditions:**

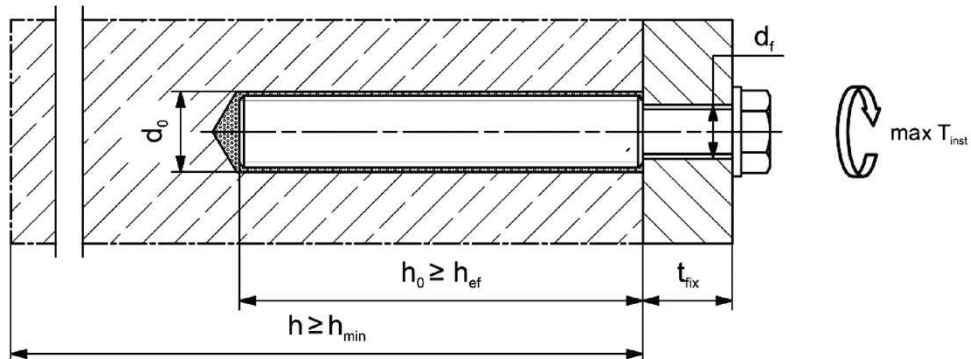

Figures not to scale

fischer injection system FIS V Plus

**Intended use**  
Installation parameters fischer FIS IG

**Annex B5**  
Appendix 14 / 41

**Table B6.1: Installation parameters for reinforcing bars**

Nominal diameter of the bar		$\phi$	8 <sup>2)</sup>	10 <sup>2)</sup>	12 <sup>2)</sup>	14	16	20	25	28			
Nominal drill hole diameter	$d_0$	[mm]	10	12	12	14	14	16	18	20	25	30	35
Drill hole depth	$h_0$		$h_0 \geq h_{ef}$										
Effective embedment depth	$h_{ef,min}$		60	60	70	75	80	90	100	112			
	$h_{ef,max}$		160	200	240	280	320	400	500	560			
Simplified spacing and edge distance <sup>1)</sup>	$s = c$		40	45	55	60	65	85	110	130			
Minimum thickness of concrete member	$h_{min}$	$h_{ef} + 30$ ( $\geq 100$ )				$h_{ef} + 2d_0$							

<sup>1)</sup> Detailed calculation according to **Annex B8** and **B9**.

<sup>2)</sup> Both drill hole diameters can be used.

**Reinforcing bar**



- The minimum value of related rib area  $f_{R,min}$  must fulfil the requirements of EN 1992-1-1:2011.
- The rib height must be within the range:  $0,05 \cdot \phi \leq h_{rib} \leq 0,07 \cdot \phi$   
( $\phi$  = Nominal diameter of the bar,  $h_{rib}$  = rib height).

**Installation conditions:**

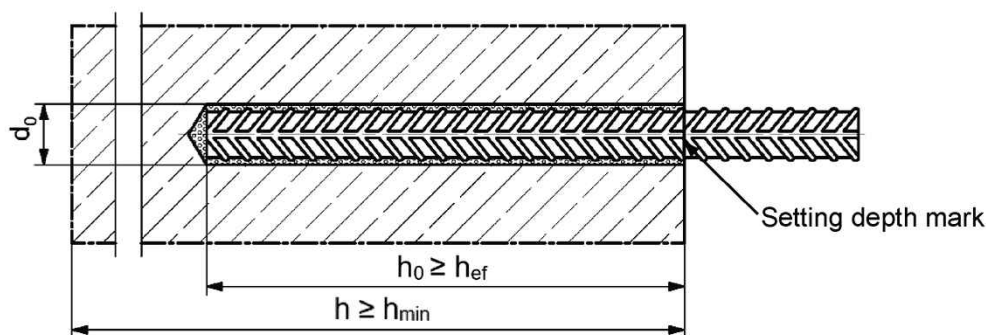

Figures not to scale

fischer injection system FIS V Plus

**Intended use**  
Installation parameters reinforcing bars

**Annex B6**

Appendix 15 / 41

**Table B7.1: Installation parameters for fischer FRA**

fischer FRA		Thread	M12 <sup>2)</sup>	M16	M20	M24	
Nominal diameter of the bar	$\phi$	[mm]	12		16	20	25
Nominal drill hole diameter	$d_0$		14	16	20	25	30
Drill hole depth	$h_0$		$h_{ef} + l_e = h_{nom}$				
Effective embedment depth	$h_{ef,min}$		70	80	90	96	
	$h_{ef,max}$		140	220	300	380	
Distance concrete surface to welded joint	$l_e$		100				
Simplified spacing and edge distance <sup>1)</sup>	$s$		55	65	85	105	
	$c$						
Maximum Diameter of clearance hole in the fixture	pre-positioned anchorage $d_f$		14	18	22	26	
	push through anchorage $d_f$		18	22	26	32	
Minimum thickness of concrete member	$h_{min}$	$h_0 + 30$ ( $\geq 100$ )	$h_0 + 2d_0$				
Maximum installation torque	$\max T_{inst}$	[Nm]	40	60	120	150	

1) Detailed calculation according to **Annex B8** and **B9**.

2) Both drill hole diameters can be used.

**fischer FRA**

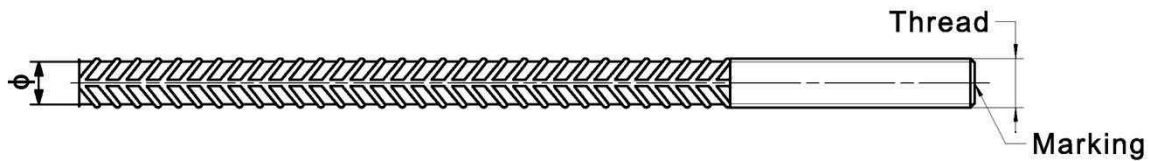

Marking frontal e.g:

- FRA (for stainless steel);
- FRA HCR (for high corrosion resistant steel HCR)

**Installation conditions:**

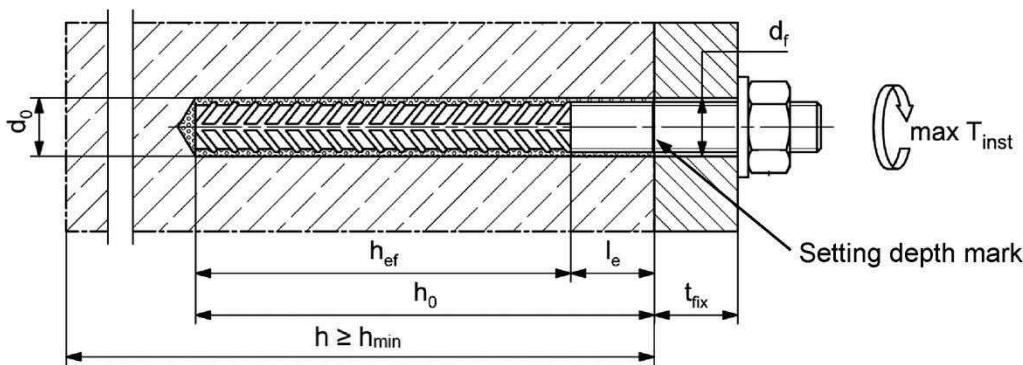

Figures not to scale

fischer injection system FIS V Plus

**Intended use**  
Installation parameters fischer FRA

**Annex B7**

Appendix 16 / 41

**Table B8.1: Minimum spacing and minimum edge distance for Anchor rods / Threaded rods, reinforcing bars, fischer FIS IG and fischer FRA**

<b>Anchor rods / Threaded rods</b>		<b>M6</b>	<b>M8</b>	<b>M10</b>	-	-	-	<b>M12</b>	-	-	<b>M16</b>	-	
<b>fischer FIS IG</b>		-	-	-	<b>M5</b>	<b>M6</b>	<b>M8</b>	-	<b>M10</b>	-	-	<b>M12</b>	
<b>Reinforcing bars / fischer FRA (nominal diameter)</b>		$\phi$	<b>8</b>	<b>10</b>	-	-	-	<b>12</b>	-	<b>14</b>	<b>16</b>	-	
<b>Minimum edge distance</b>													
Uncracked / cracked concrete	$c_{min}$	[mm]	40	40	45	40	45	45	45	50	45	50	55
Minimum spacing	s		according to <b>Annex B9</b>										
<b>Minimum spacing</b>													
Uncracked / cracked concrete	$s_{min}$	[mm]	40	40	45	40	45	55	55	65	60	65	85
Minimum edge distance	c		according to <b>Annex B9</b>										
<b>Required projecting area</b>													
Uncracked concrete C12/15 and	$A_{sp,req}$	[1000 mm <sup>2</sup> ]	-	11,3	18,3	5,0	5,0	7,8	31,0	11,3	-	33,8	18,4
Cracked concrete C16/20			-	9,2	14,1	3,6	3,6	6,4	23,2	9,2	-	26,1	14,1
Uncracked concrete $\geq$ C20/25			8,0	8,0	13,0	3,5	3,5	5,5	22,0	8,0	23,0	24,0	13,0
Cracked concrete $\geq$ C20/25			6,5	6,5	10,0	2,5	2,5	4,5	16,5	6,5	17,5	18,5	10,0
<b>Anchor rods / Threaded rods</b>													
		<b>M20</b>	-	<b>M24</b>	-	<b>M27</b>	-					<b>M30</b>	
<b>fischer IG</b>		-	<b>M16</b>	-	-	-	-			<b>M20</b>		-	
<b>Reinforcing bars / fischer FRA (nominal diameter)</b>		$\phi$	<b>20</b>	-	-	<b>25</b>	-	<b>28</b>				-	
<b>Minimum edge distance</b>													
Uncracked / cracked concrete	$c_{min}$	[mm]	55	60	60	75	75	80	80	80	80	80	
Minimum spacing	s		according to <b>Annex B9</b>										
<b>Minimum spacing</b>													
Uncracked / cracked concrete	$s_{min}$	[mm]	85	105	105	120	120	140	140	140	140	140	
Minimum edge distance	c		according to <b>Annex B9</b>										
<b>Required projecting area</b>													
Uncracked concrete C12/15 and	$A_{sp,req}$	[1000 mm <sup>2</sup> ]	54,2	30,3	56,3	-	66,9	-	36,7	90,1			
Cracked concrete C16/20			51,5	23,3	42,9	-	51,4	-	28,2	69,0			
Uncracked concrete $\geq$ C20/25			38,5	21,5	40,0	47,5	47,5	64,0	26,0	64,0			
Cracked concrete $\geq$ C20/25			29,5	16,5	30,5	36,5	36,5	49,0	20,0	49,0			

**Splitting failure** for minimum edge distance and spacing in dependence of the effective embedment depth  $h_{ef}$ .

For the calculation of minimum spacing and minimum edge distance of anchors in combination with different embedment depths and thicknesses of concrete members the following equation shall be fulfilled:

$$A_{sp,req} < A_{sp,t}$$

$A_{sp,req}$  = required projecting area

$A_{sp,t}$  = projecting area (according to **Annex B9**)

fischer injection system FIS V Plus

**Intended use**

Minimum spacing and edge distance for Anchor rods / Threaded rods, fischer FIS IG, reinforcing bars and fischer FRA

**Annex B8**

Appendix 17 / 41

**Table B9.1: Projecting area  $A_{sp,t}$  with concrete member thickness  $h > h_{ef} + 1,5 \cdot c$  and  $h \geq h_{min}$**

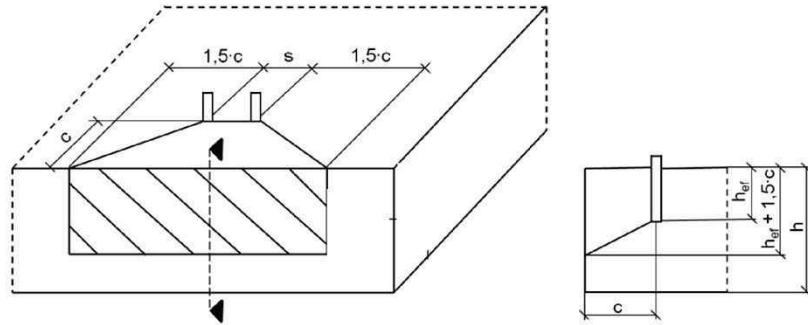

Single fastener	$A_{sp,t} = (3 \cdot c) \cdot (h_{ef} + 1,5 \cdot c)$	[mm <sup>2</sup> ]	with $c \geq c_{min}$
Group of fastener with $s > 3 \cdot c$	$A_{sp,t} = (6 \cdot c) \cdot (h_{ef} + 1,5 \cdot c)$	[mm <sup>2</sup> ]	
Group of fastener with $s \leq 3 \cdot c$	$A_{sp,t} = (3 \cdot c + s) \cdot (h_{ef} + 1,5 \cdot c)$	[mm <sup>2</sup> ]	with $c \geq c_{min}$ and $s \geq s_{min}$

**Table B9.2: Projecting area  $A_{sp,t}$  with concrete member thickness  $h \leq h_{ef} + 1,5 \cdot c$  and  $h \geq h_{min}$**

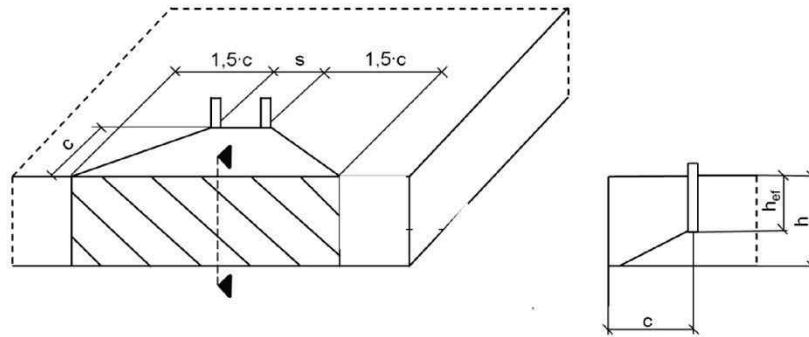

Single fastener	$A_{sp,t} = 3 \cdot c \cdot \text{existing } h$	[mm <sup>2</sup> ]	with $c \geq c_{min}$
Group of fastener with $s > 3 \cdot c$	$A_{sp,t} = 6 \cdot c \cdot \text{existing } h$	[mm <sup>2</sup> ]	
Group of fastener with $s \leq 3 \cdot c$	$A_{sp,t} = (3 \cdot c + s) \cdot \text{existing } h$	[mm <sup>2</sup> ]	with $c \geq c_{min}$ and $s \geq s_{min}$

Edge distance and axial spacing shall be rounded up to at least 5 mm.

Figures not to scale

fischer injection system FIS V Plus

**Intended use**

Minimum thickness of concrete member for Anchor rods / Threaded rods, fischer FIS IG, fischer FRA and reinforcing bars, minimum spacing and edge distance

**Annex B9**

Appendix 18 / 41

**Table B10.1: Parameters of the cleaning brush BS (steel brush with steel bristles)**

The size of the cleaning brush refers to the drill hole diameter.

Nominal drill hole diameter	$d_0$	[mm]	8	10	12	14	16	18	20	24	25	28	30	32	35
Steel brush diameter BS	$d_b$		9	11	14	16	20		25	26	27	30	40		

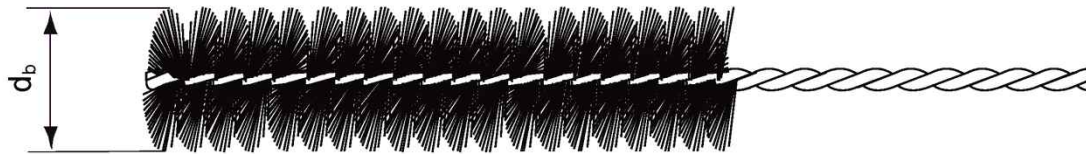

**Table B10.2: Maximum processing time of the mortar and minimum curing time**  
(During the curing time of the mortar the concrete temperature may not fall below the listed minimum temperature)

Temperature at anchoring base [°C]	Maximum processing time $t_{work}$			Minimum curing time $t_{cure}$ <sup>1)</sup>		
	FIS VW Plus High Speed	FIS V Plus	FIS VS Plus Low Speed	FIS VW Plus High Speed	FIS V Plus	FIS VS Plus Low Speed
-10 to -5 <sup>2)</sup>	5 min	-	-	12 h	-	-
> -5 to 0 <sup>2)</sup>	5 min	13 min	-	3 h	24 h	-
> 0 to 5 <sup>2)</sup>	5 min	13 min	20 min	3 h	3 h	6 h
> 5 to 10	3 min	9 min	20 min	50 min	90 min	3 h
> 10 to 20	1 min	5 min	10 min	30 min	60 min	2 h
> 20 to 30	-	4 min	6 min	-	45 min	60 min
> 30 to 40	-	2 min	4 min	-	35 min	30 min

<sup>1)</sup> In wet concrete or water filled holes the curing times must be doubled.

<sup>2)</sup> Minimal cartridge temperature +5°C.

**Table B10.3: Conditions for use static mixer without an extension tube**

Nominal drill hole diameter	$d_0$	[mm]	8	10	12	14	16	18	20	24	25	28	30	32	35
Drill hole depth $h_0$ by using	FIS MR Plus		≤90			≤120	≤140	≤150	≤160	≤190	≤210				
	FIS JMR	-	-	-	≤90	≤160	≤180	≤190	≤220			≤250			

fischer injection system FIS V Plus

**Intended use**  
Cleaning brush (steel brush)  
Processing time and curing time

**Annex B10**  
Appendix 19 / 41

**Table B11.1: Parameters of the fischer centering clip DD-S / DD-E**

<b>Anchor rods / Threaded rods</b>			<b>M12</b>	<b>M16</b>	<b>M20</b>	<b>M24</b>	<b>M27</b>	<b>M30</b>
<b>fischer FIS IG</b>			<b>M8</b>	<b>M10</b>	<b>M12</b>	<b>M16</b>	-	<b>M20</b>
<b>fischer centering clip DD-S / DD-E</b>			<b>M12</b>	<b>M16</b>	<b>M20</b>	<b>M24</b>	<b>M27</b>	<b>M30</b>
fischer centering clip DD-S	$h_{DD-S}$	[mm]	6,5	8,0	9,0	10,0	10,0	10,0
fischer centering clip DD-E	$h_{DD-E}$	[mm]	12,0	13,5	18,0	19,0	19,0	19,0
Drill hole depth	$h_0$	[mm]	$h_0 \geq h_{nom} + 3 \text{ mm}$					
Minimum thickness of concrete member	$h_{min}$	[mm]	$h_{nom} + 30$ ( $\geq 100$ )	$h_{nom} + 2d_0$				

The uppermost DD-S clip should be positioned approx. 5 - 10 mm below the concrete surface.  
 The effective embedment depth  $h_{ef}$  is calculated as follows when using the DD-S / DD-E clips.

$$h_{ef} = h_{nom} - h_{DD-E} - n \cdot h_{DD-S} \quad n = \text{number of DD-S clips used}$$

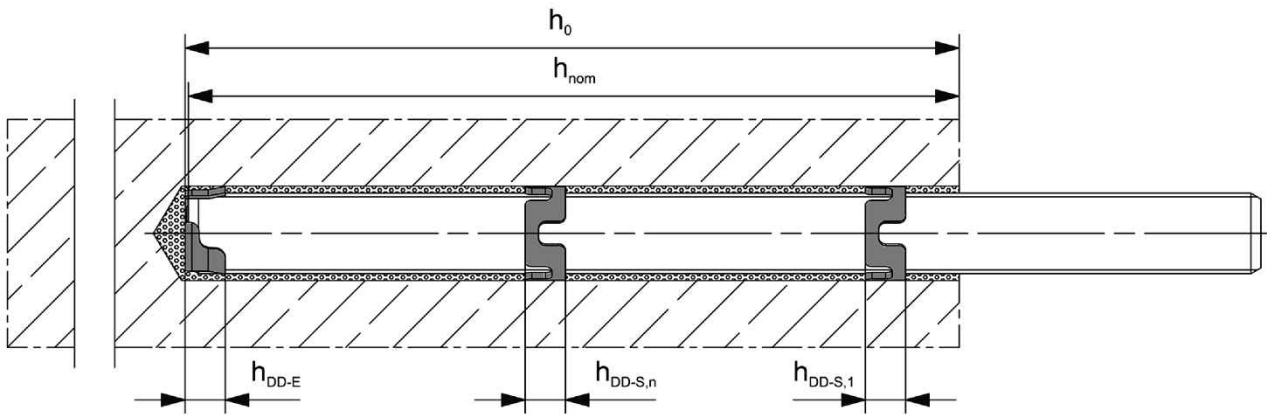

Figures not to scale

fischer injection system FIS V Plus

**Intended use**  
 fischer centering clip DD-S / DD-E

**Annex B11**

Appendix 20 / 41

# Installation instructions part 1

## Drilling and cleaning the hole (hammer drilling with standard drill bit)

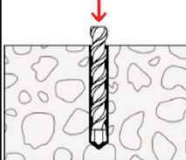
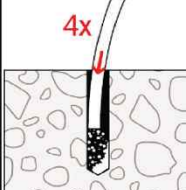
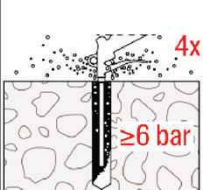
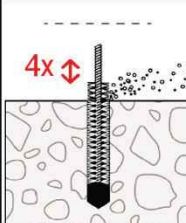
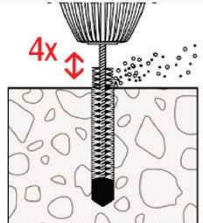
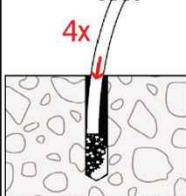
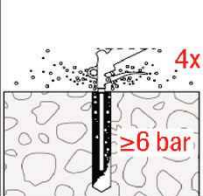
1		<p>Drill the hole. Nominal drill hole diameter <math>d_0</math> and drill hole depth <math>h_0</math> see <b>Tables B3.1, B4.1, B5.1, B6.1 or B7.1.</b></p>	
2		<p>Clean the drill hole: For <math>h_{ef} \leq 12d</math> and <math>d_0 &lt; 18</math> mm blow out the hole four times by hand.</p>	 <p>For <math>h_{ef} &gt; 12d</math> and / or <math>d_0 \geq 18</math> mm blow out the hole four times with oil-free compressed air (<math>p \geq 6</math> bar). Use suitable compressed-air nozzle</p>
3		<p>Brush the drill hole four times. For <math>d_0 &lt; 30</math> mm brush process can be performed by hand. For deep holes use an extension. Use suitable brushes (see <b>Table B10.1</b>).</p>	 <p>Brush the drill hole four times. For drill hole diameter <math>\geq 30</math> mm use a power drill. For deep holes use an extension. Use suitable brushes (see <b>Table B10.1</b>).</p>
4		<p>Clean the drill hole: For <math>h_{ef} \leq 12d</math> and <math>d_0 &lt; 18</math> mm blow out the hole four times by hand.</p>	 <p>For <math>h_{ef} &gt; 12d</math> and / or <math>d_0 \geq 18</math> mm blow out the hole four times with oil-free compressed air (<math>p \geq 6</math> bar). Use suitable compressed-air nozzle.</p>

Go to step 5

## Drilling and cleaning the hole (hammer drilling with hollow drill bit)

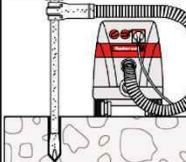
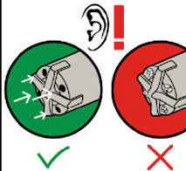
1		<p>Check a suitable hollow drill (see <b>Table B1.1</b>) for correct operation of the dust extraction.</p>
2		<p>Use a suitable dust extraction system, e.g. fischer FVC 35 M or a comparable dust extraction system with equivalent performance data Drill the hole with hollow drill bit. The dust extraction system has to extract the drill dust nonstop during the drilling process and must be adjusted to maximum power. Nominal drill hole diameter <math>d_0</math> and drill hole depth <math>h_0</math> see <b>Tables B3.1, B4.1, B5.1, B6.1, B7.1.</b></p>

Go to step 5

fischer injection system FIS V Plus

**Intended use**  
Installation instructions part 1

**Annex B12**

Appendix 21 / 41

# Installation instructions part 2

## Preparing the cartridge

5

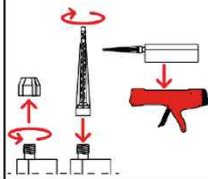

Remove the sealing cap  
Screw on the static mixer  
Place the cartridge into the dispenser

6

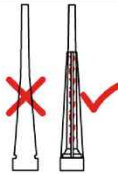

Ensuring that the spiral inside the mixer is clearly visible.

7



Extrude approximately 10 cm of material out until the resin is evenly grey in colour.  
Do not use mortar that is not uniformly grey.

Go to step 8

## Injection of the mortar

8

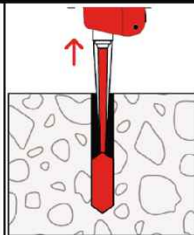

For  $h_0 = h_{ef}$  fill approximately 2/3 of the drill hole with mortar. For  $h_0 > h_{ef}$  more mortar is needed. Always begin from the bottom of the hole and avoid bubbles.

9

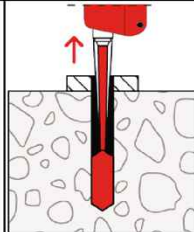

**Push-through installation:**  
the drill hole in the fixture must be also filled with mortar.

10

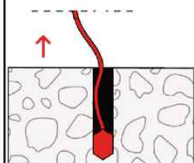

The conditions for mortar injection without extension tube can be found in **Table B10.3.**

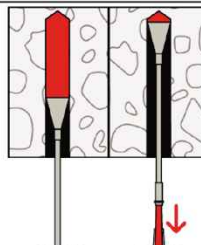

For overhead installation, deep holes ( $h_0 > 250$  mm) or drill hole diameter ( $d_0 \geq 30$  mm) use an injection-adapter.

Go to step 11

fischer injection system FIS V Plus

**Intended use**  
Installation instructions part 2

**Annex B13**

Appendix 22 / 41

### Installation instructions part 3

#### Installation of Anchor rods / Threaded rods, fischer RG M I and fischer FIS IG

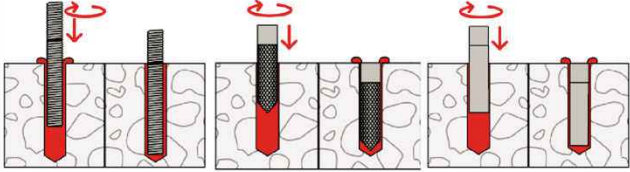
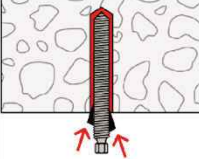
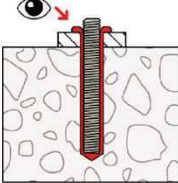
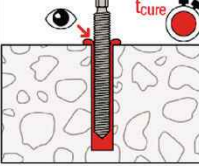
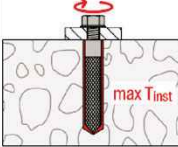
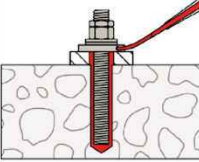
11		<p>Only use clean and oil-free metal parts. Push the Anchor rod / Threaded rods with the setting depth mark or fischer RG M I or fischer FIS IG down to the bottom of the hole, turning it slightly while doing so. No turning movement is permitted when using the DD-S / DD-E centering clips. After inserting the metal parts, excess mortar must be emerged around the anchor element.</p>
12	 <p>For overhead installations support the metal part with wedges (e.g. fischer centering wedges or fischer overhead clips).</p>	 <p>For push through installation fill the annular gap with mortar.</p>
13	 <p>Wait for the specified curing time <math>t_{cure}</math> see <b>Table B10.2</b>. The application with the anchor rod is shown as an example.</p>	 <p>14 Mounting the fixture <math>\max T_{inst}</math> see <b>Tables B3.1, B4.1 and B5.1</b>.</p>
Option	 <p>After the minimum curing time is reached, the gap between metal part and fixture (annular clearance) may be filled with mortar via the fischer filling disc. Compressive strength <math>\geq 50 \text{ N/mm}^2</math> (e.g. fischer injection mortars FIS HB, FIS SB, FIS V Plus, FIS EM Plus). ATTENTION: Using fischer filling disc reduces <math>t_{fix}</math> (usable length of the Anchor).</p>	

#### Installation reinforcing bars and fischer FRA

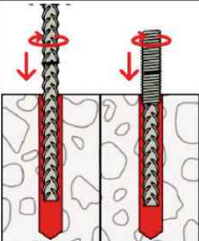
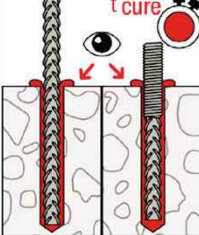
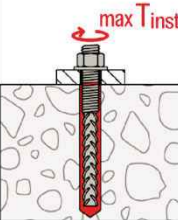
11	 <p>Only use clean and oil-free reinforcing bars or fischer FRA. Push the reinforcement bar or the fischer FRA with the setting depth mark into the filled hole up to the setting depth mark. Recommendation: Rotation back and forth of the reinforcement bar or the fischer FRA makes pushing easy.</p>	
12	 <p>When the setting depth mark is reached, excess mortar must be emerged from the mouth of the drill hole. Wait for the specified curing time <math>t_{cure}</math> see <b>Table B10.2</b>.</p>	 <p>12 Mounting the fixture <math>\max T_{inst}</math> see <b>Table B7.1</b>.</p>

fischer injection system FIS V Plus

**Intended use**  
Installation instructions part 3

**Annex B14**

Appendix 23 / 41

**Table C1.1: Characteristic resistance to steel failure under tension / shear loading of Anchor rods and Threaded rods**

Anchor rod / Threaded rod		M6	M8	M10	M12	M16	M20	M24	M27	M30			
<b>Characteristic resistance to steel failure under tension loading <sup>1)</sup></b>													
Characteristic resistance $N_{Rk,S}$	Steel zinc plated	Property class	4.8	[kN]	8,0	14,6(13,2)	23,2(21,4)	33,7	62,8	98,0	141,2	183,6	224,4
			5.8		10,1	18,3(16,6)	29,0(26,8)	42,1	78,5	122,5	176,5	229,5	280,5
			8.8		16,1	29,2(26,5)	46,4(42,8)	67,4	125,6	196,0	282,4	367,2	448,8
	Stainless steel R and high corrosion resistant steel HCR		50		10,1	18,3	29,0	42,1	78,5	122,5	176,5	229,5	280,5
			70		14,1	25,6	40,6	59,0	109,9	171,5	247,1	321,3	392,7
			80		16,1	29,2	46,4	67,4	125,6	196,0	282,4	367,2	448,8
<b>Partial factors <sup>1)</sup></b>													
Partial factor $\gamma_{Ms,N}$	Steel zinc plated	Property class	4.8	[-]	1,50								
			5.8		1,50								
			8.8		1,50								
	Stainless steel R and high corrosion resistant steel HCR		50		2,86								
			70		1.87 / fischer HCR: 1.50 <sup>3)</sup>								
			80		1,60								
<b>Characteristic resistance to steel failure under shear loading <sup>1)</sup></b>													
<b>without lever arm</b>													
Characteristic resistance $V_{Rk,S}$	Steel zinc plated	Property class	4.8	[kN]	4,8	8,7(7,9)	13,9(12,8)	20,2	37,6	58,8	84,7	110,1	134,6
			5.8		6,0	10,9(9,9)	17,4(16,0)	25,2	47,1	73,5	105,9	137,7	168,3
			8.8		8,0	14,6(13,2)	23,2(21,4)	33,7	62,8	98,0	141,2	183,6	224,4
	Stainless steel R and high corrosion resistant steel HCR		50		5,0	9,1	14,5	21,0	39,2	61,2	88,2	114,7	140,2
			70		7,0	12,8	20,3	29,5	54,9	85,7	123,5	160,6	196,3
			80		8,0	14,6	23,2	33,7	62,8	98,0	141,2	183,6	224,4
Ductility factor	k <sub>7</sub>	[-]	1,0										
<b>with lever arm</b>													
Characteristic resistance $M_{Rk,S}$	Steel zinc plated	Property class	4.8	[Nm]	6,1	14,9(12,9)	29,9(26,5)	52,3	132,9	259,6	448,8	665,7	899,5
			5.8		7,6	18,7(16,1)	37,3(33,2)	65,4	166,2	324,6	561,0	832,2	1124,4
			8.8		12,2	29,9(25,9)	59,8(53,1)	104,6	265,9	519,3	897,6	1331,5	1799,0
	Stainless steel R and high corrosion resistant steel HCR		50		7,6	18,7	37,3	65,4	166,2	324,6	561,0	832,2	1124,4
			70		10,7	26,2	52,3	91,5	232,6	454,4	785,4	1165,0	1574,1
			80		12,2	29,9	59,8	104,6	265,9	519,3	897,6	1331,5	1799,0
<b>Partial factors <sup>2)</sup></b>													
Partial factor $\gamma_{Ms,V}$	Steel zinc plated	Property class	4.8	[-]	1,25								
			5.8		1,25								
			8.8		1,25								
	Stainless steel R and high corrosion resistant steel HCR		50		2,38								
			70		1.56 / fischer HCR: 1.25 <sup>3)</sup>								
			80		1,33								

<sup>1)</sup> Values in brackets are valid for undersized threaded rods with smaller stress area  $A_s$  for hot dip galvanised threaded rods according to EN ISO 10684:2004+AC:2009.

<sup>2)</sup> In absence of other national regulations.

<sup>3)</sup> Only admissible for high corrosion resistant steel HCR, acc. to **Table A7.1**.

fischer injection system FIS V Plus

**Performances**

Characteristic resistance to steel failure under tension / shear loading of Anchor rods and Threaded rods

**Annex C1**

Appendix 24 / 41

<b>Table C2.1: Characteristic resistance to steel failure under tension / shear loading of fischer RG M I</b>									
<b>fischer RG M I</b>					<b>M8</b>	<b>M10</b>	<b>M12</b>	<b>M16</b>	<b>M20</b>
<b>Characteristic resistance to steel failure under tension loading</b>									
Characteristic resistance with Screw or Threaded / Anchor rod $N_{Rk,s}$	Steel zinc plated	Property class of Screw or Threaded / Anchor rod	5.8	[kN]	18,3	29,0	42,1	78,3	122,4
			8.8		29,2	46,4	67,4	106,7	180,2
	Stainless steel R and High corrosion resistant steel HCR		70		25,6	40,6	59,0	109,6	171,3
<b>Partial factors <sup>1)</sup></b>									
Partial factor $\gamma_{Ms,N}$	Steel zinc plated	Property class of Screw or Threaded / Anchor rod	5.8	[-]	1,50				
			8.8		1,50				
	Stainless steel R and High corrosion resistant steel HCR		70		1,87 / fischer HCR: 1,50 <sup>2)</sup>				
<b>Characteristic resistance to steel failure under shear loading</b>									
<b>Without lever arm</b>									
Characteristic resistance with Screw or Threaded / Anchor rod $V_{Rk,s}^0$	Steel zinc plated	Property class of Screw or Threaded / Anchor rod	5.8	[kN]	10,9	17,4	25,2	47,1	73,5
			8.8		14,6	23,2	33,7	62,8	98,0
	Stainless steel R and High corrosion resistant steel HCR		70		12,8	20,3	29,5	54,9	85,7
Ductility factor			$k_7$	[-]	1,0				
<b>With lever arm</b>									
Characteristic resistance with Screw or Threaded / Anchor rod $M_{Rk,s}^0$	Steel zinc plated	Property class of Screw or Threaded / Anchor rod	5.8	[Nm]	18,7	37,3	65,4	166,2	324,6
			8.8		29,9	59,8	104,6	265,9	519,3
	Stainless steel R and High corrosion resistant steel HCR		70		26,2	52,3	91,5	232,6	454,4
<b>Partial factors <sup>1)</sup></b>									
Partial factor $\gamma_{Ms,V}$	Steel zinc plated	Property class of Screw or Threaded / Anchor rod	5.8	[-]	1,25				
			8.8		1,25				
	Stainless steel R and High corrosion resistant steel HCR		70		1,56 / fischer HCR: 1,25 <sup>2)</sup>				
<sup>1)</sup> In absence of other national regulations <sup>2)</sup> Only admissible for high corrosion resistant steel HCR, acc. to <b>Table A7.1</b> .									
<b>fischer injection system FIS V Plus</b>								<b>Annex C2</b> Appendix 25 / 41	
<b>Performances</b> Characteristic resistance to steel failure under shear loading of fischer RG M I									

**Table C3.1: Characteristic resistance to steel failure under tension / shear loading of fischer FIS IG**

fischer FIS IG				M5	M6	M8	M10	M12	M16	M20	
<b>Characteristic resistance to steel failure under tension loading</b>											
Characteristic resistance with Screw or Threaded / Anchor rod $N_{Rk,s}$	Steel zinc plated	Property class of Screw or Threaded / Anchor rod	5.8	[kN]	7,1	10,1	18,3	29,0	42,1	78,3	122,4
			8.8		11,4	16,1	23,0	46,4	67,4	96,9	156,8
	Stainless steel R and High corrosion resistant steel HCR		70		9,9	14,1	25,6	40,6	59,0	109,6	171,3
<b>Partial factors <sup>1)</sup></b>											
Partial factor $\gamma_{Ms,N}$	Steel zinc plated	Property class of Screw or Threaded / Anchor rod	5.8	[-]	1,50						
			8.8		1,50						
	Stainless steel R and High corrosion resistant steel HCR		70		1,87 / fischer HCR: 1,50 <sup>2)</sup>						
<b>Characteristic resistance to steel failure under shear loading</b>											
<b>Without lever arm</b>											
Characteristic resistance with Screw or Threaded / Anchor rod $V_{Rk,s}$	Steel zinc plated	Property class of Screw or Threaded / Anchor rod	5.8	[kN]	4,3	6,0	10,9	17,4	25,2	47,1	73,5
			8.8		5,7	8,0	14,6	23,2	33,7	62,8	98,0
	Stainless steel R and High corrosion resistant steel HCR		70		5,0	7,0	12,8	20,3	29,5	54,9	85,7
Ductility factor			$k_7$	[-]	1,0						
<b>With lever arm</b>											
Characteristic resistance with Screw or Threaded / Anchor rod $M_{Rk,s}$	Steel zinc plated	Property class of Screw or Threaded / Anchor rod	5.8	[Nm]	4,5	7,6	18,7	37,3	65,4	166,2	324,6
			8.8		7,2	12,2	29,9	59,8	104,6	265,9	519,3
	Stainless steel R and High corrosion resistant steel HCR		70		6,3	10,7	26,2	52,3	91,5	232,6	454,4
<b>Partial factors <sup>1)</sup></b>											
Partial factor $\gamma_{Ms,V}$	Steel zinc plated	Property class of Screw or Threaded / Anchor rod	5.8	[-]	1,25						
			8.8		1,25						
	Stainless steel R and High corrosion resistant steel HCR		70		1,56 / fischer HCR: 1,25 <sup>2)</sup>						

<sup>1)</sup> In absence of other national regulations.

<sup>2)</sup> Only admissible for high corrosion resistant steel HCR, acc. to **Table A7.1**

fischer injection system FIS V Plus

**Performances**  
Characteristic resistance to steel failure under shear loading of fischer FIS IG

**Annex C3**

Appendix 26 / 41

**Table C4.1: Characteristic resistance to steel failure under tension / shear loading of reinforcing bars**

Nominal diameter of the bar	$\phi$	8	10	12	14	16	20	25	28
<b>Characteristic resistance to steel failure under tension loading</b>									
Characteristic resistance	$N_{Rk,s}$	[kN]	$A_s \cdot f_{uk}^{1)}$						
<b>Characteristic resistance to steel failure under shear loading</b>									
<b>Without lever arm</b>									
Characteristic resistance	$V^0_{Rk,s}$	[kN]	$k_6^{2)}) \cdot A_s \cdot f_{uk}^{1)}$						
Ductility factor	$k_7$	[-]	1,0						
<b>With lever arm</b>									
Characteristic resistance	$M^0_{Rk,s}$	[Nm]	$1,2 \cdot W_{el} \cdot f_{uk}^{1)}$						
<p><sup>1)</sup> <math>f_{uk}</math> respectively shall be taken from the specifications of the reinforcing bar.  <sup>2)</sup> In accordance with EN 1992-4:2018 section 7.2.2.3.1:  <math>k_6 = 0,6</math> for fasteners made of carbon steel with <math>f_{uk} \leq 500 \text{ N/mm}^2</math>,  <math>= 0,5</math> for fasteners made of carbon steel with <math>500 \text{ N/mm}^2 &lt; f_{uk} \leq 1000 \text{ N/mm}^2</math>,  <math>= 0,5</math> for fasteners made of stainless steel.</p>									

**Table C4.2: Characteristic resistance to steel failure under tension / shear loading of fischer FRA**

fischer FRA		M12	M16	M20	M24	
<b>Characteristic resistance to steel failure under tension loading</b>						
Characteristic resistance	$N_{Rk,s}$	[kN]	62,0	111,0	173,0	236,5
<b>Partial factor<sup>1)</sup></b>						
Partial factor	$\gamma_{Ms,N}$	[-]	1,4			
<b>Characteristic resistance to steel failure under shear loading</b>						
<b>Without lever arm</b>						
Characteristic resistance	$V^0_{Rk,s}$	[kN]	34,5	64,3	100,4	144,7
Ductility factor	$k_7$	[-]	1,0			
<b>With lever arm</b>						
Characteristic resistance	$M^0_{Rk,s}$	[Nm]	107,4	273,0	532,2	920,4
<b>Partial factor<sup>1)</sup></b>						
Partial factor	$\gamma_{Ms,V}$	[-]	1,5			

<sup>1)</sup> In absence of other national regulations.

<b>Table C5.1: Characteristic resistance to concrete failure under tension / shear loading</b>													
<b>Size</b>			<b>All sizes</b>										
<b>Characteristic resistance to concrete failure under tension loading</b>													
Installation factor		$\gamma_{inst}$	[-]		See annex C6 to C11 and C 17 to C18								
<b>Factors for the compressive strength of concrete &gt; C20/25</b>													
Increasing factor $\psi_c$ for cracked or uncracked concrete $\tau_{RK(X,Y)} = \psi_c \cdot \tau_{RK(C20/25)}$	C25/30		[-]	1,05									
	C30/37			1,10									
	C35/45			1,15									
	C40/50			1,19									
	C45/55			1,22									
	C50/60			1,26									
<b>Splitting failure</b>													
Edge distance	$h / h_{ef} \geq 2,0$		$C_{cr,sp}$	[mm]	1,0 $h_{ef}$				C12/15: 1,22 $h_{ef}$				
	$2,0 > h / h_{ef} > 1,3$				4,6 $h_{ef}$ - 1,8 h				C12/15: 5,6 $h_{ef}$ - 2,2 h				
	$h / h_{ef} \leq 1,3$				2,26 $h_{ef}$				C12/15: 2,75 $h_{ef}$				
Spacing		$S_{cr,sp}$	$2 C_{cr,sp}$										
<b>Concrete failure</b>													
Uncracked concrete		$k_{ucr,N}$	[-]	11,0									
Cracked concrete		$k_{cr,N}$		7,7									
Edge distance		$C_{cr,N}$	[mm]	1,5 $h_{ef}$									
Spacing		$S_{cr,N}$		$2 C_{cr,N}$									
<b>Factors for sustained tension loading</b>													
Temperature range			[-]		50 °C / 80 °C				72 °C / 120 °C				
Factor C12/15 and C16/20		$\Psi_{sus}^0$	[-]		0,68				0,70				
Factor from $\geq$ C20/25		$\Psi_{sus}^0 = \Psi_{sus,100}^0$	[-]		0,76				0,78				
<b>Characteristic resistance to concrete failure under shear loading</b>													
Installation factor		$\gamma_{inst}$	[-]		1,0								
<b>Concrete pry-out failure</b>													
Factor for pry-out failure		$k_8$	[-]		2,0								
<b>Concrete edge failure</b>													
Effective length of fastener in shear loading		$l_f$	[mm]	for $d_{nom} \leq 24$ mm: min ( $h_{ef}$ ; 12 $d_{nom}$ ) for $d_{nom} > 24$ mm: min ( $h_{ef}$ ; 8 $d_{nom}$ ; 300 mm)									
<b>Calculation diameters</b>													
Size			M5	M6	M8	M10	M12	M16	M20	M24	M27	M30	
Anchor rods and Threaded rods		$d_{nom}$	[mm]	-1)	6	8	10	12	16	20	24	27	30
fischer RG M I		$d_{nom}$		-1)	-1)	12	16	18	22	28	-1)	-1)	-1)
fischer FIS IG		$d_{nom}$		8	10	12	16	20	24	30	-1)	-1)	-1)
fischer FRA		$d_{nom}$		-1)	-1)	-1)	-1)	12	16	20	25	-1)	-1)
Size (nominal diameter of the bar)			$\phi$	8	10	12	14	16	20	25	28		
Reinforcing bar		$d_{nom}$	[mm]	8	10	12	14	16	20	25	28		
1) Size of Anchor type not part of the assessment													
fischer injection system FIS V Plus									<b>Annex C5</b> Appendix 28 / 41				
<b>Performances</b> Characteristic resistance to concrete failure under tension / shear loading													

**Table C6.1: Characteristic resistance to combined pull-out and concrete failure for Anchor rods and Threaded rods and fischer FIS IG in hammer drilled holes; uncracked or cracked concrete C20/25; working life 50 years**

Anchor rod / Threaded rod		M6	M8	M10	M12	M16	M20	M24	M27	M30			
fischer FIS IG		-	-	M5 M6	M8	M10	M12	M16	-	M20			
<b>Combined pullout and concrete cone failure</b>													
Calculation diameter	d	[mm]	6	8	10	12	16	20	24	27	30		
<b>Uncracked concrete</b>													
<b>Characteristic bond resistance in uncracked concrete C20/25</b>													
Hammer-drilling with standard drill bit or hollow drill bit (dry or wet concrete)													
Temperature range	I: 50 °C / 80 °C		$\tau_{Rk,ucr}$	[N/mm <sup>2</sup> ]	9,0	16,0	16,0	15,0	14,0	12,0	11,0	10,0	9,0
	II: 72 °C / 120 °C				6,5	15,0	14,0	13,0	12,0	11,0	9,0	8,0	8,0
Hammer-drilling with standard drill bit or hollow drill bit (water filled hole)													
Temperature range	I: 50 °C / 80 °C		$\tau_{Rk,ucr}$	[N/mm <sup>2</sup> ]	-1)	-1)	-1)	9,5	8,5	8,0	7,5	7,0	7,0
	II: 72 °C / 120 °C				-1)	-1)	-1)	7,5	7,0	6,5	6,0	6,0	6,0
<b>Installation factors</b>													
Dry or wet concrete	$\gamma_{inst}$	[-]	1,0										
Water filled hole	$\gamma_{inst}$	[-]	-1)	-1)	-1)	1,2							
<b>Cracked concrete</b>													
<b>Characteristic bond resistance in cracked concrete C20/25</b>													
Hammer-drilling with standard drill bit or hollow drill bit (dry or wet concrete)													
Temperature range	I: 50 °C / 80 °C		$\tau_{Rk,cr}$	[N/mm <sup>2</sup> ]	-1)	5,5	6,0	6,5	6,0	5,5	5,0	5,0	4,5
	II: 72 °C / 120 °C				-1)	4,5	5,0	6,0	5,5	5,0	4,5	4,0	4,0
Hammer-drilling with standard drill bit or hollow drill bit (water filled hole)													
Temperature range	I: 50 °C / 80 °C		$\tau_{Rk,cr}$	[N/mm <sup>2</sup> ]	-1)	-1)	-1)	5,0	5,0	4,5	4,0	3,5	3,5
	II: 72 °C / 120 °C				-1)	-1)	-1)	4,0	4,0	4,0	3,5	3,0	3,0
<b>Installation factors</b>													
Dry or wet concrete	$\gamma_{inst}$	[-]	-1)	1,0									
Water filled hole	$\gamma_{inst}$	[-]	-1)	-1)	-1)	1,2							
1) No performance assessed													
fischer injection system FIS V Plus								<b>Annex C6</b> Appendix 29 / 41					
<b>Performances</b> Characteristic resistance to combined pull-out and concrete failure for Anchor rod and Threaded rods; working life 50 years; concrete C20/25													

**Table C7.1: Characteristic resistance to combined pull-out and concrete failure for Anchor rods, Threaded rods and fischer FIS IG in hammer drilled holes; uncracked or cracked concrete C20/25; working life 100 years**

Anchor rod / Threaded rod		M6	M8	M10	M12	M16	M20	M24	M27	M30	
fischer FIS IG		-	-	M5 M6	M8	M10	M12	M16	-	M20	
<b>Combined pullout and concrete cone failure</b>											
Calculation diameter	d	[mm]	6	8	10	12	16	20	24	27	30
<b>Uncracked concrete</b>											
<b>Characteristic bond resistance in uncracked concrete C20/25</b>											
<u>Hammer-drilling with standard drill bit or hollow drill bit (dry or wet concrete)</u>											
Temperature range	I: 50 °C / 80 °C	$\tau_{Rk,100,ucr}$ [N/mm <sup>2</sup> ]	- <sup>1)</sup>	16,0	16,0	15,0	14,0	12,0	11,0	10,0	9,0
	II: 72 °C / 120 °C		- <sup>1)</sup>	15,0	14,0	13,0	12,0	11,0	9,0	8,0	8,0
<u>Hammer-drilling with standard drill bit or hollow drill bit (water filled hole)</u>											
Temperature range	I: 50 °C / 80 °C	$\tau_{Rk,100,ucr}$ [N/mm <sup>2</sup> ]	- <sup>1)</sup>	- <sup>1)</sup>	- <sup>1)</sup>	9,5	8,5	8,0	7,5	7,0	7,0
	II: 72 °C / 120 °C		- <sup>1)</sup>	- <sup>1)</sup>	- <sup>1)</sup>	7,5	7,0	6,5	6,0	6,0	6,0
<b>Installation factors</b>											
Dry or wet concrete	$\gamma_{inst}$	[-]	- <sup>1)</sup>	1,0							
Water filled hole			- <sup>1)</sup>	- <sup>1)</sup>	- <sup>1)</sup>	1,2					
<b>Cracked concrete</b>											
<b>Characteristic bond resistance in cracked concrete C20/25</b>											
<u>Hammer-drilling with standard drill bit or hollow drill bit (dry or wet concrete)</u>											
Temperature range	I: 50 °C / 80 °C	$\tau_{Rk,100,cr}$ [N/mm <sup>2</sup> ]	- <sup>1)</sup>	5,0	5,5	5,5	5,5	5,5	5,0	5,0	4,5
	II: 72 °C / 120 °C		- <sup>1)</sup>	4,5	5,0	5,0	5,0	5,0	4,0	4,0	4,0
<u>Hammer-drilling with standard drill bit or hollow drill bit (water filled hole)</u>											
Temperature range	I: 50 °C / 80 °C	$\tau_{Rk,100,cr}$ [N/mm <sup>2</sup> ]	- <sup>1)</sup>	- <sup>1)</sup>	- <sup>1)</sup>	4,5	4,5	4,5	4,0	3,5	3,5
	II: 72 °C / 120 °C		- <sup>1)</sup>	- <sup>1)</sup>	- <sup>1)</sup>	4,0	4,0	4,0	3,5	3,0	3,0
<b>Installation factors</b>											
Dry or wet concrete	$\gamma_{inst}$	[-]	- <sup>1)</sup>	1,0							
Water filled hole			- <sup>1)</sup>	- <sup>1)</sup>	- <sup>1)</sup>	1,2					
<sup>1)</sup> No performance assessed											

fischer injection system FIS V Plus

**Performances**

Characteristic resistance to combined pull-out and concrete failure for Anchor rod and Threaded rods; working life 100 years; concrete C20/25

**Annex C7**

Appendix 30 / 41

**Table C8.1: Characteristic resistance to combined pull-out and concrete failure for Anchor rods, Threaded rods and fischer FIS IG in hammer drilled holes; uncracked or cracked concrete C12/15 and C16/20; working life 50 years**

Anchor rod / Threaded rod		M6	M8	M10	M12	M16	M20	M24	M27	M30			
fischer FIS IG		-	-	M5 M6	M8	M10	M12	M16	-	M20			
<b>Combined pullout and concrete cone failure</b>													
Calculation diameter	d	[mm]	6	8	10	12	16	20	24	27	30		
<b>Uncracked concrete</b>													
<b>Characteristic bond resistance in uncracked concrete C12/15</b>													
Hammer-drilling with standard drill bit or hollow drill bit (dry or wet concrete)													
Tem- perature range	I: 50 °C / 80 °C		$\tau_{Rk,ucr}$	[N/mm <sup>2</sup> ]	- <sup>1)</sup>	12,5	12	11,5	10,5	10,0	9,0	8,5	8,0
	II: 72 °C / 120 °C				- <sup>1)</sup>	9,5	9,0	8,5	8,0	7,5	7,0	6,5	6,5
Hammer-drilling with standard drill bit or hollow drill bit (water filled hole)													
Tem- perature range	I: 50 °C / 80 °C		$\tau_{Rk,ucr}$	[N/mm <sup>2</sup> ]	- <sup>1)</sup>	- <sup>1)</sup>	- <sup>1)</sup>	9,0	7,5	7,0	4,0	3,5	3,5
	II: 72 °C / 120 °C				- <sup>1)</sup>	- <sup>1)</sup>	- <sup>1)</sup>	7,0	6,0	5,5	3,0	3,0	2,5
<b>Installation factors</b>													
Dry or wet concrete		$\gamma_{inst}$	[-]	- <sup>1)</sup>	1,2								
Water filled hole				- <sup>1)</sup>	1,4								
<b>Cracked concrete</b>													
<b>Characteristic bond resistance in cracked concrete C12/15</b>													
Hammer-drilling with standard drill bit or hollow drill bit (dry or wet concrete)													
Tem- perature range	I: 50 °C / 80 °C		$\tau_{Rk,cr}$	[N/mm <sup>2</sup> ]	- <sup>1)</sup>	4,5	5,0	5,0	5,0	4,0	4,0	4,0	4,0
	II: 72 °C / 120 °C				- <sup>1)</sup>	3,5	3,5	3,5	3,5	3,0	3,0	3,0	3,0
Hammer-drilling with standard drill bit or hollow drill bit (water filled hole)													
Tem- perature range	I: 50 °C / 80 °C		$\tau_{Rk,cr}$	[N/mm <sup>2</sup> ]	- <sup>1)</sup>	- <sup>1)</sup>	- <sup>1)</sup>	4,0	3,5	3,0	2,0	2,0	2,0
	II: 72 °C / 120 °C				- <sup>1)</sup>	- <sup>1)</sup>	- <sup>1)</sup>	3,0	2,5	2,5	1,5	1,5	1,5
<b>Installation factors</b>													
Dry or wet concrete		$\gamma_{inst}$	[-]	- <sup>1)</sup>	1,2								
Water filled hole				- <sup>1)</sup>	1,4								

<sup>1)</sup> No performance assessed

fischer injection system FIS V Plus

**Performances**

Characteristic resistance to combined pull-out and concrete failure for Anchor rod and Threaded rods; working life 50 years; concrete C12/15

**Annex C8**

Appendix 31 / 41

**Table C9.1: Characteristic resistance to combined pull-out and concrete failure for fischer RG M I in hammer drilled holes; uncracked concrete; working life 50 years**

fischer RG M I		M8	M10	M12	M16	M20	
<b>Combined pullout and concrete cone failure</b>							
Calculation diameter	d [mm]	12	16	18	22	28	
<b>Uncracked concrete</b>							
<b>Characteristic bond resistance in uncracked concrete C20/25</b>							
<u>Hammer-drilling with standard drill bit or hollow drill bit (dry or wet concrete)</u>							
Temperature range	I: 50 °C / 80 °C	$\tau_{Rk,ucr}$ [N/mm <sup>2</sup> ]	10,5	10,0	9,5	9,0	8,5
	II: 72 °C / 120 °C		9,0	8,0	8,0	7,5	7,0
<u>Hammer-drilling with standard drill bit or hollow drill bit (water filled hole)</u>							
Temperature range	I: 50 °C / 80 °C	$\tau_{Rk,ucr}$ [N/mm <sup>2</sup> ]	10,0	9,0	9,0	8,5	8,0
	II: 72 °C / 120 °C		7,5	6,5	6,5	6,0	6,0
<b>Installation factors</b>							
Dry or wet concrete	$\gamma_{inst}$	[-]	1,0				
Water filled hole			1,2				



**Table C10.1: Characteristic resistance to combined pull-out and concrete failure for reinforcing bars in hammer drilled holes; uncracked or cracked concrete; working life 50 years**

<b>Nominal diameter of the bar</b>		$\phi$	<b>8</b>	<b>10</b>	<b>12</b>	<b>14</b>	<b>16</b>	<b>20</b>	<b>25</b>	<b>28</b>		
<b>Combined pullout and concrete cone failure</b>												
Calculation diameter		d	[mm]	8	10	12	14	16	20	25	28	
<b>Uncracked concrete</b>												
<b>Characteristic bond resistance in uncracked concrete C20/25</b>												
Hammer-drilling with standard drill bit or hollow drill bit (dry or wet concrete)												
Tem- perature range	I: 50 °C / 80 °C		$\tau_{Rk,ucr}$	[N/mm <sup>2</sup> ]	11,0	11,0	11,0	10,0	10,0	9,5	9,0	8,5
	II: 72 °C / 120 °C				9,5	9,5	9,0	8,5	8,5	8,0	7,5	7,0
<b>Installation factor</b>												
Dry or wet concrete		$\gamma_{inst}$	[-]	1,0								
<b>Cracked concrete</b>												
<b>Characteristic bond resistance in cracked concrete C20/25</b>												
Hammer-drilling with standard drill bit or hollow drill bit (dry or wet concrete)												
Tem- perature range	I: 50 °C / 80 °C		$\tau_{Rk,cr}$	[N/mm <sup>2</sup> ]	- <sup>1)</sup>	3,0	5,0	5,0	5,0	4,5	4,0	4,0
	II: 72 °C / 120 °C				- <sup>1)</sup>	3,0	4,5	4,5	4,5	4,0	3,5	3,5
<b>Installation factor</b>												
Dry or wet concrete		$\gamma_{inst}$	[-]	1,0								

<sup>1)</sup> No performance assessed

fischer injection system FIS V Plus

**Performances**

Characteristic resistance to combined pull-out and concrete failure for reinforcing bars; working life 50 years

**Annex C10**

Appendix 33 / 41

**Table C11.1: Characteristic resistance to combined pull-out and concrete failure for fischer FRA in hammer drilled holes; uncracked or cracked concrete; working life 50 years**

fischer FRA		M12	M16	M20	M24	
<b>Combined pullout and concrete cone failure</b>						
Calculation diameter	d [mm]	12	16	20	25	
<b>Uncracked concrete</b>						
<b>Characteristic bond resistance in uncracked concrete C20/25</b>						
<u>Hammer-drilling with standard drill bit or hollow drill bit (dry or wet concrete)</u>						
Temperature range	I: 50 °C / 80 °C	$\tau_{Rk,ucr}$ [N/mm <sup>2</sup> ]	11,0	10,0	9,5	9,5
	II: 72 °C / 120 °C		9,0	8,5	8,0	7,5
<b>Installation factors</b>						
Dry or wet concrete	$\gamma_{inst}$	[-]	1,0			
<b>Cracked concrete</b>						
<b>Characteristic bond resistance in cracked concrete C20/25</b>						
<u>Hammer-drilling with standard drill bit or hollow drill bit (dry or wet concrete)</u>						
Temperature range	I: 50 °C / 80 °C	$\tau_{Rk,cr}$ [N/mm <sup>2</sup> ]	5,0	5,0	4,5	4,0
	II: 72 °C / 120 °C		4,5	4,5	4,0	3,5
<b>Installation factors</b>						
Dry or wet concrete	$\gamma_{inst}$	[-]	1,0			

fischer injection system FIS V Plus

**Performances**

Characteristic resistance to combined pull-out and concrete failure for fischer FRA; working life 50 years

**Annex C11**

Appendix 34 / 41

**Table C12.1: Displacements for Anchor rods / Threaded rods or fischer FIS IG**

Anchor rod / Threaded rods		M6	M8	M10	M12	M16	M20	M24	M27	M30
fischer FIS IG										
<b>Displacement-Factors for tension loading<sup>1)</sup></b>										
<b>Uncracked concrete; Temperature range I, II</b>										
$\delta_{N0}$ -Factor	[mm/(N/mm <sup>2</sup> )]	0,09	0,09	0,09	0,10	0,10	0,10	0,10	0,12	0,12
$\delta_{N\infty}$ -Factor		0,10	0,10	0,10	0,12	0,12	0,12	0,12	0,13	0,13
<b>Cracked concrete; Temperature range I, II</b>										
$\delta_{N0}$ -Factor	[mm/(N/mm <sup>2</sup> )]	- <sup>3)</sup>	0,12	0,12	0,12	0,13	0,16	0,19	0,21	0,23
$\delta_{N\infty}$ -Factor		- <sup>3)</sup>	0,25	0,27	0,30	0,30	0,30	0,35	0,35	0,40
<b>Displacement-Factors for shear loading<sup>2)</sup></b>										
<b>Uncracked or cracked concrete; Temperature range I, II</b>										
$\delta_{V0}$ -Factor	[mm/kN]	0,11	0,11	0,11	0,10	0,10	0,09	0,09	0,08	0,07
$\delta_{V\infty}$ -Factor		0,12	0,12	0,12	0,11	0,11	0,10	0,10	0,09	0,09
1) Calculation of effective displacement: $\delta_{N0} = \delta_{N0}\text{-Factor} \cdot \tau$ $\delta_{N\infty} = \delta_{N\infty}\text{-Factor} \cdot \tau$ $\tau$ = acting bond strength under tension loading					2) Calculation of effective displacement: $\delta_{V0} = \delta_{V0}\text{-Factor} \cdot V$ $\delta_{V\infty} = \delta_{V\infty}\text{-Factor} \cdot V$ $V$ = acting shear loading					
3) No performance assessed										

**Table C12.2: Displacements for fischer RG M I**

fischer RG M I		M8	M10	M12	M16	M20
<b>Displacement-Factors for tension loading<sup>1)</sup></b>						
<b>Uncracked concrete; Temperature range I, II</b>						
$\delta_{N0}$ -Factor	[mm/(N/mm <sup>2</sup> )]	0,10	0,11	0,12	0,13	0,14
$\delta_{N\infty}$ -Factor		0,13	0,14	0,15	0,16	0,18
<b>Displacement-Factors for shear loading<sup>2)</sup></b>						
<b>Uncracked concrete; Temperature range I, II</b>						
$\delta_{V0}$ -Factor	[mm/kN]	0,12	0,12	0,12	0,12	0,12
$\delta_{V\infty}$ -Factor		0,14	0,14	0,14	0,14	0,14
1) Calculation of effective displacement: $\delta_{N0} = \delta_{N0}\text{-Factor} \cdot \tau$ $\delta_{N\infty} = \delta_{N\infty}\text{-Factor} \cdot \tau$ $\tau$ = acting bond strength under tension loading			2) Calculation of effective displacement: $\delta_{V0} = \delta_{V0}\text{-Factor} \cdot V$ $\delta_{V\infty} = \delta_{V\infty}\text{-Factor} \cdot V$ $V$ : acting shear loading			

fischer injection system FIS V Plus	<b>Annex C12</b> Appendix 35 / 41
<b>Performances</b> Displacements for Anchor rods / Threaded rods, fischer FIS IG and fischer RG M I	

**Table C13.1: Displacements for reinforcing bars**

Nominal diameter of the bar $\phi$		8	10	12	14	16	20	25	28
<b>Displacement-Factors for tension loading<sup>1)</sup></b>									
<b>Uncracked concrete; Temperature range I, II</b>									
$\delta_{N0}$ -Factor	[mm/(N/mm <sup>2</sup> )]	0,09	0,09	0,10	0,10	0,10	0,10	0,10	0,11
$\delta_{N\infty}$ -Factor		0,10	0,10	0,12	0,12	0,12	0,12	0,12	0,13
<b>Cracked concrete; Temperature range I, II</b>									
$\delta_{N0}$ -Factor	[mm/(N/mm <sup>2</sup> )]	- <sup>3)</sup>	0,12	0,13	0,13	0,13	0,13	0,13	0,14
$\delta_{N\infty}$ -Factor		- <sup>3)</sup>	0,27	0,30	0,30	0,30	0,30	0,30	0,35
<b>Displacement-Factors for shear loading<sup>2)</sup></b>									
<b>Uncracked or cracked concrete; Temperature range I, II</b>									
$\delta_{V0}$ -Factor	[mm/kN]	0,11	0,11	0,10	0,10	0,10	0,09	0,09	0,08
$\delta_{V\infty}$ -Factor		0,12	0,12	0,11	0,11	0,11	0,10	0,10	0,09
1) Calculation of effective displacement: $\delta_{N0} = \delta_{N0}\text{-Factor} \cdot \tau$ $\delta_{N\infty} = \delta_{N\infty}\text{-Factor} \cdot \tau$ $\tau$ = acting bond strength under tension loading <sup>3)</sup> No performance assessed					2) Calculation of effective displacement: $\delta_{V0} = \delta_{V0}\text{-Factor} \cdot V$ $\delta_{V\infty} = \delta_{V\infty}\text{-Factor} \cdot V$ V: acting shear loading				

**Table C13.2: Displacements for fischer FRA**

fischer FRA		M12	M16	M20	M24
<b>Displacement-Factors for tension loading<sup>1)</sup></b>					
<b>Uncracked concrete; Temperature range I, II</b>					
$\delta_{N0}$ -Factor	[mm/(N/mm <sup>2</sup> )]	0,10	0,10	0,10	0,10
$\delta_{N\infty}$ -Factor		0,12	0,12	0,12	0,13
<b>Cracked concrete; Temperature range I, II</b>					
$\delta_{N0}$ -Factor	[mm/(N/mm <sup>2</sup> )]	0,12	0,13	0,13	0,13
$\delta_{N\infty}$ -Factor		0,30	0,30	0,30	0,35
<b>Displacement-Factors for shear loading<sup>2)</sup></b>					
<b>Uncracked or cracked concrete; Temperature range I, II</b>					
$\delta_{V0}$ -Factor	[mm/kN]	0,10	0,10	0,09	0,09
$\delta_{V\infty}$ -Factor		0,11	0,11	0,10	0,10
1) Calculation of effective displacement: $\delta_{N0} = \delta_{N0}\text{-Factor} \cdot \tau$ $\delta_{N\infty} = \delta_{N\infty}\text{-Factor} \cdot \tau$ $\tau$ = acting bond strength under tension loading			2) Calculation of effective displacement: $\delta_{V0} = \delta_{V0}\text{-Factor} \cdot V$ $\delta_{V\infty} = \delta_{V\infty}\text{-Factor} \cdot V$ V: acting shear loading		

fischer injection system FIS V Plus	<b>Annex C13</b> Appendix 36 / 41
<b>Performances</b> Displacements for reinforcing bars and fischer FRA	

**Table C14.1:** Characteristic resistance to **steel failure under tension / shear loading of Anchor rods and Threaded rods** under seismic action performance category **C1**

Anchor rod / Threaded rod		M10	M12	M16	M20	M24	M27	M30		
<b>Characteristic resistance to steel failure under tension loading <sup>1)</sup></b>										
<b>Anchor rods and Threaded rods, performance category C1 <sup>2)</sup></b>										
Characteristic resistance $N_{Rk,s,C1}$	Steel zinc plated	Property class	4.8	23,2(21,4)	33,7	62,8	98,0	141,2	183,6	224,4
			5.8	29,0(26,8)	42,1	78,5	122,5	176,5	229,5	280,5
			8.8	46,4(42,8)	67,4	125,6	196,0	282,4	367,2	448,8
	Stainless steel R and high corrosion resistant steel HCR		50	29,0	42,1	78,5	122,5	176,5	229,5	280,5
			70	40,6	59,0	109,9	171,5	247,1	321,3	392,7
			80	46,4	67,4	125,6	196,0	282,4	367,2	448,8
<b>Characteristic resistance to steel failure under shear loading without lever arm <sup>1)</sup></b>										
<b>Anchor rods, performance category C1 <sup>2)</sup></b>										
Characteristic resistance $V_{Rk,s,C1}$	Steel zinc plated	Property class	4.8	13,9(12,8)	20,2	37,6	58,8	84,7	110,1	134,6
			5.8	17,4(16,0)	25,2	47,1	73,5	105,9	137,7	168,3
			8.8	23,2(21,4)	33,7	62,8	98,0	141,2	183,6	224,4
	Stainless steel R and high corrosion resistant steel HCR		50	14,5	21,0	39,2	61,2	88,2	114,7	140,2
			70	20,3	29,5	54,9	85,7	123,5	160,6	196,3
			80	23,2	33,7	62,8	98,0	141,2	183,6	224,4
<b>Threaded rods, performance category C1 <sup>2)</sup></b>										
Characteristic resistance $V_{Rk,s,C1}$	Steel zinc plated	Property class	4.8	9,7(9,0)	14,1	26,3	41,1	59,3	77,1	97,2
			5.8	12,1(11,2)	17,7	32,9	51,4	74,1	96,3	117,8
			8.8	16,2(15,0)	23,6	43,9	68,6	98,8	128,5	157,0
	Stainless steel R and high corrosion resistant steel HCR		50	10,1	14,7	27,4	42,8	61,7	80,3	98,1
			70	14,2	20,6	38,4	60,0	86,4	112,4	137,4
			80	16,2	23,6	43,9	68,6	98,8	128,5	157,0

<sup>1)</sup> Values in brackets are valid for undersized Threaded rods with smaller stress area  $A_s$  for hot dip galvanised Threaded rods according to EN ISO 10684:2004+AC:2009.

<sup>2)</sup> Partial factors for performance category C1 see **Table C16.1**; for Anchor rods the factor for steel ductility is 1,0

fischer injection system FIS V Plus

**Performances**

Characteristic resistance to steel failure under tension / shear loading for Anchor rods and Threaded rods under seismic action (performance category C1)

**Annex C14**

Appendix 37 / 41

**Table C15.1: Characteristic resistance to steel failure under tension / shear loading for Anchor rods and Threaded rods under seismic action performance category C2**

Anchor rod / Threaded rod		M10	M12	M16	M20	M24	M27	M30		
<b>Characteristic resistance to steel failure under tension loading</b>										
<b>Anchor rods and Threaded rods, performance category C2 <sup>1)</sup></b>										
Characteristic resistance $N_{Rk,s,C2}$	Steel zinc plated	Property class	4.8	-2)	30,3	56,5	88,2	-2)	-2)	-2)
			5.8	-2)	37,9	70,6	110,2	-2)	-2)	-2)
			8.8	-2)	60,6	113,0	176,4	-2)	-2)	-2)
	Stainless steel R and high corrosion resistant steel HCR	Property class	50	-2)	37,9	70,6	110,2	-2)	-2)	-2)
			70	-2)	53,1	98,9	154,3	-2)	-2)	-2)
			80	-2)	60,6	113,0	176,4	-2)	-2)	-2)
<b>Characteristic resistance to steel failure under shear loading without lever arm</b>										
<b>Anchor rods, performance category C2 <sup>1)</sup></b>										
Characteristic resistance $V_{Rk,s,C2}$	Steel zinc plated	Property class	4.8	-2)	13,3	28,2	45,2	-2)	-2)	-2)
			5.8	-2)	16,6	35,3	56,5	-2)	-2)	-2)
			8.8	-2)	22,2	47,1	75,4	-2)	-2)	-2)
	Stainless steel R and high corrosion resistant steel HCR	Property class	50	-2)	13,9	29,4	47,1	-2)	-2)	-2)
			70	-2)	19,4	41,2	66,0	-2)	-2)	-2)
			80	-2)	22,2	47,1	75,4	-2)	-2)	-2)
<b>Threaded rods, performance category C2 <sup>1)</sup></b>										
Characteristic resistance $V_{Rk,s,C2}$	Steel zinc plated	Property class	4.8	-2)	13,3	26,3	41,1	-2)	-2)	-2)
			5.8	-2)	16,6	32,9	51,4	-2)	-2)	-2)
			8.8	-2)	22,2	43,9	68,6	-2)	-2)	-2)
	Stainless steel R and high corrosion resistant steel HCR	Property class	50	-2)	13,9	27,4	42,8	-2)	-2)	-2)
			70	-2)	19,4	38,4	60,0	-2)	-2)	-2)
			80	-2)	22,2	43,9	68,6	-2)	-2)	-2)

<sup>1)</sup> Partial factors for performance category C2 see **Table C16.1**; for Anchor rods the factor for steel ductility is 1,0.

<sup>2)</sup> No performance assessed.

fischer injection system FIS V Plus

**Performances**

Characteristic resistance to steel failure under tension / shear loading for Anchor rods and Threaded rods under seismic action (performance category C2)

**Annex C15**

Appendix 38 / 41

**Table C16.1: Partial factors for Anchor rods, Threaded rods under seismic action performance category C1 or C2**

Anchor rod / Threaded rod		M10	M12	M16	M20	M24	M27	M30
<b>Characteristic resistance to steel failure under tension loading <sup>1)</sup></b>								
Partial factor $\gamma_{Ms,N}$	Steel zinc plated	Property class	4.8	[-]	1,50			
			5.8		1,50			
			8.8		1,50			
	Stainless steel R and high corrosion resistant steel HCR		50		2,86			
			70		1,87 / fischer HCR: 1,50 <sup>2)</sup>			
			80		1,60			

<b>Characteristic resistance to steel failure under shear loading <sup>1)</sup></b>								
Partial factor $\gamma_{Ms,V}$	Steel zinc plated	Property class	4.8	[-]	1,25			
			5.8		1,25			
			8.8		1,25			
	Stainless steel R and high corrosion resistant steel HCR		50		2,38			
			70		1,56 / fischer HCR: 1,25 <sup>2)</sup>			
			80		1,33			

<sup>1)</sup> In absence of other national regulations.

<sup>2)</sup> Only admissible for high corrosion resistant steel HCR, acc. to **Table A7.1**.

fischer injection system FIS V Plus

**Performances**

Partial factors under seismic action (performance category C1 and C2) for Anchor rods and Threaded rods

**Annex C16**

Appendix 39 / 41

**Table C17.1:** Characteristic resistance to **combined pull-out and concrete failure** for **Anchor rods and Threaded rods** in hammer drilled holes under seismic action performance category **C1**, concrete  $\geq$  **C20/25**; **working life 50 and 100 years**

Anchor rod / Threaded rod		M10	M12	M16	M20	M24	M27	M30	
<b>Combined pullout and concrete cone failure</b>									
<b>Characteristic bond resistance</b>									
<b>Hammer-drilling with standard drill bit or hollow drill bit (dry or wet concrete)</b>									
Temperature range	I: 50 °C / 80 °C	$\tau_{Rk,C1}$ [N/mm <sup>2</sup> ]	4,5	5,5	5,5	5,5	4,5	4,0	4,0
	II: 72 °C / 120 °C		4,0	4,5	4,5	4,5	4,0	3,5	3,5
<b>Hammer-drilling with standard drill bit or hollow drill bit (water filled hole)</b>									
Temperature range	I: 50 °C / 80 °C	$\tau_{Rk,C1}$ [N/mm <sup>2</sup> ]	- <sup>1)</sup>	5,0	5,0	4,5	4,0	3,5	3,5
	II: 72 °C / 120 °C		- <sup>1)</sup>	4,0	4,0	4,0	3,5	3,0	3,0
<b>Installation factors</b>									
Dry or wet concrete	$\gamma_{inst}$	[-]	1,0						
Water filled hole			- <sup>1)</sup>	1,2					

<sup>1)</sup> No performance assessed.

fischer injection system FIS V Plus

**Performances**

Characteristic resistance under seismic action (performance category C1) for Anchor rods and Threaded rods, working life 50 and 100 years

**Annex C17**

Appendix 40 / 41

**Table C18.1:** Characteristic resistance to **combined pull-out and concrete failure** for **Anchor rods / Threaded rods** in hammer drilled holes under seismic action performance category **C2**; concrete  $\geq$  **C20/25**; working life **50 and 100 years**

Anchor rod / Threaded rod		M12	M16	M20	
<b>Combined pullout and concrete cone failure</b>					
<b>Characteristic bond resistance</b>					
<u>Hammer-drilling with standard drill bit or hollow drill bit (dry or wet concrete)</u>					
Temperature range	I: 50 °C / 80 °C	$\tau_{Rk,C2}$ [N/mm <sup>2</sup> ]	1,5	1,3	2,1
	II: 72 °C / 120 °C		1,3	1,2	1,9
<u>Hammer-drilling with standard drill bit or hollow drill bit (water filled hole)</u>					
Temperature range	I: 50 °C / 80 °C	$\tau_{Rk,C2}$ [N/mm <sup>2</sup> ]	1,3	1,1	1,8
	II: 72 °C / 120 °C		1,1	1,0	1,6
<b>Installation factors</b>					
Dry or wet concrete		$\gamma_{inst}$ [-]	1,0		
Water filled hole			1,2		
<b>Displacement-Factors for tension loading<sup>1)</sup></b>					
$\delta_{N,C2(50\%)-Factor}$		[mm/(N/mm <sup>2</sup> )]	0,20	0,13	0,21
$\delta_{N,C2(100\%)-Factor}$			0,38	0,18	0,24
<b>Displacement-Factors for shear loading<sup>2)</sup></b>					
$\delta_{V,C2(50\%)-Factor}$		[mm/kN]	0,18	0,10	0,07
$\delta_{V,C2(100\%)-Factor}$			0,25	0,14	0,11

1) Calculation of effective displacement:

$$\delta_{N,C2(50\%)} = \delta_{N,C2(50\%)-Factor} \cdot \tau$$

$$\delta_{N,C2(100\%)} = \delta_{N,C2(100\%)-Factor} \cdot \tau$$

$\tau$  = acting bond strength under tension loading

2) Calculation of effective displacement:

$$\delta_{V,C2(50\%)} = \delta_{V,C2(50\%)-Factor} \cdot V$$

$$\delta_{V,C2(100\%)} = \delta_{V,C2(100\%)-Factor} \cdot V$$

V: acting shear loading

fischer injection system FIS V Plus

**Performances**

Characteristic resistance under seismic action (performance category C2) for Anchor rods; working life 50 and 100 years

**Annex C18**

Appendix 41 / 41