

## ΔΗΛΩΣΗ ΕΠΙΔΟΣΕΩΝ

### DoP 0263

για fischer αγκύριο TA M, TA M S, TA M T (Εκτομούμενα αγκύρια για χρήση σε μπετόν)

EL

- |   |   |
|---|---|
| 1. <u>Μοναδικός κωδικός ταυτοποίησης του τύπου του προϊόντος:</u>   | DoP 0263  |
| 2. <u>Προβλεπόμενη(-ες) χρήση(-εις):</u>  | Μεταγενέστερη στερέωση σε μη ρηγματωμένο σκυρόδεμα, δείτε το παράρτημα, ειδικά τα παραρτήματα B1 - B3.        |
| 3. <u>Κατασκευαστής:</u>  | fischerwerke GmbH & Co. KG, Klaus-Fischer-Str. 1, 72178 Waldachtal, Γερμανία                                  |
| 4. <u>Εξουσιοδοτημένος αντιπρόσωπος:</u>  | -   |
| 5. <u>Σύστημα/συστήματα AVCP (αξιολόγηση και επαλήθευση της σταθερότητας της επίδοσης):</u>   | 1   |
| 6. <u>Ευρωπαϊκό έγγραφο αξιολόγησης:</u><br>Ευρωπαϊκή τεχνική αξιολόγηση:<br>Οργανισμός τεχνικής αξιολόγησης:<br>Κοινοποιημένος(-οι) οργανισμός(-οι): | EAD 330232-00-0601<br>ETA-04/0003; 2018-06-12<br>DIBt- Deutsches Institut für Bautechnik<br>2873 TU Darmstadt |

### 7. Δηλωθείσα(-ες) επίδοση(-εις):

#### Μηχανική αντίσταση και σταθερότητα (BWR1)

##### Χαρακτηριστική αντίσταση σε εφελκυστικό φορτίο (στατικό και σχεδόν στατικό):

Αντίσταση σε αστοχία χάλυβα: Παράρτημα C1

$E_s = 210\,000\text{ MPa}$

Αντίσταση σε αστοχία από εξόλκευση: Παράρτημα C1

Αντίσταση σε αστοχία από κών σκυροδέματος: Παράρτημα C1

Ανθεκτικότητα: Παράρτημα C1

Ελάχιστη απόσταση από ακμή και μεταξύ αγκυρίων: Παράρτημα B2

Απόσταση από ακμή για αποφυγή θραύσης από φορτίο: Παράρτημα C1

$N_{Rk,sp}^{0} = \text{NPD}$

##### Χαρακτηριστική αντίσταση σε διατμητικό φορτίο (στατικό και σχεδόν στατικό):

Αντίσταση σε αστοχία χάλυβα (διατμητικό φορτίο): Παράρτημα C2

Αντίσταση σε ολίσθηση: Παράρτημα C2

Αντίσταση σε αστοχία ακμής σκυροδέματος: Παράρτημα C2

Μεταπίσεις υπό στατικό και σχεδόν στατικό φορτίο: Παράρτημα C2

Διάρκεια: Παραρτήματα A3, A4, B1

##### Χαρακτηριστική αντίσταση και μετακινήσεις για τις σεισμικές κατηγορίες C1 και C2 (προαιρετικά):

Αντίσταση σε αστοχία χάλυβα: NPD

Αντίσταση σε αστοχία από εξόλκευση: NPD

Επιμήκυνση διαρροής: NPD

Παράμετρος περιμετρικού κενού: NPD

Μετακινήσεις: NPD

#### Ασφάλεια σε περίπτωση φωτιάς (BWR 2)

Αντίδραση σε φωτιά: Κατηγορίας A 1

##### Αντίσταση στη φωτιά:

Αντίσταση σε φωτιά για αστοχία χάλυβα (εφελκυστικό φορτίο): NPD

Αντίσταση σε φωτιά για εξόλκευση (εφελκυστικό φορτίο): NPD

Αντίσταση σε φωτιά για αστοχία χάλυβα (διατμητικό φορτίο): NPD

### 8. Κατάλληλη τεχνική τεκμηρίωση και/ή ειδική τεχνική τεκμηρίωση:

-

Η επίδοση του προϊόντος που ταυτοποιείται ανωτέρω είναι σύμφωνη με τη (τις) δηλωθείσα(-ες) επίδοση(-εις). Αυτή η δήλωση επιδόσεων εκδίδεται σύμφωνα με τον Κανονισμό (ΕΕ) Αρ. 305/2011 με αποκλειστική ευθύνη του κατασκευαστή που προσδιορίζεται παραπάνω.

Υπογραφή για λογαριασμό και εξ ονόματος του κατασκευαστή από:

Dr.-Ing. Oliver Geibig, Γενικός Διευθυντής Επιχειρηματικών Μονάδων & Μηχανικής  
Tumlingen, 2021-01-12

Jürgen Grün, Γενικός Διευθυντής Χημικών & Ποιότητας

Αυτή η Δήλωση Επιδόσεων μεταφράστηκε σε διάφορες γλώσσες. Σε περίπτωση που υπάρχει αμφιβολία για τη μετάφραση, υπερισχύει πάντα η αγγλική έκδοση.

Το παράρτημα περιλαμβάνει προαιρετικές και συμπληρωματικές πληροφορίες στα αγγλικά, που ξεπερνούν τις (οριζόμενες σε άλλες γλώσσες) νόμιμες απαιτήσεις.

## Specific Part

### 1 Technical description of the product

The fischer Heavy-duty anchor TA M, TA M S and TA M T in the range of M6, M8, M10 and M12 is an anchor made of galvanised steel which is placed into a drilled hole and anchored by torque-controlled expansion with the hexagon head bolt.

The product description is given in Annex A.

### 2 Specification of the intended use in accordance with the applicable European Assessment Document

The performances given in Section 3 are only valid if the concrete screw is used in compliance with the specifications and conditions given in Annex B.

The verifications and assessment methods on which this European Technical Assessment is based lead the assumption of working life of the concrete screw of at least 50 years. The indications given on the working life cannot be interpreted as a guarantee given by the producer, but are to be regarded only as a means for choosing the right products in relation to the expected economically reasonable working life of the works.

### 3 Performance of the product and references to the methods used for its assessment

#### 3.1 Mechanical resistance and stability (BWR 1)

Essential characteristic	Performance
Characteristic resistance to tension load (static and quasi-static loading)	see Annex C 1
Characteristic resistance to shear load (static and quasi-static loading)	see Annex C 2
Displacements (static and quasi-static loading)	see Annex C 2
Characteristic resistance and displacements for seismic performance categories C1 and C2	No performance assessed

#### 3.2 Safety in case of fire (BWR 2)

Essential characteristic	Performance
Reaction to fire	Class A1
Resistance to fire	No performance assessed

### 4 Assessment and verification of constancy of performance (AVCP) system applied, with reference to its legal base

In accordance with European Assessment Documents EAD No. 330232-00-0601 the applicable European legal act is: [96/582/EC].

The system to be applied is: 1

## Pre-positioned installation:

### TA M

The hexagon head screw and the washer according to table A4.1 and A4.2 must be provided by the user

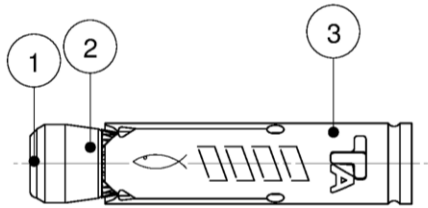

### TA M S

The hexagon head screw is provided by the manufacturer (fischer) together with the anchor

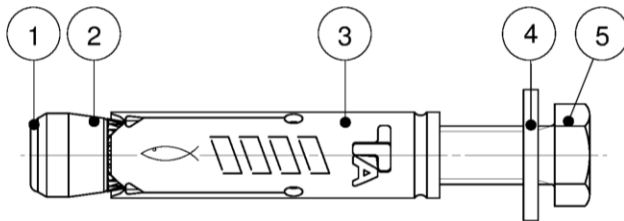

## In-place installation:

### TA M T

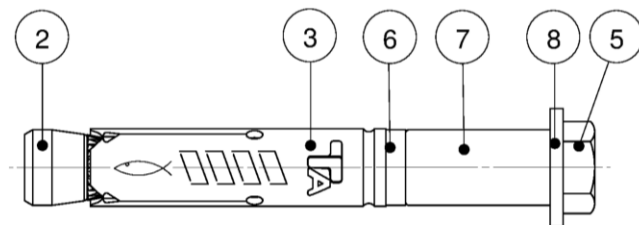

- |                          |                      |
|--------------------------|----------------------|
| 1 Plastic cap (optional) | 5 Hexagon head screw |
| 2 Cone-nut               | 6 Distance ring      |
| 3 Expansion sleeve       | 7 Spacing sleeve     |
| 4 Washer (TA M / TA M S) | 8 Washer (TA M T)    |

(Fig. not to scale)

**fischer Heavy-duty anchor TA M, TA M S, TA M T**

**Product description**  
Anchor types

**Annex A 1**

Appendix 2 / 10

# TA M / TA M S

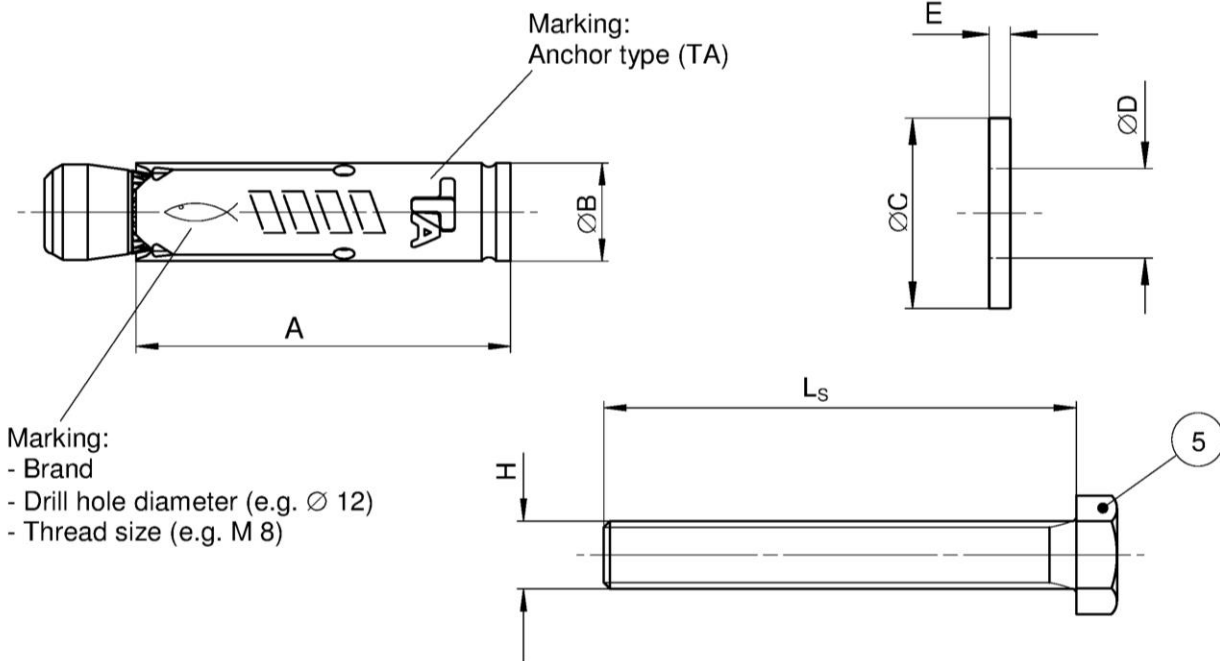

# TA M T

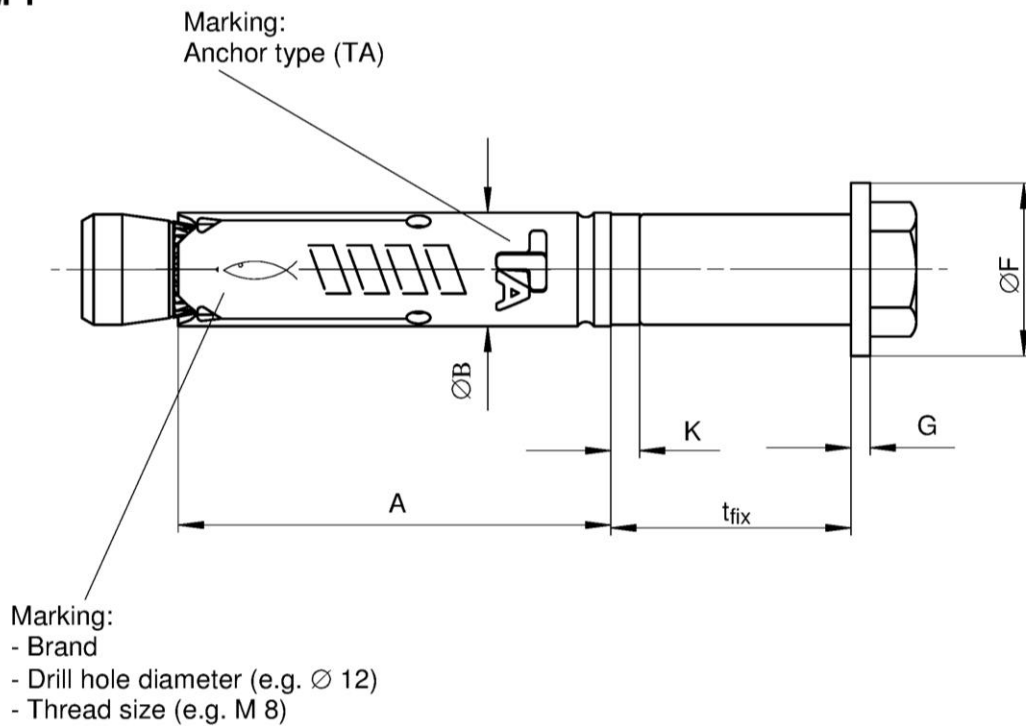

(Fig. not to scale)

**fischer Heavy-duty anchor TA M, TA M S, TA M T**

**Product description**  
Anchor components

**Annex A 2**

Appendix 3 / 10

**Table A3.1: Anchor dimensions [mm]**

Part	Designation	Type of anchor		M6	M8	M10	M12
3	Expansion sleeve	TA M / TA M S / TA M T	A	40,0	45,0	55,0	70,0
			∅ B	9,6	11,8	14,5	17,5
4	Washer <sup>1)</sup>	TA M S	∅ C ≥	11,0	15,0	19,0	23,0
			E ≥	1,4	1,4	1,8	2,3
8	Washer	TA M T	∅ F ≥	17,0	21,0	25,0	30,0
			G ≥	1,4	1,8	2,3	2,7
5	Hexagon head screw <sup>2)</sup>	TA M S / TA M T	L <sub>s</sub> ≥	t <sub>fix</sub> + 50	t <sub>fix</sub> + 55	t <sub>fix</sub> + 70	t <sub>fix</sub> + 85
			H	M6	M8	M10	M12
6	Distance ring	TA M T	K =	3,0	3,0	3,0	3,0

<sup>1)</sup> For specification - summary of washer for TA M see table A4.2

<sup>2)</sup> For specification - summary of hexagon head screw for TA M see table A4.1

**Table A3.2: Materials**

Part	Designation	Type of anchor	Materials	Treatment
1	Plastic cap <sup>1)</sup>	TA M / TA M S	Polyamide	-
2	Cone-nut	TA M / TA M S / TA M T	Steel, EN 10277:2008	Zinc plated according to EN ISO 4042:2017, min 5 µm, additional functional coating
3	Expansion sleeve	TA M / TA M S / TA M T	Cold-rolled steel EN 10139:2016	Zinc plated according to EN ISO 4042:2017, min 5 µm
4	Washer <sup>2)</sup>	TA M S	Steel, min 140 HV	
8	Washer	TA M T		
5	Hexagon head screw <sup>3)</sup>	TA M S / TA M T	Steel, property class 8.8	
6	Distance ring	TA M T	Polyethylen	-
7	Distance sleeve	TA M T	Cold-rolled steel EN 10139:2016/ Steel EN 10 277:2008	Zinc plated according to EN ISO 4042:2017, min 5 µm

<sup>1)</sup> Optional

<sup>2)</sup> For specification - summary of washer for TA M see table A4.2

<sup>3)</sup> For specification - summary of hexagon head screw for TA M see table A4.1

**fischer Heavy-duty anchor TA M, TA M S, TA M T**

**Product description**  
Anchor dimensions  
Materials

**Annex A 3**

Appendix 4 / 10

**Table A4.1:** Selection criteria for the hexagon head screw (TA M)

Description			TA M6	TA M8	TA M10	TA M12
Length of hexagon head screw	$L_S$	[mm]	$\geq t_{fix} + 50$	$\geq t_{fix} + 55$	$\geq t_{fix} + 70$	$\geq t_{fix} + 85$
Thread size	H	[-]	M6	M8	M10	M12
Standardisation			ISO 4014:2017 / ISO 4017:2014 or DIN 931:1987 / DIN 933:1987			
Material			Steel, property class 8.8			
Treatment			Zinc plated according to EN ISO 4042:2017, min 5 $\mu$ m			

**Table A4.2:** Selection criteria for the washer (TA M)

Description			TA M6	TA M8	TA M10	TA M12
Hole diameter	D	min	6,0	8,0	10,0	12,0
		max	6,6	8,6	10,8	13,3
External diameter	C	[mm]	$\geq 11,0$	$\geq 15,0$	$\geq 19,0$	$\geq 23,0$
Thickness	E	min	1,4	1,4	1,8	2,3
		max	3,0	3,0	4,0	5,0
Material			Steel, hardness class min 140 HV			
Treatment			Zinc plated according to EN ISO 4042:2017, min 5 $\mu$ m			

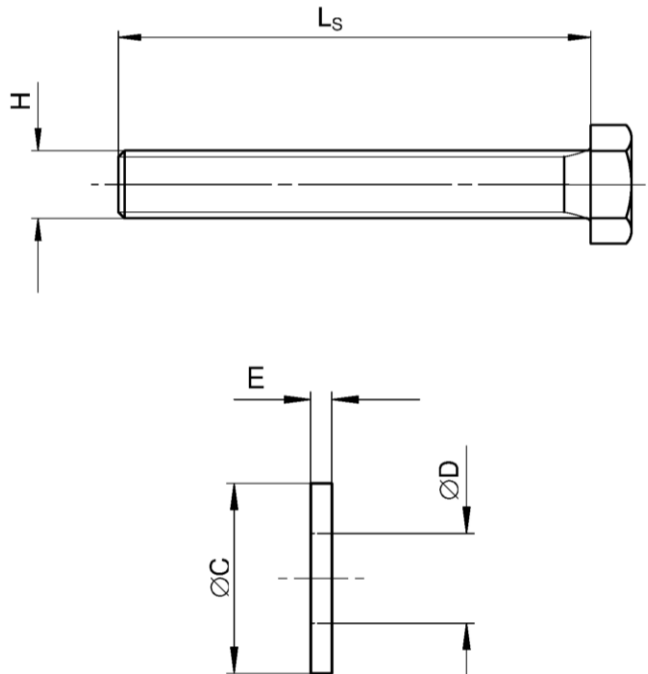

(Fig. not to scale)

**fischer Heavy-duty anchor TA M, TA M S, TA M T**

**Product description**  
Dimensions  
Materials

**Annex A 4**

Appendix 5 / 10

## Specifications of intended use

fischer Heavy-duty anchor	TA M6	TA M8	TA M10	TA M12
Steel, zinc plated			✓	
Static and quasi-static loads			✓	
Uncracked concrete			✓	

**Base materials:**

- Normal weight concrete according to EN 206-1:2000
- Strength classes C20/25 to C50/60 according to EN 206-1:2000

**Use conditions (Environmental conditions):**

- Structures subject to dry internal conditions

**Design:**

- Anchorages have to be designed under the responsibility of an engineer experienced in anchorages and concrete work
- Verifiable calculation notes and drawings have to be prepared taking account of the loads to be anchored. The position of the anchor is indicated on the design drawings (e.g. position of the anchor relative to reinforcement or to supports, etc.)
- Design of fastenings according to FprEN 1992-4: 2016 and EOTA Technical Report TR 055

**Installation:**

- Anchor installation carried out by appropriately qualified personnel and under the supervision of the person responsible for technical matters of the site
- Hammer or hollow drilling according to Annex B3
- Drill hole created perpendicular +/- 5° to concrete surface, positioning without damaging the reinforcement
- In case of aborted hole: new drilling at a minimum distance twice the depth of the aborted drill hole or smaller distance if the aborted drill hole is filled with high strength mortar and if under shear or oblique tension load it is not in the direction of load application

**fischer Heavy-duty anchor TA M, TA M S, TA M T**

**Intended use**  
Specifications

**Annex B 1**

Appendix 6 / 10

**Table B2.1:** Installation parameters for TA M / TA M S / TA M T

Anchor size		TA M6	TA M8	TA M10	TA M12
Nominal drill hole diameter	$d_0$	10	12	15	18
Maximum drill bit diameter	$d_{cut} \leq$	10,45	12,50	15,50	18,50
Length of hexagon head screw	$L_s \geq$	$t_{fix} + 50$	$t_{fix} + 55$	$t_{fix} + 70$	$t_{fix} + 85$
Depth of drill hole (TA M / TA M S)	$h_1 \geq$	$L_s - t_{fix} + 15$		$L_s - t_{fix} + 20$	
Depth of drill hole (TA M T)	$h_1 \geq$	$L_s + 10$			
Diameter of clearance hole in the fixture (TA M / TA M S)	$d_f$ [mm]	7	9	12	14
Diameter of clearance hole in the fixture (TA M T)	$d_f \leq$	12	14	18	20
Thickness of fixture	$t_{fix,min}$	1			
	$t_{fix,max}$	150	200	250	300
Required torque moment	$T_{inst}$ [Nm]	10	20	40	75

**TA M / TA M S:**

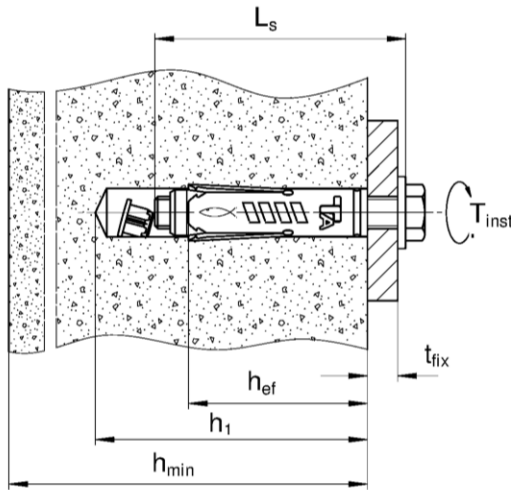

**TA M T:**

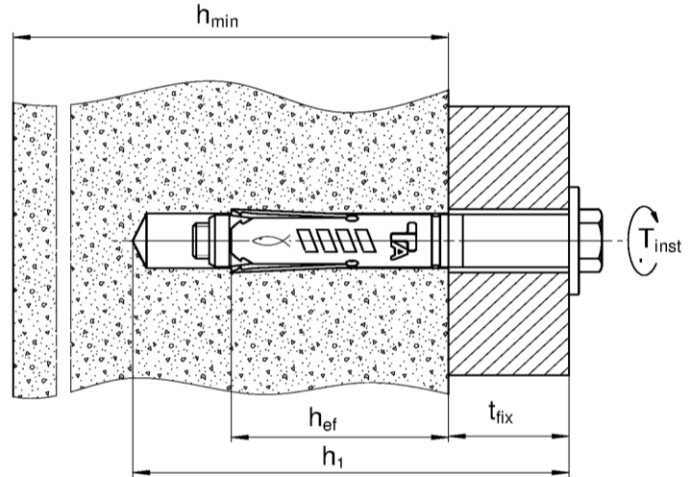

- $L_s$  = Length of hexagon head screw
- $h_{ef}$  = Effective embedment depth
- $t_{fix}$  = Thickness of the fixture

- $h_{min}$  = Minimum thickness of concrete member
- $h_1$  = Depth of drill hole to deepest point
- $T_{inst}$  = Required setting torque

**Table B2.2:** Minimum thickness of concrete member, minimum spacing and minimum edge distances

Anchor size		TA M6	TA M8	TA M10	TA M12
Minimum thickness of concrete member	$h_{min}$	100	100	110	140
Minimum spacing	$s_{min}$ [mm]	80	90	110	160
Minimum edge distance	$c_{min}$	50	60	70	120

(Fig. not to scale)

**fischer Heavy-duty anchor TA M, TA M S, TA M T**

**Intended Use**

Installation instructions  
 Minimum thickness of concrete member, minimum spacing and minimum edge distance

**Annex B 2**



## Installation instruction

### Pre-positioned installation TA M / TA M S

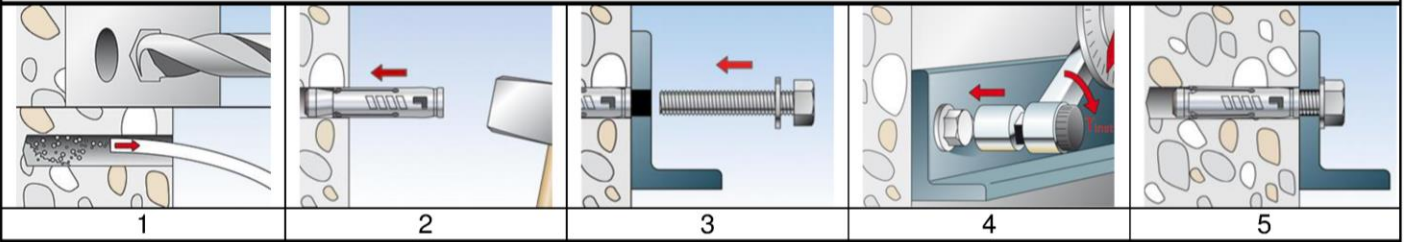

No.	Description	
1	Create drill hole with hammer drill, clean bore hole	Create drill hole with hollow drill and vacuum cleaner
2	Set the fastener	
3	Attach the fixture and turn the screw in	
4	Apply required torque moment $T_{inst}$	
5	Installed fastener	

### Push-through installation TA M T

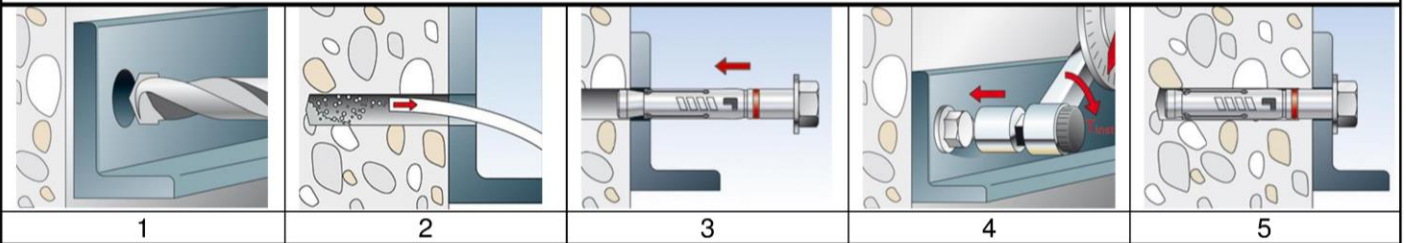

No.	Description	
1	Create drill hole with hammer drill	Create drill hole with hollow drill and vacuum cleaner
2	Clean bore hole	-
3	Set the fastener	
4	Apply required torque moment $T_{inst}$	
5	Installed fastener	

#### Types of drills

Hammer drill



Hollow drill



**fischer Heavy-duty anchor TA M, TA M S, TA M T**

**Intended use**  
Installation instruction

**Annex B 3**

Appendix 8 / 10

**Table C 1.1:** Characteristic **tension** resistance under static and quasi-static loads

Anchor size		TA M6	TA M8	TA M10	TA M12		
<b>Steel failure</b>							
Characteristic resistance property class 8.8	$N_{Rk,s}$	[kN]	16,1	29,3	46,4	67,4	
Partial factor	$\gamma_{Ms}$ <sup>1)</sup>	[-]	1,5				
<b>Pull-out failure</b>							
Characteristic resistance in uncracked concrete	$N_{Rk,p}$	[kN]	C20/25	7,5	12	20	25
Increasing factors for $N_{Rk,p}$ for uncracked concrete	$\psi_c$		C25/30	1,12			
			C30/37	1,22			
			C35/45	1,32			
			C40/50	1,41			
			C45/55	1,50			
			C50/60	1,58			
Installation factor	$\gamma_{inst}$	[-]	1,0				
<b>Concrete cone failure and splitting failure</b>							
Effective embedment depth	$h_{ef}$	[mm]	40	45	55	70	
Factor $k_1$	$k_{ucr,N}$	[-]	11,0 <sup>2)</sup>				
Spacing (concrete cone failure)	$s_{cr,N}$	[mm]	120	135	220	210	
Edge distance (concrete cone failure)	$c_{cr,N}$		60	68	110	105	
Spacing (splitting)	$s_{cr,sp}$		120	180	330	420	
Edge distance (splitting)	$c_{cr,sp}$		60	90	165	210	

<sup>1)</sup> In absence of other national regulations

<sup>2)</sup> Based on concrete strength as cylinder strength

**fischer Heavy-duty anchor TA M, TA M S, TA M T**

**Performances**

Characteristic **tension** resistance under static and quasi-static loads

**Annex C 1**

Appendix 9 / 10

**Table C2.1:** Characteristic values of **shear** resistance under static and quasi-static loads

Anchor size		TA M6	TA M8	TA M10	TA M12
<b>Shear load without lever arm</b>					
Characteristic resistance property class 8.8	$V_{Rk,s}^0$ [kN]	5,8	11,7	19,2	29,8
Partial factor	$\gamma_{Ms}^{1)}$ [-]	1,25			
Ductility factor	$k_7$ [-]	1,0			
<b>Shear load with lever arm</b>					
Characteristic bending moment property class 8.8	$M_{Rk,s}^0$ [Nm]	12	30	60	105
Partial factor	$\gamma_{Ms}^{1)}$ [-]	1,25			
<b>Concrete pryout failure</b>					
Ductility factor	$k_7$ [-]	1,0			
Factor	$k_8$ [-]	1,1	1,8	1,8	2,0
<b>Concrete edge failure</b>					
Effective length of the fastener	$l_f$ [mm]	40	45	55	70
Outside diameter of fastener	$d_{nom}$ [mm]	10	12	15	18

<sup>1)</sup> In absence of other national regulations

**Table C2.2:** Displacements under static and quasi static **tension** loads

Anchor size		TA M6	TA M8	TA M10	TA M12
Tension load in uncracked concrete	[kN]	3,0	4,8	7,9	9,9
Displacements	$\frac{\delta_{N0}}{\delta_{N\infty}}$ [mm]	0,7	0,7	1,2	1,2
		1,0	1,0	1,8	1,8

**Table C2.3:** Displacements under static and quasi static **shear** loads

Anchor size		TA M6	TA M8	TA M10	TA M12
Shear load in uncracked concrete	[kN]	3,3	6,7	11,0	17,0
Displacements	$\frac{\delta_{V0}}{\delta_{V\infty}}$ [mm]	2,1	1,9	3,1	3,3
		3,1	2,8	4,6	4,9

**fischer Heavy-duty anchor TA M, TA M S, TA M T**

**Performances**

Characteristic **shear** resistance under static and quasi-static loads  
Displacements under tension and shear loads

**Annex C 2**

Appendix 10 / 10