

## ΔΗΛΩΣΗ ΕΠΙΔΟΣΕΩΝ

### DoP 0321

για fischer Strong Undercut Anchor FSU (Εκτομούμενα αγκύρια για χρήση σε μπετόν)

EL

- |   |  |
|---|--|
| 1. <u>Μοναδικός κωδικός ταυτοποίησης του τύπου του προϊόντος:</u>   | <b>DoP 0321</b>  |
| 2. <u>Προβλεπόμενη(-ες) χρήση(-εις):</u>  | <b>Μεταγενέστερη αγκύρωση σε ρηγματωμένο ή μη ρηγματωμένο σκυρόδεμα, δείτε το παράρτημα, ειδικά τα παραρτήματα B1 - B5.</b>                  |
| 3. <u>Κατασκευαστής:</u>  | <b>fischerwerke GmbH &amp; Co. KG, Klaus-Fischer-Str. 1, 72178 Waldachtal, Γερμανία</b>  |
| 4. <u>Εξουσιοδοτημένος αντιπρόσωπος:</u>  | –  |
| 5. <u>Σύστημα/συστήματα AVCP (αξιολόγηση και επαλήθευση της σταθερότητας της επίδοσης):</u>   | 1  |
| 6. <u>Ευρωπαϊκό έγγραφο αξιολόγησης:</u><br>Ευρωπαϊκή τεχνική αξιολόγηση:<br>Οργανισμός τεχνικής αξιολόγησης:<br>Κοινοποιημένος(-οι) οργανισμός(-οι): | <b>EAD 330232-01-0601-v02, Edition 06/2023<br/>ETA-22/0674; 2023-07-26<br/>DIBT- Deutsches Institut für Bautechnik<br/>2873 TU Darmstadt</b> |

### 7. Δηλωθείσα(-ες) επίδοση(-εις):

#### **Μηχανική αντίσταση και σταθερότητα (BWR1)**

##### **Χαρακτηριστική αντίσταση σε εφελκυστικό φορτίο (στατικό και σχεδόν στατικό) μέθοδος A:**

Αντίσταση σε αστοχία χάλυβα: δείτε το παράρτημα, ειδικά τα Παράρτημα C1

Αντίσταση σε αστοχία από εξόλκευση: δείτε το παράρτημα, ειδικά τα Παράρτημα C1

Αντίσταση σε αστοχία από κώνο σκυροδέματος: δείτε το παράρτημα, ειδικά τα Παράρτημα C1

Ανθεκτικότητα: δείτε το παράρτημα, ειδικά τα Παράρτημα C1

Ελάχιστη απόσταση από ακμή και μεταξύ αγκυρίων: δείτε το παράρτημα, ειδικά τα Παράρτημα C3

Απόσταση από ακμή για αποφυγή θραύσης από φορτίο: δείτε το παράρτημα, ειδικά τα Παράρτημα C1

$E_s = 210\,000\text{ MPa}$

##### **Χαρακτηριστική αντίσταση σε διαμητικό φορτίο (στατικό και σχεδόν στατικό) μέθοδος A:**

Αντίσταση σε αστοχία χάλυβα (διαμητικό φορτίο): δείτε το παράρτημα, ειδικά τα Παράρτημα C2

Αντίσταση σε ολίσθηση: δείτε το παράρτημα, ειδικά τα Παράρτημα C2

##### **Χαρακτηριστική αντίσταση για απλοποιημένο σχεδιασμό:**

Μέθοδος B: NPD

Μέθοδος C: NPD

##### **Μετατόπιση:**

Μετατοπίσεις υπό στατικό και σχεδόν στατικό φορτίο: δείτε το παράρτημα, ειδικά τα Παράρτημα C6

##### **Χαρακτηριστική αντίσταση και μετακινήσεις για τις σεισμικές κατηγορίες C1 και C2 (προαιρετικά):**

Αντίσταση σε εφελκυσμό, μετατόπιση, κατηγορία C1: δείτε το παράρτημα, ειδικά τα Παράρτημα C5

Αντίσταση σε εφελκυσμό, μετατόπιση, κατηγορία C2: δείτε το παράρτημα, ειδικά τα Παραρτήματα C5, C6

Αντίσταση σε διάτμηση, μετατόπιση, κατηγορία C1: δείτε το παράρτημα, ειδικά τα Παράρτημα C5

Αντίσταση σε διάτμηση, μετατόπιση, κατηγορία C2: δείτε το παράρτημα, ειδικά τα Παραρτήματα C5, C6

Παράμετρος περιμετρικού κενού: δείτε το παράρτημα, ειδικά τα Παράρτημα C5

#### **Ασφάλεια σε περίπτωση φωτιάς (BWR 2)**

Αντίδραση σε φωτιά: Κατηγορία (A1)

##### **Αντίσταση στη φωτιά:**

Αντίσταση σε φωτιά για αστοχία χάλυβα (εφελκυστικό φορτίο): δείτε το παράρτημα, ειδικά τα Παράρτημα C4

Αντίσταση σε φωτιά για εξόλκευση (εφελκυστικό φορτίο): δείτε το παράρτημα, ειδικά τα Παράρτημα C4

Αντίσταση σε φωτιά για αστοχία χάλυβα (διαμητικό φορτίο): δείτε το παράρτημα, ειδικά τα Παράρτημα C4

##### **Διάρκεια:**

Διάρκεια: δείτε το παράρτημα, ειδικά τα Παραρτήματα A2, B1

8. Κατάλληλη τεχνική τεκμηρίωση και/ή ειδική τεχνική τεκμηρίωση: -

Η επίδοση του προϊόντος που ταυτοποιείται ανωτέρω είναι σύμφωνη με τη (τις) δηλωθείσα(-ες) επίδοση(-εις). Αυτή η δήλωση επιδόσεων εκδίδεται σύμφωνα με τον Κανονισμό (ΕΕ) Αρ. 305/2011 με αποκλειστική ευθύνη του κατασκευαστή που προσδιορίζεται παραπάνω.

Υπογραφή για λογαριασμό και εξ ονόματος του κατασκευαστή από:



Dr.-Ing. Oliver Geibig, Γενικός Διευθυντής Επιχειρηματικών Μονάδων & Μηχανικής  
Tumlingen, 2023-09-01



Jürgen Grün, Γενικός Διευθυντής Χημικών & Ποιότητας

Αυτή η Δήλωση Επιδόσεων μεταφράστηκε σε διάφορες γλώσσες. Σε περίπτωση που υπάρχει αμφιβολία για τη μετάφραση, υπερισχύει πάντα η αγγλική έκδοση.

Το παράρτημα περιλαμβάνει προαιρετικές και συμπληρωματικές πληροφορίες στα αγγλικά, που ξεπερνούν τις (οριζόμενες σε άλλες γλώσσες) νόμιμες απαιτήσεις.

Translation guidance Essential Characteristics and Performance Parameters for Annexes

**Οδηγίες Μετάφρασης των βασικών χαρακτηριστικών και απόδοσης για τα παραρτήματα**

Mechanical resistance and stability (BWR 1)		
<b>Μηχανική αντίσταση και σταθερότητα (BWR1)</b>		
Characteristic resistance under static and quasi-static loading, Method A		
<b>Χαρακτηριστική αντίσταση σε εφελκυστικό φορτίο (στατικό και σχεδόν στατικό) μέθοδος Α:</b>		
1	Resistance to steel failure: <b>Αντίσταση σε αστοχία χάλυβα:</b>	$N_{Rk,s}$ [kN], $E_s$ [N/mm <sup>2</sup> ]
2	Resistance to pull-out failure: <b>Αντίσταση σε αστοχία από εξόλκευση:</b>	$N_{Rk,p}$ [kN], $\psi_c$
3	Resistance to concrete cone failure: <b>Αντίσταση σε αστοχία από κώνο σκυροδέματος:</b>	$k_{cr,N}$ , $k_{ucr,N}$ [-], $h_{ef}$ , $c_{cr,N}$ [mm]
4	Robustness: <b>Ανθεκτικότητα:</b>	$\gamma_{inst}$ [-]
5	Minimum edge distance and spacing: <b>Ελάχιστη απόσταση από ακμή και μεταξύ αγκυρίων:</b>	$c_{min}$ , $s_{min}$ , $h_{min}$ [mm]
6	Edge distance to prevent splitting under load: <b>Απόσταση από ακμή για αποφυγή θραύσης από φορτίο:</b>	$N^0_{Rk,sp}$ [kN], $c_{cr,sp}$ [mm]
Characteristic resistance to shear load (static and quasi-static loading), Method A		
<b>Χαρακτηριστική αντίσταση σε διατμητικό φορτίο (στατικό και σχεδόν στατικό) μέθοδος Α:</b>		
7	Resistance to steel failure under shear load: <b>Αντίσταση σε αστοχία χάλυβα (διατμητικό φορτίο):</b>	$V^0_{Rk,s}$ [kN], $M^0_{Rk,s}$ [Nm], $k_7$ [-]
8	Resistance to pry-out failure: <b>Αντίσταση σε ολίσθηση:</b>	$k_8$ [-]
Characteristic Resistance for simplified design		
<b>Χαρακτηριστική αντίσταση για απλοποιημένο σχεδιασμό:</b>		
9	Method B: <b>Μέθοδος Β:</b>	$F^0_{Rk}$ [kN], $c_{cr}$ , $s_{cr}$ [mm]
10	Method C: <b>Μέθοδος C:</b>	$F_{Rk}$ [kN]
Displacements		
<b>Μετατόπιση:</b>		
11	Displacements under static and quasi-static loading: <b>Μετατοπίσεις υπό στατικό και σχεδόν στατικό φορτίο:</b>	$\delta_{N0}$ , $\delta_{N\infty}$ , $\delta_{V0}$ , $\delta_{V\infty}$ [mm]
Characteristic resistance and displacements for seismic performance categories C1 and C2		
<b>Χαρακτηριστική αντίσταση και μετακινήσεις για τις σεισμικές κατηγορίες C1 και C2 (προαιρετικά):</b>		
12	Resistance to tension load, displacements, category C1: <b>Αντίσταση σε εφελκυσμό, μετατόπιση, κατηγορία C1:</b>	$N_{Rk,s,C1}$ [kN], $N_{Rk,p,C1}$ [kN]
	Resistance to tension load, displacements, category C2: <b>Αντίσταση σε εφελκυσμό, μετατόπιση, κατηγορία C2:</b>	$N_{Rk,s,C2}$ [kN], $N_{Rk,p,C2}$ [kN], $\delta_{N,C2}$ [mm]
13	Resistance to shear load, displacements, category C1: <b>Αντίσταση σε διάτμηση, μετατόπιση, κατηγορία C1:</b>	$V_{Rk,s,C1}$ [kN]
	Resistance to shear load, displacements, category C2: <b>Αντίσταση σε διάτμηση, μετατόπιση, κατηγορία C2:</b>	$V_{Rk,s,C2}$ [kN], $\delta_{V,C2}$ [mm]
14	Factor for annular gap <b>Παράμετρος περιμετρικού κενού:</b>	$\alpha_{gap}$ [-]
Safety in case of fire (BWR 2)		
<b>Ασφάλεια σε περίπτωση φωτιάς (BWR 2)</b>		
15	Reaction to fire: <b>Αντίδραση σε φωτιά:</b>	Class
Resistance to fire:		
<b>Αντίσταση στη φωτιά:</b>		
16	Fire resistance to steel failure (tension load): <b>Αντίσταση σε φωτιά για αστοχία χάλυβα (εφελκυστικό φορτίο):</b>	$N_{Rk,s,fi}$ [kN]
17	Fire resistance to pull-out failure (tension load): <b>Αντίσταση σε φωτιά για εξόλκευση (εφελκυστικό φορτίο):</b>	$N_{Rk,p,fi}$ [kN]
18	Fire resistance to steel failure (shear load): <b>Αντίσταση σε φωτιά για αστοχία χάλυβα (διατμητικό φορτίο):</b>	$V_{Rk,s,fi}$ [kN], $M^0_{Rk,s,fi}$ [Nm]
Aspects of durability		
<b>Διάρκεια:</b>		
19	Durability: <b>Διάρκεια:</b>	Class

## Specific Part

### 1 Technical description of the product

The fischer Strong Undercut Anchor is an anchor made of galvanized steel which is placed in a cylindrical hole and anchored by displacement-controlled, self-undercutted mechanical interlock. The product description is given in Annex A.

### 2 Specification of the intended use in accordance with the applicable European Assessment Document

The performances given in Section 3 are only valid if the anchor is used in compliance with the specifications and conditions given in Annex B.

The verifications and assessment methods on which this European Technical Assessment is based lead to the assumption of a working life of the anchor of at least 50 years. The indications given on the working life cannot be interpreted as a guarantee given by the producer, but are to be regarded only as a means for choosing the right products in relation to the expected economically reasonable working life of the works.

### 3 Performance of the product and references to the methods used for its assessment

#### 3.1 Mechanical resistance and stability (BWR 1)

Essential characteristic	Performance
Characteristic resistance to tension load (static and quasi-static loading), Method A	See Annex C 1 and C 3
Characteristic resistance to shear load (static and quasi-static loading)	See Annex C 2
Displacements	See Annex C 6
Characteristic resistance and displacements for seismic performance categories C1 and C2	See Annex C 5 and C 6

#### 3.2 Safety in case of fire (BWR 2)

Essential characteristic	Performance
Reaction to fire	Class A1
Resistance to fire	See Annex C 4

#### 3.3 Aspects of Durability

Essential characteristic	Performance
Durability	See Annex B 1

**4 Assessment and verification of constancy of performance (AVCP) system applied, with reference to its legal base**

In accordance with the European Assessment Document EAD 330232-01-0601-v02 the applicable European legal act is: [96/582/EC].

The system to be applied is: 1

### Pre-setting anchor FSU

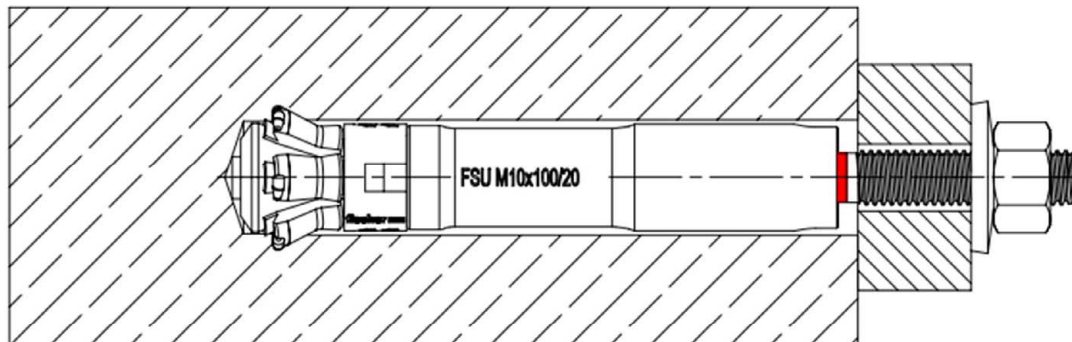

### Push-through anchor FSU-P

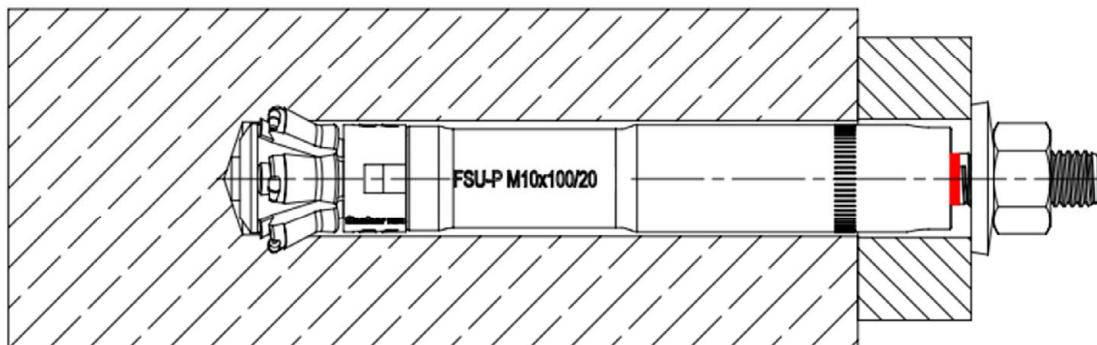

*(Fig. not to scale)*

fischer Strong Undercut Anchor FSU

**Product description**  
Installed condition

**Annex A 1**

Appendix 3 / 16

### Pre-setting anchor FSU

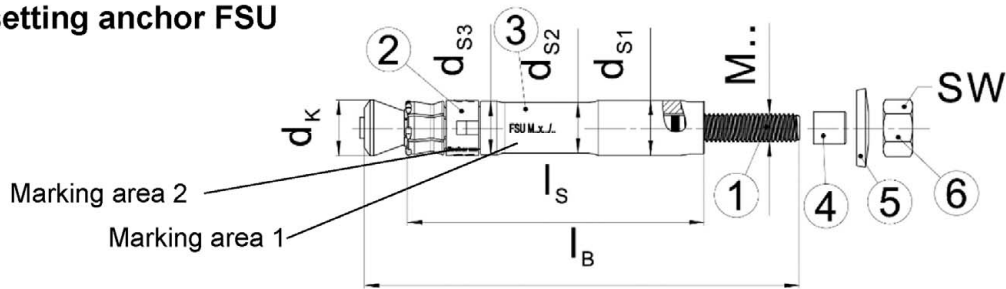

### Push-through anchor FSU-P

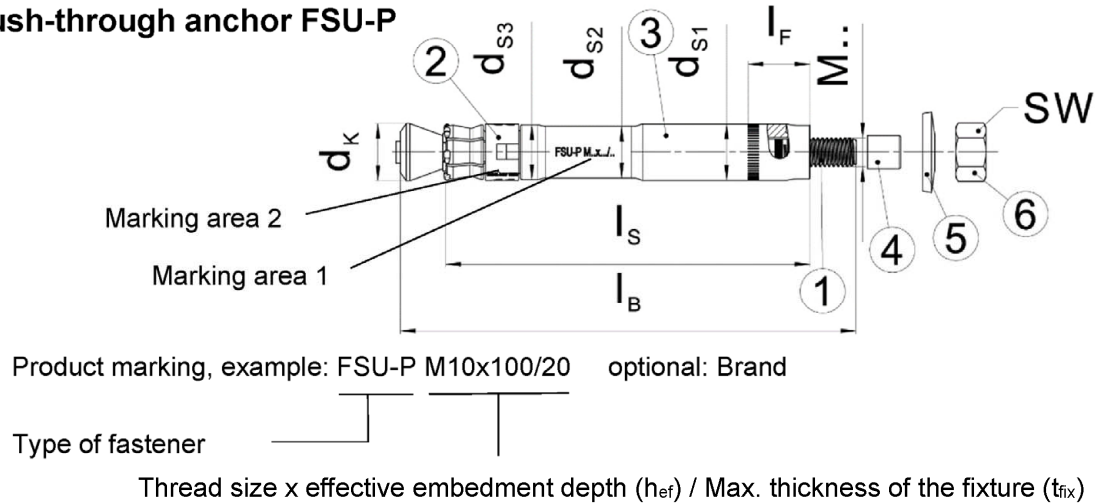

**Table A2.1: Dimensions [mm]**

Type of anchor	$t_{fix}$	$d_k$	$d_{s1}$	$d_{s2}$	$d_{s3}$	M	$l_s$	$l_B$	$l_F$	SW
FSU M10x100/20	$\leq 20$	19,3	19	17,5	18,5	10	100	148	-	17
FSU M12x125/30	$\leq 30$	21,5	21	19,3	20,5	12	125	188	-	19
FSU M12x125/50	$\leq 50$	21,5	21	19,3	20,5	12	125	208	-	19
FSU-P M10x100/20	$\geq 10 \leq 20$	19,3	19	17,5	18,5	10	120	148	20	17
FSU-P M12x125/30	$\geq 12 \leq 30$	21,5	21	19,3	20,5	12	155	188	30	19
FSU-P M12x125/50	$\geq 12 \leq 50$	21,5	21	19,3	20,5	12	175	208	50	19

**Table A2.2: Materials FSU**

Part	Designation	Material
		FSU, FSU-P
1	Cone bolt	Steel, zinc plated $\geq 5 \mu\text{m}$ according to EN ISO 4042:2018
2	Plastic sleeve	Plastic
3	Sleeve	Steel, zinc plated $\geq 5 \mu\text{m}$ according to EN ISO 4042:2018
4	Protective cap	Plastic
5	Washer	Steel, zinc plated $\geq 5 \mu\text{m}$ according to EN ISO 4042:2018
6	Hexagon nut	Steel, zinc plated $\geq 5 \mu\text{m}$ according to EN ISO 4042:2018

(Fig. not to scale)

fischer Strong Undercut Anchor FSU

**Product description**  
Product marking, dimensions and materials

**Annex A 2**

Appendix 4 / 16

## Stop drill bit FSU-SD

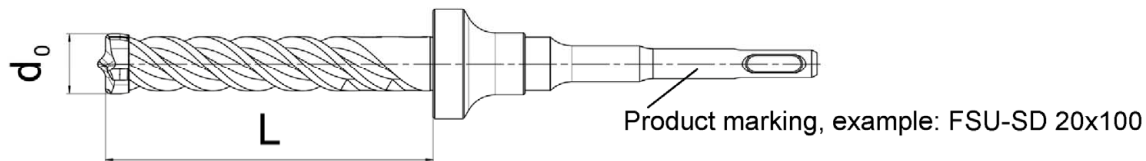

**Table A3.1:** Required stop drill bits for FSU

Type of anchor	Type of stop drill bit	d <sub>0</sub> [mm]	L [mm]
FSU M10x100/20	FSU-SD 20x100	20	107
FSU M12x125/30	FSU-SD 22x125	22	132
FSU M12x125/50			
FSU-P M10x100/20	FSU-SD 20x120	20	127
FSU-P M12x125/30	FSU-SD 22x155	22	162
FSU-P M12x125/50	FSU-SD 22x175	22	182

## Machine setting tool FSU-ST

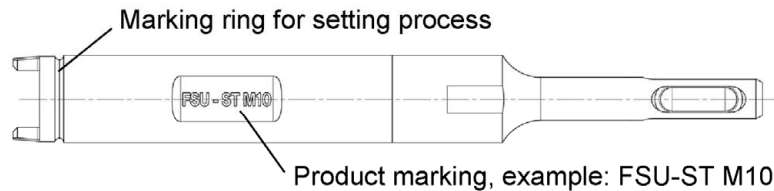

**Table A3.2:** Required setting tools for FSU

Type of anchor	Type of setting tool
FSU M10x100/20	FSU-ST M10
FSU M12x125/30	FSU-ST M12
FSU M12x125/50	
FSU-P M10x100/20	FSU-ST M10
FSU-P M12x125/30	FSU-ST M12
FSU-P M12x125/50	

**Table A3.3:** Recommendations for hammer drills used with FSU-ST

Technical feature	Recommendation
Drill chuck [-]	SDS plus
Hammer drilling RPM [rpm]	600 - 1800
Hammer impact energy [J]	2 - 5

(Fig. not to scale)

fischer Strong Undercut Anchor FSU

**Product description**  
Setting tools

**Annex A 3**

Appendix 5 / 16



## Specifications of intended use

### Fastenings subject to:

Size	FSU			FSU-P			
	M10x100 /20	M12x125 /30	M12x125 /50	M10x100 /20	M12x125 /30	M12x125 /50	
Static and quasi-static loads	✓						
Cracked and uncracked concrete							
Seismic performance category							C1
							C2
Fire exposure							

#### Base materials:

- Compacted reinforced and unreinforced normal weight concrete without fibres (cracked and uncracked) according to EN 206:2013+A2:2021
- Strength classes C20/25 to C50/60 according to EN 206:2013+A2:2021

#### Use conditions (Environmental conditions):

- Structures subject to dry internal conditions

#### Design:

- Anchorages are designed under the responsibility of an engineer experienced in anchorages and concrete work.
- Verifiable calculation notes and drawings are prepared taking account of the loads to be anchored. The position of the anchor is indicated on the design drawings (e.g. position of the anchor relative to reinforcement or to supports, etc.).
- Anchorages are designed in accordance with EN 1992-4:2018 and EOTA Technical Report TR 055:2018.
- For requirements to resistance to fire local spalling of the concrete cover must be avoided

fischer Strong Undercut Anchor FSU

**Intended Use**  
Specifications

**Annex B 1**

Appendix 6 / 16

# Installation parameters

**Table B2.1:** Installation parameters

Size	FSU			FSU-P		
	M10x100 /20	M12x125 /30	M12x125 /50	M10x100 /20	M12x125 /30	M12x125 /50
Nominal drill hole diameter	$d_0$	20	22	22	20	22
Cutting diameter of drill bits	$d_{cut} \leq$	20,5	22,5	22,5	20,5	22,5
Depth of drill hole to deepest point	$h_1 \geq$	107	132	132	127-t <sub>fix</sub>	182-t <sub>fix</sub>
Effective embedment depth	$h_{ef} \geq$	100	125	125	100	125
Diameter of clearance hole in the fixture	$d_f \leq$	12	14	14	21	23
Thickness of the fixture	t <sub>fix</sub>	≤ 20	≤ 30	≤ 50	≥ 10 ≤ 20	≥ 12 ≤ 30
Gap after setting	U	2 - 5	3 - 6	3 - 6	2 - 5	3 - 6
Required setting torque	T <sub>inst</sub> [Nm]	40	80	80	40	80

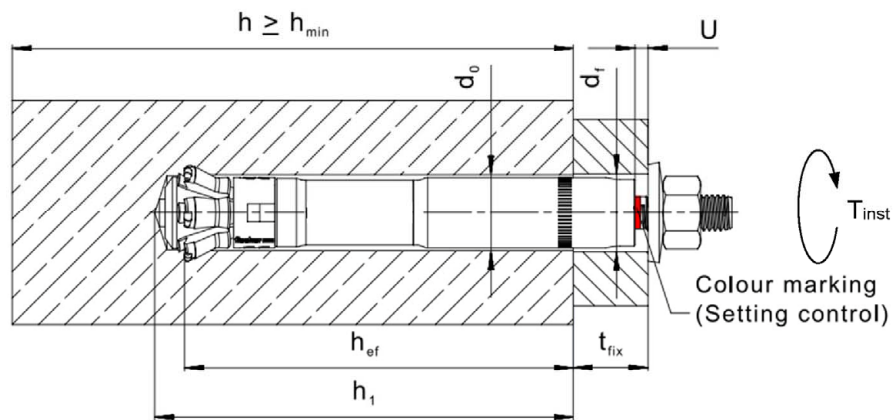
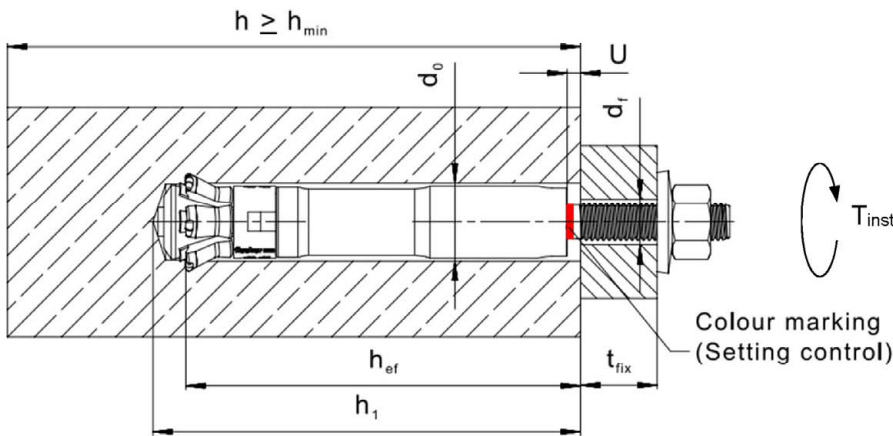

(Fig. not to scale)

fischer Strong Undercut Anchor FSU

**Intended Use**  
Installation parameters

**Annex B 2**

Appendix 7 / 16

## Installation instructions

- Fastener installation carried out by appropriately qualified personnel according to the design drawings and under the supervision of the person responsible for technical matters on the site.
- Use of the fastener only as supplied by the manufacturer without exchanging the components of the fastener.
- Fastener installation in accordance with the manufacturer's specifications and drawings and using the appropriate tools (machine setting tool FSU-ST, stop drill bit FSU-SD).
- Drill hole created perpendicular (tolerance +/- 5°) to concrete surface.
- Cleaning the hole of drilling dust.
- Fastener installation ensuring complete expansion of the sleeve with checking that the coloured ring marking on the bolt is visible above the top edge of the anchor sleeve, therefore it is required using the setting tool FSU-ST, that is the appropriate depth ring marking of the setting tool at least flush with the concrete surface (pre-setting) respecting with the fixture surface (Push-through-setting).
- Fastener installation ensuring complete shear load capacity, after setting the gap between the top edge of the sleeve and the concrete surface (pre-setting) or with surface of the fixture (Push-through-setting) has to be in the specified range according to Annex B 2, Table B2.1.
- Positioning of the drill holes and the undercut without damaging the reinforcement.
- In case of aborted hole: new drilling at a minimum distance twice the depth of the aborted drill hole or smaller distance, if the aborted drill hole is filled with high strength mortar and, if under shear or oblique tension load, it is not in the direction of load application.
- Application of the torque moment given in Annex B 2, Table B2.1 using a calibrated torque wrench.

fischer Strong Undercut Anchor FSU

**Intended Use**  
Installation instructions

**Annex B 3**

Appendix 8 / 16

## Installation instructions for pre-setting anchor FSU

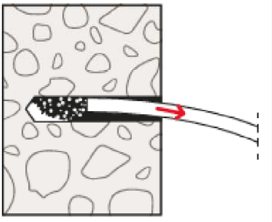
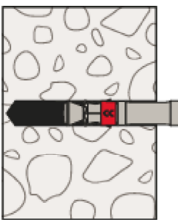
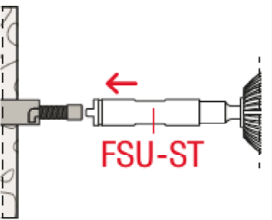
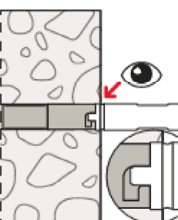
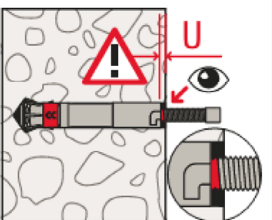
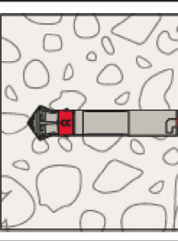
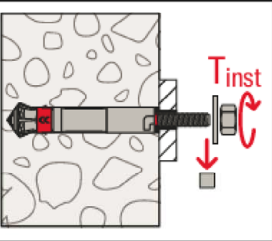
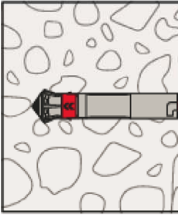
<p>1)</p> 	<p>2)</p> 	<ol style="list-style-type: none"> <li>1) Drill the hole with the designated stop drill bit FSU-SD (see Table A3.1).</li> <li>2) Clean the hole.</li> </ol>
<p>3)</p> 	<p>4)</p> 	<ol style="list-style-type: none"> <li>3) Place the anchor in the hole by hand. Do not use any hammering tools.</li> <li>4) Use the designated setting tool FSU-ST (see Table A3.2) and follow the recommendations for the hammer drill (see Table A3.3).</li> </ol>
<p>5)</p> 	<p>6)</p> 	<ol style="list-style-type: none"> <li>5) Place the setting tool in the grooves provided on the anchor. Carry out the setting process with the rotary-impact mode of the hammer drill. The setting process is completed when the marking ring of the setting tool is flush with the concrete surface.</li> <li>6) After removing the setting tool, the red coloured ring marking on the bolt must be visible above the top edge of the anchor sleeve. The gap U between the top edge of the sleeve and the concrete surface must be in the specified range according to Table B2.1.</li> </ol>
<p>7)</p> 	<p>8)</p> 	<ol style="list-style-type: none"> <li>7) Place the fixture.</li> <li>8) Remove the protective cap. Place the spring washer and the hexagon nut on the bolt. Take care of the right orientation of the spring washer, in the way, that the outer diameter of the washer in uncompressed condition is in touch with the fixture, only. Apply the installation torque.</li> </ol>
<p>9)</p> 		<ol style="list-style-type: none"> <li>9) Correctly installed fastener.</li> </ol>

fischer Strong Undercut Anchor FSU

**Intended Use**  
Installation instructions

**Annex B 4**

Appendix 9 / 16

## Installation instructions for push-through anchor FSU-P

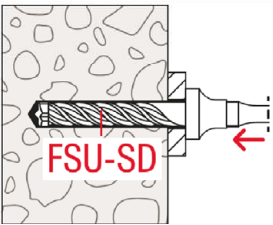
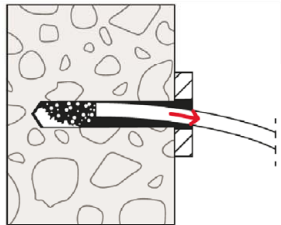
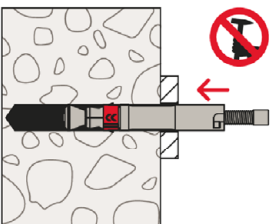
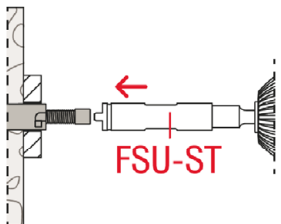
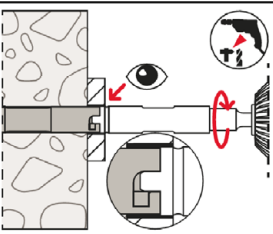
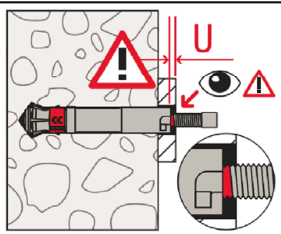
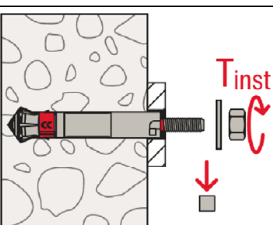
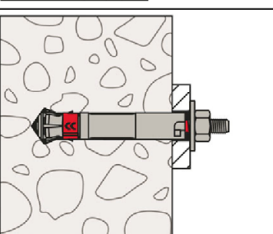
<p>1) </p>	<p>2) </p>	<ol style="list-style-type: none"> <li>1) Drill the hole with the designated stop drill bit FSU-SD (see table A3.1) in compliance with the specified range of fixture thicknesses (see Table B2.1).</li> <li>2) Clean the hole.</li> </ol>
<p>3) </p>	<p>4) </p>	<ol style="list-style-type: none"> <li>3) Place the anchor in the hole by hand. Do not use any hammering tools.</li> <li>4) Use the designated setting tool FSU-ST (see Table A3.2) and follow the recommendations for the hammer drill (see Table A3.3).</li> </ol>
<p>5) </p> <p>6) </p>		<ol style="list-style-type: none"> <li>5) Place the setting tool in the grooves provided on the anchor. Carry out the setting process with the rotary-impact mode of the hammer drill. The setting process is completed when the marking ring of the setting tool is flush with the fixture surface.</li> <li>6) After removing the setting tool, the red coloured ring marking on the bolt must be visible above the top edge of the anchor sleeve. The gap U between the top edge of the sleeve and the fixture surface must be in the specified range according to Table B2.1.</li> </ol>
<p>7) </p>		<ol style="list-style-type: none"> <li>7) Remove the protective cap. Place the spring washer and the hexagon nut on the bolt. Take care of the right orientation of the spring washer, in the way, that the outer diameter of the washer in uncompressed condition is in touch with the fixture, only. Apply the installation torque.</li> </ol>
<p>8) </p>		<ol style="list-style-type: none"> <li>8) Correctly installed fastener.</li> </ol>

fischer Strong Undercut Anchor FSU

**Intended Use**  
Installation instructions

**Annex B 5**

Appendix 10 / 16

**Table C1.1: Characteristic tension resistance under static and quasi-static action**

Size				FSU, FSU-P	
				M10x100	M12x125
<b>Steel failure</b>					
Characteristic resistance	$N_{Rk,s}$	[kN]	44,2	65,9	
Partial factor for steel failure	$\gamma_{Ms}$	[-]	1,5		
<b>Pullout failure</b>					
Characteristic resistance in C20/25	cracked concrete	$N_{Rk,p}$	[kN]	30,0	40,0
	uncracked concrete			44,2	65,9
Increasing factor for $N_{Rk,p}$ $N_{Rk,p} = \psi_c * N_{Rk,p} (C20/25)$	$\psi_c$ [-]	C25/30	1,12		
		C30/37	1,22		
		C35/45	1,32		
		C40/50	1,41		
		C45/55	1,50		
		C50/60	1,58		
Installation sensitivity factor	$\gamma_{inst}$	[-]	1,0		
<b>Concrete cone and splitting failure</b>					
Effective embedment depth	$h_{ef}$	[mm]	100	125	
Factor for cracked concrete	$k_{cr,N}$	[-]	8,9		
Factor for uncracked concrete	$k_{ucr,N}$		12,7		
Characteristic spacing	$s_{cr,N}$	[mm]	3 x $h_{ef}$		
Characteristic edge distance	$c_{cr,N}$		1,5 x $h_{ef}$		
Characteristic spacing	$s_{cr,sp}$		3 x $h_{ef}$		
Characteristic edge distance	$c_{cr,sp}$		1,5 x $h_{ef}$		
Characteristic resistance to splitting	$N^0_{Rk,sp}$		[kN]	$\min \{N^0_{Rk,c}; N_{Rk,p}\}^{1)}$	

<sup>1)</sup>  $N^0_{Rk,c}$  according to EN 1992-4:2018

fischer Strong Undercut Anchor FSU

**Performances**

Characteristic tension resistance under static and quasi-static action

**Annex C 1**

Appendix 11 / 16

**Table C2.1: Characteristic shear resistance under static and quasi-static action FSU**

Size			FSU	
			M10x100	M12x125
<b>Steel failure without lever arm</b>				
Characteristic resistance	$V_{RK,s}^0$	[kN]	26,8	38,2
Partial factor for steel failure	$\gamma_{Ms}$	[-]	1,25	
Factor for ductility	$k_7$		1,0	
<b>Steel failure with lever arm</b>				
Characteristic bending resistance	$M_{RK,s}^0$	[Nm]	59,8	104,8
Partial factor for steel failure	$\gamma_{Ms}$	[-]	1,25	
<b>Concrete pryout failure</b>				
Factor for pryout failure	$k_8$	[-]	2,0	
<b>Concrete edge failure</b>				
Effective length in concrete	$l_f$	[mm]	100	125
Effective diameter of fastener	$d_{nom}$		19	21

**Table C2.2: Characteristic shear resistance under static and quasi-static action FSU-P**

Size			FSU-P			
			M10x100		M12x125	
<b>Steel failure without lever arm</b>						
Characteristic resistance	for $t_{fix}$	[mm]	$10 \leq t_{fix} < 15$	$15 \leq t_{fix} \leq 20$	$12 \leq t_{fix} < 20$	$20 \leq t_{fix} \leq 50$
	$V_{RK,s}^0$	[kN]	66,1	69,6	86,4	96,7
Partial factor for steel failure	$\gamma_{Ms}$	[-]	1,25			
Factor for ductility	$k_7$		1,0			
<b>Steel failure with lever arm</b>						
Characteristic bending resistance	$M_{RK,s}^0$	[Nm]	59,8		104,8	
Partial factor for steel failure	$\gamma_{Ms}$	[-]	1,25			
<b>Concrete pryout failure</b>						
Factor for pryout failure	$k_8$		2,0			
<b>Concrete edge failure</b>						
Effective length in concrete	$l_f$	[mm]	100		125	
Effective diameter of fastener	$d_{nom}$		19		21	

fischer Strong Undercut Anchor FSU

**Performances**

Characteristic shear resistance under static and quasi-static action

**Annex C 2**

Appendix 12 / 16

**Table C3.1: Minimum thickness of concrete members FSU**

Size	FSU		
	M10x100/20	M12x125/30	M12x125/50
Minimum thickness of concrete member $h_{min}$ [mm]	170	215	

**Table C3.2: Minimum thickness of concrete members FSU-P**

Size	FSU-P		
	M10x100/20	M12x125/30	M12x125/50
Maximum thickness of the fixture $t_{fix,max}$ [mm]	20	30	50
Minimum thickness of concrete member $h_{min}$	$190-t_{fix}^{1)}$	$245-t_{fix}^{1)}$	$265-t_{fix}^{1)}$

<sup>1)</sup>  $t_{fix}$  = actual thickness of the fixture

**Table C3.3: Minimum spacings and edge distances**

Size	FSU, FSU-P		
	M10x100/20	M12x125/30	M12x125/50
Minimum spacing $s_{min}$ [mm]	80	90	
Minimum edge distance $c_{min}$	80	90	

fischer Strong Undercut Anchor FSU

**Performances**

Minimum thickness of concrete member, minimum spacings and edge distances

**Annex C 3**

Appendix 13 / 16



**Table C4.1: Characteristic tension resistance under fire exposure**

Size	FSU, FSU-P			
	M10x100	M12x125		
Characteristic resistance <b>steel failure</b>	$N_{Rk,s,fi}$	R30	3,7	4,5
		R60	2,2	3,2
		R90	1,7	2,8
		R120	1,5	2,6
Characteristic resistance <b>Concrete cone failure</b>	$N_{Rk,c,fi}$	R30-R90 [kN]	19,9	34,8
		R120	15,9	27,7
Characteristic resistance <b>pullout failure</b>	$N_{Rk,p,fi}$	R30-R90	7,5	10,0
		R120	6,0	8,0

**Table C4.2: Characteristic shear resistance under fire exposure**

Size	FSU, FSU-P			
	M10x100	M12x125		
Characteristic resistance <b>steel failure without lever arm</b>	$V_{Rk,s,fi}$	R30	3,7	4,4
		R60	2,2	3,0
		R90	1,7	2,6
		R120	1,5	2,3
Characteristic bending resistance <b>steel failure with lever arm</b>	$M^0_{Rk,s,fi}$	R30	4,8	6,9
		R60	2,9	5,0
		R90	2,2	4,4
		R120	1,9	4,0

Concrete pryout failure according to EN 1992-4:2018

**Table C4.3: Minimum spacings and minimum edge distances under fire exposure for tension and shear load**

Size	FSU, FSU-P
	<b>All sizes</b>
Spacing $s_{min,fi}$	$4 \cdot h_{ef}$
Edge distance $c_{min,fi}$ [mm]	$c_{min,fi} = 2 \cdot h_{ef}$ , for fire exposure from more than one side $c_{min,fi} \geq 300$ mm

fischer Strong Undercut Anchor FSU

**Performances**  
Characteristic resistance under fire exposure

**Annex C 4**

Appendix 14 / 16

**Table C5.1: Characteristic values of tension and shear resistance under seismic performance category C1**

Size	FSU, FSU-P				
	M10x100		M12x125		
Factor for annular gap Without filling of annular gap $\alpha_{gap}$ [-]	0,5				
<b>Steel failure</b>					
Characteristic resistance tension load C1 $N_{Rk,s,C1}$ [kN]	44,2		65,9		
<b>Pullout failure</b>					
Characteristic resistance tension load in cracked concrete C1 $N_{Rk,p,C1}$ [kN]	30,0		40,0		
<b>Steel failure without lever arm</b>					
Characteristic resistance shear load C1 $V_{Rk,s,C1}$ [kN]	for $t_{fix}$ [mm]	$10 \leq t_{fix} < 15$	$15 \leq t_{fix} \leq 20$	$12 \leq t_{fix} < 20$	$20 \leq t_{fix} \leq 50$
	$V_{Rk,s,C1}$ FSU	18,8		26,8	
	$V_{Rk,s,C1}$ FSU-P	46,3	48,7	60,5	67,7

**Table C5.2: Characteristic values of tension and shear resistance under seismic performance category C2**

Size	FSU, FSU-P				
	M10x100		M12x125		
Factor for annular gap Without filling of annular gap $\alpha_{gap}$ [-]	0,5				
<b>Steel failure</b>					
Characteristic resistance tension load C2 $N_{Rk,s,C2}$ [kN]	44,2		65,9		
<b>Pullout failure</b>					
Characteristic resistance tension load in cracked concrete C2 $N_{Rk,p,C2}$ [kN]	30,0		40,0		
<b>Steel failure without lever arm</b>					
Characteristic resistance shear load C2 $V_{Rk,s,C2}$ [kN]	for $t_{fix}$ [mm]	$10 \leq t_{fix} < 15$	$15 \leq t_{fix} \leq 20$	$12 \leq t_{fix} < 20$	$20 \leq t_{fix} \leq 50$
	$V_{Rk,s,C2}$ FSU	20,1		24,5	
	$V_{Rk,s,C2}$ FSU-P	39,6	41,8	51,8	62,9

fischer Strong Undercut Anchor FSU

**Performances**

Characteristic resistance under seismic performance categories C1 and C2

**Annex C 5**

Appendix 15 / 16

**Table C6.1: Displacements under static and quasi-static tension loads**

Size			FSU, FSU-P	
			M10x100	M12x125
Tension load in cracked concrete C20/25	N	[kN]	22,1	32,1
Displacements	$\frac{\delta_{N0}}{\delta_{N\infty}}$	[mm]	1,1	1,3
			2,8	3,0
Tension load in uncracked concrete C20/25	N	[kN]	22,1	32,1
Displacements	$\frac{\delta_{N0}}{\delta_{N\infty}}$	[mm]	1,1	1,3
			2,3	2,3

**Table C6.2: Displacements under static and quasi-static shear loads**

Size			FSU, FSU-P	
			M10x100	M12x125
Shear load in cracked and uncracked concrete C20/25	V	[kN]	13,8	21,3
Displacements FSU	$\frac{\delta_{V0}}{\delta_{V\infty}}$	[mm]	5,4	6,7
			8,0	10,0
Shear load in cracked and uncracked concrete C20/25	V	[kN]	36,3	52,2
Displacements FSU-P	$\frac{\delta_{V0}}{\delta_{V\infty}}$	[mm]	5,9	7,2
			8,8	10,7

**Table C6.3: Displacements under tension loads for seismic performance category C2**

Size			FSU, FSU-P	
			M10x100	M12x125
Displacement	DLS	$\delta_{N,C2}$ [mm]	4,6	4,6
	ULS		11,4	10,4

**Table C6.4: Displacements under shear loads for seismic performance category C2**

Size			FSU, FSU-P	
			M10x100	M12x125
Displacement FSU	DLS	$\delta_{V,C2}$ [mm]	5,2	5,0
	ULS		7,3	6,7
Displacement FSU-P	DLS	$\delta_{V,C2}$ [mm]	4,8	5,0
	ULS		10,7	18,5

fischer Strong Undercut Anchor FSU

**Performances**  
Displacement under tension and shear loads

**Annex C 6**

Appendix 16 / 16