

## ΔΗΛΩΣΗ ΕΠΙΔΟΣΕΩΝ

### DoP 0319

για το σύστημα έκχυσης fischer FIS P Plus (χημικό αγκύριο για χρήση σε σκυρόδεμα)

EL

- Μοναδικός κωδικός ταυτοποίησης του τύπου του προϊόντος: DoP 0319
- Προβλεπόμενη(-ες) χρήση(-εις): Μεταγενέστερη στερέωση σε μη ρηγματωμένο σκυρόδεμα, δείτε το παράρτημα, ειδικά τα παραρτήματα B1 - B7.
- Κατασκευαστής: fischerwerke GmbH & Co. KG, Otto-Hahn-Straße 15, 79211 Denzlingen, Γερμανία
- Εξουσιοδοτημένος αντιπρόσωπος: -
- Σύστημα/συστήματα AVCP (αξιολόγηση και επαλήθευση της σταθερότητας της επίδοσης): 1
- Ευρωπαϊκό έγγραφο αξιολόγησης: EAD 330499-00-0601  
Ευρωπαϊκή τεχνική αξιολόγηση: ETA-18/0383; 2018-09-06  
Οργανισμός τεχνικής αξιολόγησης: DIBt- Deutsches Institut für Bautechnik  
Κοινοποιημένος(-οι) οργανισμός(-οι): 2873 TU Darmstadt
- Δηλωθείσα(-ες) επίδοση(-εις):  
**Μηχανική αντίσταση και σταθερότητα (BWR1)**  
**Χαρακτηριστική αντίσταση σε εφελκυστικό φορτίο (στατικό και σχεδόν στατικό):**  
Αντίσταση σε αστοχία χάλυβα: Παράρτημα C1  
Αντίσταση για συνδυασμένη αστοχία από ολίσθηση και κώνο σκυροδέματος: Παράρτημα C3  
Αντίσταση σε αστοχία από κώνο σκυροδέματος: Παράρτημα C2  
Απόσταση από ακμή για αποφυγή θραύσης από φορτίο: Παράρτημα C2  
Ανθεκτικότητα: Παραρτήματα C2, C3  
Μέγιστη ροπή σύσφιξης: Παράρτημα B3  
Ελάχιστη απόσταση από ακμή και μεταξύ αγκυριών: Παράρτημα B3  
  
**Χαρακτηριστική αντίσταση σε διατμητικό φορτίο (στατικό και σχεδόν στατικό):**  
Αντίσταση σε αστοχία χάλυβα: Παράρτημα C1  
Αντίσταση σε ολίσθηση: Παράρτημα C2  
Αντίσταση σε αστοχία ακμής σκυροδέματος: Παράρτημα C2  
  
**Μετατόπιση σε βραχείας διάρκειας και μακράς διάρκειας φόρτιση:**  
Μετατόπιση σε βραχείας διάρκειας και μακράς διάρκειας φόρτιση: Παράρτημα C3  
  
**Χαρακτηριστική αντίσταση και μετακινήσεις για τις σεισμικές κατηγορίες C1 και C2 (προαιρετικά):**  
Αντίσταση σε αστοχία χάλυβα: NPD  
Αντίσταση σε αστοχία από εξόγκευση: NPD  
Επιμήκυνση διαρροής: NPD  
Παράμετρος περιμετρικού κενού: NPD  
Μετακινήσεις: NPD  
  
**Υγιεινή, υγεία και περιβάλλον (BWR 3)**  
Περιεχόμενο, εκπομπή ή/και απελευθέρωση επικίνδυνων ουσιών: NPD
- Κατάλληλη τεχνική τεκμηρίωση και/ή ειδική τεχνική τεκμηρίωση: -

$k_{cr,N} = \text{NPD}$

Η επίδοση του προϊόντος που ταυτοποιείται ανωτέρω είναι σύμφωνη με τη (τις) δηλωθείσα(-ες) επίδοση(-εις). Αυτή η δήλωση επιδόσεων εκδίδεται σύμφωνα με τον Κανονισμό (ΕΕ) Αρ. 305/2011 με αποκλειστική ευθύνη του κατασκευαστή που προσδιορίζεται παραπάνω.

Υπογραφή για λογαριασμό και εξ ονόματος του κατασκευαστή από:



Dr.-Ing. Oliver Geibig, Γενικός Διευθυντής Επιχειρηματικών Μονάδων & Μηχανικής  
Tumlingen, 2024-01-21

Jürgen Grün, Γενικός Διευθυντής Χημικών & Ποιότητας

Αυτή η Δήλωση Επιδόσεων μεταφράστηκε σε διάφορες γλώσσες. Σε περίπτωση που υπάρχει αμφιβολία για τη μετάφραση, υπερισχύει πάντα η αγγλική έκδοση.

Το παράρτημα περιλαμβάνει προαιρετικές και συμπληρωματικές πληροφορίες στα αγγλικά, που ξεπερνούν τις (οριζόμενες σε άλλες γλώσσες) νόμιμες απαιτήσεις.

## Specific Part

### 1 Technical description of the product

The fischer injection system FIS P Plus is a bonded anchor consisting of a cartridge with injection mortar fischer FIS P Plus and a steel element according to Annex A 3.

The steel element is placed into a drilled hole filled with injection mortar and is anchored via the bond between metal part, injection mortar and concrete.

The product description is given in Annex A.

### 2 Specification of the intended use in accordance with the applicable European Assessment Document

The performances given in Section 3 are only valid if the anchor is used in compliance with the specifications and conditions given in Annex B.

The verifications and assessment methods on which this European Technical Assessment is based lead to the assumption of a working life of the anchor of at least 50 years. The indications given on the working life cannot be interpreted as a guarantee given by the producer, but are to be regarded only as a means for choosing the right products in relation to the expected economically reasonable working life of the works.

### 3 Performance of the product and references to the methods used for its assessment

#### 3.1 Mechanical resistance and stability (BWR 1)

Essential characteristic	Performance
Characteristic resistance to tension load (static and quasi-static loading)	See Annex C 1 to C 3
Characteristic resistance to shear load (static and quasi-static loading)	See Annex C 1 and C 2
Displacements (static and quasi-static loading)	See Annex C 3
Characteristic resistance and displacements for seismic performance categories C1 and C2	No performance assessed

#### 3.2 Hygiene, health and the environment (BWR 3)

Essential characteristic	Performance
Content, emission and/or release of dangerous substances	No performance assessed

### 4 Assessment and verification of constancy of performance (AVCP) system applied, with reference to its legal base

In accordance with the European Assessment Document EAD 330499-00-0601 the applicable European legal act is: [96/582/EC].

The system to be applied is: 1

# Installation conditions part 1

## fischer anchor rod

### Pre positioned installation

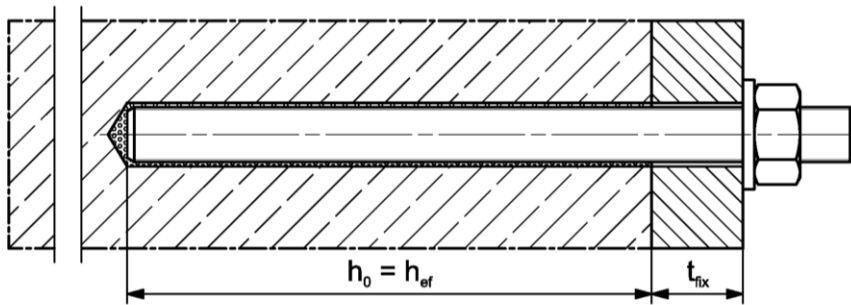

### Push through installation (annular gap filled with mortar)

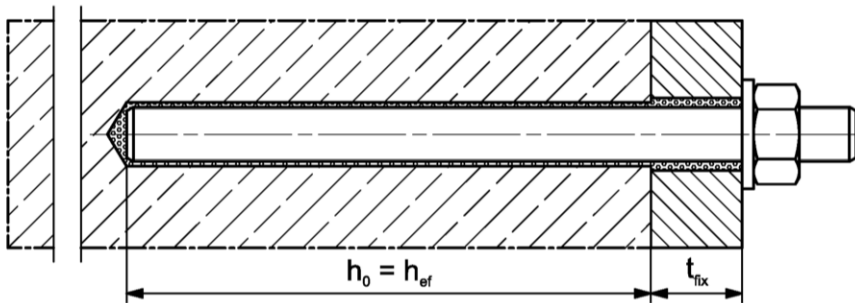

### Pre-positioned or push through installation with subsequently pressed filling disk (annular gap filled with mortar)

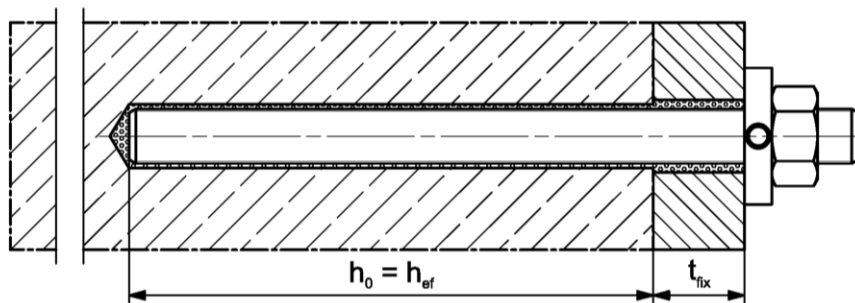

Figures not to scale

$h_0$  = drill hole depth

$h_{ef}$  = effective embedment depth

$t_{fix}$  = thickness of fixture

fischer injection system FIS P Plus

**Product description**  
Installation conditions part 1

**Annex A 1**

Appendix 2 / 15

## Overview system components part 1

**Injection cartridge (shuttle cartridge) with sealing cap; Size: 345 ml, 360 ml, 390 ml, 550 ml, 950 ml, 1500 ml**

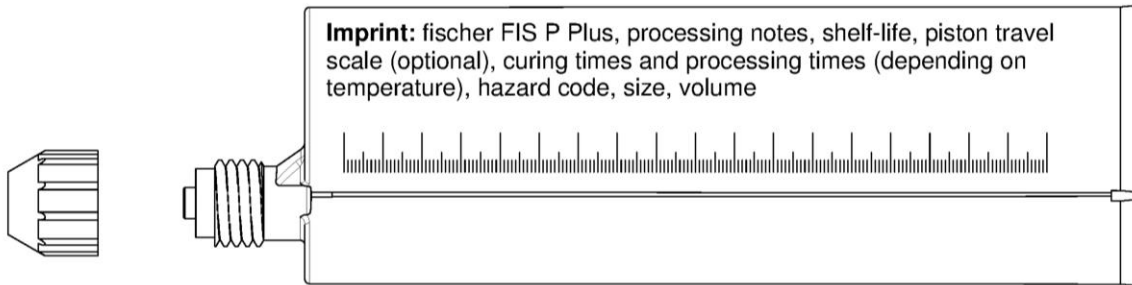

**Injection cartridge (coaxial cartridge) with sealing cap; Size: 100 ml, 150 ml, 300 ml, 380 ml, 400 ml, 410 ml**

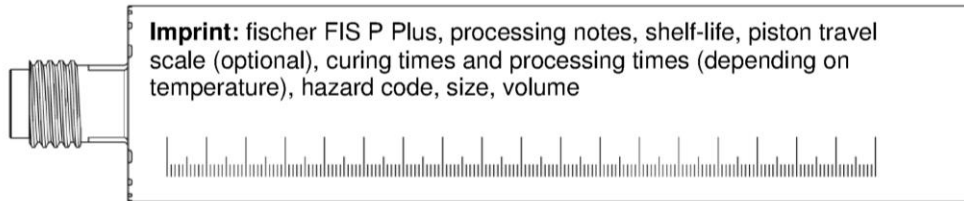

**Static mixer FIS MR Plus or UMR**

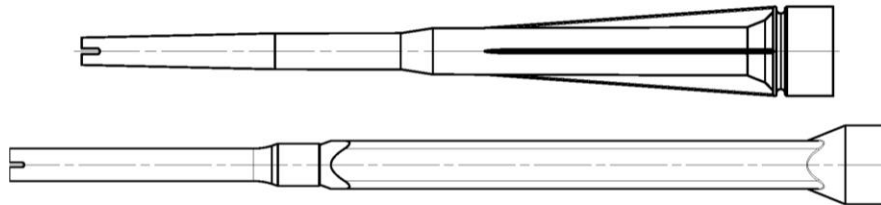

**Injection adapter and Extension tube for static mixer**



**Cleaning brush BS / BSB**



**Blow-out pump ABG or ABP**



Figures not to scale

fischer injection system FIS P Plus

### System description

Overview system components part 1;  
cartridges / static mixer / accessories

**Annex A 2**

Appendix 3 / 15

## Overview system components part 2

### fischer anchor rod

Size: M8, M10, M12, M16, M20 ,M24

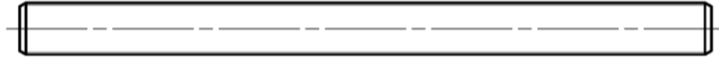

### washer / hexagon nut

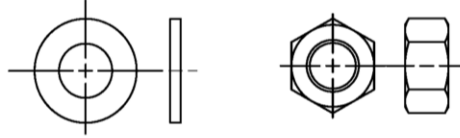

### fischer filling disk FFD with injection adapter

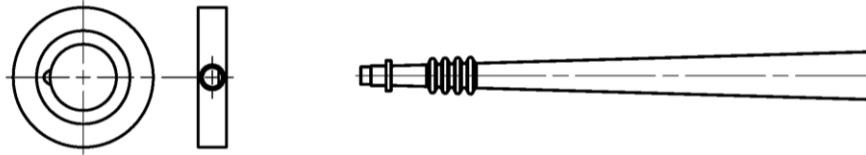

Figures not to scale

fischer injection system FIS P Plus

### System description

Overview system components part 2;  
steel components

**Annex A 3**

Appendix 4 / 15

**Table A4.1: Materials**

Part	Designation	Material		
1	Injection cartridge	Mortar, hardener, filler		
	Steel grade	Steel, zinc plated	Stainless steel A4	High corrosion resistant steel C
2	Anchor rod	Property class 5.8 or 8.8; EN ISO 898-1:2013 zinc plated $\geq 5 \mu\text{m}$ , EN ISO 4042:1999 A2K or hot-dip galvanized $\geq 40 \mu\text{m}$ EN ISO 10684:2004 $f_{uk} \leq 1000 \text{ N/mm}^2$ $A_5 > 8\%$ fracture elongation	Property class 50, 70 or 80 EN ISO 3506-1:2009 1.4401; 1.4404; 1.4578; 1.4571; 1.4439; 1.4362; 1.4062, 1.4662, 1.4462; EN 10088-1:2014 $f_{uk} \leq 1000 \text{ N/mm}^2$ $A_5 > 8\%$ fracture elongation	Property class 50 or 80 EN ISO 3506-1:2009 or property class 70 with $f_{yk} = 560 \text{ N/mm}^2$ 1.4565; 1.4529; EN 10088-1:2014 $f_{uk} \leq 1000 \text{ N/mm}^2$ $A_5 > 8\%$ fracture elongation
3	Washer ISO 7089:2000	zinc plated $\geq 5 \mu\text{m}$ , EN ISO 4042:1999 A2K or hot-dip galvanized $\geq 40 \mu\text{m}$ EN ISO 10684:2004	1.4401; 1.4404; 1.4578; 1.4571; 1.4439; 1.4362; EN 10088-1:2014	1.4565; 1.4529; EN 10088-1:2014
4	Hexagon nut	Property class 5 or 8; EN ISO 898-2:2012 zinc plated $\geq 5 \mu\text{m}$ , ISO 4042:1999 A2K or hot-dip galvanized $\geq 40 \mu\text{m}$ EN ISO 10684:2004	Property class 50, 70 or 80 EN ISO 3506-1:2009 1.4401; 1.4404; 1.4578; 1.4571; 1.4439; 1.4362; EN 10088-1:2014	Property class 50, 70 or 80 EN ISO 3506-1:2009 1.4565; 1.4529 EN 10088-1:2014
5	fischer filling disk FFD similar to DIN 6319-G	zinc plated $\geq 5 \mu\text{m}$ , EN ISO 4042:1999 A2K or hot-dip galvanized $\geq 40 \mu\text{m}$ EN ISO 10684:2004	1.4401; 1.4404; 1.4578; 1.4571; 1.4439; 1.4362; EN 10088-1:2014	1.4565; 1.4529; EN 10088-1:2014

fischer injection system FIS P Plus



**Product description**  
Materials

**Annex A 4**

Appendix 5 / 15

## Specifications of intended use (part 1)

**Table B1.1:** Overview use and performance categories

Anchorages subject to		<b>FIS P Plus with ...</b>	
		Anchor rod 	
Hammer drilling with standard drill bit		all sizes	
Hammer drilling with hollow drill bit (Heller "Duster Expert"; Bosch „Speed Clean“; Hilti "TE-CD, TE-YD")		Nominal drill bit diameter ( $d_0$ ) 12 mm to 28 mm	
Static and quasi static load, in	uncracked concrete	all sizes	Tables: C1.1 C2.1 C3.1 C3.2
Use category	I1	dry or wet concrete	all sizes
	I2	Flooded hole	M12 to M24
Installation direction		D3 (downward and horizontal and upwards (e.g. overhead) installation)	
Installation temperature		$T_{i,min} = 0\text{ °C}$ to $T_{i,max} = +40\text{ °C}$	
In-service temperature	Temperature range I	-40 °C to +40 °C	(max. short term temperature +40 °C ; max. long term temperature +24 °C)
	Temperature range II	-40 °C to +80 °C	(max. short term temperature +80 °C ; max. long term temperature +50 °C)

fischer injection system FIS P Plus

**Intended use**  
Specifications (part 1)

**Annex B 1**

Appendix 6 / 15

## Specifications of intended use (part 2)

### Base materials:

- Compacted reinforced or unreinforced normal weight concrete without fibres of strength classes C20/25 to C50/60 according to EN 206:2013

### Use conditions (Environmental conditions):

- Structures subject to dry internal conditions (zinc coated steel, stainless steel or high corrosion resistant steel)
- Structures subject to external atmospheric exposure (including industrial and marine environment) and to permanently damp internal condition, if no particular aggressive conditions exist (stainless steel or high corrosion resistant steel)
- Structures subject to external atmospheric exposure, to permanently damp internal conditions or in other particular aggressive conditions (high corrosion resistant steel)

Note: Particular aggressive conditions are e. g. permanent, alternating immersion in seawater or the splash zone of seawater, chloride atmosphere of indoor swimming pools or atmosphere with extreme chemical pollution (e. g. in desulphurization plants or road tunnels where de-icing materials are used)

### Design:

- Anchorages have to be designed by a responsible engineer with experience of concrete anchor design.
- Verifiable calculation notes and drawings are to be prepared taking account of the loads to be anchored. The position of the anchor is indicated on the design drawings (e. g. position of the anchor relative to reinforcement or to supports, etc.)
- Anchorages are designed in accordance with FprEN 1992-4:2017 and EOTA Technical Report TR 055

### Installation:

- Anchor installation is to be carried out by appropriately qualified personnel and under the supervision of the person responsible for technical matters of the site
- In case of aborted hole: The hole shall be filled with mortar
- Anchorage depth should be marked and adhered to on installation
- Overhead installation is allowed

fischer injection system FIS P Plus

**Intended use**  
Specifications (part 2)

**Annex B 2**

Appendix 7 / 15



**Table B3.1:** Installation parameters plus minimum spacing and minimum edge distance for anchor rods

Anchor rods		Thread	M8	M10	M12	M16	M20	M24
Width across flats	SW	[mm]	13	17	19	24	30	36
Nominal drill hole diameter	$d_0$		10	12	14	18	24	28
Drill hole depth	$h_0$		$h_0 = h_{ef}$					
Effective embedment depth	$h_{ef, min}$		60	60	70	80	90	96
	$h_{ef, max}$		160	200	240	320	400	480
Minimum spacing and minimum edge distance	$s_{min}$ = $c_{min}$		40	45	55	65	85	105
	Diameter of the clearance hole of the fixture		pre positioned installation $d_f$	9	12	14	18	22
push through installation $d_f$			11	14	16	20	26	30
Minimum thickness of concrete member	$h_{min}$		$h_{ef} + 30 (\geq 100)$			$h_{ef} + 2d_0$		
Maximum torque moment for attachment of the fixture	$\max T_{fix}$		[Nm]	10	20	40	60	120

**fischer anchor rod**

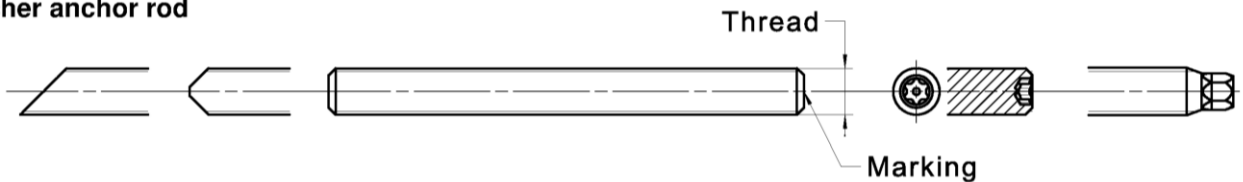

**Marking (on random place) fischer anchor rod:**

Property class 8.8, stainless steel, property class 80 and high corrosion resistant steel, property class 80: •  
 Stainless steel A4, property class 50 and high corrosion resistant steel, property class 50: ••  
 Alternatively: Colour coding according to DIN 976-1

**Installation conditions:**

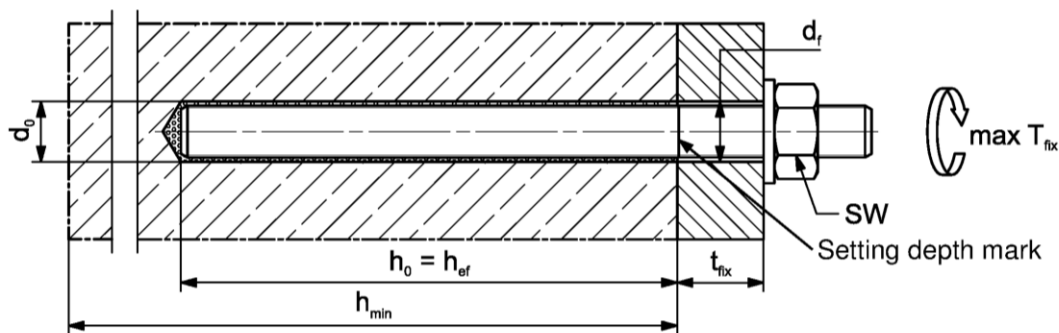

**Commercial standard threaded rods, washers and hexagon nuts may also be used if the following requirements are fulfilled**

- Materials, dimensions and mechanical properties according to Annex A 4, Table A4.1
- Inspection certificate 3.1 according to EN 10204:2004, the documents have to be stored
- Setting depth is marked

Figures not to scale

fischer injection system FIS P Plus

**Intended use**  
 Installation parameters anchor rods

**Annex B 3**

Appendix 8 / 15

**Table B4.1:** Parameters of the cleaning brush BS (steel brush)

The size of the cleaning brush refers to the drill hole diameter

Nominal drill hole diameter	$d_0$	[mm]	10	12	14	18	24	28
Steel brush diameter	$d_b$		11	14	16	20	26	30



**Table B4.2** Maximum processing time of the mortar and minimum curing time  
(During the curing time of the mortar the concrete temperature may not fall below the listed minimum temperature)

Temperature at anchoring base [°C]	Maximum processing time $t_{work}$	Minimum curing time $t_{cure}$
>±0 to +5	13 min	3 h
>+5 to +10	9 min	90 min
>+10 to +20	5 min	60 min
>+20 to +30	4 min	45 min
>+30 to +40	2 min	35 min

<sup>1)</sup> In wet concrete or water filled holes the curing times must be doubled

fischer injection system FIS P Plus

**Intended use**

Cleaning brush (steel brush)  
Processing time and curing time

**Annex B 4**

Appendix 9 / 15

## Installation instructions part 1

### Drilling and cleaning the hole (hammer drilling with standard drill bit)

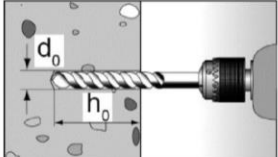
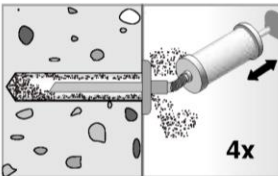
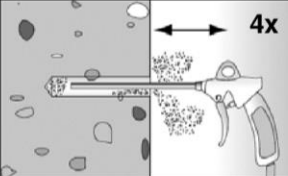
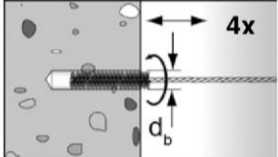
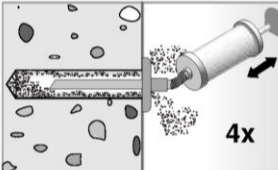
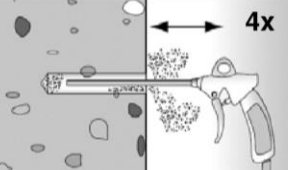
1		<p>Drill the hole. Nominal drill hole diameter <math>d_0</math> and drill hole depth <math>h_0</math> see <b>tables B3.1</b></p>	
2		<p>Clean the drill hole: For <math>h_{ef} \leq 12d</math> and <math>d_0 &lt; 18</math> mm blow out the hole four times by hand</p>	 <p>For <math>h_{ef} &gt; 12d</math> and / or <math>d_0 \geq 18</math> mm blow out the hole four times with oil-free compressed air (<math>p \geq 6</math> bar)</p>
3		<p>Brush the drill hole four times. For deep holes use an extension. Corresponding brushes see <b>table B4.1</b></p>	
4		<p>Clean the drill hole: For <math>h_{ef} \leq 12d</math> and <math>d_0 &lt; 18</math> mm blow out the hole four times by hand</p>	 <p>For <math>h_{ef} &gt; 12d</math> and / or <math>d_0 \geq 18</math> mm blow out the hole four times with oil-free compressed air (<math>p \geq 6</math> bar)</p>

Go to step 5

### Drilling and cleaning the hole (hammer drilling with hollow drill bit)

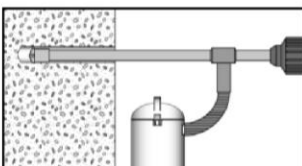
1		<p>Check a suitable hollow drill (see <b>table B1.1</b>) for correct operation of the dust extraction</p>
2		<p>Use a suitable dust extraction system, e. g. Bosch GAS 35 M AFC or a comparable dust extraction system with equivalent performance data</p> <p>Drill the hole with hollow drill bit. The dust extraction system has to extract the drill dust nonstop during the drilling process and must be adjusted to maximum power. Nominal drill hole diameter <math>d_0</math> and drill hole depth <math>h_0</math> see <b>tables B3.1</b></p>

Go to step 5

fischer injection system FIS P Plus



**Intended use**  
Installation instructions part 1

**Annex B 5**

Appendix 10 / 15

## Installation instructions part 2

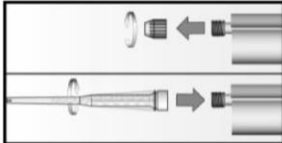
### Preparing the cartridge

5		<p>Remove the sealing cap</p> <p>Screw on the static mixer (the spiral in the static mixer must be clearly visible)</p>
6		<p>Place the cartridge into the dispenser</p>
7		<p>Extrude approximately 10 cm of material out until the resin is evenly grey in colour. Do not use mortar that is not uniformly grey</p>

### Injection of the mortar

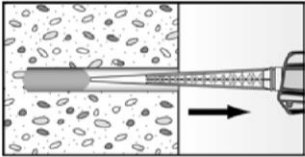
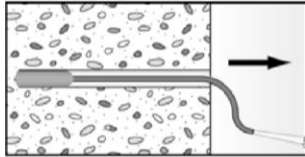
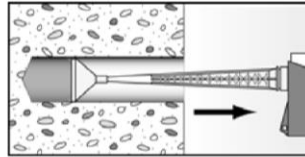
8	 <p>Fill approximately 2/3 of the drill hole with mortar. Always begin from the bottom of the hole and avoid bubbles</p>	 <p>For drill hole depth <math>\geq 150</math> mm use an extension tube</p>	 <p>For overhead installation, deep holes (<math>h_0 &gt; 250</math> mm) use an injection-adapter</p>
---	-----------------------------------------------------------------------------------------------------------------------------------------------------------------------------------------------------------	--------------------------------------------------------------------------------------------------------------------------------------------------------------	------------------------------------------------------------------------------------------------------------------------------------------------------------------------------------------

fischer injection system FIS P Plus



**Intended use**  
Installation instructions part 2

**Annex B 6**

Appendix 11 / 15

# Installation instructions part 3

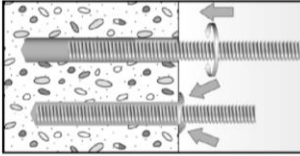
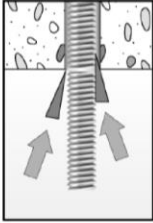
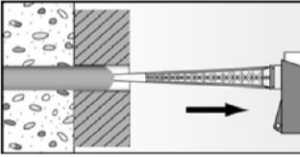
## Installation of anchor rods

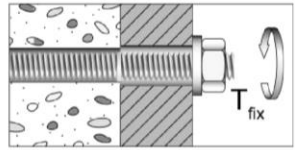
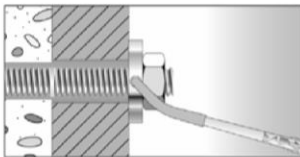
9		<p>Only use clean and oil-free anchor elements.          Mark the setting depth of the anchor. Push the anchor rod down to the bottom of the hole, turning it slightly while doing so.          After inserting the anchor element, excess mortar must be emerged around the anchor element.</p>
	 <p>For overhead installations support the anchor rod with wedges.          (e. g. fischer centering wedges)</p>	 <p>For push through installation fill the annular gap with mortar</p>
10	 <p>Wait for the specified curing time <math>t_{cure}</math> see <b>table B4.2</b></p>	<p>11</p>  <p>Mounting the fixture          max <math>T_{fix}</math> see <b>tables B3.1</b></p>
Option		<p>After the minimum curing time is reached, the gap between anchor and fixture (annular clearance) may be filled with mortar via the fischer filling disc FFD. Compressive strength <math>\geq 50 \text{ N/mm}^2</math> (e.g. fischer injection mortars FIS HB, FIS SB, FIS V, FIS EM Plus, FIS P Plus)  <b>ATTENTION:</b> Using fischer filling disc FFD reduces <math>t_{fix}</math> (usable length of the anchor)</p>

fischer injection system FIS P Plus

**Intended use**  
 Installation instructions part 3

**Annex B 7**

Appendix 12 / 15

**Table C1.1:** Essential characteristic for the **steel bearing capacity** under tensile / shear load of **fischer anchor rods** and **standard threaded rods**

Anchor rod / standard threaded rod		M8	M10	M12	M16	M20	M24			
<b>Bearing capacity under tensile load, steel failure<sup>3)</sup></b>										
Characteristic resistance $N_{Rk,s}$	Steel zinc plated	5.8	Property class	[kN]	19 (17)	29 (27)	43	79	123	177
		8.8			29 (27)	47 (43)	68	126	196	282
	Stainless steel A4 and high corrosion resistant steel C	50			19	29	43	79	123	177
		70			26	41	59	110	172	247
		80			30	47	68	126	196	282
<b>Partial factors<sup>1)</sup></b>										
Partial factor $\gamma_{Ms,N}$	Steel zinc plated	5.8	Property class	[-]	1,50					
		8.8			1,50					
	Stainless steel A4 and high corrosion resistant steel C	50			2,86					
		70			1,50 <sup>2)</sup> / 1,87					
		80			1,60					
<b>Bearing capacity under shear load, steel failure without lever arm<sup>3)</sup></b>										
Characteristic resistance $V_{Rk,s}^0$	Steel zinc plated	5.8	Property class	[kN]	9 (8)	15 (13)	21	39	61	89
		8.8			15 (13)	23 (21)	34	63	98	141
	Stainless steel A4 and high corrosion resistant steel C	50			9	15	21	39	61	89
		70			13	20	30	55	86	124
		80			15	23	34	63	98	141
Ductility factor	$k_7$	[-]	1,0							
<b>with lever arm<sup>3)</sup></b>										
Charact. resistance $M_{Rk,s}^0$	Steel zinc plated	5.8	Property class	[Nm]	19 (16)	37 (33)	65	166	324	560
		8.8			30 (26)	60 (53)	105	266	519	896
	Stainless steel A4 and high corrosion resistant steel C	50			19	37	65	166	324	560
		70			26	52	92	232	454	784
		80			30	60	105	266	519	896
<b>Partial factors<sup>1)</sup></b>										
Partial factor $\gamma_{Ms,V}$	Steel zinc plated	5.8	Property class	[-]	1,25					
		8.8			1,25					
	Stainless steel A4 and high corrosion resistant steel C	50			2,38					
		70			1,25 <sup>2)</sup> / 1,56					
		80			1,33					

<sup>1)</sup> In absence of other national regulations

<sup>2)</sup> Only admissible for steel C, with  $f_{yk} / f_{uk} \geq 0,8$  and  $A_5 > 12 \%$  (e.g. fischer anchor rods)

<sup>3)</sup> Values in brackets are valid for undersized threaded rods with smaller stress area  $A_s$  for hotdip galvanised standard threaded rods according to EN ISO 10684:2004+AC:2009.

fischer injection steel system FIS P Plus

**Performances**

Essential characteristics for the steel bearing capacity of fischer anchor rods and standard threaded rods

**Annex C 1**

Appendix 13 / 15

<b>Table C2.1:</b> Essential characteristics under tensile / shear load									
<b>Size</b>			<b>All sizes</b>						
<b>Tensile load</b>									
Uncracked concrete		$k_{Ucr,N}$	[-]	11,0					
<b>Factors for the compressive strength of concrete &gt; C20/25</b>									
Increasing factor for $\tau_{Rk}$	C25/30		$\Psi_c$	[-]	1,05				
	C30/37				1,10				
	C35/45				1,15				
	C40/50				1,19				
	C45/55				1,22				
	C50/60				1,26				
<b>Splitting failure</b>									
Edge distance	$h / h_{ef} \geq 2,0$		$c_{cr,sp}$	[mm]	1,0 $h_{ef}$				
	$2,0 > h / h_{ef} > 1,3$				4,6 $h_{ef}$ - 1,8 h				
	$h / h_{ef} \leq 1,3$				2,26 $h_{ef}$				
Spacing		$s_{cr,sp}$	2 $c_{cr,sp}$						
<b>Concrete cone failure</b>									
Edge distance		$c_{cr,N}$	[mm]	1,5 $h_{ef}$					
Spacing		$s_{cr,N}$		2 $c_{cr,N}$					
Installation factor tensile load		$\gamma_{inst}$	[-]	1,2					
<b>Shear load</b>									
Installation factor shear load		$\gamma_{inst}$	[-]	1,0					
<b>Concrete pry-out failure</b>									
Factor for pry-out failure		$k_g$	[-]	2,0					
<b>Calculation diameters</b>									
Size			M8	M10	M12	M16	M20	M24	
fisher anchor rods and standard threaded rods		$d_{nom}$	[mm]	8	10	12	16	20	24
fisher injection system FIS P Plus							<b>Annex C 2</b> Appendix 14 / 15		
<b>Performances</b> Essential characteristics under tensile / shear load									

**Table C3.1:** Essential characteristics of **tensile resistance** for **fischer anchor rods** and **standard threaded rods** in hammer drilled holes; **uncracked concrete**

Anchor rod / standard threaded rod		M8	M10	M12	M16	M20	M24		
<b>Combined pullout and concrete cone failure</b>									
Calculation diameter	d	[mm]	8	10	12	16	20	24	
<b>Uncracked concrete</b>									
<b>Characteristic bond resistance in uncracked concrete C20/25</b>									
Hammer-drilling with standard drill bit or hollow drill bit (dry or wet concrete)									
Temperature range	I: 24 °C / 40 °C	$\tau_{RK,ucr}$	[N/mm <sup>2</sup> ]	7,5	7,5	7,5	7,5	7	7
	II: 50 °C / 80 °C			6,5	6,5	6,5	6,5	6	6
Hammer-drilling with standard drill bit or hollow drill bit (flooded hole)									
Temperature range	I: 24 °C / 40 °C	$\tau_{RK,ucr}$	[N/mm <sup>2</sup> ]	---	---	7,5	7,5	7	7
	II: 50 °C / 80 °C			---	---	6,5	6,5	6	6
<b>Installation factors</b>									
Dry or wet concrete	$\gamma_{inst}$	[-]	1,0						
Flooded hole			---	1,2 <sup>1)</sup>					

<sup>1)</sup> Only with coaxial cartridges: 380ml, 400 ml, 410 ml

**Table C3.2:** Displacements for anchor rods

Anchor rod		M8	M10	M12	M16	M20	M24
<b>Displacement-Factors for tensile load<sup>1)</sup></b>							
<b>Uncracked concrete; Temperature range I, II</b>							
$\delta_{N0}$ -Factor	[mm/(N/mm <sup>2</sup> )]	0,09	0,09	0,10	0,10	0,10	0,10
$\delta_{N\infty}$ -Factor		0,10	0,10	0,12	0,12	0,12	0,13
<b>Displacement-Factors for shear load<sup>2)</sup></b>							
<b>Uncracked concrete; Temperature range I, II</b>							
$\delta_{V0}$ -Factor	[mm/kN]	0,11	0,11	0,10	0,10	0,09	0,09
$\delta_{V\infty}$ -Factor		0,12	0,12	0,11	0,11	0,10	0,10

<sup>1)</sup> Calculation of effective displacement:

$$\delta_{N0} = \delta_{N0}\text{-Factor} \cdot \tau_{Ed}$$

$$\delta_{N\infty} = \delta_{N\infty}\text{-Factor} \cdot \tau_{Ed}$$

( $\tau_{Ed}$ : Design value of the applied tensile stress)

<sup>2)</sup> Calculation of effective displacement:

$$\delta_{V0} = \delta_{V0}\text{-Factor} \cdot V_{Ed}$$

$$\delta_{V\infty} = \delta_{V\infty}\text{-Factor} \cdot V_{Ed}$$

( $V_{Ed}$ : Design value of the applied shear force)

fischer injection system FIS P Plus

**Performances**

Essential characteristics of tensile resistance for fischer anchor rod, standard threaded rods (uncracked concrete), Displacement for anchor rods