

ΔΗΛΩΣΗ ΕΠΙΔΟΣΕΩΝ

DoP 0341

για το σύστημα χημικών αγκυρίων fischer FIS EM Plus (για τοποθέτηση αναμονών οπλισμού)

EL

- Μοναδικός κωδικός ταυτοποίησης του τύπου του προϊόντος: DoP 0341
- Προβλεπόμενη(-ες) χρήση(-εις): Σύστημα για την μεταγενέστερη τοποθέτηση οπλισμού (αναμονές) με βελτιωμένη συνάφεια και συμπεριφορά σε θραύση ; δείτε το παράρτημα, ειδικά τα παραρτήματα B1-B9.
- Κατασκευαστής: fischerwerke GmbH & Co. KG, Otto-Hahn-Straße 15, 79211 Denzlingen, Γερμανία
- Εξουσιοδοτημένος αντιπρόσωπος: -
- Σύστημα/συστήματα AVCP (αξιολόγηση και επαλήθευση της σταθερότητας της επίδοσης): 1
- Ευρωπαϊκό έγγραφο αξιολόγησης: EAD 332402-00-0601-v02, Edition 10/2022
Ευρωπαϊκή τεχνική αξιολόγηση: ETA-22/0001; 2023-07-31
Οργανισμός τεχνικής αξιολόγησης: DIBt- Deutsches Institut für Bautechnik
Κοινοποιημένος(-οι) οργανισμός(-οι): 2873 TU Darmstadt
- Δηλωθείσα(-ες) επίδοση(-εις):
Μηχανική αντίσταση και σταθερότητα (BWR1)
Χαρακτηριστική αντίσταση σε εφελκυστικό φορτίο (στατικό και σχεδόν στατικό):
Αντίσταση για συνδυασμένη αστοχία από εξόλκευση και αστοχία σκυροδέματος σε μη ρηγματωμένο σκυρόδεμα: Παραρτήματα C1-C3
Αντίσταση σε αστοχία από κώνο σκυροδέματος: Παραρτήματα C1
Ανθεκτικότητα: Παραρτήματα C1-C3
Αντίσταση σε αστοχία από πρόσφυση: Παραρτήματα C1
Επιρροή του ρηγματωμένου σκυροδέματος στην αντίσταση από συνδυασμένη αστοχία λόγω εξόλκευσης και σκυροδέματος: Παραρτήματα C2, C3
Χαρακτηριστική αντίσταση σε εφελκυστικό φορτίο (σεισμική καταπόνηση):
Αντίσταση συνάφειας σε κυκλική φόρτιση: Παραρτήματα C4
Επιρροή του αυξημένου βάθους ρωγμής στην αστοχία από εξόλκευση: Παραρτήματα C4
Αντίσταση εξόλκευσης σε μη ρηγματωμένο σκυρόδεμα σε κυκλική φόρτιση: Παραρτήματα C4
Ασφάλεια σε περίπτωση φωτιάς (BWR 2)
Αντίδραση σε φωτιά: Κατηγορίας (A1)
- Κατάλληλη τεχνική τεκμηρίωση και/ή ειδική τεχνική τεκμηρίωση: -

Η επίδοση του προϊόντος που ταυτοποιείται ανωτέρω είναι σύμφωνη με τη (τις) δηλωθείσα(-ες) επίδοση(-εις). Αυτή η δήλωση επιδόσεων εκδίδεται σύμφωνα με τον Κανονισμό (ΕΕ) Αρ. 305/2011 με αποκλειστική ευθύνη του κατασκευαστή που προσδιορίζεται παραπάνω.

Υπογραφή για λογαριασμό και εξ ονόματος του κατασκευαστή από:



Dr.-Ing. Oliver Geibig, Γενικός Διευθυντής Επιχειρηματικών Μονάδων & Μηχανικός
Tumlingen, 2023-08-07



Jürgen Grün, Γενικός Διευθυντής Χημικών & Ποιότητας

Αυτή η Δήλωση Επιδόσεων μεταφράστηκε σε διάφορες γλώσσες. Σε περίπτωση που υπάρχει αμφιβολία για τη μετάφραση, υπερισχύει πάντα η αγγλική έκδοση.

Το παράρτημα περιλαμβάνει προαιρετικές και συμπληρωματικές πληροφορίες στα αγγλικά, που ξεπερνούν τις (οριζόμενες σε άλλες γλώσσες) νόμιμες απαιτήσεις.

Translation guidance Essential Characteristics and Performance Parameters for Annexes

Οδηγίες Μετάφρασης των βασικών χαρακτηριστικών και απόδοσης για τα παραρτήματα

Mechanical resistance and stability (BWR 1)		
Μηχανική αντίσταση και σταθερότητα (BWR1)		
Characteristic resistance to tension load (static and quasi-static loading):		
Χαρακτηριστική αντίσταση σε εφελκυστικό φορτίο (στατικό και σχεδόν στατικό):		
1	Resistance to combined pull-out and concrete failure in uncracked concrete: Αντίσταση για συνδυασμένη αστοχία από εξόλκευση και αστοχία σκυροδέματος σε μη ρηγματωμένο σκυρόδεμα:	$\tau_{FRk,ucr,50}$ [N/mm ²], $\psi_{sus,50}^0$ [-]; $\tau_{FRk,ucr,100}$ [N/mm ²]; $\psi_{sus,100}^0$ [-]
2	Resistance to concrete cone failure: Αντίσταση σε αστοχία από κώνο σκυροδέματος:	$c_{cr,N}$ [mm], $k_{ucr,N}$ [-], $k_{cr,N}$ [-]
3	Robustness: Ανθεκτικότητα:	γ_{inst} [-]
4	Resistance to bond-splitting failure: Αντίσταση σε αστοχία από πρόσφυση:	A_k [-], sp1 [-], sp2 [-], sp3 [-], sp4 [-], lb1 [-]
5	Influence of cracked concrete on resistance to combined pull-out and concrete failure: Annexes Επιρροή του ρηγματωμένου σκυροδέματος στην αντίσταση από συνδυασμένη αστοχία λόγω εξόλκευσης και σκυροδέματος:	$\Omega_{cr,05}$ [-]
Characteristic resistance to tension load (seismic loading):		
Χαρακτηριστική αντίσταση σε εφελκυστικό φορτίο (σεισμική καταπόνηση):		
6	Resistance to bond-splitting failure under cyclic loading: Αντίσταση συνάφειας σε κυκλική φόρτιση:	$a_{eq,sp}$ [-]
7	Influence of increased crack width on resistance to pull-out failure: Επιρροή του αυξημένου βάθους ρωγμής στην αστοχία από εξόλκευση:	$\Omega_{cr,05}$ [-], $\Omega_{cr,08}$ [-]
8	Resistance to pull-out failure in uncracked concrete under cyclic loading: Αντίσταση εξόλκευσης σε μη ρηγματωμένο σκυρόδεμα σε κυκλική φόρτιση:	$a_{eq,p}$ [-]
Safety in case of fire (BWR 2)		
Ασφάλεια σε περίπτωση φωτιάς (BWR 2)		
9	Reaction to fire: Class (A1) Αντίδραση σε φωτιά:	-

Specific Part

1 Technical description of the product

The subject of this European technical assessment is the post-installed connection, by anchoring or overlap connection joint, of reinforcing bars (rebars) in existing structures made of normal weight concrete, using the fischer injection system FIS EM Plus in accordance with the regulations for reinforced concrete construction.

Reinforcing bars with a diameter ϕ from 8 to 40 mm according to Annex A and the injection mortar FIS EM Plus are used for the post-installed rebar connection. The rebar is placed into a drilled hole filled with injection mortar and is anchored via the bond between embedded reinforcing bar, injection mortar and concrete.

The product description is given in Annex A.

2 Specification of the intended use in accordance with the applicable European assessment Document

The performances given in Section 3 are only valid if the rebar connection is used in compliance with the specifications and conditions given in Annex B.

The verifications and assessment methods on which this European Technical Assessment is based lead to the assumption of a working life of the rebar connections of at least 50 and/or 100 years. The indications given on the working life cannot be interpreted as a guarantee given by the producer, but are to be regarded only as a means for choosing the right products in relation to the expected economically reasonable working life of the works.

3 Performance of the product and references to the methods used for its assessment

3.1 Mechanical resistance and stability (BWR 1)

Essential characteristic	Performance
Characteristic resistance to tension load (static and quasi-static loading)	See Annex C 1 to C 3
Characteristic resistance to tension load (seismic loading)	See Annex C 4

3.2 Safety in case of fire (BWR 2)

Essential characteristic	Performance
Reaction to fire	Class A1

4 Assessment and verification of constancy of performance (AVCP) system applied, with reference to its legal base

In accordance with European Assessment Document EAD No. 332402-00-0601-v02, the applicable European legal act is: [96/582/EC].

The system to be applied is: 1

Installation conditions and application examples reinforcing bars

Figure A1.1:

Column / wall to foundation / slab

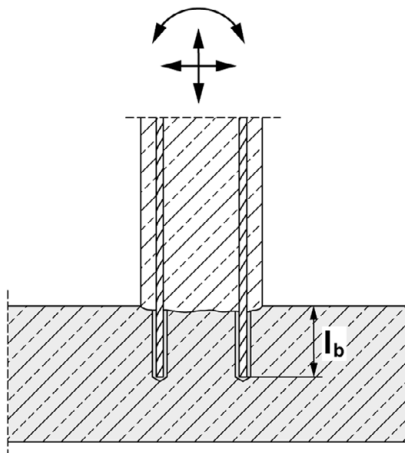
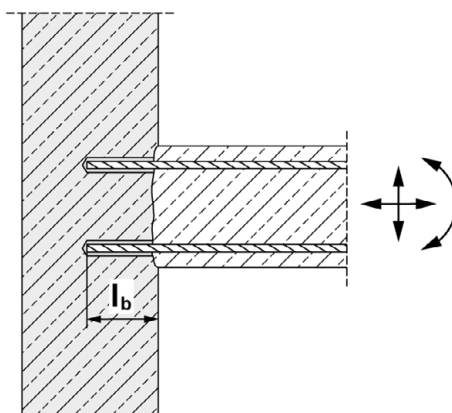

Figure A1.2:

Slab / beam to wall or beam to column



Figures not to scale

fischer injection system FIS EM Plus

Product description

Installation conditions and application examples reinforcing bars

Annex A 1

Appendix 3 / 18

Overview system components

Injection cartridge (shuttle cartridge) FIS EM Plus with sealing cap; Sizes: 390 ml, 585 ml, 1100 ml, 1500 ml

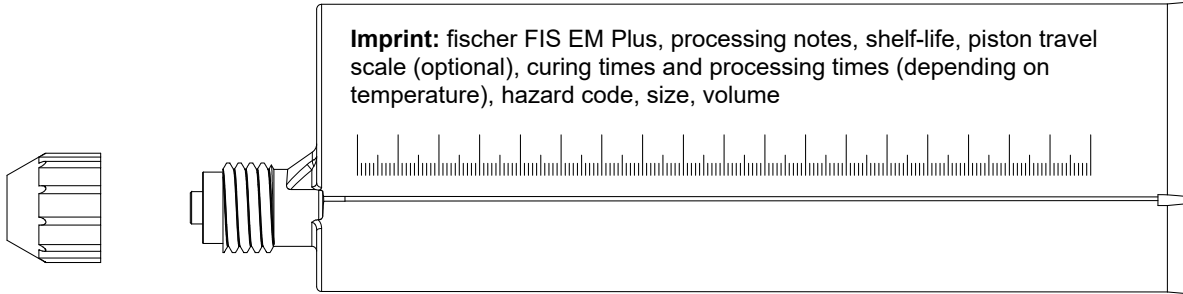

Static mixer FIS MR Plus for injection cartridges 390 ml

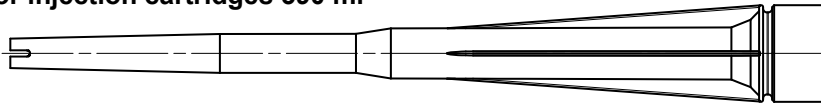

Static mixer FIS UMR for injection cartridges ≥ 585 ml



Injection adapter and extension tube $\varnothing 9$ for static mixer FIS MR Plus;
Injection adapter and extension tube $\varnothing 9$ or $\varnothing 15$ for static mixer FIS UMR

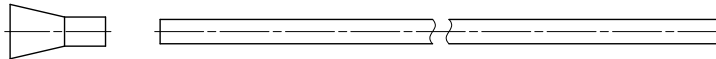

Reinforcing bar (rebar) Sizes: $\varnothing 8$, $\varnothing 10$, $\varnothing 12$, $\varnothing 14$, $\varnothing 16$, $\varnothing 20$, $\varnothing 22$, $\varnothing 24$, $\varnothing 25$, $\varnothing 26$, $\varnothing 28$, $\varnothing 30$, $\varnothing 32$, $\varnothing 34$, $\varnothing 36$, $\varnothing 40$

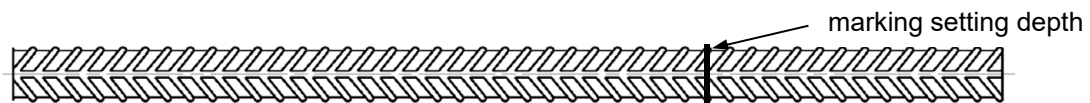

fischer cleaning brush



Compressed-air cleaning tool with fischer compressed-air nozzle

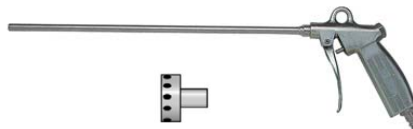

Figures not to scale

fischer injection system FIS EM Plus

Product description

Overview system components: injection mortar, static mixer, injection adapter, reinforcing bar, cleaning tools

Annex A 2

Appendix 4 / 18

Properties of reinforcing bars (rebar)

Figure A3.1:



- The minimum value of related rib area $f_{R,min}$ according to EN 1992-1-1:2004+AC:2010
- The maximum outer rebar diameter over the ribs shall be:
 - The nominal diameter of the bar with rib $\phi + 2 \cdot h_{rib}$ ($h_{rib} \leq 0,07 \cdot \phi$)
 - (ϕ : Nominal diameter of the bar; h_{rib} = rib height of the bar)

Table A3.1: Installation conditions for rebars

Nominal diameter of the bar		ϕ	8 ¹⁾	10 ¹⁾	12 ¹⁾	14	16	20	22	24			
Nominal drill hole diameter	d_0	[mm]	10	12	12	14	14	16	18	20	25	30	30
Drill hole depth	h_0		$h_0 \geq l_b$										
Effective embedment depth	$l_b = l_v$		acc. to static calculation										
Minimum thickness of concrete member	h_{min}		$l_b + 30$ (≥ 100)				$l_b + 2d_0$						

Nominal diameter of the bar		ϕ	25 ¹⁾	26	28	30	32	34	36	40	
Nominal drill hole diameter	d_0	[mm]	30	35	35	35	40	40	40	45	55
Drill hole depth	h_0		$h_0 \geq l_b$								
Effective embedment depth	$l_b = l_v$		acc. to static calculation								
Minimum thickness of concrete member	h_{min}		$l_b + 2d_0$								

¹⁾ Both drill hole diameters can be used

Table A3.2: Materials of rebars

Designation	Reinforcing bar (rebar)
Reinforcing bar EN 1992-1-1:2004+AC:2010, Annex C	Bars and de-coiled rods class B or C with f_{yk} and k according to NDP or NCI of EN 1992-1-1/NA $f_{uk} = f_{tk} = k \cdot f_{yk}$

fischer injection system FIS EM Plus



Product description
Properties and materials of reinforcing bars (rebar)

Annex A 3

Appendix 5 / 18

Specifications of intended use part 1

Table B1.1: Overview use and performance categories

Fastenings subject to		FIS EM Plus with ...	
		Reinforcing bar 	
Hammer drilling with standard drill bit 		all sizes	
Hammer drilling with hollow drill bit (fischer "FHD", Heller "Duster Expert"; Bosch „Speed Clean“; Hilti "TE-CD, TE-YD", DreBo „D-Plus“, DreBo „D-Max“) 		Nominal drill bit diameter (d_0) 12 mm to 35 mm	
Use category	11 dry or wet concrete	all sizes	
	12 water filled hole	all sizes (not permitted in combination with working life 100 years)	
Characteristic resistance under static and quasi-static loading	in uncracked concrete	all sizes	Tables: C1.1 C1.2 C2.1 C3.1
	in cracked concrete	all sizes	
Seismic performance		all sizes	Tables: C4.1
Installation direction	D3 (downward and horizontal and upwards (e.g. overhead))		
Installation temperature	$T_{i,min} = -5\text{ °C}$ to $T_{i,max} = +40\text{ °C}$ for the standard variation of temperature after installation		
Service temperature	Temperature range I	-40 °C to +60 °C	(max. short term temperature +60 °C; max. long term temperature +35 °C)
	Temperature range II	-40 °C to +72 °C	(max. short term temperature +72 °C; max. long term temperature +50 °C)

fischer injection system FIS EM Plus

Intended use
Specifications part 1

Annex B 1

Appendix 6 / 18

Specifications of intended use part 2

Anchorage subject to:

- Static and quasi-static loading: reinforcing bar (rebar) size 8 mm to 40 mm
- Seismic action: reinforcing bar (rebar) size 8 mm to 40 mm

Base materials:

- Compacted reinforced or unreinforced normal weight concrete without fibres according to EN 206:2013+A1:2016.
- Strength classes C20/25 to C50/60 according to EN 206:2013+A1:2016
- Maximum chloride content of 0,40 % (CL 0.40) related to the cement content according to EN 206:2013+A1:2016
- Non-carbonated concrete

Note: In case of a carbonated surface of the existing concrete structure, the carbonated layer shall be removed in the area of the post-installed rebar connection with a diameter of $\phi + 60$ mm prior to the installation of the new rebar. The depth of concrete to be removed shall correspond to at least the minimum concrete cover in accordance with EN 1992-1-1 :2004+AC:2010. The foregoing may be neglected if building components are new and not carbonated and if building components are in dry conditions.

Design:

- Fastenings are designed under the responsibility of an engineer experienced in fastenings and concrete work.
- Verifiable calculation notes and drawings are prepared taking account of the forces to be transmitted.
- Design under static and quasi-static loading and for seismic actions in accordance with EOTA Technical Report TR 069 June 2021.
- The actual position of the reinforcement in the existing structure shall be determined on the basis of the construction documentation and taken into account when designing.
- The shear force must be transferred via the rough joint; the subsequent reinforcement must not be applied for shear force transfer.

Installation:

- Rebar installation carried out by appropriately qualified personnel and under the supervision of the person responsible for technical matters of the site.
- Check the position of the existing rebars (if the position of existing rebars is not known, it shall be determined using a rebar detector suitable for this purpose as well as on the basis of the construction documentation and then marked on the building component for the overlap joint).
- Rebars in overhead installation have to be fixed in their position until the injection mortar is cured.

fischer injection system FIS EM Plus

Intended use
Specifications part 2

Annex B 2

Appendix 7 / 18

Table B3.1: Minimum concrete cover c_{min} ¹⁾ depending on the drilling method and the drilling tolerance²⁾

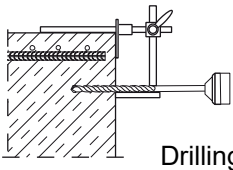
Drilling method	nominal diameter of reinforcing bar ϕ [mm]	Minimum concrete cover c_{min}		
		Without drilling aid [mm]	With drilling aid [mm]	
Hammer drilling with standard drill bit	< 25	$30 \text{ mm} + 0,06 l_b \geq 2 \phi$	$30 \text{ mm} + 0,02 l_b \geq 2 \phi$	
	≥ 25	$40 \text{ mm} + 0,06 l_b \geq 2 \phi$	$40 \text{ mm} + 0,02 l_b \geq 2 \phi$	
Hammer drilling with hollow drill bit (fischer "FHD", Heller "Duster Expert"; Bosch "Speed Clean"; Hilti "TE-CD, TE-YD")	< 25	$30 \text{ mm} + 0,06 l_b \geq 2 \phi$	$30 \text{ mm} + 0,02 l_b \geq 2 \phi$	
	≥ 25	$40 \text{ mm} + 0,06 l_b \geq 2 \phi$	$40 \text{ mm} + 0,02 l_b \geq 2 \phi$	

¹⁾ Note: The minimum concrete cover as specified in EN 1992-1-1:2004+AC:2010 must be observed.

²⁾ Minimum clear spacing is $a = \max(40 \text{ mm}; 4 \cdot \phi)$

Table B3.2: Dispensers and cartridge sizes corresponding to maximum embedment depth $l_{b,max}$

reinforcing bars (rebar)	Manual dispenser	Pneumatic or cordless dispenser (small)	Pneumatic or cordless dispenser (large)
	Cartridge size 390 ml, 585 ml	Cartridge size 390 ml, 585 ml	Cartridge size 1500 ml
ϕ [mm]	$l_{b,max}$ [mm]	$l_{b,max}$ [mm]	$l_{b,max}$ [mm]
8	1000	1000	1800
10		1200	
12			
14			
16			
20	700	1300	
22 / 24 / 25		1000	2000
26 / 28	500		
30 / 32 / 34	no performance assessed	500	
36 / 40			

Figures not to scale

fischer injection system FIS EM Plus

Intended use

Minimum concrete cover;
dispenser and cartridge sizes corresponding to maximum embedment depth

Annex B 3

Appendix 8 / 18

Table B4.1: Conditions for use static mixer without an extension tube

Nominal drill hole diameter d_0	[mm]	10	12	14	16	18	20	24	25	28	30	35	40
		Drill hole depth h_0 by FIS MR Plus using		≤ 90		≤ 120	≤ 140	≤ 150	≤ 160	≤ 190	≤ 210		
FIS UMR		-	-	≤ 90	≤ 160	≤ 180	≤ 190	≤ 220		≤ 250			

Table B4.2: Working times t_{work} and curing times t_{cure}

Temperature at anchoring base [°C]	Maximum processing time ¹⁾ t_{work}	Minimum curing time ²⁾ t_{cure}
-5 to 0	240 min ³⁾	200 h
>0 to 5	150 min ³⁾	90 h
>5 to 10	120 min ³⁾	40 h
>10 to 20	30 min	18 h
>20 to 30	14 min	10 h
>30 to 40	7 min ⁴⁾	5 h

¹⁾ Maximum time from the beginning of the injection to the setting and the final positioning of the rebar

²⁾ For wet concrete the curing time must be doubled

³⁾ If the temperature in the concrete falls below 10 °C the cartridge must be warmed up to +15 °C.

⁴⁾ If the temperature in the concrete exceeds 30 °C the cartridge must be cooled down to +15 °C up to 20 °C

Table B4.3: Installation tools for drilling and cleaning the bore hole and injection of the mortar

reinforcing bars (rebar) ϕ [mm]	Drilling and cleaning				Injection	
	Nominal drill bit diameter d_0 [mm]	Diameter of cutting edge d_{cut} [mm]	Steel brush diameter d_b [mm]	Diameter of cleaning nozzle ³⁾ [mm]	Diameter of extension tube [mm]	Injection adapter [colour]
8 ¹⁾	10 ²⁾	$\leq 10,50$	11	---	9	---
	12	$\leq 12,50$	14			nature
10 ¹⁾	12	$\leq 12,50$	14	11		blue
	14	$\leq 14,50$	16			red
12 ¹⁾	14	$\leq 14,50$	16	15	yellow	
	16	$\leq 16,50$	20		green	
14	18	$\leq 18,50$	20	19	black	
16	20	$\leq 20,55$	25		9 or 15	grey
20	25	$\leq 25,55$	27	grey		
22 / 24	30	$\leq 30,55$	32	28		brown
	30	$\leq 30,55$	32			brown
25 ¹⁾	35	$\leq 35,70$	37	38	red	
	36	$\leq 35,70$	37		yellow	
26 / 28	35	$\leq 35,70$	37	38	nature	
30 / 32 / 34	40 ²⁾	$\leq 40,70$	42			
36	45 ²⁾	$\leq 45,70$	47			
40	55 ²⁾	$\leq 55,70$	58			

¹⁾ Both drill bit diameters can be used

²⁾ Only hammer drilling with standard drill bit

³⁾ Cleaning nozzle and extension is only necessary if bore hole depth is greater than the length of compressed-air cleaning tool

fischer injection system FIS EM Plus

Intended use

Conditions for use static mixer without an extension tube; Working times and curing times; Installation tools for drilling and cleaning the bore hole and injection of the mortar

Annex B 4

Appendix 9 / 18

Safety regulations





Review the Safety Data Sheet (SDS) before use for proper and safe handling!
Wear well-fitting protective goggles and protective gloves when working with mortar FIS EM Plus.
Important: Observe the instructions for use provided with each cartridge.

Installation instruction part 1

Hole drilling

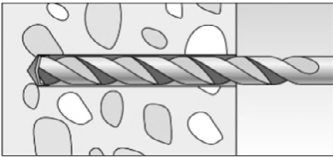
Note: Before drilling, remove carbonated concrete; clean contact areas (see Annex B 2)
In case of aborted drill holes the drill hole shall be filled with mortar.

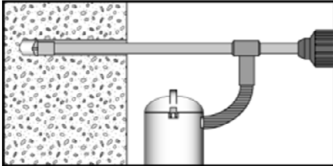
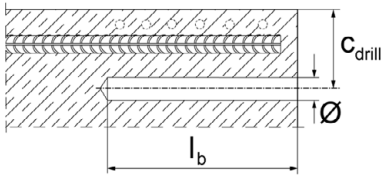
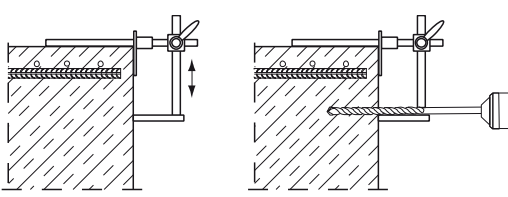
1a	<p>Hammer drilling with standard drill bit</p> 	<p>Drill the hole to the required embedment depth using a hammer drill with carbide drill bit set in rotation hammer mode. Nominal drill hole diameter d_0 (see table B4.3) and drill hole depth h_0 (see table A3.1).</p>
1b	<p>Hammer drilling with hollow drill bit</p> 	<p>Check a suitable hollow drill (see table B1.1) for correct operation of the dust extraction.</p>
		<p>Drill the hole to the required embedment depth using a hammer drill with hollow drill bit in rotation hammer mode. Dust extraction conditions see drill hole cleaning Annex B 6. Nominal drill hole diameter d_0 (see table B4.3) and drill hole depth h_0 (see table A3.1).</p>
		<p>Measure and control concrete cover c ($C_{drill} = c + \varnothing / 2$) Drill parallel to surface edge and to existing rebar. Where applicable use fischer drilling aid.</p>
2		<p>For holes $l_b > 20$ cm use drilling aid. Three different options can be considered: A) fischer drilling aid B) Slat or spirit level C) Visual check</p> <p>Minimum concrete cover c_{min} see table B3.1.</p>

fischer injection system FIS EM Plus

Intended use





Safety regulations; Installation instruction part 1, hole drilling

Annex B 5

Appendix 10 / 18

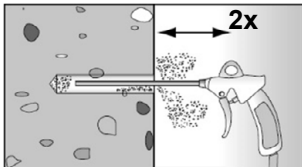
Installation instruction part 2

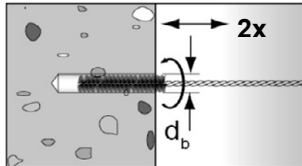
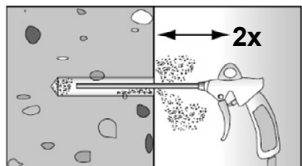
Drill hole cleaning (hammer drilling with standard drill bit)

		<p>Cleaning the drill hole. Blow out the drill hole twice, with oil free compressed air ($p \geq 6$ bar). If the drill hole depth is greater than the length of the compressed-air cleaning tool, an extension and appropriate fischer cleaning nozzle must be used. Corresponding diameters see table B4.3.</p>	
3a		<p>Brush the drill hole twice. For drill hole diameter ≥ 30 mm use a power drill. For deep holes use an extension. Corresponding brushes see table B4.3.</p>	
		<p>Cleaning the drill hole: Blow out the drill hole twice, with oil free compressed air ($p \geq 6$ bar). If the drill hole depth is greater than the length of the compressed-air cleaning tool, an extension and appropriate fischer cleaning nozzle must be used. Corresponding diameters see table B4.3.</p>	

Go to step 4

Drill hole cleaning (hammer drilling with hollow drill bit)

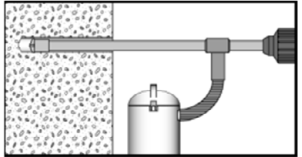
3b		<p>Use a suitable dust extraction system, e. g. fischer FVC 35 M or a comparable dust extraction system with equivalent performance data.</p> <p>Drill the hole with hollow drill bit. The dust extraction system has to extract the drill dust nonstop during the drilling process and must be adjusted to maximum power. Check the hollow drill for correct operation of the dust extraction. No further cleaning steps necessary.</p>
----	---	--

Go to step 4

fischer injection system FIS EM Plus



Intended use
Installation instruction part 2, drill hole cleaning

Annex B 6

Appendix 11 / 18

Installation instruction part 3

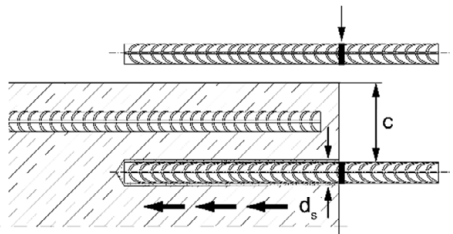
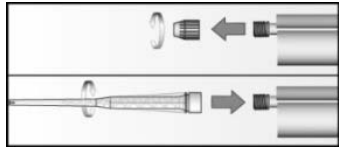
Reinforcing bars (rebar) and cartridge preparation

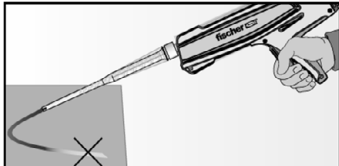
4		<p>Before use, make asure that the rebar is dry and free of oil or other residue. Mark the embedment depth l_b (e.g. with tape) Insert rebar in borehole, to verify drill hole depth and setting depth l_b.</p>
5		<p>Twist off the sealing cap Twist on the static mixer (the spiral in the static mixer must be clearly visible).</p>
6		<p>Place the cartridge into a suitable dispenser.</p>
7		<p>Press out approximately 10 cm of mortar until the resin is permanently grey in colour. Mortar which is not grey in colour will not cure and must be disposed.</p>

Go to step 8

fischer injection system FIS EM Plus

Intended use

Installation instruction part 3,
 reinforcing bars (rebar) and cartridge preparation

Annex B 7

Appendix 12 / 18

Installation instruction part 4; Installation with FIS EM Plus

Injection of the mortar without extension tube

8a

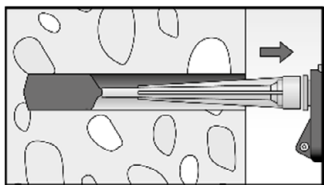

Inject the mortar from the back of the hole towards the front and slowly withdraw the static mixer step by step with each trigger pull. Avoid bubbles.

Fill holes approximately 2/3 (for $h_0 = l_b$) full, to ensure that the annular gap between the rebar and the concrete will be completely filled with adhesive over the entire embedment length. For $h_0 > l_b$ more mortar is needed.

The conditions for mortar injection without extension tube can be found in **table B4.1**

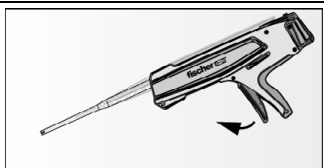

After injecting, release the dispenser. This will prevent further mortar discharge from the static mixer.

Injection of the mortar with extension tube

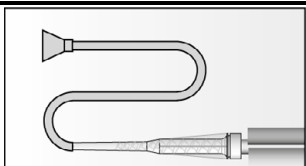

Assemble mixing nozzle FIS MR Plus or FIS UMR, extension tube and appropriate injection adapter (see **table B4.3**).

Mortar level mark

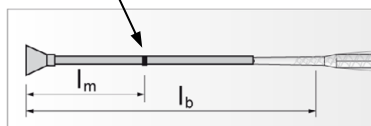

Mark the required mortar level l_m and embedment depth l_b with tape or marker on the injection extension tube.

a) Estimation:

$$l_m = \frac{1}{3} \cdot l_b \text{ [mm]}$$

b) Precise equation for optimum mortar volume:

$$l_m = l_b \cdot \left(1,2 \cdot \frac{d_s^2}{d_0^2} - 0,2 \right) \text{ [mm]}$$

8b

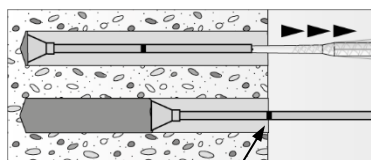

Mortar level mark

Insert injection adapter to back of the hole. Begin injection allowing the pressure of the injected adhesive mortar to push the injection adapter towards the front of the hole. Do not actively pull out!

Fill holes approximately 2/3 (for $h_0 = l_b$) full, to ensure that the annular gap between the rebar and the concrete will be completely filled with adhesive over the embedment length. For $h_0 > l_b$ more mortar is needed. When using an injection adapter continue injection until the mortar level mark l_m becomes visible.

Maximum embedment depth, see **table B3.2**.

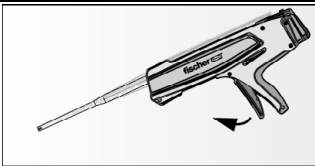

After injecting, release the dispenser. This will prevent further mortar discharge from the static mixer.

Go to step 9

fischer injection system FIS EM Plus

Intended use

Installation instruction part 4, mortar injection

Annex B 8

Appendix 13 / 18

Installation instruction part 5; Installation with FIS EM Plus

Insert rebar

9

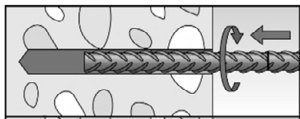

Insert the rebar slowly twisted into the borehole until the embedment mark is reached.

Recommendation:

Rotation back and forth of the reinforcement bar makes pushing easy

10

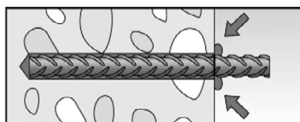

After installing the rebar the annular gap must be completely filled with mortar.

Proper installation

- Desired embedment depth is reached l_b :
embedment mark at concrete surface
- Excess mortar flows out of the borehole after the rebar have been fully inserted up to the embedment mark.

11

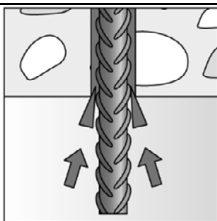

For overhead installation, support the rebar and secure it from falling till mortar started to harden, e.g. using wedges.

12



Observe the working time " t_{work} " (see **table B4.2**), which varies according to temperature of base material. Minor adjustments to the rebar position may be performed during the working time

Full load may be applied only after the curing time " t_{cure} " has elapsed (see **table B4.2**)

fischer injection system FIS EM Plus

Intended use

Installation instruction part 5, insert rebar

Annex B 9

Appendix 14 / 18

Table C1.1: Characteristic resistance under tension loading for reinforcing bars

Size		All sizes	
Characteristic resistance under tension loading			
Installation factor	γ_{inst}	[-]	See annex C 2 to C 3
Factors for the compressive strength of concrete > C20/25			
Increasing factor ψ_c for cracked or uncracked concrete $\tau_{Rk,C(X/Y)} = \psi_c \cdot \tau_{Rk (C20/25)}$	C25/30	[-]	1,02
	C30/37		1,04
	C35/45		1,06
	C40/50		1,07
	C45/55		1,08
	C50/60		1,09
Concrete cone failure			
Uncracked concrete	$k_{ucr,N}$	[-]	11,0
Cracked concrete	$k_{cr,N}$		7,7
Edge distance	$c_{cr,N}$	[mm]	$1,5 \cdot l_b$
Spacing	$s_{cr,N}$		$3 \cdot l_b$
Factors for sustained tension loading			
Factor	ψ_{sus}^0	[-]	- ¹⁾

¹⁾ No performance assessed

Table C1.2: Essential characteristics under tension loading for reinforcing bars in hammer drilled holes; uncracked or cracked concrete; working life 50 and 100 years

Nominal diameter of the bar		ϕ	8	10	12	14	16	18	20	22	24	25	26	28	30	32	34	36	40
Bond-splitting failure for working life of 50 and 100 years																			
Calculation diameter	d	[mm]	8	10	12	14	16	18	20	22	24	25	26	28	30	32	34	36	40
Hammer-drilling with standard drill bit or hollow drill bit for 50 and 100 years																			
Product basic factor	A_k	[-]	4,4																
Exponent for influence of concrete compressive strength	sp1		0,33																
Exponent for influence of rebar diameter ϕ	sp2		0,34																
Exponent for influence of concrete cover c_d	sp3		0,62																
Exponent for influence of side concrete cover (c_{max} / c_d)	sp4		0,33																
Exponent for influence of anchorage length l_b	lb1		0,68																

fischer injection system FIS EM Plus

Performances

Characteristic resistance under tension loading for reinforcing bars; uncracked or cracked concrete; working life 50 and 100 years

Annex C 1

Appendix 15 / 18

Table C2.1: Characteristic resistance under tension loading for reinforcing bars in hammer drilled holes; uncracked or cracked concrete; working life 50 years

Nominal diameter of the bar		ϕ	8	10	12	14	16	18	20	22	24	25	26	28	30	32	34	36	40		
Combined pullout and concrete cone failure																					
Calculation diameter		d	[mm]	8	10	12	14	16	18	20	22	24	25	26	28	30	32	34	36	40	
Uncracked concrete																					
Characteristic bond resistance in uncracked concrete C20/25																					
Hammer-drilling with standard drill bit or hollow drill bit (dry or wet concrete)																					
Tem- perature range	I: 35 °C / 60 °C		$\tau_{RK,ucr,50}$	[N/mm ²]	16	15	15	14	14	13	13	13	12	12	12	12	12	12	11	11	11
	II: 50 °C / 72 °C				15	14	14	13	13	12	12	12	12	11	11	11	11	11	11	11	10
Hammer-drilling with standard drill bit or hollow drill bit (water filled hole)																					
Tem- perature range	I: 35 °C / 60 °C		$\tau_{RK,ucr,50}$	[N/mm ²]	16	16	14	13	12	12	11	11	10	10	10	10	9	9	9	8	8
	II: 50 °C / 72 °C				15	14	13	12	12	11	11	10	10	9	9	9	9	9	8	8	8
Installation factors																					
Dry or wet concrete		γ_{inst}	[-]	1,0																	
Water filled hole				1,4																	
Influence of cracked concrete on combined pullout and concrete cone failure for working life of 50 years																					
Hammer-drilling with standard drill bit or hollow drill bit																					
Factor for influence of cracked concrete		$\Omega_{cr,03}$	[-]	0,91	0,91	0,91	0,91	0,91	0,91	0,91	0,92	0,92	0,92	0,92	0,92	0,92	0,92	0,93	0,93	0,93	0,93

fischer injection system FIS EM Plus

Performances

Characteristic resistance under tension loading for reinforcing bars; uncracked or cracked concrete; working life 50 years

Annex C 2

Appendix 16 / 18

Table C3.1: Characteristic resistance under tension loading for reinforcing bars in hammer drilled holes; uncracked or cracked concrete; working life 100 years

Nominal diameter of the bar		ϕ	8	10	12	14	16	18	20	22	24	25	26	28	30	32	34	36	40			
Combined pullout and concrete cone failure																						
Calculation diameter		d	[mm]	8	10	12	14	16	18	20	22	24	25	26	28	30	32	34	36	40		
Uncracked concrete																						
Characteristic bond resistance in uncracked concrete C20/25 ¹⁾																						
Hammer-drilling with standard drill bit or hollow drill bit (dry or wet concrete)																						
Temperature range	I: 35 °C / 60 °C		$\tau_{Rk,ucr,50}$	[N/mm ²]	16	15	15	14	14	13	13	13	12	12	12	12	12	12	11	11	11	
	II: 50 °C / 72 °C				15	14	14	13	13	12	12	12	12	12	11	11	11	11	11	11	10	10
Installation factors																						
Dry or wet concrete		γ_{inst}	[-]	1,0																		
Temperature range	I: 35 °C / 60 °C		$\alpha_{100\text{ years}}$	[-]	0,55	0,75	0,60	0,75	0,60	0,75	0,65	0,75	0,65	0,75	0,65	0,75	0,65	0,75	0,65	0,75	0,65	0,75
	II: 50 °C / 72 °C				0,60	0,75	0,60	0,75	0,65	0,75	0,65	0,75	0,65	0,75	0,65	0,75	0,65	0,75	0,65	0,75	0,65	0,75
Influence of cracked concrete on combined pullout and concrete cone failure for working life of 100 years																						
Hammer-drilling with standard drill bit or hollow drill bit (dry or wet concrete)																						
Factor for influence of cracked concrete		$\Omega_{cr,03}$	[-]	0,91	0,91	0,91	0,91	0,91	0,91	0,91	0,92	0,92	0,92	0,92	0,92	0,92	0,92	0,93	0,93	0,93	0,93	

1) Calculation of characteristic bond resistance in uncracked concrete $\tau_{Rk,100, ucr}$:

$$\tau_{Rk,100, ucr} = \alpha_{100\text{ years}} \cdot \tau_{Rk,ucr,50}$$

fischer injection system FIS EM Plus

Performances

Characteristic resistance under tension loading for reinforcing bars; uncracked or cracked concrete; working life 100 years

Annex C 3

Appendix 17 / 18

Table C4.1: Characteristic resistance under tension loading for reinforcing bars (rebars) in concrete under seismic action; working life of 50 and 100 years

Nominal diameter of the bar		ϕ	8	10	12	14	16	18	20	22	24	25	26	28	30	32	34	36	40	
Resistance to pull-out failure in uncracked concrete under cyclic loading for working life of 50 and 100 years																				
Hammer-drilling with standard drill bit or hollow drill bit (dry or wet concrete)																				
Reduction factor for pull-out Resistance under seismic action	$\alpha_{eq,p}$	[N/mm ²]	0,76												1,0					
Influence of increased crack width on resistance to pull-out failure for working life of 50 and 100 years																				
Hammer-drilling with standard drill bit or hollow drill bit (dry or wet concrete)																				
Factor for influence of cracked concrete	$\Omega_{cr,05}^{1)}$	[-]	0,86	0,86	0,86	0,86	0,86	0,86	0,86	0,86	0,86	0,86	0,86	0,86	0,86	0,87	0,87	0,87	0,87	
	$\Omega_{cr,08}^{1)}$		0,76	0,76	0,76	0,76	0,76	0,76	0,76	0,76	0,76	0,76	0,76	0,76	0,76	0,76	0,76	0,73	0,70	0,63
Resistance to bond-splitting failure under cyclic loading for working life of 50 and 100 years																				
Hammer-drilling with standard drill bit or hollow drill bit (dry or wet concrete)																				
Reduction factor for bond-splitting resistance under seismic action	$\alpha_{eq,sp}$	[-]	0,94																	

¹⁾ Assumed crack width in accordance with EOTA Technical Report TR 069 June 2021; Section 3.6.