

## ΔΗΛΩΣΗ ΕΠΙΔΟΣΕΩΝ

### DoP 0340

για το σύστημα έκχυσης fischer FIS EB II (χημικό αγκύριο για χρήση σε σκυρόδεμα)

EL

- |  |  |
|--|--|
| 1. <u>Μοναδικός κωδικός ταυτοποίησης του τύπου του προϊόντος:</u>  | <b>DoP 0340</b>  |
| 2. <u>Προβλεπόμενη(-ες) χρήση(-εις):</u>   | <b>Μεταγενέστερη αγκύρωση σε ρηγματωμένο ή μη ρηγματωμένο σκυρόδεμα, δείτε το παράρτημα, ειδικά τα παραρτήματα B1 - B11.</b>             |
| 3. <u>Κατασκευαστής:</u>   | <b>fischerwerke GmbH &amp; Co. KG, Klaus-Fischer-Str. 1, 72178 Waldachtal, Γερμανία</b>  |
| 4. <u>Εξουσιοδοτημένος αντιπρόσωπος:</u>   | -  |
| 5. <u>Σύστημα/συστήματα AVCP (αξιολόγηση και επαλήθευση της σταθερότητας της επίδοσης):</u>  | 1  |
| 6. <u>Ευρωπαϊκό έγγραφο αξιολόγησης:</u><br>Ευρωπαϊκή τεχνική αξιολόγηση:<br>Οργανισμός τεχνικής αξιολόγησης:<br>Κοινοποιημένος(-οι) οργανισμός(-οι):  | <b>EAD 330499-02-0601, Edition 04/2023<br/>ETA-21/0469; 2023-07-25<br/>DIBt- Deutsches Institut für Bautechnik<br/>2873 TU Darmstadt</b> |
| 7. <u>Δηλωθείσα(-ες) επίδοση(-εις):</u><br><b><u>Μηχανική αντίσταση και σταθερότητα (BWR1)</u></b><br><b>Χαρακτηριστική αντίσταση σε εφελκυστικό φορτίο (στατικό και σχεδόν στατικό):</b><br>1) Αντίσταση σε αστοχία χάλυβα: δείτε το παράρτημα, ειδικά τα Παραρτήματα C1, C2<br>2) Αντίσταση για συνδυασμένη αστοχία από ολίσθηση και κώνο σκυροδέματος: δείτε το παράρτημα, ειδικά τα Παραρτήματα C4 - C6<br>3) Αντίσταση σε αστοχία από κώνο σκυροδέματος: δείτε το παράρτημα, ειδικά τα Παραρτήματα C3<br>4) Απόσταση από ακμή για αποφυγή θραύσης από φορτίο: δείτε το παράρτημα, ειδικά τα Παραρτήματα C3<br>5) Ανθεκτικότητα: δείτε το παράρτημα, ειδικά τα Παραρτήματα C3 - C6<br>6) Μέγιστη ροπή σύσφιξης: δείτε το παράρτημα, ειδικά τα Παραρτήματα B3, B5<br>7) Ελάχιστη απόσταση από ακμή και μεταξύ αγκυρίων, πάχους μέλους: δείτε το παράρτημα, ειδικά τα Παραρτήματα B3 - B7<br><b>Χαρακτηριστική αντίσταση σε διατμητικό φορτίο (στατικό και σχεδόν στατικό):</b><br>8) Αντίσταση σε αστοχία χάλυβα: δείτε το παράρτημα, ειδικά τα Παραρτήματα C1, C2<br>9) Αντίσταση σε ολίσθηση: δείτε το παράρτημα, ειδικά τα Παραρτήματα C3<br>10) Αντίσταση σε αστοχία ακμής σκυροδέματος: δείτε το παράρτημα, ειδικά τα Παραρτήματα C3<br><b>Μετατόπιση σε βραχείας διάρκειας και μακράς διάρκειας φόρτιση:</b><br>11) Μετατόπιση σε βραχείας διάρκειας και μακράς διάρκειας φόρτιση: δείτε το παράρτημα, ειδικά τα Παραρτήματα C7<br>12) Αντοχή σε οπλισμένο με χαλύβδινες ίνες σκυρόδεμα: NPD<br><b>Χαρακτηριστική αντίσταση και μετακινήσεις για τις σεισμικές κατηγορίες C1 και C2 (προαιρετικά):</b><br>13) Αντίσταση σε εφελκυσμό, κατηγορία C1: δείτε το παράρτημα, ειδικά τα Παραρτήματα C8 - C11<br>14) Αντίσταση σε εφελκυσμό, κατηγορία C2: δείτε το παράρτημα, ειδικά τα Παραρτήματα C8 - C10, C12, C13<br>15) Αντίσταση σε διάτμηση, κατηγορία C1: δείτε το παράρτημα, ειδικά τα Παραρτήματα C8 - C10<br>16) Αντίσταση σε διάτμηση, κατηγορία C2: δείτε το παράρτημα, ειδικά τα Παραρτήματα C8 - C10, C12, C13<br><b><u>Ασφάλεια σε περίπτωση φωτιάς (BWR 2)</u></b><br>17) Αντίδραση σε φωτιά: Κατηγορίας (A1)<br><b>Αντίσταση στη φωτιά:</b><br>18) Αντίσταση σε φωτιά για αστοχία χάλυβα (εφελκυστικό φορτίο): δείτε το παράρτημα, ειδικά τα Παραρτήματα C14, C15<br>19) Αντοχή δεσμού σε συνθήκες πυρκαγιάς: δείτε το παράρτημα, ειδικά τα Παραρτήματα C16<br>20) Αντίσταση σε φωτιά για αστοχία χάλυβα (διατμητικό φορτίο): δείτε το παράρτημα, ειδικά τα Παραρτήματα C14, C15<br><b><u>Υγιεινή, υγεία και περιβάλλον (BWR 3)</u></b><br>21) Περιεχόμενο, εκπομπή ή/και απελευθέρωση επικίνδυνων ουσιών: NPD |  |
| 8. <u>Κατάλληλη τεχνική τεκμηρίωση και/ή ειδική τεχνική τεκμηρίωση:</u>  | -  |

Η επίδοση του προϊόντος που ταυτοποιείται ανωτέρω είναι σύμφωνη με τη (τις) δηλωθείσα(-ες) επίδοση(-εις). Αυτή η δήλωση επιδόσεων εκδίδεται σύμφωνα με τον Κανονισμό (ΕΕ) Αρ. 305/2011 με αποκλειστική ευθύνη του κατασκευαστή που προσδιορίζεται παραπάνω.

Υπογραφή για λογαριασμό και εξ ονόματος του κατασκευαστή από:



Dr.-Ing. Oliver Geibig, Γενικός Διευθυντής Επιχειρηματικών Μονάδων & Μηχανικής  
Tumlingen, 2023-08-15

Jürgen Grün, Γενικός Διευθυντής Χημικών & Ποιότητας

Αυτή η Δήλωση Επιδόσεων μεταφράστηκε σε διάφορες γλώσσες. Σε περίπτωση που υπάρχει αμφιβολία για τη μετάφραση, υπερισχύει πάντα η αγγλική έκδοση.

Το παράρτημα περιλαμβάνει προαιρετικές και συμπληρωματικές πληροφορίες στα αγγλικά, που ξεπερνούν τις (οριζόμενες σε άλλες γλώσσες) νόμιμες απαιτήσεις.

Translation guidance Essential Characteristics and Performance Parameters for Annexes

**Οδηγίες Μετάφρασης των βασικών χαρακτηριστικών και απόδοσης για τα παραρτήματα**

Mechanical resistance and stability (BWR 1)		
<b>Μηχανική αντίσταση και σταθερότητα (BWR1)</b>		
Characteristic resistance to tension load (static and quasi-static loading):		
<b>Χαρακτηριστική αντίσταση σε εφελκυστικό φορτίο (στατικό και σχεδόν στατικό):</b>		
1	Resistance to steel failure: <b>Αντίσταση σε αστοχία χάλυβα:</b>	$N_{Rk,s}$ [kN]
2	Resistance to combined pull-out and concrete cone failure: <b>Αντίσταση για συνδυασμένη αστοχία από ολίσθηση και κώνο σκυροδέματος:</b>	$T_{Rk}$ and/or $T_{Rk,100}$ [N/mm <sup>2</sup> ], $\psi_c, \psi_{sus}, \psi_{sus,100}$ [-] (BF)
	Resistance to pull-out failure: <b>Αντίσταση σε αστοχία από εξόλκευση:</b>	$N_{Rk,p}$ and/or $N_{Rk,p,100}$ [kN], $\psi_c$ [-] (BEF)
3	Resistance to concrete cone failure: <b>Αντίσταση σε αστοχία από κώνο σκυροδέματος:</b>	$c_{cr,N}$ [mm], $k_{cr,N}$ , $k_{ucr,N}$ [-]
4	Edge distance to prevent splitting under load: <b>Απόσταση από ακμή για αποφυγή θραύσης από φορτίο:</b>	$c_{cr,sp}$ [mm]
5	Robustness: <b>Ανθεκτικότητα:</b>	$\gamma_{inst}$ [-]
6	Maximum installation torque: <b>Μέγιστη ροπή σύσφιξης:</b>	$\max T_{inst}$ [Nm] (BF)
	Installation torque: <b>ροπή σύσφιξης:</b>	$T_{inst}$ [Nm] (BEF)
7	Minimum edge distance, spacing and member thickness: <b>Ελάχιστη απόσταση από ακμή και μεταξύ αγκυρίων, πάχος μέλους:</b>	$c_{min}, s_{min}, h_{min}$ [mm]
Characteristic resistance to shear load (static and quasi-static loading):		
<b>Χαρακτηριστική αντίσταση σε διατμητικό φορτίο (στατικό και σχεδόν στατικό):</b>		
8	Resistance to steel failure: <b>Αντίσταση σε αστοχία χάλυβα:</b>	$V_{Rk,s}$ [kN], $M_{Rk,s}^0$ [Nm], $k_7$ [-]
9	Resistance to pry-out failure: <b>Αντίσταση σε ολίσθηση:</b>	$k_8$ [-]
10	Resistance to concrete edge failure: <b>Αντίσταση σε αστοχία ακμής σκυροδέματος:</b>	$d_{nom}, l_f$ [mm]
Displacements under short-term and long-term loading:		
<b>Μετατόπιση σε βραχείας διάρκειας και μακράς διάρκειας φόρτιση:</b>		
11	Displacements under short-term and long-term loading: <b>Μετατόπιση σε βραχείας διάρκειας και μακράς διάρκειας φόρτιση:</b>	$\delta_0, \delta_\infty$ [mm or mm/(N/mm <sup>2</sup> )]
12	Resistance in steel fibre reinforced concrete: <b>Αντοχή σε οπλισμένο με χαλύβδινες ίνες σκυρόδεμα:</b>	Description
Characteristic resistance and displacements for seismic performance categories C1 and C2:		
<b>Χαρακτηριστική αντίσταση και μετακινήσεις για τις σεισμικές κατηγορίες C1 και C2 (προαιρετικά):</b>		
13	Resistance to tension for seismic performance category C1 <b>Αντίσταση σε εφελκυσμό, κατηγορία C1:</b>	$N_{Rk,s,C1}$ [kN] (all) $T_{Rk,C1}$ [N/mm <sup>2</sup> ] (BF) $N_{Rk,p,C1}$ [kN] (BEF)
14	Resistance to tension for seismic performance category C2 <b>Αντίσταση σε εφελκυσμό, κατηγορία C2:</b>	$N_{Rk,s,C2}$ [kN] (all) $T_{Rk,C2}$ [N/mm <sup>2</sup> ] (BF) $N_{Rk,p,C2}$ [kN] (BEF) $\delta_{N,C2}$ [mm] (all)
15	Resistance to tension for seismic performance category C1 <b>Αντίσταση σε διάτμηση, κατηγορία C1:</b>	$V_{Rk,s,C1}$ [kN] (all)
16	Resistance to tension for seismic performance category C2 <b>Αντίσταση σε διάτμηση, κατηγορία C2:</b>	$V_{Rk,s,C2}$ [kN] (all) $\delta_{V,C2}$ [mm] (all)
Hygiene, health and the environment (BWR 3)		
<b>Υγιεινή, υγεία και περιβάλλον (BWR 3)</b>		
17	Reaction to fire <b>Αντίδραση σε φωτιά:</b>	Class Κατηγορίας (A1)
Resistance to fire		
<b>Αντίσταση στη φωτιά:</b>		
18	Fire resistance to steel failure (tension load): <b>Αντίσταση σε φωτιά για αστοχία χάλυβα (εφελκυστικό φορτίο):</b>	$N_{Rk,s,fi}$ [kN]
19	Bond resistance under fire conditions: <b>Αντοχή δεσμού σε συνθήκες πυρκαγιάς:</b>	$k_{fi,p}$ (θ) [-], $T_{Rk,fi}$ (θ) [N/mm <sup>2</sup> ] (BF)
20	Fire resistance to steel failure under shear loading: <b>Αντίσταση σε φωτιά για αστοχία χάλυβα (διατμητικό φορτίο):</b>	$V_{Rk,s,fi}$ [kN], $M_{Rk,s,fi}^0$ [Nm]
Hygiene, health and the environment (BWR 3)		
<b>Υγιεινή, υγεία και περιβάλλον (BWR 3)</b>		
21	Content, emission and/or release of dangerous substances: <b>Περιεχόμενο, εκπομπή ή/και απελευθέρωση επικίνδυνων ουσιών:</b>	Description/Level

## Specific Part

### 1 Technical description of the product

The fischer injection system FIS EB II is a bonded fastener consisting of a cartridge with injection mortar fischer FIS EB II and a steel element according to Annex A 4.

The steel element is placed into a drilled hole filled with injection mortar and is anchored via the bond between metal part, injection mortar and concrete.

The product description is given in Annex A.

### 2 Specification of the intended use in accordance with the applicable European Assessment Document

The performances given in Section 3 are only valid if the anchor is used in compliance with the specifications and conditions given in Annex B.

The verifications and assessment methods on which this European Technical Assessment is based lead to the assumption of a working life of the anchor of at least 50 years. The indications given on the working life cannot be interpreted as a guarantee given by the producer, but are to be regarded only as a means for choosing the right products in relation to the expected economically reasonable working life of the works.

### 3 Performance of the product and references to the methods used for its assessment

#### 3.1 Mechanical resistance and stability (BWR 1)

Essential characteristic	Performance
Characteristic resistance to tension load (static and quasi-static loading)	See Annex C 1 to C 6, B 3 to B7
Characteristic resistance to shear load (static and quasi-static loading)	See Annex C 1 to C 3
Displacements under short-term and long-term loading	See Annex C 7
Characteristic resistance and displacements for seismic performance categories C1 and C2	See Annex C 8 to C 13

#### 3.2 Safety in case of fire (BWR 2)

Essential characteristic	Performance
Reaction to fire	Class A1
Resistance to fire	See Annex C 14 to C 16

#### 3.3 Hygiene, health and the environment (BWR 3)

Essential characteristic	Performance
Content, emission and/or release of dangerous substances	No performance assessed

**4 Assessment and verification of constancy of performance (AVCP) system applied, with reference to its legal base**

In accordance with EAD 330499-02-0601 the applicable European legal act is: [96/582/EC].

The system to be applied is: 1

# Installation conditions part 1

fischer anchor rod FIS A / RG (Anchor rod) and commercial standard threaded rods (Threaded rod)

## Pre-positioned installation

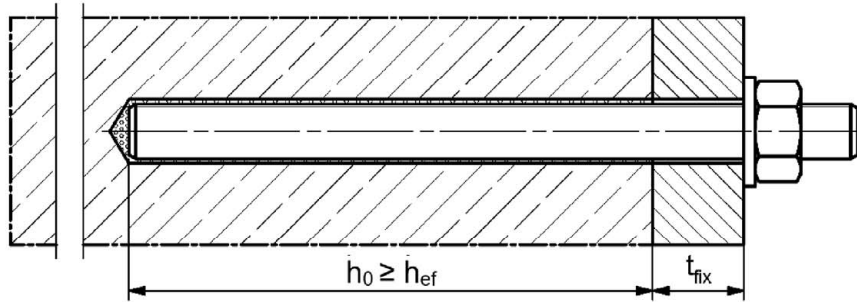

## Push through installation (annular gap filled with mortar)

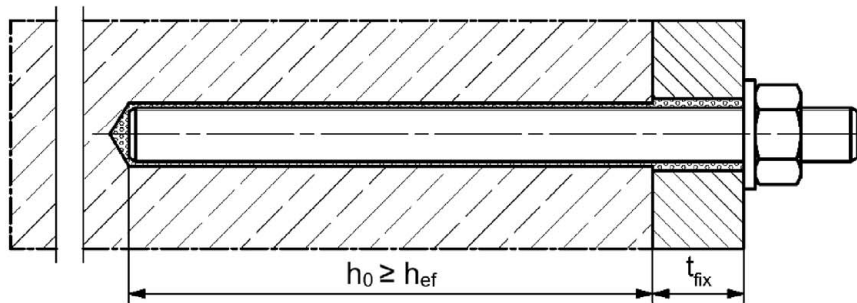

## Pre-positioned or push through installation with subsequently injected filling disk (annular gap filled with mortar)

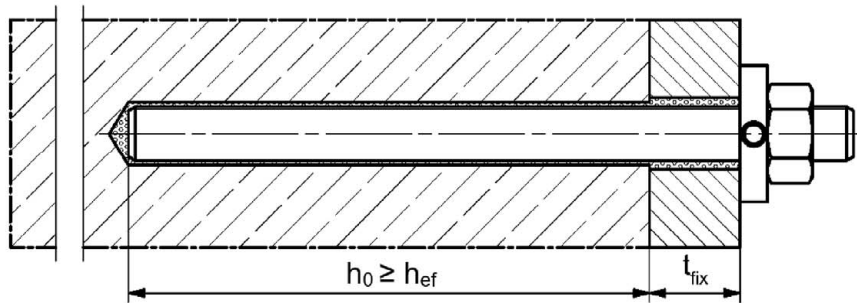

Figures not to scale

$h_0$  = drill hole depth

$h_{ef}$  = effective embedment depth

$t_{fix}$  = thickness of fixture

fischer injection system FIS EB II

**Product description**  
Installation conditions part 1

**Annex A 1**

Appendix 3 / 34

## Installation conditions part 2

### Reinforcing bar (Rebar)

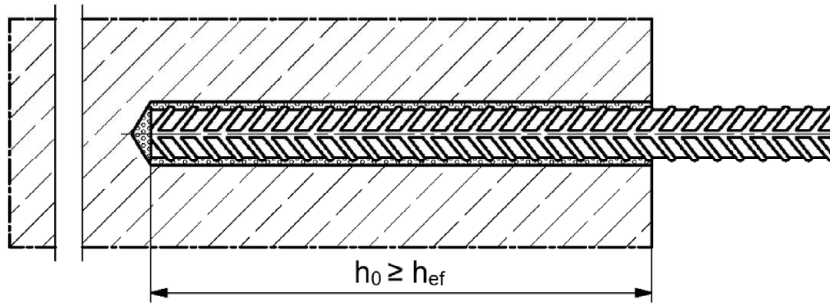

### fischer rebar anchor FRA (fischer FRA)

#### Pre-positioned installation

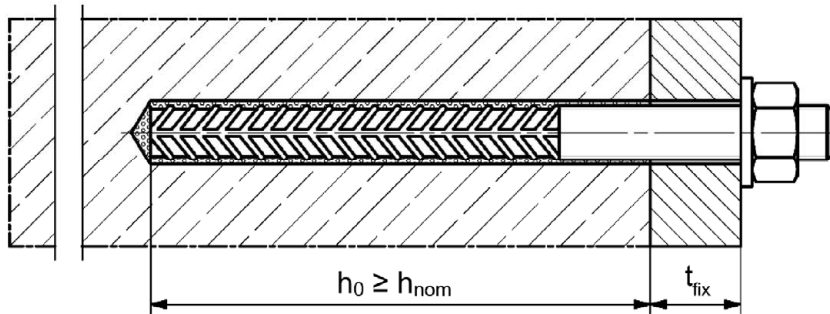

#### Push through installation (annular gap filled with mortar)

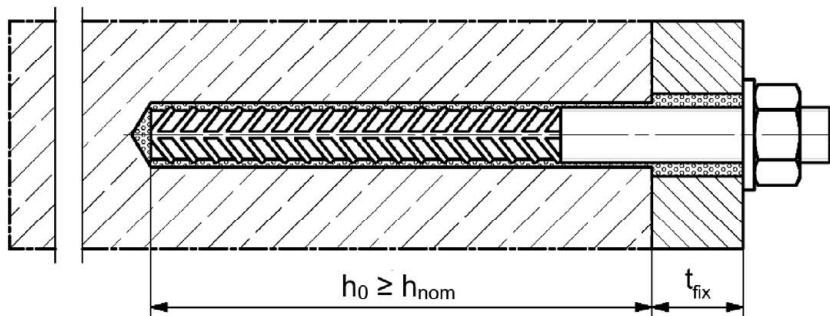

Figures not to scale

$h_0$  = drill hole depth

$h_{ef}$  = effective embedment depth

$t_{fix}$  = thickness of fixture

$h_{nom}$  = overall fastener embedment depth in the concrete

fischer injection system FIS EB II

**Product description**  
Installation conditions part 2

**Annex A 2**

Appendix 4 / 34

# Overview system components part 1

**Injection cartridge (shuttle cartridge) with sealing cap; Size: 390 ml, 585 ml, 1100 ml, 1500 ml**

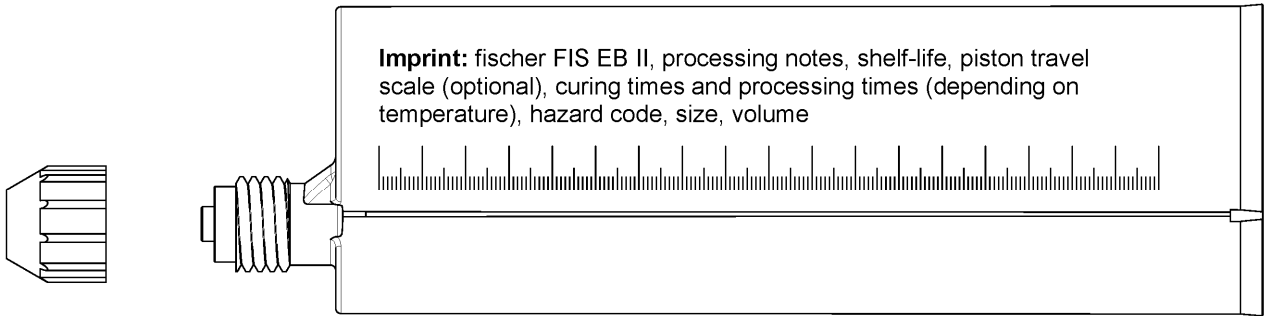

**Static mixer FIS MR Plus for Injection cartridge 390 ml**

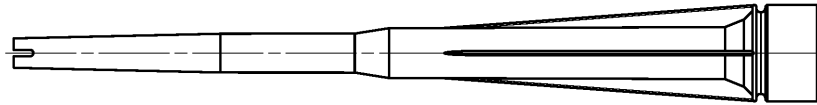

**Static mixer FIS UMR Injection cartridges  $\geq 585$  ml**

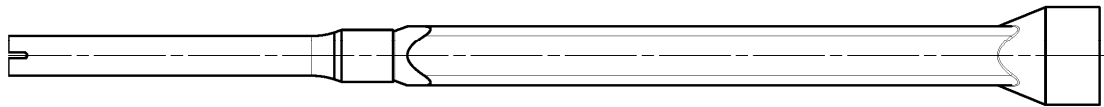

**Injection adapter and extension tube  $\varnothing 9$  for static mixer FIS MR Plus;  
Injection adapter and extension tube  $\varnothing 9$  or  $\varnothing 15$  for static mixer FIS UMR**

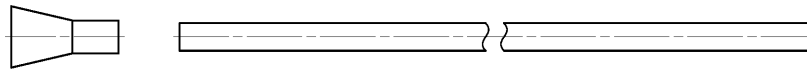

**Cleaning brush BS**



**Blow-out pump AB G**



**Compressed-air cleaning tool ABP**



Figures not to scale

fischer injection system FIS EB II

## Product description

Overview system components part 1; cartridges / static mixer / accessories

**Annex A 3**

Appendix 5 / 34

## Overview system components part 2

### Anchor rod

Size: M8, M10, M12, M16, M20, M24, M27, M30

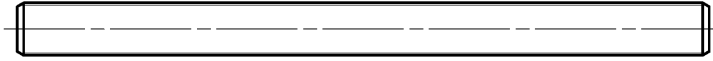

### Washer / hexagon nut

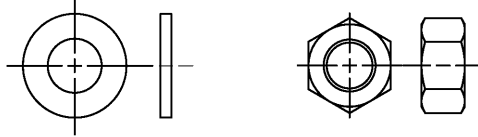

### fischer filling disk with injection adapter

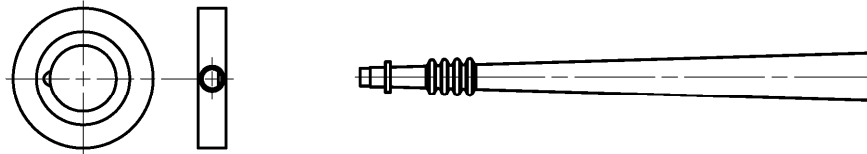

### Rebar

Nominal diameter:  $\phi 8$ ,  $\phi 10$ ,  $\phi 12$ ,  $\phi 14$ ,  $\phi 16$ ,  $\phi 20$ ,  $\phi 25$ ,  $\phi 26$ ,  $\phi 28$ ,  $\phi 30$ ,  $\phi 32$

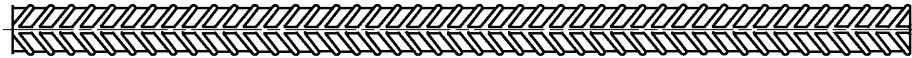

### fischer FRA, FRA HCR

Size: M12, M16, M20, M24



Figures not to scale

fischer injection system FIS EB II

### Product description

Overview system components part 2; steel components, injection adapter

**Annex A 4**

Appendix 6 / 34



**Table A5.1: Materials**

Part	Designation	Material		
1	Injection cartridge	Mortar, hardener, filler		
	Steel grade	Steel zinc plated	Stainless steel R acc. to EN 10088-1:2014 Corrosion resistance class CRC III acc. to EN 1993-1-4:2006+A1:2015	High corrosion resistant steel HCR acc. to EN 10088-1:2014 Corrosion resistance class CRC V acc. to EN 1993-1-4:2006+A1:2015
2	Anchor rod or Threaded rod	Property class 4.8, 5.8 or 8.8; EN ISO 898-1:2013 electroplated $\geq 5 \mu\text{m}$ , DIN EN ISO 4042:2022 or hot dip galvanised $\geq 40 \mu\text{m}$ EN ISO 10684:2004+AC:2009 $f_{uk} \leq 1000 \text{ N/mm}^2$ fracture elongation $A_5 > 12 \%$	Property class 50, 70 or 80; EN ISO 3506-1:2020 1.4401; 1.4404; 1.4578; 1.4571; 1.4439; 1.4362; 1.4062, 1.4662, 1.4462; EN 10088-1:2014 $f_{uk} \leq 1000 \text{ N/mm}^2$ fracture elongation $A_5 > 12 \%$	Property class 50 or 80; EN ISO 3506-1:2020 or property class 70 1.4565; 1.4529; EN 10088-1:2014 $f_{uk} \leq 1000 \text{ N/mm}^2$ fracture elongation $A_5 > 12 \%$
		Fracture elongation $A_5 > 8 \%$ for applications without requirements for seismic performance category C2		
3	Washer ISO 7089:2000	electroplated $\geq 5 \mu\text{m}$ , EN ISO 4042:2022 or hot dip galvanised $\geq 40 \mu\text{m}$ EN ISO 10684:2004+AC:2009	1.4401; 1.4404; 1.4578; 1.4571; 1.4439; 1.4362; EN 10088-1:2014	1.4565; 1.4529; EN 10088-1:2014
4	Hexagon nut	Property class 5 or 8 acc. EN ISO 898-2:2012 electroplated $\geq 5 \mu\text{m}$ , EN ISO 4042:2022 or hot dip galvanised $\geq 40 \mu\text{m}$ EN ISO 10684:2004+AC:2009	Property class 50, 70 or 80 acc. EN ISO 3506-2:2020 1.4401; 1.4404; 1.4578; 1.4571; 1.4439; 1.4362; EN 10088-1:2014	Property class 50, 70 or 80 acc. EN ISO 3506-2:2020 1.4565; 1.4529 EN 10088-1:2014
5	fischer filling disk	electroplated $\geq 5 \mu\text{m}$ , EN ISO 4042:2022 or hot dip galvanised $\geq 40 \mu\text{m}$ EN ISO 10684:2004+AC:2009	1.4401; 1.4404; 1.4578; 1.4571; 1.4439; 1.4362; EN 10088-1:2014	1.4565; 1.4529; EN 10088-1:2014
6	Rebar EN 1992-1-1:2004 and AC:2010, Annex C	Bars and de-coiled rods, class B or C with $f_{yk}$ and $k$ according to NDP or NCI according to EN 1992-1-1/NA $f_{uk} = f_{tk} = k \cdot f_{yk} (A_5 > 12 \%)$		
		Fracture elongation $A_5 > 8 \%$ for applications without requirements for seismic performance category C2		
7	fischer FRA	Rebar part: Bars and de-coiled rods class B or C with $f_{yk}$ and $k$ according to NDP or NCI of EN 1992-1-1:2004+AC:2010 $f_{uk} = f_{tk} = k \cdot f_{yk} (A_5 > 12 \%)$ Threaded part: Property class 80 EN ISO 3506-1:2020	1.4401, 1.4404, 1.4571, 1.4578, 1.4439, 1.4362, 1.4062 acc. to EN 10088-1:2014 Corrosion resistance class CRC III acc. to EN 1993-1-4:2006+A1:2015 1.4565; 1.4529 acc. to EN 10088-1:2014 Corrosion resistance class CRC V acc. to EN 1993-1-4: 2006+A1:2015 $f_{uk} \leq 1000 \text{ N/mm}^2$ ; fracture elongation $A_5 > 12 \%$	
		Fracture elongation $A_5 > 8 \%$ for applications without requirements for seismic performance category C2		

fischer injection system FIS EB II





**Product description**  
Materials

**Annex A 5**

Appendix 7 / 34

# Specifications of intended use part 1

**Table B1.1:** Overview use and performance categories

Anchorages subject to		FIS EB II with ...					
		Anchor rod, Threaded rod 		Rebar 		fischer FRA 	
Hammer drilling with standard drill bit 		all sizes					
Static and quasi-static loading, in	uncracked concrete	all sizes	Tables: C1.1 C3.1 C4.1 C7.1	all sizes	Tables: C2.1 C3.1 C5.1 C7.2	all sizes	Tables: C2.2 C3.1 C6.1 C7.2
	cracked concrete						
Use category	I1 dry or wet concrete	all sizes					
	I2 water filled hole	all sizes					
Seismic performance category	C1	Tables: C8.1 C9.3 C10.1 C11.1	Tables: C9.1 C9.3 C10.1 C11.2	Tables: C9.2 C9.3 C10.1 C11.2			
	C2	Tables: C8.1 C10.1 C12.1	Tables: C9.1 C10.1 C13.1	Tables: C9.2 C10.1 C13.1			
Installation direction		D3 (downward and horizontal and upwards (e.g. overhead))					
Installation temperature		$T_{i,min} = +5\text{ °C}$ to $T_{i,max} = +40\text{ °C}$					
Resistance to fire		Tables: C14.1 Annex: C 16	Tables: C15.1 Annex: C 16	Tables: C15.1 Annex C 16			
Service temperature	Temperature range I	-40 °C to +43 °C	(max. short term temperature +43 °C; max. long term temperature +24 °C)				
	Temperature range II	-40 °C to +60 °C	(max. short term temperature +60 °C; max. long term temperature +43 °C)				
	Temperature range III	-40 °C to +72 °C	(max. short term temperature +72 °C; max. long term temperature +50 °C)				

<sup>1)</sup> No performance assessed

fischer injection system FIS EB II

**Intended use**  
Specifications part 1

**Annex B 1**

Appendix 8 / 34

## Specifications of intended use part 2

### Base materials:

- Compacted reinforced or unreinforced normal weight concrete without fibres of strength classes C20/25 to C50/60 according to EN 206:2013+A2:2021.

### Use conditions (Environmental conditions):

- Structures subject to dry internal conditions (zinc coated steel, stainless steel or high corrosion resistant steel).
- For all other conditions according to EN1993-1-4:2006+A1:2015 corresponding to corrosion resistance classes to Annex A 5 Table 5.1.

### Design:

- Fastenings are designed under the responsibility of an engineer experienced in fastenings and concrete work.
- Verifiable calculation notes and drawings are to be prepared taking account of the loads to be anchored. The position of the fastener is indicated on the design drawings (e. g. position of the fastener relative to reinforcement or to supports, etc.).
- Fastenings are designed in accordance with: EN 1992-4:2018 and TR 082 from June 2023.

### Installation:

- Fastener installation is to be carried out by appropriately qualified personnel and under the supervision of the person responsible for technical matters of the site.
- Fastening depth should be marked and adhered to installation.
- Overhead installation is allowed (necessary equipment see installation instruction).

fischer injection system FIS EB II

**Intended use**  
Specifications part 2

**Annex B 2**

Appendix 9 / 34

**Table B3.1: Installation parameters for Anchor rods**

Anchor rods		M8	M10	M12	M16	M20	M24	M27	M30	
Nominal drill hole diameter	$d_0$	10	12	14	18	24	28	30	35	
Drill hole depth	$h_0$	$h_0 \geq h_{ef}$								
Effective embedment depth	$h_{ef, min}$	60	60	70	80	90	96	108	120	
	$h_{ef, max}$	160	200	240	320	400	480	540	600	
Simplified spacing and edge distance <sup>1)</sup>	$s$ = $c$	40	45	55	65	85	105	120	140	
	[mm]									
Diameter of the clearance hole of the fixture	pre-positioned installation $d_f$	9	12	14	18	22	26	30	33	
	push through installation $d_f$	12	14	16	20	26	30	33	40	
Minimum thickness of concrete member	$h_{min}$	$h_{ef} + 30$ ( $\geq 100$ )			$h_{ef} + 2d_0$					
Maximum installation torque	$\max T_{inst}$	[Nm]	10	20	40	60	120	150	200	300

<sup>1)</sup> Detailed calculation according to Annex B 6 and B 7

**Anchor rod**

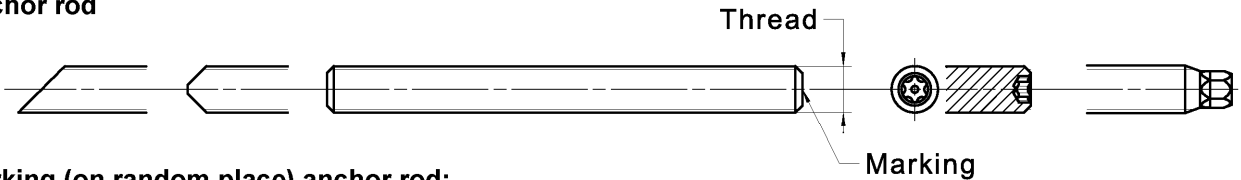

**Marking (on random place) anchor rod:**

Steel electroplated PC <sup>1)</sup> 8.8	• or +	Steel hot-dip PC <sup>1)</sup> 8.8	•
High corrosion resistant steel HCR PC <sup>1)</sup> 50	•	High corrosion resistant steel HCR PC <sup>1)</sup> 70	-
High corrosion resistant steel HCR PC <sup>1)</sup> 80	(	Stainless steel R property class 50	~
Stainless steel R property class 80	*		

Alternatively: Colour coding according to DIN 976-1: 2016

<sup>1)</sup> PC = property class

**Installation conditions:**

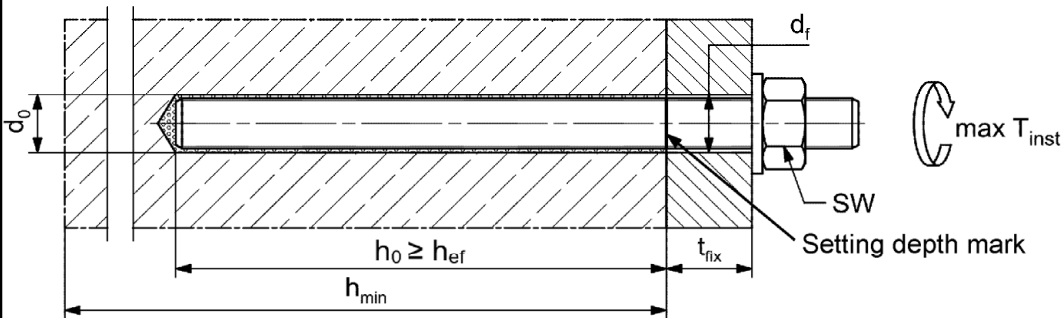

**Threaded rods, washers and hexagon nuts may also be used if the following requirements are fulfilled**

- Materials, dimensions and mechanical properties according to Annex A 5, Table A5.1
- Inspection certificate 3.1 according to EN 10204:2004, the documents shall be stored
- Setting depth is marked

Figures not to scale

fischer injection system FIS EB II

**Intended use**  
Installation parameters Anchor rods

**Annex B 3**

Appendix 10 / 34

**Table B4.1: Installation parameters for Rebars**

Nominal diameter of the rebar		$\phi$	8 <sup>1)</sup>		10 <sup>1)</sup>		12 <sup>1)</sup>		14	16	20	25	26	28	30	32	
Nominal drill hole diameter	$d_0$	[mm]	10	12	12	14	14	16	18	20	25	30	35	35	40	40	
Drill hole depth	$h_0$		$h_0 \geq h_{ef}$														
Effective embedment depth	$h_{ef,min}$		60	60	70	75	80	90	100	104	112	120	128				
	$h_{ef,max}$		160	200	240	280	320	400	500	520	560	600	640				
Simplified spacing and edge distance <sup>2)</sup>	$s = c$		40	45	55	60	65	85	120	120	140	140	160				
Minimum thickness of concrete member	$h_{min}$	$h_{ef} + 30$ ( $\geq 100$ )						$h_{ef} + 2d_0$									

1) Both drill hole diameters can be used

2) Detailed calculation according to Annex B 6 und B 7

**Rebar**

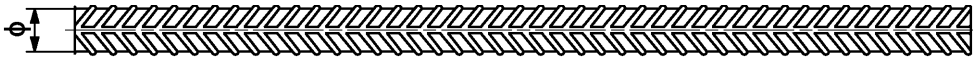

- The minimum value of related rib area  $f_{R,min}$  must fulfil the requirements of EN 1992-1-1:2004+AC:2010
- The rib height must be within the range:  $0,05 \cdot \phi \leq h_{rib} \leq 0,07 \cdot \phi$   
( $\phi$  = Nominal diameter of the rebar,  $h_{rib}$  = rib height)

**Installation conditions:**

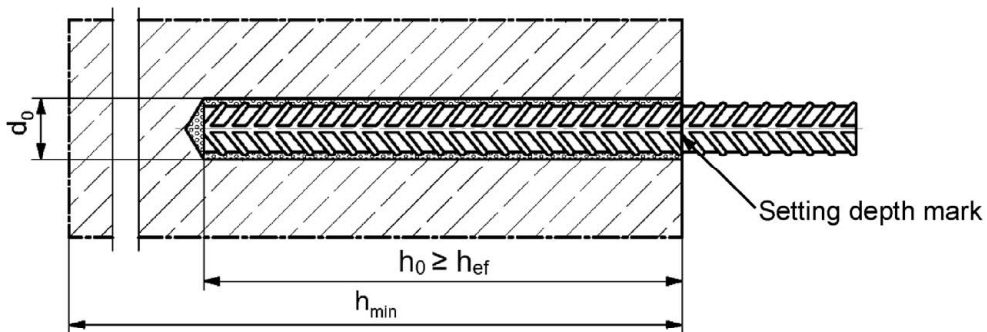

Figures not to scale

fischer injection system FIS EB II

**Intended use**  
Installation parameters Rebars

**Annex B 4**

Appendix 11 / 34

**Table B5.1: Installation parameters for fischer FRA**

fischer FRA		M12 <sup>1)</sup>		M16	M20	M24
Nominal diameter of the rebar	$\phi$	12		16	20	25
Nominal drill hole diameter	$d_0$	14	16	20	25	30
Drill hole depth	$h_0$	$h_{ef} + l_e$				
Effective embedment depth	$h_{ef,min}$	70	80	90	96	
	$h_{ef,max}$	140	220	300	380	
Distance concrete surface to welded joint	$l_e$	100				
Simplified spacing and edge distance <sup>2)</sup>	$s = c$	[mm]	55	65	85	105
Diameter of clearance hole in the fixture	pre-positioned anchorage $\leq d_f$		14	18	22	26
	push through anchorage $\leq d_f$		18	22	26	32
Minimum thickness of concrete member	$h_{min}$	$h_0 + 30$ ( $\geq 100$ )	$h_0 + 2d_0$			
Maximum torque moment for attachment of the fixture	$\max T_{inst}$	[Nm]	40	60	120	150

<sup>1)</sup> Both drill hole diameters can be used

<sup>2)</sup> Detailed calculation according to Annex B 6 and B 7

**fischer FRA**

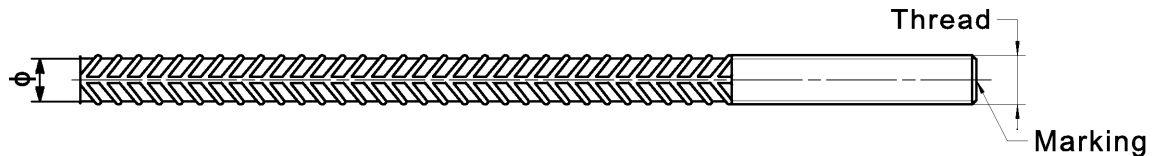

Marking frontal e. g:

- FRA (for stainless steel);
- FRA HCR (for high corrosion resistant steel)

**Installation conditions:**

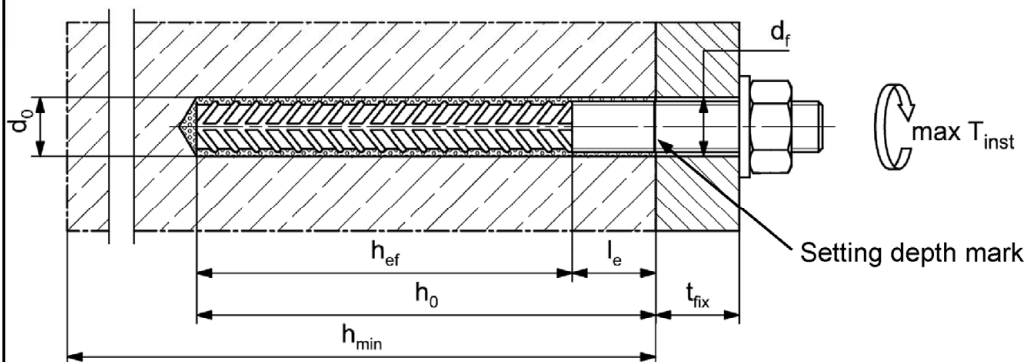

Figures not to scale

fischer injection system FIS EB II

**Intended use**  
Installation parameters fischer FRA

**Annex B 5**

Appendix 12 / 34

**Table B6.1: Minimum spacing and minimum edge distance for Anchor rods, Rebars and fischer FRA**

<b>Anchor rods</b>		<b>M8</b>	<b>M10</b>	<b>M12</b>	<b>-</b>	<b>M16</b>	<b>M20</b>	
<b>Rebars / fischer FRA (nominal diameter)</b>	$\phi$	<b>8</b>	<b>10</b>	<b>12</b>	<b>14</b>	<b>16</b>	<b>20</b>	
<b>Minimum edge distance</b>								
Uncracked / cracked concrete	$c_{min}$	[mm]	40	45	45	45	50	55
Spacing	s		according to Annex B 7					
<b>Minimum spacing</b>								
Uncracked / cracked concrete	$s_{min}$	[mm]	40	45	55	60	65	85
Edge distance	c		according to Annex B 7					
<b>Required projecting area</b>								
Uncracked concrete	$A_{sp,req}$	[1000 mm <sup>2</sup> ]	8,0	13,0	22,0	23,0	24,0	38,5
Cracked concrete			6,5	10,0	16,5	17,5	18,5	29,5

<b>Anchor rods</b>		<b>M24</b>	<b>-</b>	<b>-</b>	<b>M27</b>	<b>-</b>	<b>M30</b>	<b>-</b>	
<b>Rebars / fischer FRA (nominal diameter)</b>	$\phi$	<b>-</b>	<b>25</b>	<b>26</b>	<b>-</b>	<b>28</b>	<b>30</b>	<b>32</b>	
<b>Minimum edge distance</b>									
Uncracked / cracked concrete	$c_{min}$	[mm]	60	75	75	75	80	80	120
Spacing	s		according to Annex B 7						
<b>Minimum spacing</b>									
Uncracked / cracked concrete	$s_{min}$	[mm]	105	120	120	120	140	140	160
Edge distance	c		according to Annex B 7						
<b>Required projecting area</b>									
Uncracked concrete	$A_{sp,req}$	[1000 mm <sup>2</sup> ]	40,0	47,5	47,5	47,5	64,0	64,0	64,0
Cracked concrete			30,5	36,5	36,5	36,5	49,0	49,0	49,0

**Splitting failure** for minimum edge distance and spacing in dependence of the effective embedment depth  $h_{ef}$ .

For the calculation of minimum spacing and minimum edge distance of anchors in combination with different embedment depths and thicknesses of concrete members the following equation shall be fulfilled:

$$A_{sp,req} < A_{sp}$$

$A_{sp,req}$  = required projecting area

$A_{sp}$  = projecting area (according to Annex B 7)

fischer injection system FIS EB II

**Intended use**  
Minimum spacing and edge distance for Anchor rods, Rebars and fischer FRA

**Annex B 6**

Appendix 13 / 34

**Table B7.1: Projecting area  $A_{sp}$  with concrete member thickness**  
 $h > h_{ef} + 1,5 \cdot c$  and  $h \geq h_{min}$

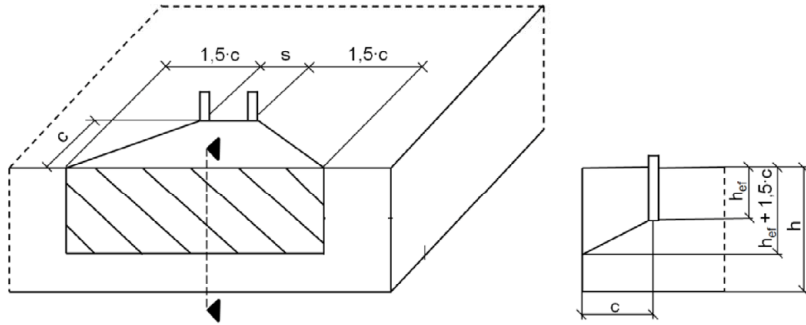

Single fastener	$A_{sp} = (3 \cdot c) \cdot (h_{ef} + 1,5 \cdot c)$	[mm <sup>2</sup> ]	with $c \geq c_{min}$
Group of fastener with $s > 3 \cdot c$	$A_{sp} = (6 \cdot c) \cdot (h_{ef} + 1,5 \cdot c)$	[mm <sup>2</sup> ]	
Group of fastener with $s \leq 3 \cdot c$	$A_{sp} = (3 \cdot c + s) \cdot (h_{ef} + 1,5 \cdot c)$	[mm <sup>2</sup> ]	

**Table B7.2: Projecting area  $A_{sp}$  with concrete member thickness**  
 $h \leq h_{ef} + 1,5 \cdot c$  and  $h \geq h_{min}$

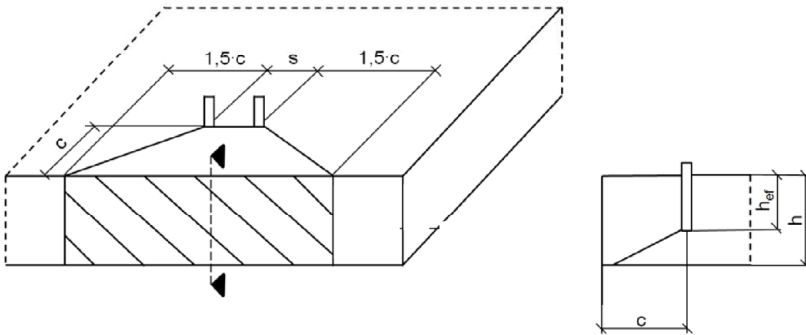

Single fastener	$A_{sp} = 3 \cdot c \cdot \text{existing } h$	[mm <sup>2</sup> ]	with $c \geq c_{min}$
Group of fastener with $s > 3 \cdot c$	$A_{sp} = 6 \cdot c \cdot \text{existing } h$	[mm <sup>2</sup> ]	
Group of fastener with $s \leq 3 \cdot c$	$A_{sp} = (3 \cdot c + s) \cdot \text{existing } h$	[mm <sup>2</sup> ]	

Edge distance and axial spacing shall be rounded up to at least 5 mm

Figures not to scale

fischer injection system FIS EB II

**Intended use**

Minimum thickness of concrete member for Anchor rods, Rebar, fischer FRA and minimum spacing and edge distance

**Annex B 7**

Appendix 14 / 34



**Table B8.1: Parameters of the cleaning brush BS (steel brush with steel bristles)**

The size of the cleaning brush refers to the drill hole diameter

Nominal drill hole diameter	$d_0$	[mm]	10	12	14	16	18	20	24	25	28	30	35	40
Steel brush diameter BS	$d_b$		11	14	16	20		25	26	27	30	40		42

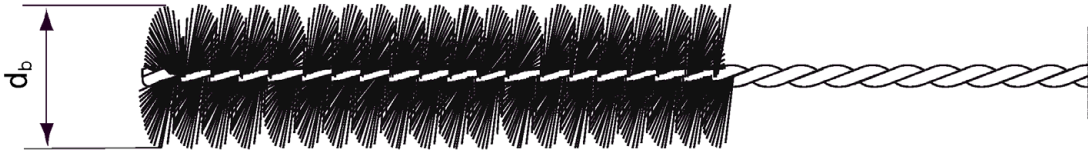

**Table B8.2: Conditions for use static mixer without an extension tube**

Nominal drill hole diameter	$d_0$	[mm]	10	12	14	16	18	20	24	25	28	30	35	40
Drill hole depth $h_0$ by using	FIS MR Plus		$\leq 90$	$\leq 120$	$\leq 140$	$\leq 150$	$\leq 160$	$\leq 190$	$\leq 210$					
	FIS UMR	-	-	$\leq 90$	$\leq 160$	$\leq 180$	$\leq 190$	$\leq 220$	$\leq 250$					

**Table B8.3 Maximum processing time of the mortar and minimum curing time**  
(During the curing time of the mortar the concrete temperature may not fall below the listed minimum temperature)

Temperature at anchoring base [°C]	Maximum processing time $t_{work}$	Minimum curing time $t_{cure}$
> 5 to 10	180 min	96 h
> 10 to 15	90 min	60 h
> 15 to 20	60 min	36 h
> 20 to 30	30 min	24 h
> 30 to 40	15 min	12 h

fischer injection system FIS EB II

**Intended use**  
Cleaning brush (steel brush)  
Processing time and curing time

**Annex B 8**



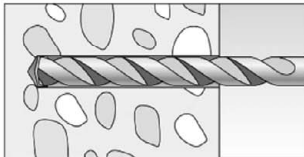
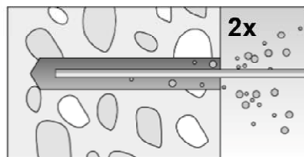
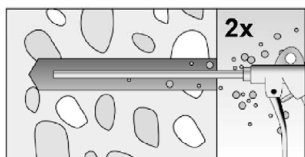
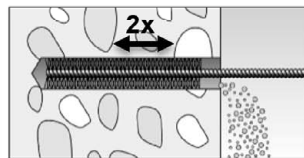
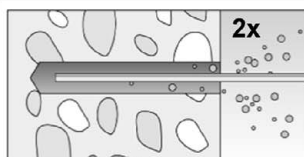
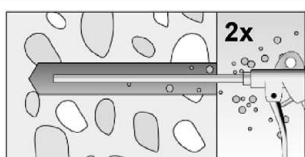

Appendix 15 / 34

# Installation instructions part 1

## Drilling and cleaning the hole (hammer drilling with standard drill bit)

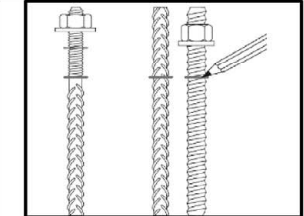
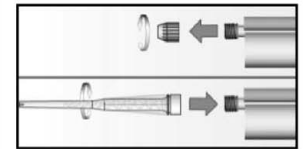
1		<p>Drill the hole. Nominal drill hole diameter <math>d_0</math> and drill hole depth <math>h_0</math> see <b>Tables B3.1, B4.1, B5.1.</b></p>	
2		<p>Clean the drill hole: For <math>h_{ef} \leq 12d</math> and <math>d_0 &lt; 18</math> mm blow out the hole twice by hand.</p>	 <p>For <math>h_{ef} &gt; 12d</math> and / or <math>d_0 \geq 18</math> mm blow out the hole twice with oil-free compressed air (<math>p \geq 6</math> bar).</p>
3		<p>Brush the drill hole twice. For drill hole diameter <math>d_0 \geq 18</math> mm and / or <math>h_{ef} &gt; 12d</math> use a power drill. For deep holes use an extension. Corresponding brushes see <b>Table B8.1.</b></p>	
4		<p>Clean the drill hole: For <math>h_{ef} \leq 12d</math> and <math>d_0 &lt; 18</math> mm blow out the hole twice by hand.</p>	 <p>For <math>h_{ef} &gt; 12d</math> and / or <math>d_0 \geq 18</math> mm blow out the hole twice with oil-free compressed air (<math>p \geq 6</math> bar).</p>

## Preparing

5		<p>Mark the setting depth of the steel element</p>	
6		<p>Remove the sealing cap Screw on the static mixer (the spiral in the static mixer must be clearly visible).</p>	
7			<p>Place the cartridge into the dispenser.</p>
8			<p>Extrude approximately 10 cm of material out until the resin is evenly grey in colour. Do not use mortar that is not uniformly grey.</p>

Go to Step 9

fischer injection system FIS EB II

**Intended use**  
Installation instructions part 1

**Annex B 9**



Appendix 16 / 34

## Installation instructions part 2

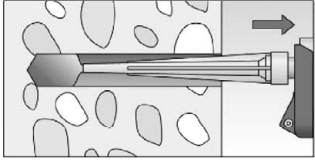
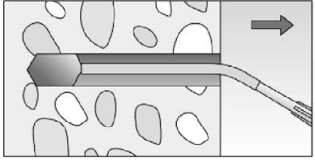
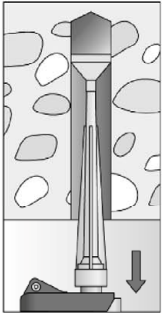
### Injection of the mortar

<p>9</p>	 <p>Fill approximately 2/3 of the drill hole with mortar. Always begin from the bottom of the hole and avoid bubbles.</p>	 <p>The conditions for mortar injection without extension tube can be found in <b>Table B8.2</b></p> <p>For deeper drill holes, than those mentioned in <b>Table B8.2</b>, use a suitable extension tube.</p>	 <p>For overhead installation, deep holes (<math>h_0 &gt; 250</math> mm) or drill hole diameter (<math>d_0 \geq 30</math> mm) use an injection-adaptor.</p>
----------	--	--	--

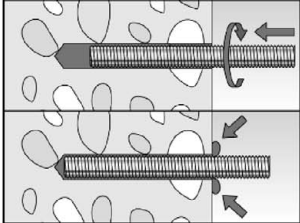
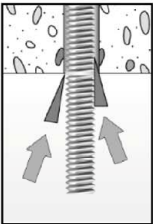
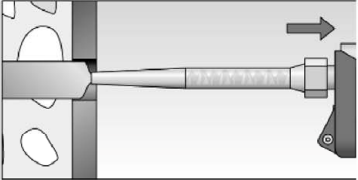
### Installation of Anchor rods

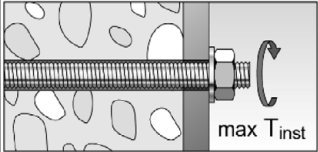
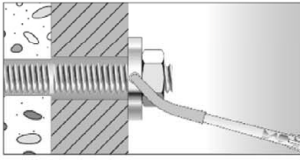
<p>10</p>		<p>Only use clean and oil-free anchor elements.</p> <p>Push the anchor rod with the setting depth mark down to the bottom of the hole, turning it slightly while doing so.</p> <p>After inserting the anchor element, excess mortar must be emerged around the anchor element.</p>
	 <p>For overhead installations support the anchor rod with wedges (e. g. fischer centering wedges) or fischer overhead clips.</p>	 <p>For push through installation fill the annular gap with mortar.</p>
<p>11</p>	 <p>Wait for the specified curing time <math>t_{cure}</math> see <b>Table B8.3</b>.</p>	<p>12</p>  <p>Mounting the fixture max <math>T_{inst}</math> see <b>Table B3.1</b>.</p>
<p>Option</p>		<p>After the minimum curing time is reached, the gap between anchor and fixture (annular clearance) may be filled with mortar via the fischer filling disc. Compressive strength <math>\geq 50</math> N/mm<sup>2</sup> (e.g. fischer injection mortars FIS EB II, FIS SB, FIS V Plus, FIS EM Plus).</p> <p>ATTENTION: Using fischer filling disk reduces <math>t_{fix}</math> (usable length of the anchor).</p>

fischer injection system FIS EB II



**Intended use**  
Installation instructions part 2

**Annex B 10**

Appendix 17 / 34

# Installation instructions part 3

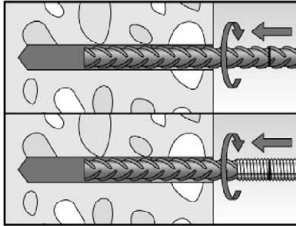
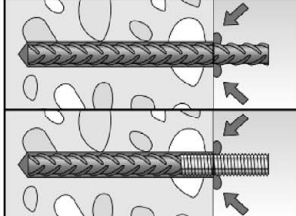
## Installation Rebars and fischer FRA

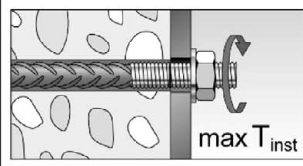
10		<p>Only use clean and oil-free rebars or fischer FRA. Push the rebar or the fischer FRA with the setting depth mark into the filled hole up to the setting depth mark.</p> <p>Recommendation: Rotation back and forth of the rebar or the fischer FRA makes pushing easy.</p>	
10		<p>When the setting depth mark is reached, excess mortar must be emerged from the mouth of the drill hole.</p>	
11	 <p>Wait for the specified curing time <math>t_{cure}</math> see <b>Table B8.3</b></p>	12	 <p>Mounting the fixture <math>max T_{inst}</math> see <b>Table B5.1</b></p>

fischer injection system FIS EB II

**Intended use**  
Installation instructions part 3

**Annex B 11**  
Appendix 18 / 34

**Table C1.1: Characteristic resistance to steel failure under tension and shear loading of Anchor rods and Threaded rods**

Anchor rod / Threaded rod		M8	M10	M12	M16	M20	M24	M27	M30			
<b>Characteristic resistance to steel failure under tension loading <sup>3)</sup></b>												
Characteristic resistance $N_{Rk,s}$	Steel zinc plated	Property class	[kN]	4.8	14,6 (13,2)	23,2 (21,4)	33,7	62,8	98,0	141,2	183,6	224,4
				5.8	18,3 (16,6)	29,0 (26,8)	42,1	78,5	122,5	176,5	229,5	280,5
				8.8	29,2 (26,5)	46,4 (42,8)	67,4	125,6	196,0	282,4	367,2	448,8
	Stainless steel R and high corrosion resistant steel HCR			50	18,3	29,0	42,1	78,5	122,5	176,5	229,5	280,5
				70	25,6	40,6	59,0	109,9	171,5	247,1	321,3	392,7
				80	29,2	46,4	67,4	125,6	196,0	282,4	367,2	448,8
<b>Partial factors <sup>1)</sup></b>												
Partial factor $\gamma_{Ms}$	Steel zinc plated	Property class	[-]	4.8	1,50							
				5.8	1,50							
				8.8	1,50							
	Stainless steel R and high corrosion resistant steel HCR			50	2,86							
				70	1,87 / fischer HCR: 1,50							
				80	1,60							
<b>Characteristic resistance to steel failure under shear loading <sup>3)</sup></b>												
<b>without lever arm</b>												
Characteristic resistance $V_{Rk,s}^0$	Steel zinc plated	Property class	[kN]	4.8	8,7 (7,9)	13,9 (12,8)	20,2	37,6	58,8	84,7	110,1	134,6
				5.8	10,9 (9,9)	17,4 (16,0)	25,2	47,1	73,5	105,9	137,7	168,3
				8.8	14,6 (13,2)	23,2 (21,4)	33,7	62,8	98,0	141,2	183,6	224,4
	Stainless steel R and high corrosion resistant steel HCR			50	9,1	14,5	21,0	39,2	61,2	88,2	114,7	140,2
				70	12,8	20,3	29,5	54,9	85,7	123,5	160,6	196,3
				80	14,6	23,2	33,7	62,8	98,0	141,2	183,6	224,4
Ductility factor	$k_7$	[-]	1,0									
<b>with lever arm</b>												
Characteristic resistance $M_{Rk,s}^0$	Steel zinc plated	Property class	[Nm]	4.8	14,9 (12,9)	29,9 (26,5)	52,3	132,9	259,6	448,8	665,7	899,5
				5.8	18,7 (16,1)	37,3 (33,2)	65,4	166,2	324,6	561,0	832,2	1124,4
				8.8	29,9 (25,9)	59,8 (53,1)	104,6	265,9	519,3	897,6	1331,5	1799,0
	Stainless steel R and high corrosion resistant steel HCR			50	18,7	37,3	65,4	166,2	324,6	561,0	832,2	1124,4
				70	26,2	52,3	91,5	232,6	454,4	785,4	1165	1574,1
				80	29,9	59,8	104,6	265,9	519,3	897,6	1331,5	1799,0
<b>Partial factors <sup>1)</sup></b>												
Partial factor $\gamma_{Ms}$	Steel zinc plated	Property class	[-]	4.8	1,25							
				5.8	1,25							
				8.8	1,25							
	Stainless steel R and high corrosion resistant steel HCR			50	2,38							
				70	1,56 / fischer HCR: 1,25 <sup>2)</sup>							
				80	1,33							
<sup>1)</sup> In absence of other national regulations. <sup>2)</sup> Only admissible for high corrosion resistant steel HCR, with $f_{yk}/f_{uk} \leq 0,8$ and $f_{uk} \leq 800$ N/mm <sup>2</sup> (e.g. anchor rods). <sup>3)</sup> Values in brackets are valid for undersized threaded rods with smaller stress area $A_s$ for hot dip galvanized threaded rods according to EN ISO 10684:2004+AC:2009.												

fischer injection system FIS EB II

**Performance**

Characteristic resistance to steel failure under tension and shear loading of Anchor rods and Threaded rods

**Annex C 1**

Appendix 19 / 34

**Table C2.1: Characteristic resistance to steel failure under tension and shear loading of Rebars**

Nominal diameter of the rebar	$\phi$	8	10	12	14	16	20	25	26	28	30	32
<b>Characteristic resistance to steel failure under tension loading</b>												
Characteristic resistance	$N_{Rk,s}$	[kN]	$A_s \cdot f_{uk}^{2)}$									
<b>Characteristic resistance to steel failure under shear loading</b>												
<b>Without lever arm</b>												
Characteristic resistance	$V^0_{Rk,s}$	[kN]	$k_6^{1)} \cdot A_s \cdot f_{uk}^{2)}$									
Ductility factor	$k_7$	[-]	1,0									
<b>With lever arm</b>												
Characteristic resistance	$M^0_{Rk,s}$	[Nm]	$1,2 \cdot W_{el} \cdot f_{uk}^{2)}$									

- 1) In accordance with EN 1992-4:2018 section 7.2.2.3.1  
 $k_6 = 0,6$  for fasteners made of carbon steel with  $f_{uk} \leq 500 \text{ N/mm}^2$   
 $= 0,5$  for fasteners made of carbon steel with  $500 < f_{uk} \leq 1000 \text{ N/mm}^2$   
 $= 0,5$  for fasteners made of stainless steel
- 2)  $f_{uk}$  respectively shall be taken from the specifications of the rebar.

**Table C2.2: Characteristic resistance to steel failure under tension and shear loading of fischer FRA**

fischer FRA		M12	M16	M20	M24	
<b>Characteristic resistance to steel failure under tension loading</b>						
Characteristic resistance	$N_{Rk,s}$	[kN]	62,1	110,5	172,7	263,0
<b>Partial factor<sup>1)</sup></b>						
Partial factor	$\gamma_{Ms}$	[-]	1,4			
<b>Characteristic resistance to steel failure under shear loading</b>						
<b>Without lever arm</b>						
Characteristic resistance	$V^0_{Rk,s}$	[kN]	33,7	62,8	98,0	141,2
Ductility factor	$k_7$	[-]	1,0			
<b>With lever arm</b>						
Characteristic resistance	$M^0_{Rk,s}$	[Nm]	104,8	266,3	519,2	898,0
<b>Partial factor<sup>1)</sup></b>						
Partial factor	$\gamma_{Ms}$	[-]	1,25			

1) In absence of other national regulations.

fischer injection system FIS EB II

**Performance**

Characteristic resistance to steel failure under tension and shear loading of Rebars and fischer FRA

**Annex C 2**

<b>Table C3.1: Characteristic resistance to concrete failure under tension and shear loading</b>														
<b>Size</b>			<b>All sizes</b>											
<b>Tension loading</b>														
Installation factor		$\gamma_{inst}$	[-]		See annex C 4 to C 6									
<b>Factors for the compressive strength of concrete &gt; C20/25</b>														
			Uncracked concrete					Cracked concrete						
Increasing factor $\psi_{fc}$ for cracked or uncracked concrete $\tau_{RK}(X,Y) = \psi_{fc} \cdot \tau_{RK}(C20/25)$	C25/30		[-]	1,05					1,02					
	C30/37			1,09					1,05					
	C35/45			1,12					1,06					
	C40/50			1,16					1,08					
	C45/55			1,19					1,09					
	C50/60			1,21					1,11					
<b>Splitting failure</b>														
Edge distance	$h / h_{ef} \geq 2,0$		$C_{cr,sp}$	[mm]	1,0 $h_{ef}$									
	$2,0 > h / h_{ef} > 1,3$				4,6 $h_{ef} - 1,8 h$									
	$h / h_{ef} \leq 1,3$				2,26 $h_{ef}$									
Spacing		$S_{cr,sp}$	2 $C_{cr,sp}$											
<b>Concrete cone failure</b>														
Uncracked concrete		$k_{ucr,N}$	[-]	11,0										
Cracked concrete		$k_{cr,N}$		7,7										
Edge distance		$C_{cr,N}$	[mm]	1,5 $h_{ef}$										
Spacing		$S_{cr,N}$		2 $C_{cr,N}$										
<b>Factors for sustained tension loading</b>														
Temperature range			[-]	24 °C / 43 °C			43 °C / 60 °C			50 °C / 72 °C				
Factor		$\psi_{sus}^0$	[-]	0,66			0,61			0,60				
<b>Shear loading</b>														
Installation factor		$\gamma_{inst}$	[-]		1,0									
<b>Concrete pry-out failure</b>														
Factor for pry-out failure		$k_8$	[-]		2,0									
<b>Concrete edge failure</b>														
Effective length of fastener for shear loading		$l_f$	[mm]	for $d_{nom} \leq 24$ mm: min ( $h_{ef}$ ; 12 $d_{nom}$ ) for $d_{nom} > 24$ mm: min ( $h_{ef}$ ; 8 $d_{nom}$ ; 300 mm)										
<b>Effective diameter of the fastener <math>d_{nom}</math></b>														
Size			M8	M10	M12	M16	M20	M24	M27	M30				
Anchor rods and Threaded rods		$d_{nom}$	[mm]	8	10	12	16	20	24	27	30			
fischer FRA		$d_{nom}$		- <sup>1)</sup>	- <sup>1)</sup>	12	16	20	25	- <sup>1)</sup>	- <sup>1)</sup>			
Size (nominal diameter of the rebar)		$\phi$		8	10	12	14	16	20	25	26	28	30	32
Rebar		$d_{nom}$	[mm]	8	10	12	14	16	20	25	26	28	30	32
1) Anchor type not part of the assessment														
fischer injection system FIS EB II										<b>Annex C 3</b> Appendix 21 / 34				
<b>Performance</b> Characteristic resistance to concrete failure under tension / shear loading														

**Table C4.1: Characteristic resistance to combined pull-out and concrete failure for Anchor rods and Threaded rods in hammer drilled holes; uncracked or cracked concrete**

Anchor rod / Threaded rod		M8	M10	M12	M16	M20	M24	M27	M30			
<b>Combined pullout and concrete cone failure</b>												
Calculation diameter	d	[mm]	8	10	12	16	20	24	27	30		
<b>Uncracked concrete</b>												
<b>Characteristic bond resistance in uncracked concrete C20/25</b>												
<u>Hammer-drilling with standard drill bit (dry or wet concrete)</u>												
Tem- perature range	I: 24 °C / 43 °C		$\tau_{RK,ucr}$	[N/mm <sup>2</sup> ]	14,0	14,0	14,0	14,0	14,0	13,0	12,0	12,0
	II: 43 °C / 60 °C				14,0	13,0	13,0	12,0	11,0	10,0	8,5	8,5
	III: 50 °C / 72 °C				9,0	9,0	9,0	9,0	9,0	8,5	8,0	7,5
<u>Hammer-drilling with standard drill bit (water filled hole)</u>												
Tem- perature range	I: 24 °C / 43 °C		$\tau_{RK,ucr}$	[N/mm <sup>2</sup> ]	14,0	14,0	14,0	14,0	14,0	12,0	12,0	12,0
	II: 43 °C / 60 °C				12,0	11,0	11,0	10,0	9,5	8,5	8,5	8,5
	III: 50 °C / 72 °C				9,0	9,0	9,0	8,5	8,0	7,5	7,0	6,5
<b>Installation factors</b>												
Dry or wet concrete		$\gamma_{inst}$	[-]	1,2								
Water filled hole				1,4								
<b>Cracked concrete</b>												
<b>Characteristic bond resistance in cracked concrete C20/25</b>												
<u>Hammer-drilling with standard drill bit (dry or wet concrete)</u>												
Tem- perature range	I: 24 °C / 43 °C		$\tau_{RK,cr}$	[N/mm <sup>2</sup> ]	7,0	7,0	7,0	6,5	6,0	6,0	5,5	5,5
	II: 43 °C / 60 °C				6,5	6,5	6,5	6,0	6,0	6,0	5,5	5,5
	III: 50 °C / 72 °C				6,0	6,0	6,0	5,5	5,5	5,5	5,0	5,0
<u>Hammer-drilling with standard drill bit (water filled hole)</u>												
Tem- perature range	I: 24 °C / 43 °C		$\tau_{RK,cr}$	[N/mm <sup>2</sup> ]	7,0	7,0	7,0	6,5	6,0	6,0	5,5	5,5
	II: 43 °C / 60 °C				5,5	5,5	5,5	5,0	4,5	4,5	4,0	4,0
	III: 50 °C / 72 °C				5,5	5,5	5,5	5,0	4,0	4,0	4,0	4,0
<b>Installation factors</b>												
Dry or wet concrete		$\gamma_{inst}$	[-]	1,2								
Water filled hole				1,4								

fischer injection system FIS EB II

**Performance**

Characteristic resistance to combined pull-out and concrete failure for Anchor rod and Threaded rods

**Annex C 4**

Appendix 22 / 34



**Table C5.1: Characteristic resistance to combined pull-out and concrete failure for Rebars in hammer drilled holes; uncracked or cracked concrete**

Rebars	$\phi$	8	10	12	14	16	20	25	26	28	30	32		
<b>Combined pullout and concrete cone failure</b>														
Calculation diameter	d	[mm]	8	10	12	14	16	20	25	26	28	30	32	
<b>Uncracked concrete</b>														
<b>Characteristic bond resistance in uncracked concrete C20/25</b>														
<u>Hammer-drilling with standard drill bit (dry or wet concrete)</u>														
Tem- perature range	I: 24 °C / 43 °C	$\tau_{RK,ucr}$	[N/mm <sup>2</sup> ]	14,0	14,0	14,0	13,0	13,0	12,0	11,0	11,0	11,0	11,0	
	II: 43 °C / 60 °C			14,0	13,0	13,0	12,0	11,0	10,0	10,0	9,0	8,5	8,0	8,0
	III: 50 °C / 72 °C			9,0	9,0	9,0	9,0	9,0	9,0	8,5	8,5	8,0	8,0	7,5
<u>Hammer-drilling with standard drill bit (water filled hole)</u>														
Tem- perature range	I: 24 °C / 43 °C	$\tau_{RK,ucr}$	[N/mm <sup>2</sup> ]	14,0	14,0	14,0	12,0	12,0	12,0	11,0	11,0	11,0	11,0	
	II: 43 °C / 60 °C			11,0	11,0	10,0	9,5	9,5	9,0	8,5	8,5	8,5	7,5	7,5
	III: 50 °C / 72 °C			9,0	9,0	9,0	8,5	8,0	7,5	7,0	6,5	6,5	6,0	6,0
<b>Installation factors</b>														
Dry or wet concrete	$\gamma_{inst}$	[-]	1,2											
Water filled hole			1,4											
<b>Cracked concrete</b>														
<b>Characteristic bond resistance in cracked concrete C20/25</b>														
<u>Hammer-drilling with standard drill bit (dry or wet concrete)</u>														
Tem- perature range	I: 24 °C / 43 °C	$\tau_{RK,cr}$	[N/mm <sup>2</sup> ]	7,0	7,0	7,0	6,5	6,5	6,0	6,0	5,5	5,5	5,5	
	II: 43 °C / 60 °C			6,5	6,5	6,5	6,0	6,0	6,0	5,5	5,5	5,5	5,0	5,0
	III: 50 °C / 72 °C			6,0	6,0	6,0	6,0	5,5	5,5	5,5	5,0	5,0	5,0	4,5
<u>Hammer-drilling with standard drill bit (water filled hole)</u>														
Tem- perature range	I: 24 °C / 43 °C	$\tau_{RK,cr}$	[N/mm <sup>2</sup> ]	7,0	7,0	7,0	7,0	6,5	6,0	6,0	5,5	5,5	5,5	
	II: 43 °C / 60 °C			5,5	5,5	5,5	5,0	5,0	4,5	4,0	4,0	4,0	4,0	3,5
	III: 50 °C / 72 °C			5,5	5,5	5,5	5,0	5,0	4,0	4,0	4,0	4,0	4,0	3,5
<b>Installation factors</b>														
Dry or wet concrete	$\gamma_{inst}$	[-]	1,2											
Water filled hole			1,4											
fischer injection system FIS EB II														
<b>Performance</b> Characteristic resistance to combined pull-out and concrete failure for Rebars														
<b>Annex C 5</b> Appendix 23 / 34														

**Table C6.1: Characteristic resistance for combined pull-out and concrete failure for fischer FRA in hammer drilled holes; uncracked or cracked concrete**

fischer FRA		M12	M16	M20	M24	
<b>Combined pullout and concrete cone failure</b>						
Calculation diameter	d [mm]	12	16	20	25	
<b>Uncracked concrete</b>						
<b>Characteristic bond resistance in uncracked concrete C20/25</b>						
<u>Hammer-drilling with standard drill bit (dry or wet concrete)</u>						
Tem- perature range	I: 24 °C / 43 °C	$\tau_{RK,ucr}$ [N/mm <sup>2</sup> ]	14,0	13,0	12,0	11,0
	II: 43 °C / 60 °C		13,0	11,0	10,0	10,0
	III: 50 °C / 72 °C		9,0	9,0	9,0	8,5
<u>Hammer-drilling with standard drill bit (water filled hole)</u>						
Tem- perature range	I: 24 °C / 43 °C	$\tau_{RK,ucr}$ [N/mm <sup>2</sup> ]	14,0	12,0	12,0	11,0
	II: 43 °C / 60 °C		10,0	9,5	9,0	8,5
	III: 50 °C / 72 °C		9,0	8,0	7,5	7,0
<b>Installation factors</b>						
Dry or wet concrete	$\gamma_{inst}$ [-]	[-]	1,2			
Water filled hole			1,4			
<b>Cracked concrete</b>						
<b>Characteristic bond resistance in cracked concrete C20/25</b>						
<u>Hammer-drilling with standard drill bit (dry or wet concrete)</u>						
Tem- perature range	I: 24 °C / 43 °C	$\tau_{RK,cr}$ [N/mm <sup>2</sup> ]	7,0	6,5	6,0	6,0
	II: 43 °C / 60 °C		6,5	6,0	6,0	5,5
	III: 50 °C / 72 °C		6,0	5,5	5,5	5,5
<u>Hammer-drilling with standard drill bit (water filled hole)</u>						
Tem- perature range	I: 24 °C / 43 °C	$\tau_{RK,cr}$ [N/mm <sup>2</sup> ]	7,0	6,5	6,0	6,0
	II: 43 °C / 60 °C		5,5	5,0	4,5	4,0
	III: 50 °C / 72 °C		5,5	5,0	4,0	4,0
<b>Installation factors</b>						
Dry or wet concrete	$\gamma_{inst}$ [-]	[-]	1,2			
Water filled hole			1,4			

fischer injection system FIS EB II

**Performance**

Characteristic resistance for combined pull-out and concrete failure for fischer FRA

**Annex C 6**

Appendix 24 / 34

<b>Table C7.1: Displacements for Anchor rods and Threaded rods</b>									
Anchor rod		M8	M10	M12	M16	M20	M24	M27	M30
<b>Displacement-Factors for tension loading<sup>1)</sup></b>									
<b>Uncracked or cracked concrete; Temperature range I, II, III</b>									
$\delta_{N0}$ -Factor	[mm/(N/mm <sup>2</sup> )]	0,08	0,08	0,09	0,10	0,11	0,12	0,12	0,13
$\delta_{N\infty}$ -Factor		0,11	0,12	0,13	0,15	0,16	0,17	0,18	0,19
<b>Displacement-Factors for shear loading<sup>2)</sup></b>									
<b>Uncracked or cracked concrete; Temperature range I, II, III</b>									
$\delta_{V0}$ -Factor	[mm/kN]	0,19	0,15	0,13	0,10	0,08	0,07	0,06	0,05
$\delta_{V\infty}$ -Factor		0,28	0,22	0,19	0,14	0,11	0,10	0,09	0,08
1) Calculation of effective displacement: $\delta_{N0} = \delta_{N0}\text{-Factor} \cdot \tau$ $\delta_{N\infty} = \delta_{N\infty}\text{-Factor} \cdot \tau$ $\tau =$ acting bond strength under tension loading					2) Calculation of effective displacement: $\delta_{V0} = \delta_{V0}\text{-Factor} \cdot V$ $\delta_{V\infty} = \delta_{V\infty}\text{-Factor} \cdot V$ $V =$ acting shear loading				

<b>Table C7.2: Displacements for Rebars and fischer FRA</b>											
Nominal diameter of the rebar $\phi$	8	10	12	14	16	20	25	26	28	30	32
fischer FRA	- <sup>1)</sup>	- <sup>1)</sup>	M12	- <sup>1)</sup>	M16	M20	M24	- <sup>1)</sup>	- <sup>1)</sup>	- <sup>1)</sup>	- <sup>1)</sup>
<b>Displacement-Factors for tension loading<sup>2)</sup></b>											
<b>Uncracked or cracked concrete; Temperature range I, II, III</b>											
$\delta_{N0}$ -Factor	[mm/(N/mm <sup>2</sup> )]	0,08	0,08	0,09	0,10	0,10	0,11	0,12	0,12	0,13	0,13
$\delta_{N\infty}$ -Factor		0,11	0,12	0,13	0,14	0,15	0,16	0,18	0,18	0,19	0,19
<b>Displacement-Factors for shear loading<sup>3)</sup></b>											
<b>Uncracked or cracked concrete; Temperature range I, II, III</b>											
$\delta_{V0}$ -Factor	[mm/kN]	0,19	0,15	0,13	0,11	0,10	0,08	0,06	0,06	0,06	0,05
$\delta_{V\infty}$ -Factor		0,28	0,22	0,19	0,16	0,14	0,11	0,09	0,09	0,08	0,08
1) Anchor type not part of the assessment						3) Calculation of effective displacement:					
2) Calculation of effective displacement: $\delta_{N0} = \delta_{N0}\text{-Factor} \cdot \tau$ $\delta_{N\infty} = \delta_{N\infty}\text{-Factor} \cdot \tau$ $\tau =$ acting bond strength under tension loading						$\delta_{V0} = \delta_{V0}\text{-Factor} \cdot V$ $\delta_{V\infty} = \delta_{V\infty}\text{-Factor} \cdot V$ $V =$ acting shear loading					

fischer injection system FIS EB II	<b>Annex C 7</b> Appendix 25 / 34
<b>Performance</b> Displacements for Anchor rods, Threaded rods, Rebars and fischer FRA	

**Table C8.1: Characteristics resistance to steel failure under tension / shear loading of Anchor rods and Threaded rods under seismic action performance category C1 or C2**

Anchor rod / Threaded rod			M12	M14	M16	M20	M22	M24	M27	M30		
<b>Characteristic resistance to steel failure under tension loading<sup>1)</sup></b>												
<b>Anchor rods and Threaded rods, performance category C1</b>												
Characteristic resistance $N_{Rk,s,C1}$	Steel zinc plated	Property class	4.8	[kN]	33,7	46,0	62,8	98,0	121,2	141,2	183,6	224,4
			5.8		42,1	57,5	78,5	122,5	151,5	176,5	229,5	280,5
	8.8		67,4		92,0	125,6	196,0	242,4	282,4	367,2	448,8	
	Stainless steel R and high corrosion resistant steel HCR		50		42,1	57,5	78,5	122,5	151,5	176,5	229,5	280,5
			70		59,0	80,5	109,9	171,5	212,1	247,1	321,3	392,7
			80		67,4	92,0	125,6	196,0	242,4	282,4	367,2	448,8
<b>Anchor rods and Threaded rods, performance category C2</b>												
Characteristic resistance $N_{Rk,s,C2}$	Steel zinc plated	Property class	4.8	[-]	30,3	-2)	56,5	88,2	-2)	141,2	-2)	-2)
			5.8		37,9	-2)	70,6	110,2	-2)	176,5	-2)	-2)
	8.8		60,6		-2)	113,0	176,4	-2)	282,4	-2)	-2)	
	Stainless steel R and high corrosion resistant steel HCR		50		37,9	-2)	70,6	110,2	-2)	176,5	-2)	-2)
			70		53,1	-2)	98,9	154,3	-2)	247,1	-2)	-2)
			80		60,6	-2)	113,0	176,4	-2)	282,4	-2)	-2)
<b>Characteristic resistance to steel failure under shear loading without lever arm<sup>1)</sup></b>												
<b>Anchor rods, performance category C1</b>												
Characteristic resistance $V_{Rk,s,C1}^0$	Steel zinc plated	Property class	4.8	[kN]	20,2	27,6	37,6	58,8	72,7	84,7	110,1	134,6
			5.8		25,2	34,5	47,1	73,5	90,9	105,9	137,7	168,3
	8.8		33,7		46,0	62,8	98,0	121,2	141,2	183,6	224,4	
	Stainless steel R and high corrosion resistant steel HCR		50		21,0	28,7	39,2	61,2	75,7	88,2	114,7	140,2
			70		29,5	40,2	54,9	85,7	106,0	123,5	160,6	196,3
			80		33,7	46,0	62,8	98,0	121,2	141,2	183,6	224,4
<b>Threaded rods, performance category C1</b>												
Characteristic resistance $V_{Rk,s,C1}^0$	Steel zinc plated	Property class	4.8	[kN]	14,1	19,3	26,3	41,1	50,9	59,3	77,1	94,2
			5.8		17,7	24,1	32,9	51,4	63,6	74,1	96,3	117,8
	8.8		23,6		32,2	43,9	68,6	84,8	98,8	128,5	157,0	
	Stainless steel R and high corrosion resistant steel HCR		50		14,7	20,1	27,4	42,8	53,0	61,7	80,3	98,1
			70		20,6	28,1	38,4	60,0	74,2	86,4	112,4	137,4
			80		23,6	32,2	43,9	68,6	84,8	98,8	128,5	157,0
<b>Anchor rods and Threaded rods, performance category C2</b>												
Characteristic resistance $V_{Rk,s,C2}^0$	Steel zinc plated	Property class	4.8	[-]	13,3	-2)	28,2	45,2	-2)	77,0	-2)	-2)
			5.8		16,6	-2)	35,3	56,5	-2)	96,3	-2)	-2)
	8.8		22,2		-2)	47,1	75,4	-2)	128,4	-2)	-2)	
	Stainless steel R and high corrosion resistant steel HCR		50		13,9	-2)	29,4	47,1	-2)	80,3	-2)	-2)
			70		19,4	-2)	41,2	66,0	-2)	112,4	-2)	-2)
			80		22,2	-2)	47,1	75,4	-2)	128,4	-2)	-2)

1) Partial factors for performance category C1 or C2 see **table C10.1**;  
for anchor rods the factor for steel ductility is 1,0

2) No performance assessed

fischer injection system FIS EB II

**Performance**

Characteristic resistance to steel failure for Anchor rods and Threaded rods under seismic action (performance category C1 / C2)

**Annex C 8**

Appendix 26 / 34

**Table C9.1: Characteristic resistance to steel failure under tension / shear loading of Rebars (B500B) under seismic action performance category C1 or C2**

Nominal diameter of the rebar	$\phi$	12	14	16	20	25	26	28	30	
<b>Characteristic resistance to steel failure under tension loading<sup>1)</sup></b>										
<b>Rebar B500B acc. to DIN 488-2:2009-08, performance category C1</b>										
Characteristic resistance	$N_{Rk,s,C1}$	[kN]	61,0	83,1	108,5	169,5	265,1	286,2	332,6	381,2
<b>Rebar B500B acc. to DIN 488-2:2009-08, performance category C2</b>										
Characteristic resistance	$N_{Rk,s,C2}$	[kN]	54,9	- <sup>2)</sup>	97,6	152,6	- <sup>2)</sup>	- <sup>2)</sup>	- <sup>2)</sup>	- <sup>2)</sup>
<b>Characteristic resistance to steel failure under shear loading, without lever arm<sup>1)</sup></b>										
<b>Rebar B500B acc. to DIN 488-2:2009-08, performance category C1</b>										
Characteristic resistance	$V^0_{Rk,s,C1}$	[kN]	21,3	29,1	37,9	59,3	92,7	100,1	116,4	133,4
<b>Rebar B500B acc. to DIN 488-2:2009-08, performance category C2</b>										
Characteristic resistance	$V^0_{Rk,s,C2}$	[kN]	20,1	- <sup>2)</sup>	40,7	65,2	- <sup>2)</sup>	- <sup>2)</sup>	- <sup>2)</sup>	- <sup>2)</sup>

1) Partial factors for performance category C1 or C2 see table C10.1

2) No performance assessed

**Table C9.2: Characteristic resistance to steel failure under tension / shear loading of fischer FRA under seismic action performance category C1 or C2**

fischer FRA		M12	M16	M20	M24	
<b>Characteristic resistance to steel failure under tension loading<sup>1)</sup></b>						
<b>fischer FRA, performance category C1</b>						
Characteristic resistance	$N_{Rk,s,C1}$	[kN]	62,1	110,5	172,7	263,0
<b>fischer FRA, performance category C2</b>						
Characteristic resistance	$N_{Rk,s,C2}$	[kN]	55,8	99,4	155,4	- <sup>2)</sup>
<b>Characteristic resistance to steel failure under shear loading, without lever arm<sup>1)</sup></b>						
<b>fischer FRA, performance category C1</b>						
Characteristic resistance	$V^0_{Rk,s,C1}$	[kN]	33,7	62,8	98,0	141,2
<b>fischer FRA, performance category C2</b>						
Characteristic resistance	$V^0_{Rk,s,C2}$	[kN]	22,2	47,1	75,4	- <sup>2)</sup>

1) Partial factors for performance category C1 or C2 see table C10.1

2) No performance assessed

fischer injection system FIS EB II	<b>Annex C 9</b> Appendix 27 / 34
<b>Performance</b> Characteristic resistance to steel failure under tension / shear loading of Rebars and fischer FRA under seismic action performance category C1 or C2	

**Table C10.1: Partial factors for Anchor rods, Threaded rods, Rebars (B500B) and fischer FRA under seismic action performance category C1 or C2**

Anchor rod / Threaded rod		M12	M16	M20	M24	M27	M30		
Nominal diameter of the rebar $\phi$		12	14	16	20	25	26	28	30
fischer FRA		M12	M16	M20	M24	_3)		_3)	
<b>Tension loading, steel failure<sup>1)</sup></b>									
Partial factor $\gamma_{Ms}$	Steel zinc plated	4.8	[-]	1,50					
		5.8		1,50					
	Property class	8.8		1,50					
		50		2,86					
		70		1,87 / fischer HCR: 1,50					
		80		1,60					
	Rebar	B500B		1,40					
	fischer	FRA		1,40					
<b>Shear loading, steel failure<sup>1)</sup></b>									
Partial factor $\gamma_{Ms}$	Steel zinc plated	4.8	[-]	1,25					
		5.8		1,25					
	Property class	8.8		1,25					
		50		2,38					
		70		1,56 / fischer HCR: 1,25 <sup>2)</sup>					
		80		1,33					
	Rebar	B500B		1,50					
	fischer	FRA		1,50					

1) In absence of other national regulations

2) Only admissible for high corrosion resistant steel HCR, with  $f_{yk}/f_{uk} \leq 0,8$  and  $f_{uk} \leq 800 \text{ N/mm}^2$  (e.g. anchor rods)

3) Anchor type not part of the assessment

fischer injection system FIS EB II

**Performance**

Partial factors for Anchor rods, Threaded rods, Rebars and fischer FRA under seismic action performance category C1 or C2

**Annex C 10**

Appendix 28 / 34

**Table C11.1: Characteristics resistance for combined pull-out and concrete failure for Anchor rods and Threaded rods in hammer drilled holes under seismic action performance category C1**

Anchor rod / Threaded rod		M12	M16	M20	M24	M27	M30	
<b>Characteristic bond resistance, combined pull-out and concrete cone failure</b>								
<b>Hammer-drilling with standard drill bit or hollow drill bit (dry or wet concrete)</b>								
Tem- perature range	I: 24 °C / 43 °C	$\tau_{RK,C1}$ [N/mm <sup>2</sup> ]	6,5	5,6	5,0	5,5	5,5	5,5
	II: 43 °C / 60 °C		6,5	5,6	5,0	5,5	5,5	5,5
	III: 50 °C / 72 °C		5,7	5,5	5,0	5,0	5,0	5,0
<b>Hammer-drilling with standard drill bit or hollow drill bit (water filled hole)</b>								
Tem- perature range	I: 24 °C / 43 °C	$\tau_{RK,C1}$ [N/mm <sup>2</sup> ]	6,5	5,0	4,7	4,7	4,7	4,7
	II: 43 °C / 60 °C		6,5	5,0	4,7	4,7	4,7	4,7
	III: 50 °C / 72 °C		5,7	5,5	5,0	5,0	5,0	5,0
<b>Installation factors</b>								
<b>Tension loading</b>								
Dry or wet concrete		$\gamma_{inst}$	[-]					1,2
Water filled hole								1,4

**Table C11.2: Characteristics resistance for combined pull-out and concrete failure for Rebars and fischer FRA in hammer drilled holes under seismic action performance category C1**

Nominal diameter of the rebar	$\phi$	12	14	16	20	25	26	28	30	
fischer FRA		M12	- <sup>1)</sup>	M16	M20	M24	- <sup>1)</sup>	- <sup>1)</sup>	- <sup>1)</sup>	
<b>Characteristic bond resistance, combined pull-out and concrete cone failure</b>										
<b>Hammer-drilling with standard drill bit or hollow drill bit (dry or wet concrete)</b>										
Tem- perature range	I: 24 °C / 43 °C	$\tau_{RK,C1}$ [N/mm <sup>2</sup> ]	6,5	6,0	6,0	6,0	5,5	5,5	5,5	5,5
	II: 43 °C / 60 °C		6,5	6,0	6,0	6,0	5,5	5,5	5,5	5,5
	III: 50 °C / 72 °C		5,7	5,5	5,5	5,0	5,0	5,0	5,0	5,0
<b>Hammer-drilling with standard drill bit or hollow drill bit (water filled hole)</b>										
Tem- perature range	I: 24 °C / 43 °C	$\tau_{RK,C1}$ [N/mm <sup>2</sup> ]	6,5	6,0	5,0	4,7	4,7	4,7	4,7	4,7
	II: 43 °C / 60 °C		6,5	6,0	5,0	4,7	4,7	4,7	4,7	4,7
	III: 50 °C / 72 °C		5,7	5,5	5,5	4,7	4,7	4,7	4,7	4,7
<b>Installation factors</b>										
<b>Tension loading</b>										
Dry or wet concrete		$\gamma_{inst}$	[-]					1,2		
Water filled hole								1,4		

<sup>1)</sup> Anchor type not part of the assessment

fischer injection system FIS EB II	<b>Annex C 11</b> Appendix 29 / 34
<b>Performance</b> Characteristics resistance under seismic action (performance category C1) for Anchor rods, Threaded rods, Rebars and fischer FRA	

**Table C12.1: Characteristics resistance for combined pull-out and concrete failure for Anchor rods and Threaded rods in hammer drilled holes under seismic action performance category C2**

Anchor rod / Threaded rod		M12	M16	M20	M24	
<b>Characteristic bond resistance, combined pull-out and concrete cone failure</b>						
<b>Hammer-drilling with standard drill bit or hollow drill bit (dry or wet concrete)</b>						
Tem- perature range	I: 24 °C / 43 °C	$\tau_{Rk,C2}$ [N/mm <sup>2</sup> ]	3,5	5,0	3,5	3,5
	II: 43 °C / 60 °C		3,5	5,0	3,5	3,5
	III: 50 °C / 72 °C		2,7	3,8	2,6	2,9
<b>Hammer-drilling with standard drill bit or hollow drill bit (water filled hole)</b>						
Tem- perature range	I: 24 °C / 43 °C	$\tau_{Rk,C2}$ [N/mm <sup>2</sup> ]	3,5	5,6	3,8	3,0
	II: 43 °C / 60 °C		3,5	5,2	3,6	3,0
	III: 50 °C / 72 °C		2,7	3,8	2,6	2,8
<b>Installation factors</b>						
<b>Tension loading</b>						
Dry or wet concrete		$\gamma_{inst}$ [-]	1,2			
Water filled hole			1,4			
<b>Displacement-Factors for tension loading<sup>1)</sup></b>						
$\delta_{N,(DLS)-Factor}$		[mm/(N/mm <sup>2</sup> )]	0,06	0,11	0,08	0,12
$\delta_{N,(ULS)-Factor}$			0,13	0,14	0,09	0,18
<b>Displacement-Factors for shear loading<sup>2)</sup></b>						
$\delta_{V,(DLS)-Factor}$		[mm/kN]	0,18	0,10	0,07	0,06
$\delta_{V,(ULS)-Factor}$			0,25	0,14	0,11	0,09

1) Calculation of effective displacement:

$$\delta_{N,C2(DLS)} = \delta_{N,(DLS)-Factor} \cdot \tau$$

$$\delta_{N,C2(ULS)} = \delta_{N,(ULS)-Factor} \cdot \tau$$

$\tau$  = acting bond strength under tension loading

2) Calculation of effective displacement:

$$\delta_{V,C2(DLS)} = \delta_{V,(DLS)-Factor} \cdot V$$

$$\delta_{V,C2(ULS)} = \delta_{V,(ULS)-Factor} \cdot V$$

$V$  = acting shear loading

fischer injection system FIS EB II

**Performance**

Characteristics resistance under seismic action (performance category C2) for Anchor rods, Threaded rods.

**Annex C 12**

Appendix 30 / 34



**Table C13.1: Characteristics resistance for combined pull-out and concrete failure for Rebars and fischer FRA in hammer drilled holes under seismic action performance category C2**

Nominal diameter of the rebar		$\phi$	12	16	20	
fischer FRA			M12	M16	M20	
<b>Characteristic bond resistance, combined pull-out and concrete cone failure</b>						
<b>Hammer-drilling with standard drill bit or hollow drill bit (dry or wet concrete)</b>						
Tem- perature range	I: 24 °C / 43 °C	$\tau_{Rk,C2}$	[N/mm <sup>2</sup> ]	3,5	5,0	3,5
	II: 43 °C / 60 °C			3,5	5,0	3,5
	III: 50 °C / 72 °C			2,7	3,8	2,6
<b>Hammer-drilling with standard drill bit or hollow drill bit (water filled hole)</b>						
Tem- perature range	I: 24 °C / 43 °C	$\tau_{Rk,C2}$	[N/mm <sup>2</sup> ]	3,5	5,6	3,8
	II: 43 °C / 60 °C			3,5	5,2	3,6
	III: 50 °C / 72 °C			2,7	3,8	2,6

<b>Installation factors</b>					
<b>Tension loading</b>					
Dry or wet concrete		$\gamma_{inst}$	[-]	1,2	
Water filled hole				1,4	

<b>Displacement-Factors for tension loading<sup>1)</sup></b>					
$\delta_{N,(DLS)-Factor}$		[mm/(N/mm <sup>2</sup> )]	0,06	0,11	0,08
$\delta_{N,(ULS)-Factor}$			0,13	0,14	0,09

<b>Displacement-Factors for shear loading<sup>2)</sup></b>					
$\delta_{V,(DLS)-Factor}$		[mm/kN]	0,18	0,10	0,07
$\delta_{V,(ULS)-Factor}$			0,25	0,14	0,11

1) Calculation of effective displacement:

$$\delta_{N,C2(DLS)} = \delta_{N,(DLS)-Factor} \cdot \tau$$

$$\delta_{N,C2(ULS)} = \delta_{N,(ULS)-Factor} \cdot \tau$$

$\tau$  = acting bond strength under tension loading

2) Calculation of effective displacement:

$$\delta_{V,C2(DLS)} = \delta_{V,(DLS)-Factor} \cdot V$$

$$\delta_{V,C2(ULS)} = \delta_{V,(ULS)-Factor} \cdot V$$

$V$  = acting shear loading

fischer injection system FIS EB II

**Performance**

Characteristics resistance under seismic action (performance category C2) for Rebar and fischer FRA.

**Annex C 13**

Appendix 31 / 34

**Table C14.1: Fire resistance to steel failure under tension and shear loading of Anchor rods and Threaded rods**

<b>Fire resistance to steel failure under tension and shear loading</b>						
<b>Anchor rod / Threaded rod</b>	<b>R30</b>			<b>R60</b>		
Steel zinc plated	$N_{Rk,s,fi,30}$ [kN]	$V_{Rk,s,fi,30}$ [kN]	$M^0_{Rk,s,fi,30}$ [Nm]	$N_{Rk,s,fi,60}$ [kN]	$V_{Rk,s,fi,60}$ [kN]	$M^0_{Rk,s,fi,60}$ [Nm]
M8	0,4	0,4	0,4	0,3	0,3	0,3
M10	0,9	0,9	1,1	0,8	0,8	1,0
M12	1,7	1,7	2,6	1,3	1,3	2,0
M16	3,1	3,1	6,7	2,4	2,4	5,0
M20	4,9	4,9	13,0	3,7	3,7	9,7
M24	7,1	7,1	22,5	5,3	5,3	16,8
M27	9,2	9,2	33,3	6,9	6,9	25,0
M30	11,2	11,2	45,0	8,4	8,4	33,7
<b>Anchor rod / Threaded rod</b>	<b>R90</b>			<b>R120</b>		
Steel zinc plated	$N_{Rk,s,fi,90}$ [kN]	$V_{Rk,s,fi,90}$ [kN]	$M^0_{Rk,s,fi,90}$ [Nm]	$N_{Rk,s,fi,120}$ [kN]	$V_{Rk,s,fi,120}$ [kN]	$M^0_{Rk,s,fi,120}$ [Nm]
M8	0,3	0,3	0,3	0,2	0,2	0,2
M10	0,6	0,6	0,7	0,5	0,5	0,6
M12	1,1	1,1	1,7	0,8	0,8	1,3
M16	2,0	2,0	4,3	1,6	1,6	3,3
M20	3,2	3,2	8,4	2,5	2,5	6,5
M24	4,6	4,6	14,6	3,5	3,5	11,2
M27	6,0	6,0	21,6	4,6	4,6	16,6
M30	7,3	7,3	29,2	5,6	5,6	22,5
<b>Anchor rod / Threaded rod</b>	<b>R30</b>			<b>R60</b>		
Stainless steel R and high corrosion resistant steel HCR	$N_{Rk,s,fi,30}$ [kN]	$V_{Rk,s,fi,30}$ [kN]	$M^0_{Rk,s,fi,30}$ [Nm]	$N_{Rk,s,fi,60}$ [kN]	$V_{Rk,s,fi,60}$ [kN]	$M^0_{Rk,s,fi,60}$ [Nm]
M8	0,7	0,7	0,7	0,6	0,6	0,6
M10	1,5	1,5	1,9	1,2	1,2	1,5
M12	2,5	2,5	3,9	2,1	2,1	3,3
M16	4,7	4,7	10,0	3,9	3,9	8,3
M20	7,4	7,4	19,5	6,1	6,1	16,2
M24	10,6	10,6	33,7	8,8	8,8	28,1
M27	13,8	13,8	49,9	11,5	11,5	41,6
M30	16,8	16,8	67,5	14,0	14,0	56,2
<b>Anchor rod / Threaded rod</b>	<b>R90</b>			<b>R120</b>		
Stainless steel R and high corrosion resistant steel HCR	$N_{Rk,s,fi,90}$ [kN]	$V_{Rk,s,fi,90}$ [kN]	$M^0_{Rk,s,fi,90}$ [Nm]	$N_{Rk,s,fi,120}$ [kN]	$V_{Rk,s,fi,120}$ [kN]	$M^0_{Rk,s,fi,120}$ [Nm]
M8	0,4	0,4	0,4	0,4	0,4	0,4
M10	0,9	0,9	1,2	0,8	0,8	1,0
M12	1,7	1,7	2,6	1,3	1,3	2,1
M16	3,1	3,1	6,7	2,5	2,5	5,3
M20	4,9	4,9	13,0	3,9	3,9	10,4
M24	7,1	7,1	22,5	5,6	5,6	18,0
M27	9,2	9,2	33,3	7,3	7,3	26,6
M30	11,2	11,2	45,0	9,0	9,0	36,0

fischer injection system FIS EB II	<b>Annex C 14</b> Appendix 32 / 34
<b>Performance</b> Fire resistance to steel failure under tension and shear loading of Anchor rods and Threaded rods	

**Table C15.1: Fire resistance to steel failure under tension and shear loading of Rebars and fischer FRA**

<b>Fire resistance to steel failure under tension and shear loading</b>						
<b>Rebar</b>	<b>R30</b>			<b>R60</b>		
Bars and de-coiled rods	$N_{Rk,s,fi,30}$ [kN]	$V_{Rk,s,fi,30}$ [kN]	$M^0_{Rk,s,fi,30}$ [Nm]	$N_{Rk,s,fi,60}$ [kN]	$V_{Rk,s,fi,60}$ [kN]	$M^0_{Rk,s,fi,60}$ [Nm]
φ 8	0,5	0,5	0,6	0,5	0,5	0,5
φ 10	1,2	1,2	1,8	1,0	1,0	1,5
φ 12	2,3	2,3	4,1	1,7	1,7	3,0
φ 14	3,1	3,1	6,5	2,3	2,3	4,9
φ 16	4,0	4,0	9,6	3,0	3,0	7,2
φ 20	6,3	6,3	18,8	4,7	4,7	14,1
φ 25	9,8	9,8	36,8	7,4	7,4	27,6
φ 26	10,6	10,6	41,4	8,0	8,0	31,1
φ 28	12,3	12,3	51,8	9,2	9,2	38,8
φ 30	14,1	14,1	63,6	10,6	10,6	47,7
φ 32	16,1	16,1	77,2	12,1	12,1	57,9
<b>Rebar</b>	<b>R90</b>			<b>R120</b>		
Bars and de-coiled rods	$N_{Rk,s,fi,90}$ [kN]	$V_{Rk,s,fi,90}$ [kN]	$M^0_{Rk,s,fi,90}$ [Nm]	$N_{Rk,s,fi,120}$ [kN]	$V_{Rk,s,fi,120}$ [kN]	$M^0_{Rk,s,fi,120}$ [Nm]
φ 8	0,4	0,4	0,4	0,3	0,3	0,3
φ 10	0,8	0,8	1,2	0,6	0,6	0,9
φ 12	1,5	1,5	2,6	1,1	1,1	2,0
φ 14	2,0	2,0	4,2	1,5	1,5	3,2
φ 16	2,6	2,6	6,3	2,0	2,0	4,8
φ 20	4,1	4,1	12,2	3,1	3,1	9,4
φ 25	6,4	6,4	23,9	4,9	4,9	18,4
φ 26	6,9	6,9	26,9	5,3	5,3	20,7
φ 28	8,0	8,0	33,6	6,2	6,2	25,9
φ 30	9,2	9,2	41,4	7,1	7,1	31,8
φ 32	10,5	10,5	50,2	8,0	8,0	38,6
<b>fischer FRA</b>	<b>R30</b>			<b>R60</b>		
Stainless steel R and high corrosion resistant steel HCR	$N_{Rk,s,fi,30}$ [kN]	$V_{Rk,s,fi,30}$ [kN]	$M^0_{Rk,s,fi,30}$ [Nm]	$N_{Rk,s,fi,60}$ [kN]	$V_{Rk,s,fi,60}$ [kN]	$M^0_{Rk,s,fi,60}$ [Nm]
M12	2,5	2,5	3,9	2,1	2,1	3,3
M16	4,7	4,7	10,0	3,9	3,9	8,3
M20	7,4	7,4	19,5	6,1	6,1	16,2
M24	10,6	10,6	33,7	8,8	8,8	28,1
<b>fischer FRA</b>	<b>R90</b>			<b>R120</b>		
Stainless steel R and high corrosion resistant steel HCR	$N_{Rk,s,fi,90}$ [kN]	$V_{Rk,s,fi,90}$ [kN]	$M^0_{Rk,s,fi,90}$ [Nm]	$N_{Rk,s,fi,120}$ [kN]	$V_{Rk,s,fi,120}$ [kN]	$M^0_{Rk,s,fi,120}$ [Nm]
M12	1,7	1,7	2,6	1,3	1,3	2,1
M16	3,1	3,1	6,7	2,5	2,5	5,3
M20	4,9	4,9	13,0	3,9	3,9	10,4
M24	7,1	7,1	22,5	5,6	5,6	18,0

fischer injection system FIS EB II	<b>Annex C 15</b> Appendix 33 / 34
<b>Performance</b> Fire resistance to steel failure under tension and shear loading of Rebars an fischer FRA	

# Characteristic bond resistance for cracked concrete under fire conditions for Anchor rods, Threaded rods, Rebars and fischer FRA for hammer drilled holes

The characteristic bond resistance for cracked concrete under fire conditions for a given temperature

$\tau_{RK,fi}(\theta)$  has to be calculated by the following equation:

$$\tau_{RK,fi}(\theta) = k_{fi,p}(\theta) \cdot \tau_{RK,cr,C20/25}$$

$\theta$	=	Temperature in °C in the mortar layer		
$\tau_{RK,fi}(\theta)$	=	Characteristic bond resistance for cracked and uncracked concrete under fire exposure for a given temperature in N/mm <sup>2</sup> for concrete classes C20/25 to C50/60		
$k_{fi,p}(\theta)$	=	Reduction factor under fire conditions		
$\tau_{RK,cr,C20/25}$	=	Characteristic bond resistance for cracked concrete C20/25 in N/mm <sup>2</sup> , given in Table C4.1, Table C5.1 or Table C6.1, respectively		
Anchor rods and Threaded rods	If: $\theta > 20\text{ °C}$ If: $\theta > \theta_{max} = 373\text{ °C}$	$k_{fi,p}(\theta) = 61,573 \cdot \theta^{-1,400} \geq 1,0$ $k_{fi,p}(\theta) = 0$		see Figure C16.1
Rebars and fischer FRA	If: $\theta > 23\text{ °C}$ If: $\theta > \theta_{max} = 236\text{ °C}$	$k_{fi,p}(\theta) = 252,678 \cdot \theta^{-1,777} \geq 1,0$ $k_{fi,p}(\theta) = 0$		see Figure C16.2

**Figure C16.1:** Graph of reduction factor  $k_{fi,p}(\theta)$  for anchor rods threaded rods

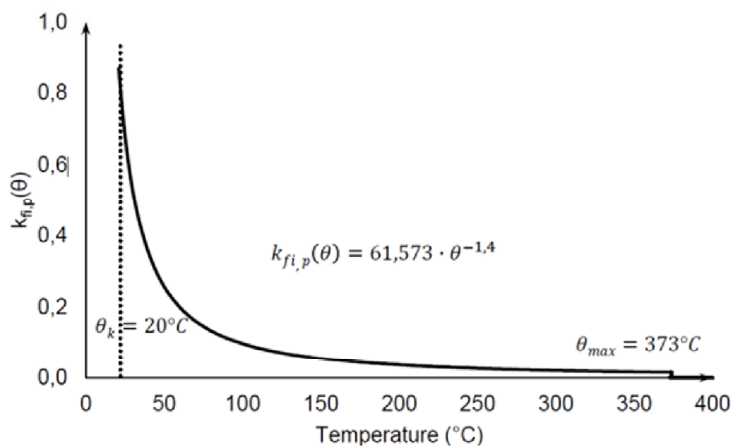

**Figure C16.2:** Graph of reduction factor  $k_{fi,p}(\theta)$  for rebars and fischer FRA

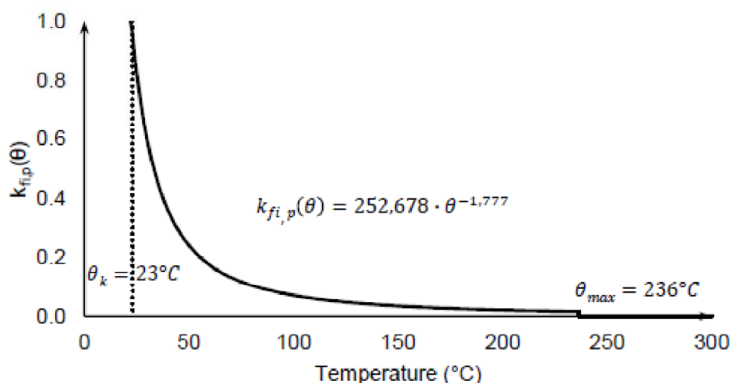

fischer injection system FIS EB II

**Performance**  
Characteristic bond resistance under fire conditions

**Annex C 16**

Appendix 34 / 34